



LTC3453

Synchronous Buck-Boost High Power White LED Driver

FEATURES

- High Efficiency: 90% Typical Over Entire Li-Ion Battery Range
- Wide V_{IN} Range: 2.7V to 5.5V
- Up to 500mA Continuous Output Current
- Internal Soft-Start
- Open/Shorted LED Protection
- LED Current Matching Typically <2%
- Constant Frequency 1MHz Operation
- Low Shutdown Current: 6 μ A
- Overtemperature Protection
- Small Thermally Enhanced 16-Lead (4mm x 4mm) QFN Package

APPLICATIONS

- Cell Phones
- Digital Cameras
- PDAs
- Portable Devices

LT, LTC and LT are registered trademarks of Linear Technology Corporation. Any other names or titles mentioned may be trademarks or registered trademarks of their respective companies.

DESCRIPTION

The LTC[®]3453 is a synchronous buck-boost DC/DC converter optimized for driving up to 4 white LEDs at a combined current of up to 500mA from a single Li-Ion battery input. The regulator operates in either synchronous buck, synchronous boost, or buck-boost mode, depending on input voltage and LED maximum forward voltage. Optimum efficiency is achieved using a proprietary architecture that determines which LED requires the largest forward voltage drop at its programmed current, and regulates the common output rail for lowest dropout. Efficiency of 90% can be achieved over the entire usable range of a Li-Ion battery (2.7V to 4.2V).

LED current is programmable to one of four levels (including shutdown) with dual current setting resistors and dual enable pins. In shutdown, the supply current is only 6 μ A.

A high constant operating frequency of 1MHz allows the use of a small external inductor. The LTC3453 is offered in a low profile (0.75mm) thermally enhanced 16-lead (4mm x 4mm) QFN package.

TYPICAL APPLICATION

High Efficiency Torch/Flash LED Driver

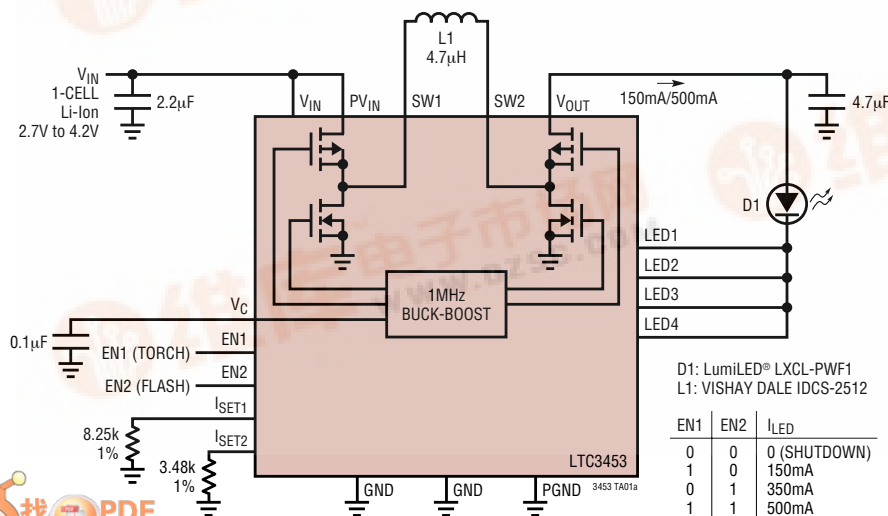

D1: LumiLED[®] LXCL-PWF1
L1: VISHAY DALE IDCS-2512

EN1	EN2	I_{LED}
0	0	0 (SHUTDOWN)
1	0	150mA
0	1	350mA
1	1	500mA

Torch Mode Efficiency vs V_{IN}

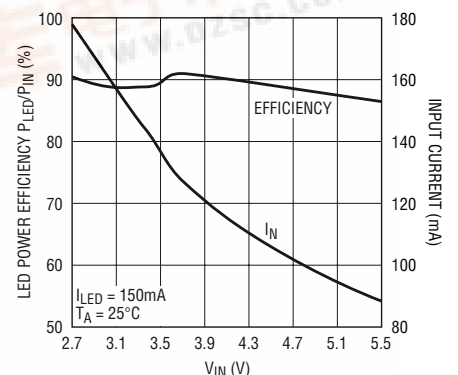

3453 TA01b



LTC3453

ABSOLUTE MAXIMUM RATINGS

(Note 1)

V_{IN} , PV_{IN} , SW1, SW2, V_{OUT} Voltage -0.3V to 6V
LED1 to LED4 Voltage -0.3V to ($V_{OUT} + 0.3V$) or 6V
 V_C , EN1, EN2,

I_{SET1} , I_{SET2} Voltage -0.3V to ($V_{IN} + 0.3V$) or 6V
LED1 to LED4 Peak Current 250mA
Storage Temperature Range -65°C to 125°C
Operating Temperature Range (Note 2) ... -40°C to 85°C
Junction Temperature (Note 3) 125°C

PACKAGE/ORDER INFORMATION

<p>TOP VIEW</p> <p>UF PACKAGE 16-LEAD (4mm x 4mm) PLASTIC QFN EXPOSED PAD (PIN 17) IS PGND MUST BE SOLDERED TO PCB $T_{JMAX} = 110^{\circ}C$, $\theta_{JA} = 40^{\circ}C/W$, $\theta_{JC} = 2.6^{\circ}C/W$</p>	<p>ORDER PART NUMBER</p> <p>LTC3453EUF</p> <p>UF PART MARKING</p> <p>3453</p>
--	---

Consult LTC Marketing for parts specified with wider operating temperature ranges.

ELECTRICAL CHARACTERISTICS

The ● denotes the specifications which apply over the full operating temperature range, otherwise specifications are at $T_A = 25^{\circ}C$, $V_{IN} = V_{OUT} = 3.6V$ unless otherwise noted. (Note 2)

PARAMETER	CONDITIONS	MIN	TYP	MAX	UNITS
Input Supply Voltage		● 2.7		5.5	V
Input DC Supply Current					
Normal Operation	$2.7V \leq V_{IN} \leq 5.5V$, $R_{ISET1} R_{ISET2} = 51.1k$, $I_{LEDx} = 0$ (Note 4)		0.6	1	mA
Shutdown	$2.7V \leq V_{IN} \leq 5.5V$; $V_{EN1} = V_{EN2} = 0V$		6	18	μA
UVLO	$V_{IN} < UVLO$ Threshold		3	5	μA
Undervoltage Lockout Threshold	V_{IN} Rising V_{IN} Falling	● 1.6	2 1.9	2.3	V V
$V_{EN1,2}$ DC Threshold for Normal Operation	$2.7V \leq V_{IN} \leq 5.5V$, $V_{EN1,2}$ Rising	●	0.65	1	V
$V_{EN1,2}$ DC Threshold for Shutdown ($I_{LEDx} = 0$)	$2.7V \leq V_{IN} \leq 5.5V$, $V_{EN1,2}$ Falling	●	0.2	0.63	V
$V_{EN1,2}$ Input Current		● -1		1	μA
$I_{SET1,2}$ Servo Voltage	$R_{ISET1,2} = 4.12k$, $0^{\circ}C \leq T_A \leq 85^{\circ}C$ $R_{ISET1,2} = 4.12k$, $-40^{\circ}C \leq T_A \leq 85^{\circ}C$	788 ● 780	800 800	812 812	mV mV
LED Output Current Ratio	$I_{LED}/(I_{SET1} + I_{SET2})$, $I_{LEDx} = 75mA$, $V_{LEDx} = 300mV$, $2.7V \leq V_{IN} \leq 5.5V$	● 365 357	384 384	403 403	mA/mA mA/mA
LED Output Current Matching	$(MAX - MIN)/[(MAX + MIN)/2] \cdot 100\%$, $I_{LEDx} = 75mA$ $V_{LEDx} = 300mV$		2	6	%
LED Pin Drain Voltage	$V_{IN} = 3.6V$, $I_{LEDx} = 75mA$		130		mV
Regulated Maximum V_{OUT}	$V_{LEDx} = 0V$	● 4.4	4.5	4.6	V
PMOS Switch R_{ON}	Switches A and D, @ 100mA		0.3		Ω
NMOS Switch R_{ON}	Switches B and C, @ 100mA		0.25		Ω
Forward Current Limit	Switch A	1125	1612	2100	mA
Reverse Current Limit	Switch D		200		mA
PMOS Switch Leakage	Switches A and D	●		1	μA
NMOS Switch Leakage	Switches B and C	●		1	μA
Oscillator Frequency		0.9	1	1.1	MHz
Soft-Start Time			0.65		ms

ELECTRICAL CHARACTERISTICS

Note 1: Absolute Maximum Ratings are those values beyond which the life of a device may be impaired.

Note 2: The LTC3453E is guaranteed to meet specifications from 0°C to 70°C. Specifications over the -40°C to 85°C operating temperature range are assured by design, characterization and correlation with statistical process controls.

Note 3: T_J is calculated from the ambient temperature T_A and power dissipation P_D according to the following formula:

$$T_J = T_A + (P_D \cdot \theta_{JA} \text{ } ^\circ\text{C/W}).$$

Note 4: Dynamic supply current is higher due to the gate charge being delivered at the switching frequency.

TYPICAL PERFORMANCE CHARACTERISTICS

Input DC Supply Current in Shutdown vs Temperature

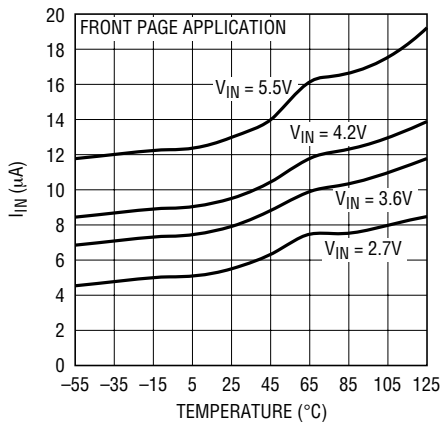

Undervoltage Lockout Threshold vs Temperature

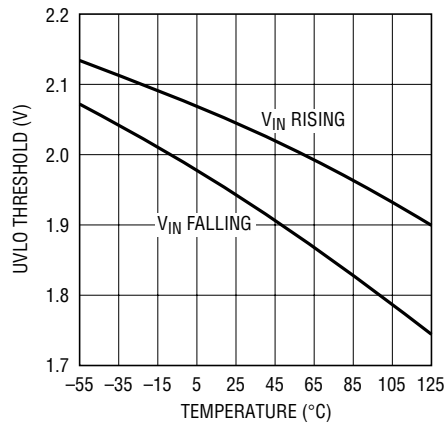

I_{SET1,2} Servo Voltage vs Temperature

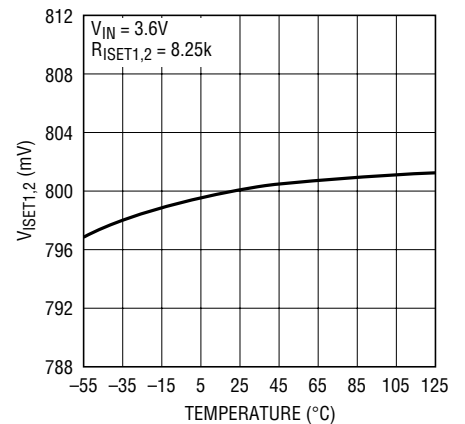

I_{SET1,2} Servo Voltage vs V_{IN}

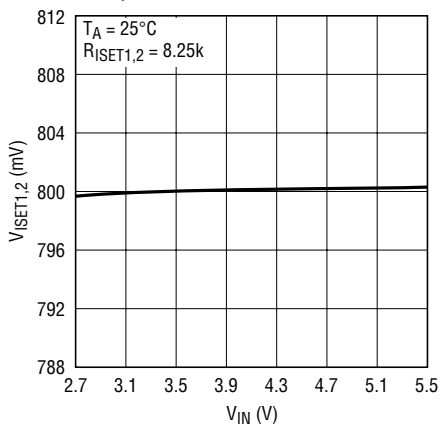

Regulated Maximum V_{OUT} vs Temperature

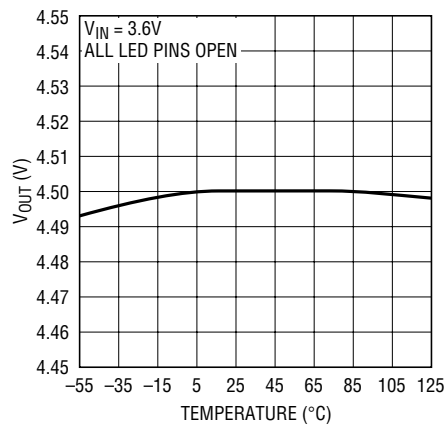

Oscillator Frequency vs Temperature

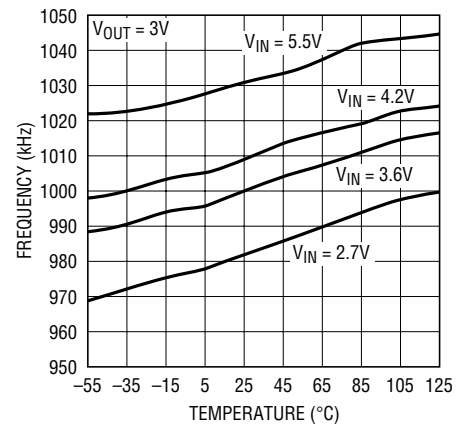

TYPICAL PERFORMANCE CHARACTERISTICS

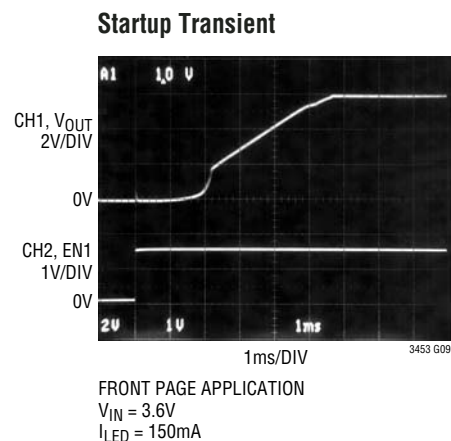
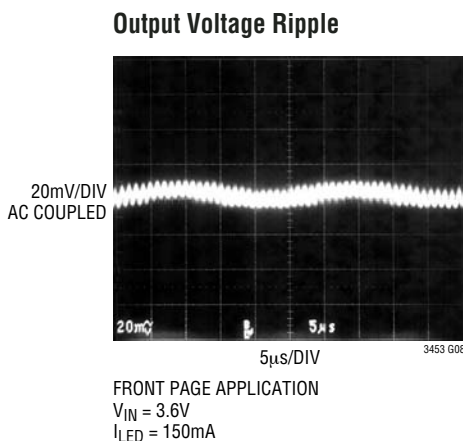
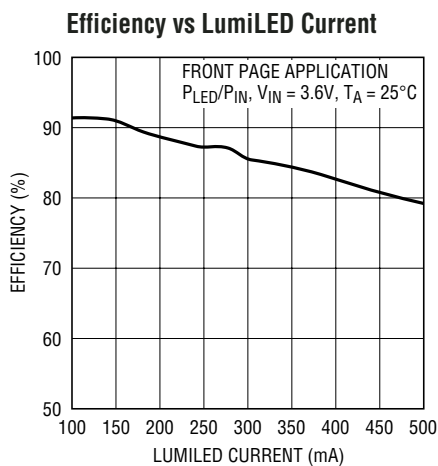

PIN FUNCTIONS

V_{IN} (Pin 1): Signal Voltage Input Supply Pin [$2.7V \leq V_{IN} \leq 5.5V$]. Recommended bypass capacitor to GND is 2.2µF ceramic or larger. Connect to PV_{IN} (Pin 16).

EN1 (Pin 2): Enable Input Pin for I_{SET1} Current.

I_{SET1} (Pin 3): White Led Current Programming Pin. A resistor to ground programs each current source output to $I_{LED} = 384(0.8V/R_{ISET1})$. This amount of current adds to any amount set by EN2/I_{SET2} if also used.

LED1 to LED4 (Pins 4, 6, 7, 9): Individual Low Dropout Current Source Outputs for White LED Current Biasing. Connect each white LED between V_{OUT} and an individual LED_x pin. Unused LED_x outputs should be connected to V_{OUT}.

GND (Pins 5 and 8): Signal Ground Pin. Connect to PGND (Exposed Pad).

I_{SET2} (Pin 10): White Led Current Programming Pin. A resistor to ground programs each current source output to $I_{LED} = 384(0.8V/R_{ISET2})$. This amount of current adds to any amount set by EN1/I_{SET1} if also used.

EN2 (Pin 11): Enable Input Pin for I_{SET2} Current.

V_C (Pin 12): Compensation Point for the Internal Error Amplifier Output. Recommended compensation capacitor to GND is 0.1µF ceramic or larger.

V_{OUT} (Pin 13): Buck-Boost Output Pin. Recommended bypass capacitor to GND is 4.7µF ceramic.

SW2 (Pin 14): Switching Node Pin. Connected to internal power switches C and D. External inductor connects between SW1 and SW2. Recommended value is 4.7µH.

SW1 (Pin 15): Switching Node Pin. Connected to internal power switches A and B. External inductor connects between SW1 and SW2. Recommended value is 4.7µH.

PV_{IN} (Pin 16): Power Voltage Input Supply Pin. Connect to V_{IN} (Pin 1).

Exposed Pad (Pin 17): Power Ground Pin. Connect to GND (Pin 8) and solder to PCB ground for optimum thermal performance.

BLOCK DIAGRAM

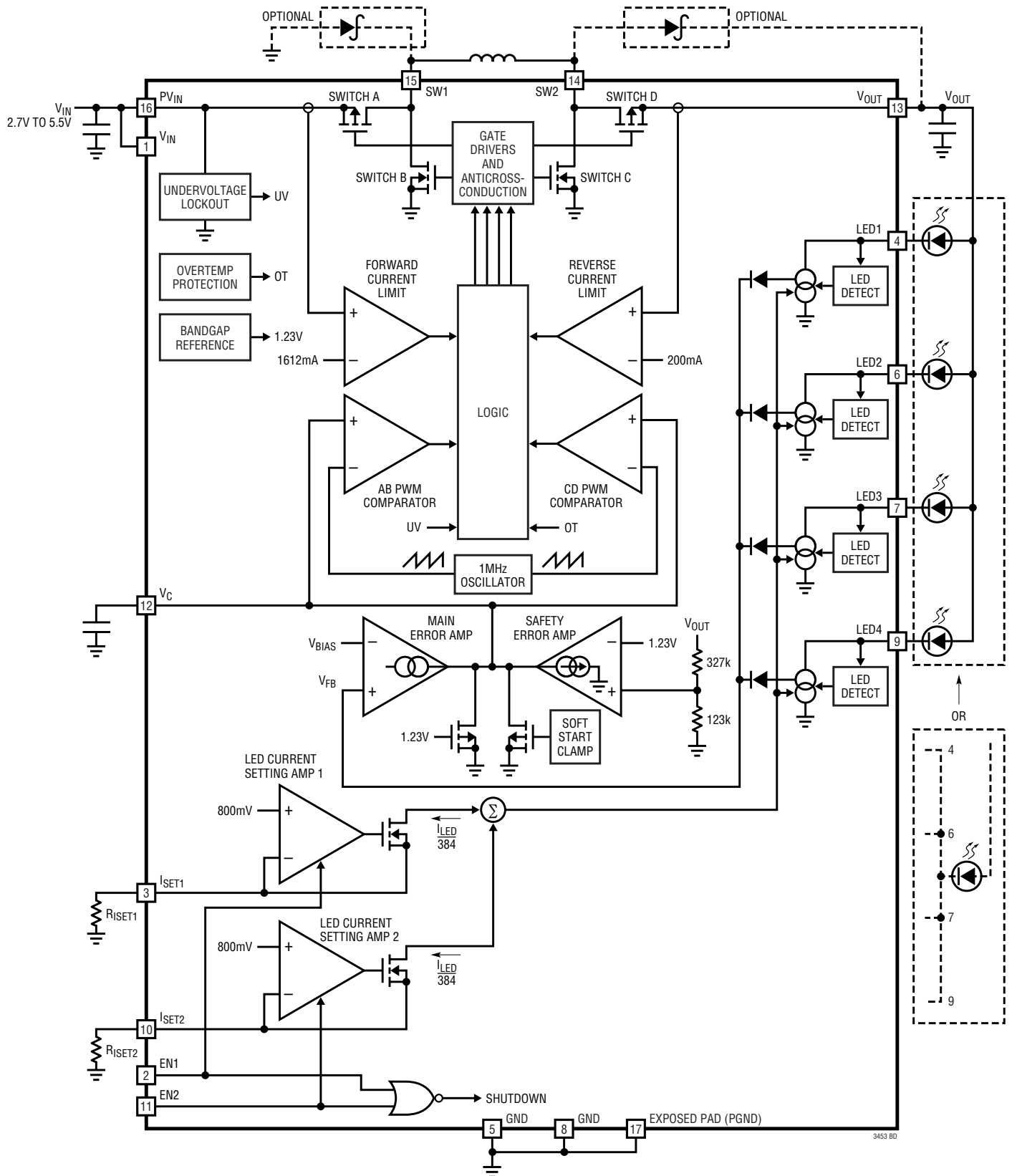

3453 BD

OPERATION

Buck-Boost DC-DC Converter

The LTC3453 employs an LTC proprietary buck-boost DC/DC converter to generate the output voltage required to drive the LEDs. This architecture permits high-efficiency, low noise operation at input voltages above, below or equal to the output voltage by properly phasing four internal power switches. The error amp output voltage on the V_C pin determines the duty cycle of the switches. Since the V_C pin is a filtered signal, it provides rejection of frequencies well below the factory trimmed switching frequency of 1MHz. The low $R_{DS(ON)}$, low gate charge synchronous switches provide high frequency pulse width modulation control at high efficiency. Schottky diodes across synchronous rectifier switch B and synchronous rectifier switch D are not required, but if used do provide a lower voltage drop during the break-before-make time (typically 20ns), which improves peak efficiency by typically 1% to 2% at higher loads.

Figure 1 shows a simplified diagram of how the four internal power switches are connected to the inductor, V_{IN} , V_{OUT} and GND. Figure 2 shows the regions of operation of the buck-boost as a function of the control voltage V_C . The output switches are properly phased so transitions between regions of operation are continuous, filtered and transparent to the user. When V_{IN} approaches V_{OUT} , the buck-boost region is reached where the conduction time of the four switch region is typically 150ns. Referring to Figures 1 and 2, the various regions of operation encountered as V_C increases will now be described.

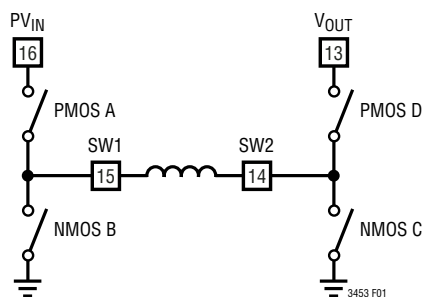

Figure 1. Simplified Diagram of Internal Power Switches

Buck Mode ($V_{IN} > V_{OUT}$)

In buck mode, switch D is always on and switch C is always off. Referring to Figure 2, when the control voltage V_C is above voltage V_1 , switch A begins to turn on each cycle. During the off time of switch A, synchronous rectifier switch B turns on for the remainder of the cycle. Switches A and B will alternate conducting similar to a typical synchronous buck regulator. As the control voltage increases, the duty cycle of switch A increases until the maximum duty cycle of the converter in buck mode reaches $DC_{BUCK|max}$ given by:

$$DC_{BUCK|max} = 100\% - DC_{4SW}$$

where DC_{4SW} equals the duty cycle in % of the “four switch” range.

$$DC_{4SW} = (150ns \cdot f) \cdot 100\%$$

where f is the operating frequency in Hz.

Beyond this point the “four switch” or buck-boost region is reached.

Buck-Boost or Four-Switch Mode ($V_{IN} \approx V_{OUT}$)

Referring to Figure 2, when the control voltage V_C is above voltage V_2 , switch pair AD continue to operate for duty cycle $DC_{BUCK|max}$, and the switch pair AC begins to phase in. As switch pair AC phases in, switch pair BD phases out accordingly. When the V_C voltage reaches the edge of the buck-boost range at voltage V_3 , switch pair AC completely phases out switch pair BD and the boost region begins at

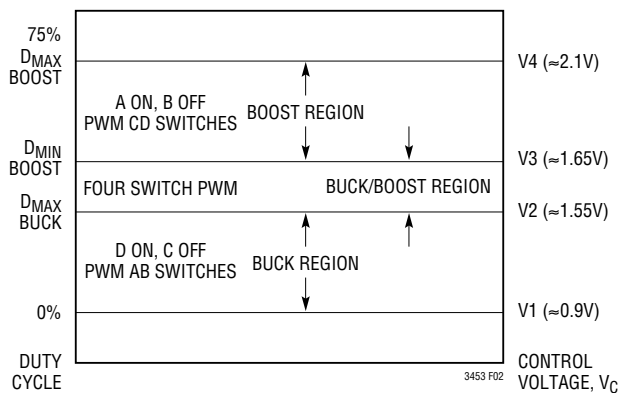

Figure 2. Switch Control vs Control Voltage, V_C

OPERATION

duty cycle DC_{4SW} . The input voltage V_{IN} where the four switch region begins is given by:

$$V_{IN} = V_{OUT} / [1 - (150\text{ns} \cdot f)]$$

and the input voltage V_{IN} where the four switch region ends is given by

$$V_{IN} = V_{OUT} / (1 - DC_{4SW}) = V_{OUT} \cdot [1 - (150\text{ns} \cdot f)]$$

Boost Mode ($V_{IN} < V_{OUT}$)

In boost mode, switch A is always on and switch B is always off. Referring to Figure 2, when the control voltage V_C is above voltage V3, switches C and D will alternate conducting similar to a typical synchronous boost regulator. The maximum duty cycle of the converter is limited to 88% typical and is reached when V_C is above V4.

Forward Current Limit

If the current delivered from V_{IN} through PMOS switch A exceeds 1612mA (typical), switch A is shut off immediately. Switches B and D are turned on for the remainder of the cycle in order to safely discharge the forward inductor current at the maximum rate possible.

Reverse Current Limit

If the current delivered from V_{OUT} backwards through PMOS switch D exceeds 200mA (typical), switch D is shut off immediately. Switches A and C are turned on for the remainder of the cycle in order to safely discharge the reverse inductor current at the maximum rate possible.

Undervoltage Lockout

To prevent operation of the power switches at high $R_{DS(ON)}$, an undervoltage lockout is incorporated on the LTC3453. When the input supply voltage drops below approximately 1.9V, the four power switches and all control circuitry are turned off except for the undervoltage block, which draws only several microamperes.

Overtemperature Protection

If the junction temperature of the LTC3453 exceeds 130°C for any reason, all four switches are shut off immediately. The overtemperature protection circuit has a typical hysteresis of 11°C.

Soft-Start

The LTC3453 includes an internally fixed soft-start which is active when powering up or coming out of shutdown. The soft-start works by clamping the voltage on the V_C node and gradually releasing it such that it requires 0.65ms to linearly slew from 0.9V to 2.1V. This has the effect of limiting the rate of duty cycle change as V_C transitions from the buck region through the buck-boost region into the boost region. Once the soft-start times out, it can only be reset by entering shutdown, or by an undervoltage or overtemperature condition.

Main Error Amp

The main error amplifier is a transconductance amplifier with source and sink capability. The output of the main error amplifier drives a capacitor to GND at the V_C pin. This capacitor sets the dominant pole for the regulation loop. (See the Applications Information section for selecting the capacitor value.) The error amp gets its feedback signal from a proprietary circuit which monitors all 4 LED current sources to determine which LED to close the regulation loop on.

Safety Error Amp

The safety error amplifier is a transconductance amplifier with sink only capability. In normal operation, it has no effect on the loop regulation. However, if any of the LED pins open-circuits, the output voltage will keep rising, and safety error amp will eventually take over control of the regulation loop to prevent V_{OUT} runaway. The V_{OUT} threshold at which this occurs is approximately 4.5V.

LED Current Setting Amplifiers and Enable Circuit

The LTC3453 includes two LED current setting amplifiers that work in conjunction with dual external current setting resistors and dual enable pins to program LED current to one of four levels (including shutdown). All four LED current source outputs are programmed to the same level. When both enable inputs are logic low, the LTC3453 is in shutdown, the buck-boost is disabled and all LED currents are zero. In shutdown, the input supply current is typically 6 μ A. If either enable input is logic high, the buck-boost will regulate the output voltage such that the LEDs are biased

LTC3453

OPERATION

at the current programmed by resistors R_{ISET1} and/or R_{ISET2} . Individually enabled, each LED current setting amplifier programs the output LED current to

$$I_{LED} = 384 (0.8V/R_{ISET1,2})$$

If both enable inputs are logic high, the setting currents are summed internally and the output LED current will be given by

$$I_{LED} = 384 [0.8V/(R_{ISET1} || R_{ISET2})]$$

Thus three different (nonzero) current levels are programmable, optimal for low current LED torch and high current LED camera flash applications.

LED Current Sources

Each LED pin is driven by a current source specifically designed for low dropout. The LTC3453 employs a propri-

etary architecture that determines which of the four LEDs requires the largest forward voltage drop at its programmed current, and then generates a feedback voltage based on this one for closing the buck-boost regulation loop. This results in the lowest output voltage required for regulating all of the LEDs and thus the highest LED power efficiency. The voltage present at the LED pin of the “controlling LED” will be typically 130mV at 75mA of current.

LED Detect Circuit

If fewer than four LED outputs are required, unused ones should be connected to V_{OUT} . Each LED pin has an internal LED detect circuit that disables the output current source to save power if an output is not needed. A small 30 μ A current is employed to detect the presence of an LED at startup.

APPLICATIONS INFORMATION

Component Selection

Inductor Selection

The high frequency operation of the LTC3453 allows the use of small surface mount inductors. The inductor current ripple is typically set to 20% to 40% of the maximum inductor current. For a given ripple the inductance terms are given as follows:

$$L > \frac{V_{IN(MIN)}^2 \cdot (V_{OUT} - V_{IN(MIN)}) \cdot 100\%}{f \cdot I_{OUT(MAX)} \cdot \%Ripple \cdot V_{OUT}^2},$$

$$L > \frac{V_{OUT} \cdot (V_{IN(MAX)} - V_{OUT}) \cdot 100\%}{f \cdot I_{OUT(MAX)} \cdot \%Ripple \cdot V_{IN(MAX)}}$$

where f = operating frequency, Hz

%Ripple = allowable inductor current ripple, %

$V_{IN(MIN)}$ = minimum input voltage, V

$V_{IN(MAX)}$ = maximum input voltage, V

V_{OUT} = output voltage, V

$I_{OUT(MAX)}$ = maximum output load current

For high efficiency, choose an inductor with a high frequency core material, such as ferrite, to reduce core losses. The inductor should have low ESR (equivalent series resistance) to reduce the I^2R losses, and must be able to handle the peak inductor current without saturating. Molded chokes or chip inductors usually do not have enough core to support peak inductor currents >1A. To minimize radiated noise, use a toroid, pot core or shielded bobbin inductor. For the white LED application, a 4.7 μ H inductor value is recommended. See Table 1 for a list of component suppliers.

Table 1. Inductor Vendor Information

SUPPLIER	WEB SITE
Coilcraft	www.coilcraft.com
Cooper/Coiltronics	www.cooperet.com
Murata	www.murata.com
Sumida	www.japanlink.com/sumida
Vishay-Dale	www.vishay.com

APPLICATIONS INFORMATION

Input Capacitor Selection

Since the V_{IN} pin is the supply voltage for the IC it is recommended to place at least a 2.2 μ F, low ESR bypass capacitor to ground. See Table 2 for a list of component suppliers.

Table 2. Capacitor Vendor Information

SUPPLIER	WEB SITE
AVX	www.avxcorp.com
Sanyo	www.sanyovideo.com
Taiyo Yuden	www.t-yuden.com
TDK	www.component.tdk.com

Output Capacitor Selection

The bulk value of the capacitor is set to reduce the ripple due to charge into the capacitor each cycle. The steady state ripple due to charge is given by:

$$\%Ripple_Boost = \frac{I_{OUT(MAX)} \cdot (V_{OUT} - V_{IN(MIN)}) \cdot 100}{C_{OUT} \cdot V_{OUT}^2 \cdot f} \%$$

$$\%Ripple_Buck = \frac{I_{OUT(MAX)} \cdot (V_{IN(MAX)} - V_{OUT}) \cdot 100}{C_{OUT} \cdot V_{IN(MAX)} \cdot V_{OUT} \cdot f} \%$$

where C_{OUT} = output filter capacitor, F

The output capacitance is usually many times larger in order to handle the transient response of the converter. For a rule of thumb, the ratio of the operating frequency to the unity-gain bandwidth of the converter is the amount the output capacitance will have to increase from the above calculations in order to maintain the desired transient response.

The other component of ripple is due to the ESR (equivalent series resistance) of the output capacitor. Low ESR capacitors should be used to minimize output voltage ripple. For surface mount applications, Taiyo Yuden, TDK, AVX ceramic capacitors, AVX TPS series tantalum capacitors or Sanyo POSCAP are recommended. For the white LED application, a 4.7 μ F capacitor value is recommended. See Table 2 for a list of component suppliers.

Optional Schottky Diodes

Schottky diodes across the synchronous switches B and D are not required, but provide a lower drop during the break-before-make time (typically 20ns) of the NMOS to PMOS transition, improving efficiency. Use a Schottky diode such as an MBRM120T3 or equivalent. Do not use ordinary rectifier diodes, since the slow recovery times will compromise efficiency.

Closing the Feedback Loop

The LTC3453 incorporates voltage mode PWM control. The control to output gain varies with operation region (Buck, Boost, Buck/Boost), but is usually no greater than 15. The output filter exhibits a double pole response given by:

$$f_{FILTER_POLE} = \frac{1}{2 \cdot \pi \cdot \sqrt{L \cdot C_{OUT}}} \text{ Hz}$$

where C_{OUT} is the output filter capacitor.

The output filter zero is given by:

$$f_{FILTER_ZERO} = \frac{1}{2 \cdot \pi \cdot R_{ESR} \cdot C_{OUT}} \text{ Hz}$$

where R_{ESR} is the capacitor equivalent series resistance.

A troublesome feature in Boost mode is the right-half plane zero (RHP), and is given by:

$$f_{RHPZ} = \frac{V_{IN}^2}{2 \cdot \pi \cdot I_{OUT} \cdot L \cdot V_{OUT}} \text{ Hz}$$

The loop gain is typically rolled off before the RHP zero frequency.

A simple Type I compensation network can be incorporated to stabilize the loop but at a cost of reduced bandwidth and slower transient response. To ensure proper phase margin, the loop requires to be crossed over a decade before the LC double pole.

APPLICATIONS INFORMATION

The unity-gain frequency of the error amplifier with the Type I compensation is given by:

$$f_{UG} = \frac{g_m}{2 \cdot \pi \cdot C_{VC}}$$

where g_m is the error amp transconductance (typically 1/5.2k) and C_{VC} is the external capacitor to GND at the V_C pin. For the white LED application, a 0.1 μ F or greater capacitor value is recommended.

Paralleling LED Outputs for Higher Current

Two or more LED output pins can be connected together in parallel to achieve higher output current in fewer than 4 LEDs. For a very high power LED such as a LumiLED, all four outputs can be connected in parallel for maximum total output current, as shown in the cover page application of this datasheet.

Maximum LED Current

As described in the Operation section, the output LED current with both enable pins logic high is equal to

$$I_{LED} = 384 [0.8V / (R_{ISET1} \parallel R_{ISET2})]$$

Since the maximum continuous output current is limited to 500mA, this sets a minimum limit on the parallel combination of R_{ISET1} and R_{ISET2} equal to

$$R_{MIN} = (R_{ISET1} \parallel R_{ISET2})_{MIN} = 4(384[0.8V/500mA]) = 2458\Omega$$

Although the LTC3453 can safely provide this current continuously, the external LED(s) may not be rated for this high a level of continuous current. Higher current levels are generally reserved for pulsed applications, such as LED camera flash. This is accomplished by programming a high current with one of the R_{ISET} resistors and pulsing the appropriate enable pin.

Varying LED Brightness

Continuously variable LED brightness control can be achieved by interfacing directly to one or both of the I_{SET} pins. Figure 3 shows four such methods employing a voltage DAC, a current DAC, a simple potentiometer or a PWM input. It is not recommended to control brightness by PWMing the enable pins directly as this will toggle the LTC3453 in and out of shutdown and result in erratic operation.

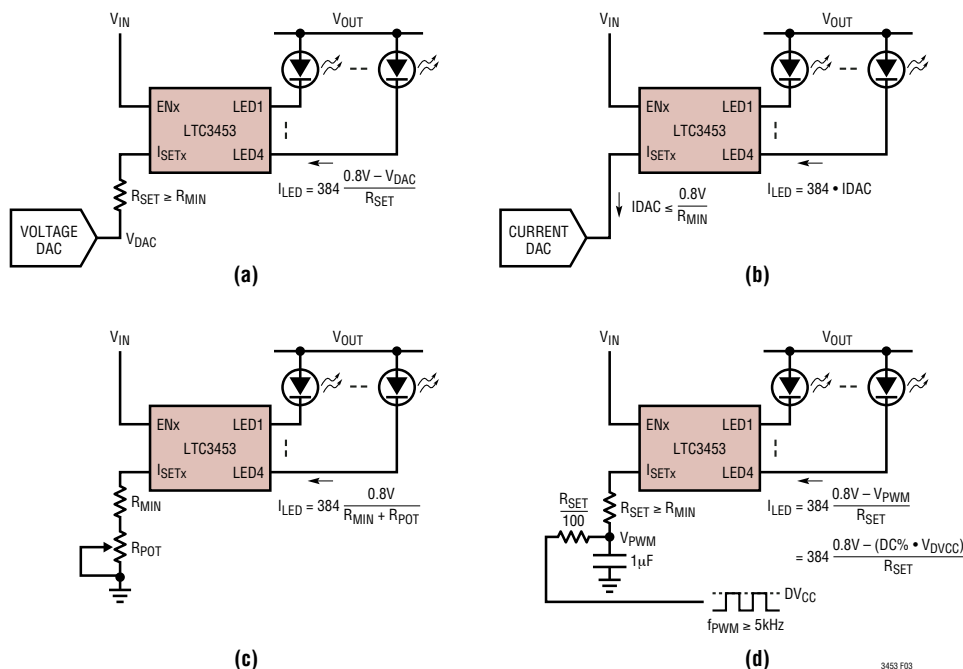

3453 F03

Figure 3. Brightness Control Methods: (a) Using Voltage DAC, (b) Using Current DAC, (c) Using Potentiometer, (d) Using PWM Input

APPLICATIONS INFORMATION

Unused Outputs

If fewer than 4 LED pins are to be used, unused LEDx pins should be connected to V_{OUT} . The LTC3453 senses which current source outputs are not being used and shuts off the corresponding output currents to save power. A small trickle current ($\sim 30\mu A$) is still applied to unused outputs to detect if a white LED is later switched in and also to distinguish unused outputs from used outputs during startup.

LED Failure Modes

If an individual LED fails as a short circuit, the current source biasing it is shut off to save power. This is the same

operation as described previously (if the output were initially designated unused at power-up by connecting its LEDx pin to V_{OUT}). Efficiency is not materially affected.

If an individual LED fails as an open circuit, the control loop will initially attempt to regulate off of its current source feedback signal, since it will appear to be the one requiring the largest forward voltage drop to run at its programmed current. This will drive V_{OUT} higher. As the open circuited LED will never accept its programmed current, V_{OUT} must be voltage-limited by means of a secondary control loop. The LTC3453 limits V_{OUT} to 4.5V in this failure mode. The other LEDs will still remain biased at the correct programmed current but the overall circuit efficiency will decrease.

PACKAGE DESCRIPTION

UF Package
16-Lead Plastic QFN (4mm × 4mm)
(Reference LTC DWG # 05-08-1692)

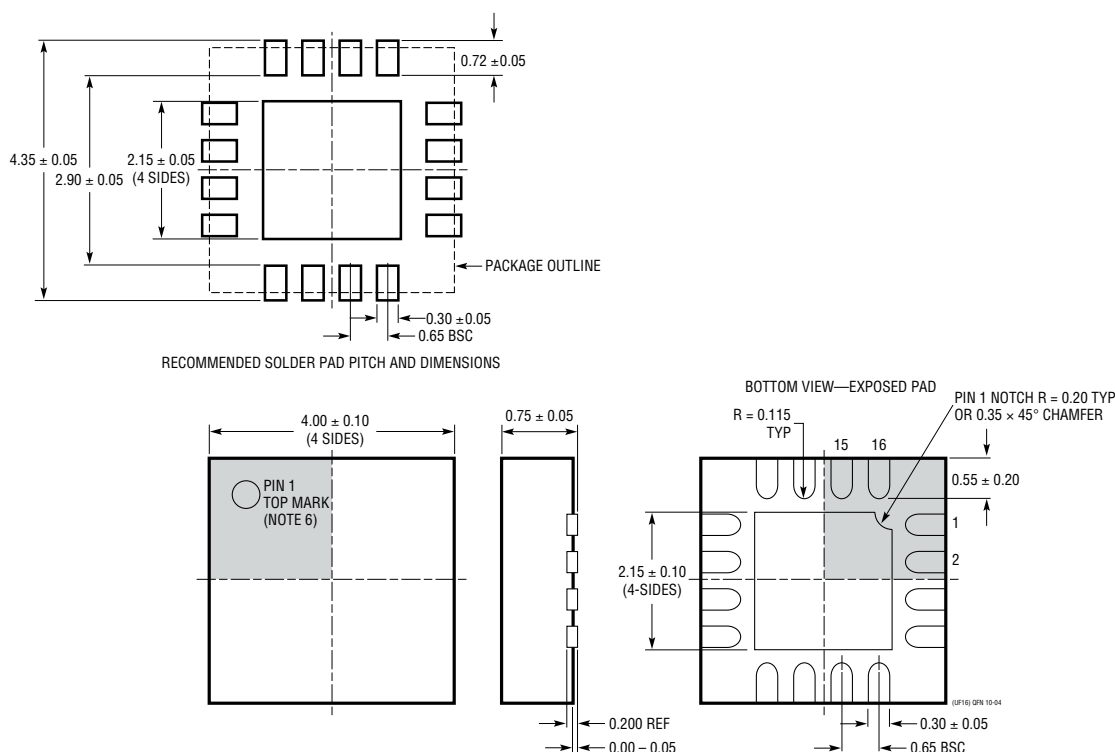

TYPICAL APPLICATION

High Efficiency 4 White LED Driver

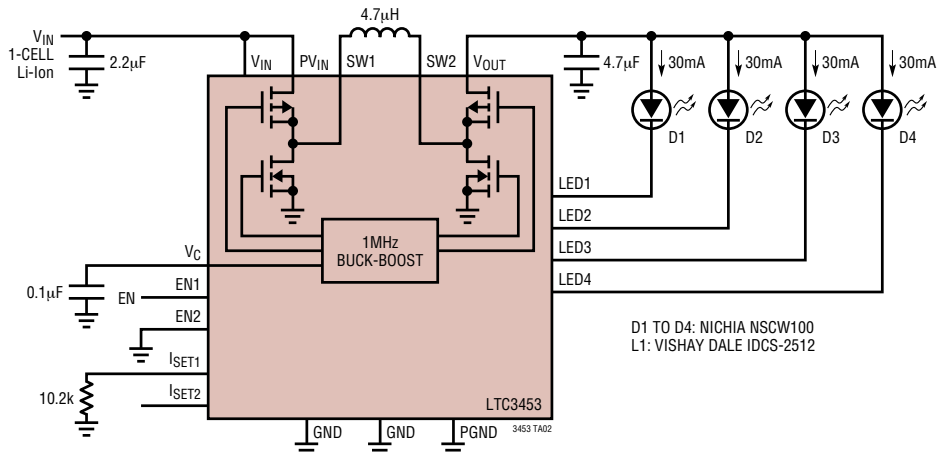

RELATED PARTS

PART NUMBER	DESCRIPTION	COMMENTS
LT1618	Constant Current, Constant Voltage 1.4MHz, High Efficiency Boost Regulator	V_{IN} : 1.6V to 18V, $V_{OUT(MAX)}$ = 34V, I_Q = 1.8mA, I_{SD} = <1µA, MS10 Package/EDD Package
LT1930/LT1930A	1A (I_{SW}), 1.2MHz/2.2MHz, High Efficiency Step-Up DC/DC Converter	V_{IN} : 2.6V to 16V, $V_{OUT(MAX)}$ = 34V, I_Q = 4.2mA/5.5mA, I_{SD} = <1µA, ThinSOT Package
LT1932	Constant Current, 1.2MHz, High Efficiency White LED Boost Regulator	V_{IN} : 1V to 10V, $V_{OUT(MAX)}$ = 34V, I_Q = 1.2mA, I_{SD} = <1µA, ThinSOT Package
LT1937	Constant Current, 1.2MHz, High Efficiency White LED Boost Regulator	V_{IN} : 2.5V to 10V, $V_{OUT(MAX)}$ = 34V, I_Q = 1.9mA, I_{SD} = <1µA, ThinSOT Package/SC70 Package
LTC3205	High Efficiency, Multi-Display LED Controller	V_{IN} : 2.8V to 4.5V, $V_{OUT(MAX)}$ = 6V, I_Q = 50µA, I_{SD} = <1µA, QFN-24 Package
LTC3216	1A Low Noise High Current LED Charge Pump with Independent Flash/Torch Current	V_{IN} : 2.9V to 4.4V, $V_{OUT(MAX)}$ = 5.5V, I_Q = 300µA, I_{SD} = <2.5µA, DFN Package
LTC3440/ LTC3441	600mA/1.2A I_{OUT} , 2MHz/1MHz, Synchronous Buck-Boost DC/DC Converter	V_{IN} : 2.4V to 5.5V, $V_{OUT(MAX)}$ = 5.25V, I_Q = 25µA/50µA, I_{SD} = <1µA, MS-10 Package/DFN Package
LTC3443	600mA/1.2A I_{OUT} , 600kHz, Synchronous Buck-Boost DC/DC Converter	V_{IN} : 2.4V to 5.5V, $V_{OUT(MAX)}$ = 5.25V, I_Q = 28µA, I_{SD} = <1µA, DFN Package
LT3465/LT3465A	Constant Current, 1.2MHz/2.7MHz, High Efficiency White LED Boost Regulator with Integrated Schottky Diode	V_{IN} : 2.7V to 16V, $V_{OUT(MAX)}$ = 34V, I_Q = 1.9mA, I_{SD} = <1µA, ThinSOT Package
LT3466	Dual Constant Current, 2MHz, High Efficiency White LED Boost Regulator with Integrated Schottky Diode	V_{IN} : 2.7V to 24V, $V_{OUT(MAX)}$ = 40V, I_Q = 5mA, I_{SD} = <16µA, DFN Package
LT3479	3A, Full Featured DC/DC Converter with Soft-Start and Inrush Current Protection	V_{IN} : 2.5V to 24V, $V_{OUT(MAX)}$ = 40V, I_Q = 6.5mA, I_{SD} = <1µA, DFN Package/TSOPP Package