



# LT3462/LT3462A

## Inverting 1.2MHz/2.7MHz DC/DC Converters with Integrated Schottky in ThinSOT

### FEATURES

- Integrated Schottky Rectifier
- Fixed Frequency 1.2MHz/2.7MHz Operation
- Very Low Noise: 1mV<sub>P-P</sub> Output Ripple
- Low V<sub>CESAT</sub> Switch: 270mV at 250mA
- -5V at 100mA from 5V Input
- -12V at 30mA from 3.3V Input
- Low Input Bias Current GND Based FB Input
- Low Impedance (40Ω) 1.265V Reference Output
- High Output Voltage: Up to -38V
- Wide Input Range: 2.5V to 16V
- Uses Tiny Surface Mount Components
- Low Shutdown Current: <10μA
- Low Profile (1mm) SOT-23 (ThinSOT™) Package

### APPLICATIONS

- CCD Bias
- LCD Bias
- GaAs FET Bias
- General Purpose Negative Voltage Supply

LT, LTC and LT are registered trademarks of Linear Technology Corporation.  
ThinSOT is a trademark of Linear Technology Corporation

### DESCRIPTION

The LT<sup>®</sup>3462/LT3462A are general purpose fixed frequency current mode inverting DC/DC converters. Both devices feature an integrated Schottky and a low V<sub>CESAT</sub> switch allowing a small converter footprint and lower parts cost. The LT3462 switches at 1.2MHz while the LT3462A switches at 2.7MHz. These high speeds enable the use of tiny, low cost and low height capacitors and inductors.

The LT3462/LT3462A operate in a dual inductor inverting topology that filters both the input and output currents. Very low output voltage ripple approaching 1mV<sub>P-P</sub> can be achieved when ceramic capacitors are used. Fixed frequency switching ensures a clean output free from low frequency noise typically present with charge pump solutions. The 40V switch allows a V<sub>IN</sub> to V<sub>OUT</sub> differential of up to 38V for dual inductor topologies.

Both devices provide a low impedance 1.265V reference output to supply the feedback resistor network. A ground referenced, high impedance FB input allows high feedback resistor values without compromising output accuracy.

The LT3462/LT3462A are available in a 6-lead SOT-23 package.

### TYPICAL APPLICATION

5V to -5V, 100mA Inverting DC/DC Converter

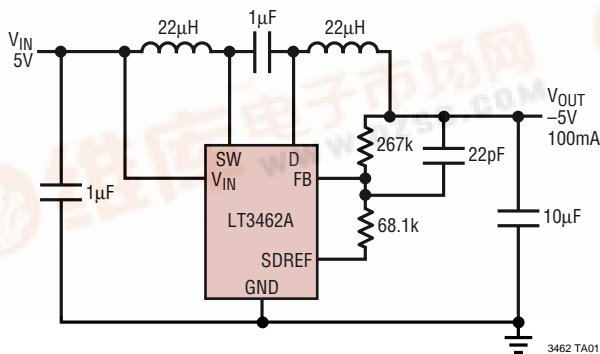

Efficiency

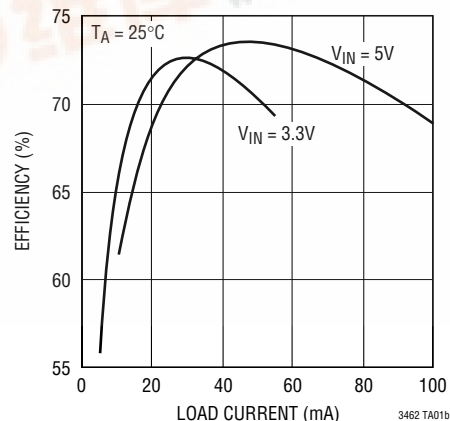

# LT3462/LT3462A

## ABSOLUTE MAXIMUM RATINGS

(Note 1)

Input Voltage ( $V_{IN}$ ) .....	16V
SW Voltage .....	40V
D Voltage .....	-40V
SDREF, FB Voltage .....	2.5V
Operating Ambient Temperature Range (Note 3) .....	-40°C to 85°C
Maximum Junction Temperature .....	125°C
Storage Temperature Range .....	-65°C to 150°C
Lead Temperature (Soldering, 10sec) .....	300°C

## PACKAGE/ORDER INFORMATION

	ORDER PART NUMBER
	LT3462ES6 LT3462AES6
	S6 PART MARKING
	LTBBV LTBGB

Consult LTC Marketing for parts specified with wider operating temperature ranges.

## ELECTRICAL CHARACTERISTICS

The ● denotes the specifications which apply over the full operating temperature range, otherwise specifications are at  $T_A = 25^\circ\text{C}$ ,  $V_{IN} = 3\text{V}$ , unless otherwise noted.

PARAMETER	CONDITIONS	MIN	TYP	MAX	UNITS
Minimum Operating Voltage		2.5			V
Maximum Operating Voltage				16	V
SDREF Voltage	$10\mu\text{A} > I_{SDREF} \geq -80\mu\text{A}$	● 1.245	1.265	1.285	V
FB Pin Bias Current (Note 2)			15	50	nA
SDREF Minus FB Voltage	$10\mu\text{A} > I_{SDREF} \geq -80\mu\text{A}$	● 1.235	1.263	1.285	V
Error Amp Offset Voltage		-12		12	mV
SDREF Reference Source Current	SDREF > 1.2V	● 120	180		$\mu\text{A}$
Supply Current	FB = -0.05V, Not Switching SDREF = 0V, FB = Open, $V_{IN} = 5\text{V}$		2.9 6.5	3.6 10	mA $\mu\text{A}$
SDREF Line Regulation			0.007		%/V
Switching Frequency (LT3462)		● 0.8	1.2	1.6	MHz
Switching Frequency (LT3462A)		● 2.0	2.7	3.5	MHz
Maximum Duty Cycle (LT3462)		● 90			%
Maximum Duty Cycle (LT3462A)		● 77			%
Switch Current Limit		300	420		mA
Switch $V_{CESAT}$	$I_{SW} = 250\text{mA}$		270	350	mV
Switch Leakage Current	$V_{SW} = 5\text{V}$		0.01	1	$\mu\text{A}$
Rectifier Leakage Current	$V_D = -40\text{V}$		0.03	4	$\mu\text{A}$
Rectifier Forward Drop	$I_{SCHOTTKY} = 250\text{mA}$		800	1100	mV
SDREF Voltage Low		●		0.20	V
SDREF Off-State Pull-Up Current		1	2	3	$\mu\text{A}$
SDREF Turn-Off Current		-300	-200		$\mu\text{A}$

**Note 1:** Absolute Maximum Ratings are those values beyond which the life of a device may be impaired.

**Note 2:** Current flows out of the pin.

**Note 3:** The LT3462E is guaranteed to meet specifications from 0°C to 70°C. Specifications over the -40°C to 85°C operating temperature range are assured by design, characterization and correlation with statistical process controls.

## TYPICAL PERFORMANCE CHARACTERISTICS

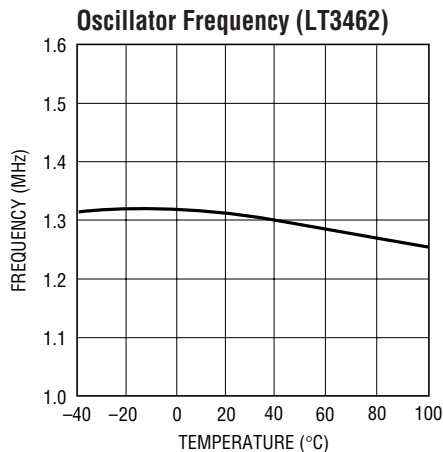

3462 G01

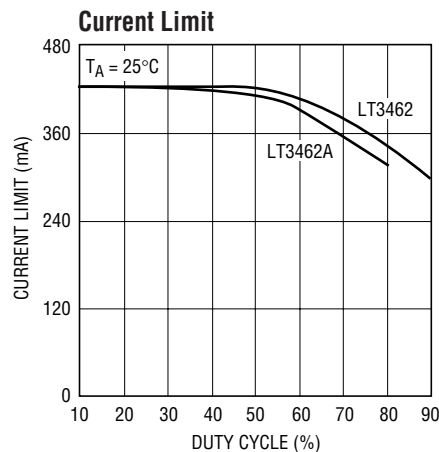

3462 G02

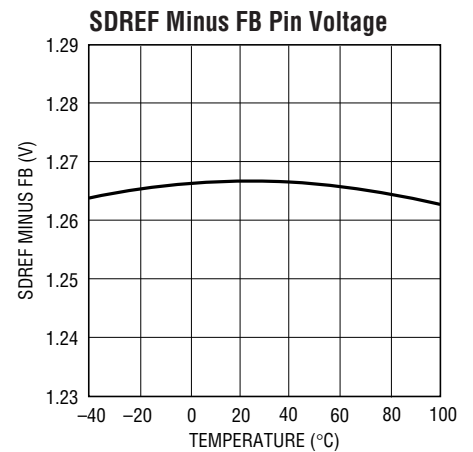

3462 G03

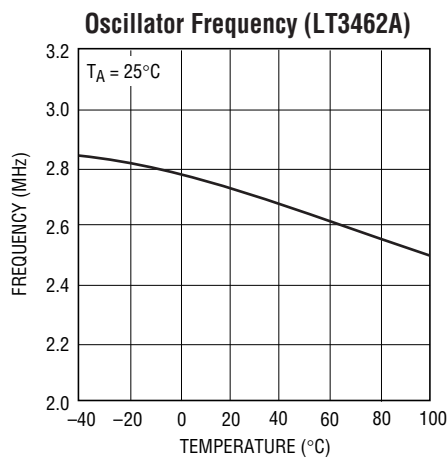

3462 G04

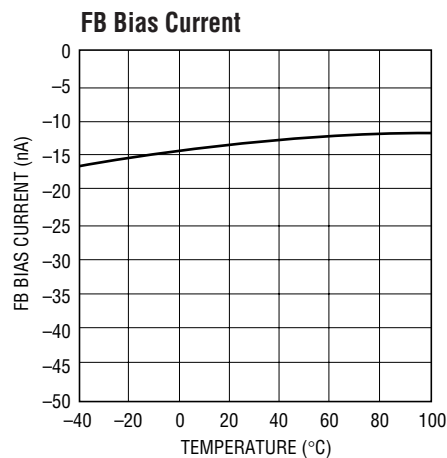

3462 G05

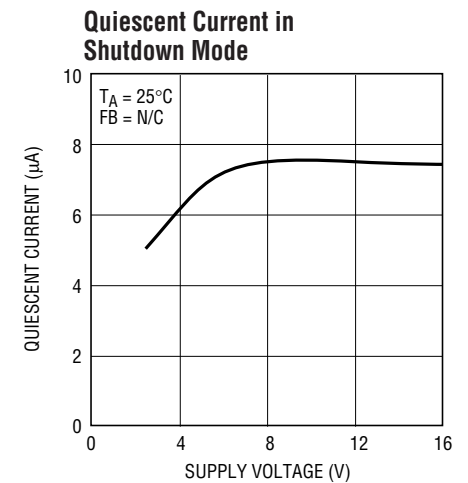

3462 G06

## PIN FUNCTIONS

**SW (Pin 1):** Switch Pin. Connect to external inductor L1 and positive terminal of transfer cap.

**GND (Pin 2):** Ground. Tie directly to local ground plane.

**FB (Pin 3):** Feedback Pin. Connect resistive divider tap here. Set R1 according to  $R1 = R2 \cdot (V_{OUT}/1.265V)$ . In shutdown, a proprietary shutdown bias current cancellation circuit allows the internal 3µA source to pull up the SDREF pin, even with residual negative voltage on  $V_{OUT}$ .

**SDREF (Pin 4):** Dual Function Shutdown and 1.265V Reference Output Pin. Pull to GND with external N-FET to

turn regulator off. Turn-off pull-down and a 2µA internal source will pull SDREF up to turn-on the regulator. At turn-on, a 180µA internal source pulls the pin to the regulation voltage. The SDREF pin can supply up to 80µA at 1.265V to bias the feedback resistor divider. An optional soft-start circuit capacitor connects from this pin to  $-V_{OUT}$ .

**D (Pin 5):** Anode Terminal of Integrated Schottky Diode. Connect to negative terminal of transfer cap and external inductor L2.

**$V_{IN}$  (Pin 6):** Input Supply Pin. Must be locally bypassed.



## APPLICATIONS INFORMATION

### Inrush Current

The LT3462 has a built-in Schottky diode. When supply voltage is applied to the  $V_{IN}$  pin, the voltage difference between  $V_{IN}$  and  $V_D$  generates inrush current flowing from input through the inductor and the Schottky diode to charge the flying capacitor to  $V_{IN}$ . The maximum nonrepetitive surge current the Schottky diode in the LT3462 can sustain is 1.5A. The selection of inductor and capacitor value should ensure the peak of the inrush current to be below 1.5A. The peak inrush current can be calculated as follows:

$$I_P = \frac{V_{IN} - 0.6}{\sqrt{\frac{L}{C} - 1}} \exp\left(-\frac{\pi}{2\sqrt{\frac{L}{C} - 1}}\right)$$

where L is the inductance between supply and SW, and C is the capacitance between SW and D.

Table 3 gives inrush peak currents for some component selections.

**Table 3. Inrush Peak Current**

$V_{IN}$ (V)	L ( $\mu$ H)	C ( $\mu$ F)	$I_P$ (A)
5	22	1	0.70
5	33	1	0.60
12	47	1	1.40

### Inductor Selection

Each of the two inductors used with LT3462 should have a saturation current rating (where inductance is approximately 70% of zero current inductance) of approximately 0.25A or greater. If the device is used in the charge pump mode, where there is only one inductor, then its rating should be 0.35A or greater. DCR of the inductors should be less than 1 $\Omega$ . For LT3462, a value of 22 $\mu$ H is suitable if using a coupled inductor such as Sumida CLS62-220. If using two separate inductors, increasing the value to 47 $\mu$ H will result in the same ripple current. For LT3462A, a value of 10 $\mu$ H for the coupled inductor and 22 $\mu$ H for two inductors will be acceptable for most applications.

### Capacitor Selection

Ceramic capacitors are recommended. An X7R or X5R dielectric should be used to avoid capacitance decreasing severely with applied voltage and at temperature limits. The “flying” capacitor between the SW and D pins should be a ceramic type of value 1 $\mu$ F or more. When used in the dual inductor or coupled inductor topologies the flying capacitor should have a voltage rating that is more than the difference between the input and output voltages. For the charge pump inverter topology, the voltage rating should be more than the output voltage. The output capacitor should be a ceramic type. Acceptable output capacitance varies from 1 $\mu$ F for high  $V_{OUT}$  (–36V), to 10 $\mu$ F for low  $V_{OUT}$  (–5V). The input capacitor should be a 1 $\mu$ F ceramic type and be placed as close as possible to the LT3462/LT3462A.

### Layout Hints

The high speed operation of the LT3462 demands careful attention to board layout. You will not get advertised performance with careless layout. Figure 2 shows the recommended component placement. A ceramic capacitor of 1 $\mu$ F or more must be placed close to the IC for input supply bypassing.

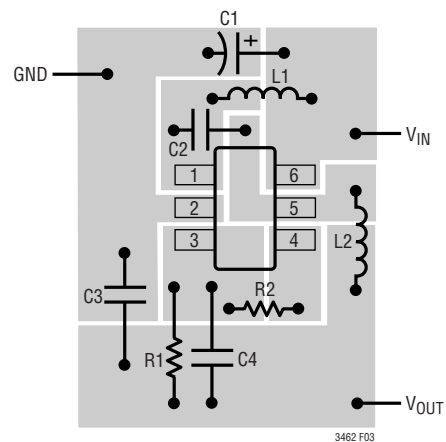
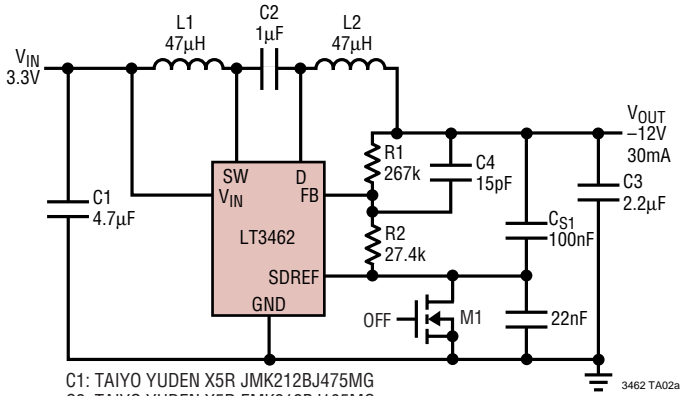

**Figure 2. Suggested Layout**

# LT3462/LT3462A

## TYPICAL APPLICATIONS

3.3V to -12V with Soft-Start Circuit



- C1: TAIYO YUDEN X5R JMK212BJ475MG
- C2: TAIYO YUDEN X5R EMK212BJ105MG
- C3: TAIYO YUDEN EMK316BJ225
- L1, L2: MURATA LQH32CN470

-12V Efficiency

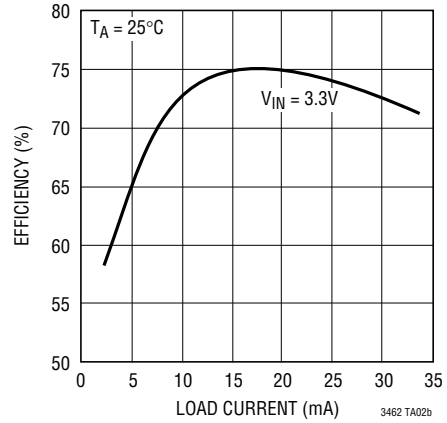

$V_{OUT}$  Reaches -12V in 750µs; Input Current Peaks at 300mA without  $C_{S1}$

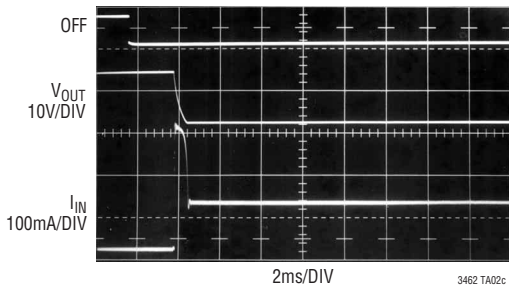

$V_{OUT}$  Reaches -12V in 7.5ms; Input Current Peaks at 125mA with  $C_{S1} = 100nF$

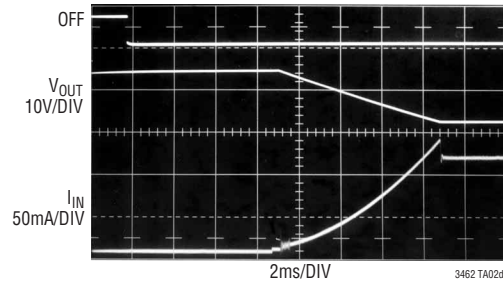

Li+ to -8V Supply

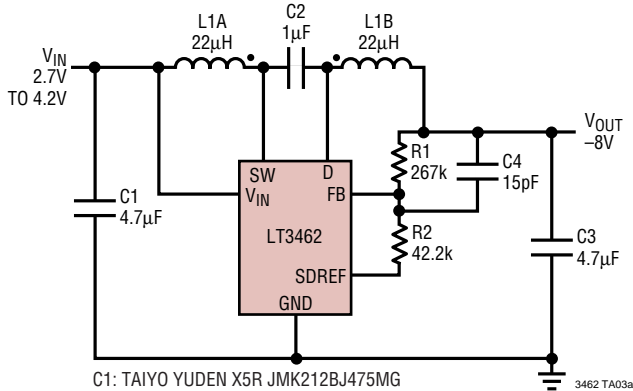

- C1: TAIYO YUDEN X5R JMK212BJ475MG
- C2: TAIYO YUDEN X5R EMK212BJ105MG
- C3: TAIYO YUDEN LMK316BJ475
- L1: SUMIDA CLS62-220 OR 2X MURATA LQH32CN330

-8V Efficiency

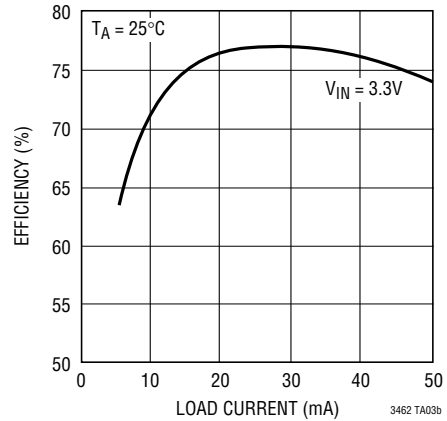

## TYPICAL APPLICATIONS

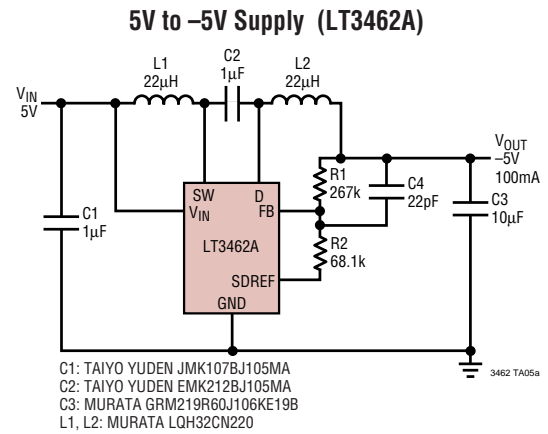
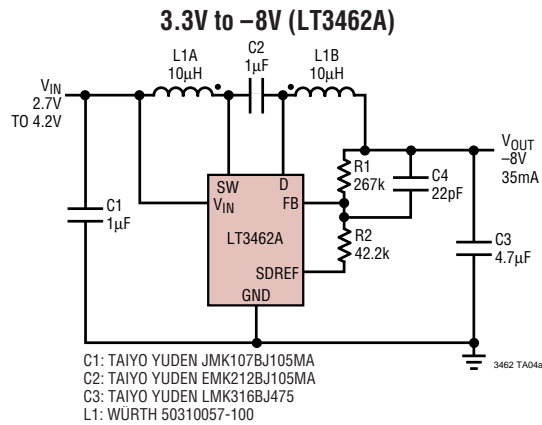

### Switching Waveform

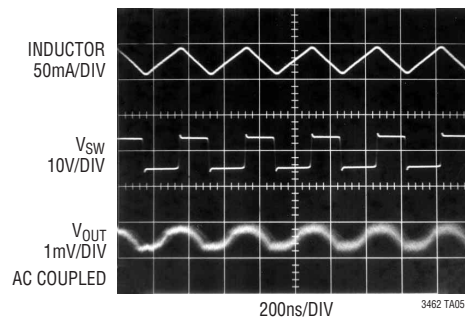

## PACKAGE DESCRIPTION

### S6 Package 6-Lead Plastic TSOT-23 (Reference LTC DWG # 05-08-1636)

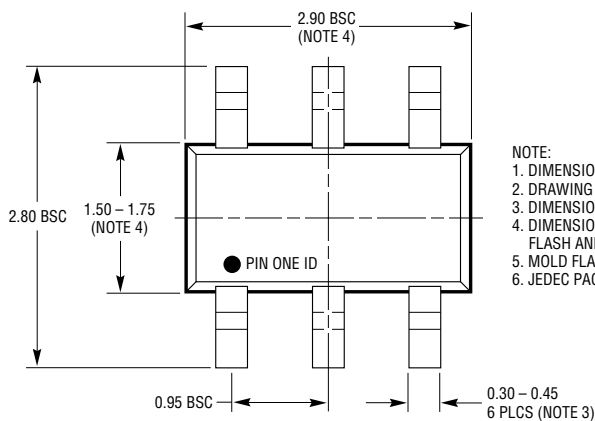
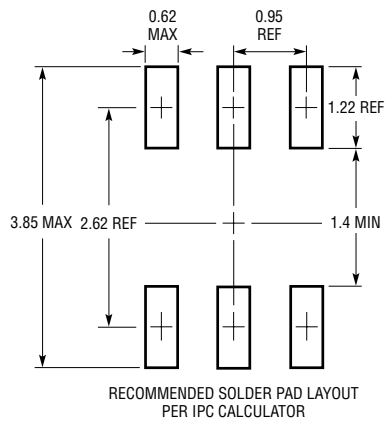

- NOTE:
1. DIMENSIONS ARE IN MILLIMETERS
  2. DRAWING NOT TO SCALE
  3. DIMENSIONS ARE INCLUSIVE OF PLATING
  4. DIMENSIONS ARE EXCLUSIVE OF MOLD FLASH AND METAL BURR
  5. MOLD FLASH SHALL NOT EXCEED 0.254mm
  6. JEDEC PACKAGE REFERENCE IS MO-193

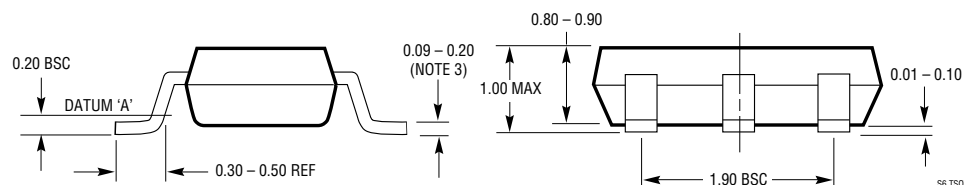

# LT3462/LT3462A

## TYPICAL APPLICATIONS

12V to -36V DC/DC Converter

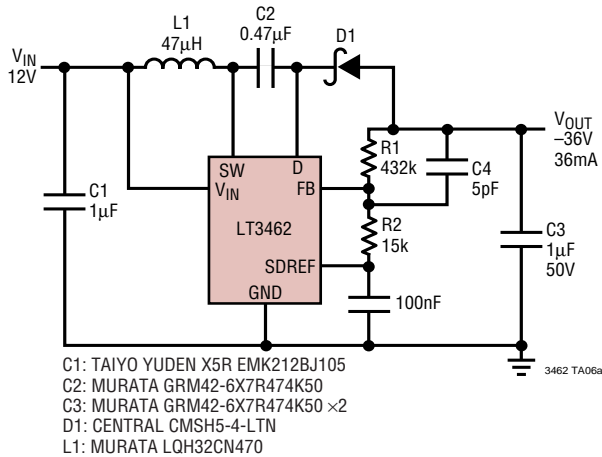

-36V Efficiency

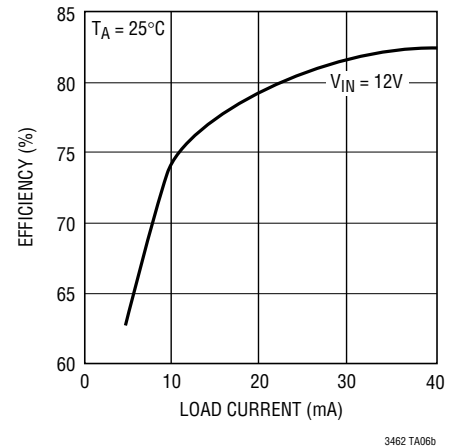

## RELATED PARTS

PART NUMBER	DESCRIPTION	COMMENTS
LT1617/LT1617-1	350mA/100mA ( $I_{SW}$ ) High Efficiency Micropower Inverting DC/DC Converter	$V_{IN}$ : 1.2V to 15V, $V_{OUT(MAX)}$ = -34V, $I_Q$ = 20µA, $I_{SD}$ < 1µA ThinSOT Package
LT1931/LT1931A	1A ( $I_{SW}$ ), 1.2MHz/2.2MHz, High Efficiency Micropower Inverting DC/DC Converter	$V_{IN}$ : 2.6V to 16V, $V_{OUT(MAX)}$ = -34V, $I_Q$ = 5.8mA, $I_{SD}$ < 1µA ThinSOT Package
LT1945	Dual Output, Boost/Inverter, 350mA ( $I_{SW}$ ), Constant Off-Time, High Efficiency Step-Up DC/DC Converter	$V_{IN}$ : 1.2V to 15V, $V_{OUT(MAX)}$ = ±34V, $I_Q$ = 40µA, $I_{SD}$ < 1µA, MS10 Package
LT1946/LT1946A	1.5A ( $I_{SW}$ ), 1.2MHz/2.7MHz, High Efficiency Step-Up DC/DC Converter	$V_{IN}$ : 2.45V to 16V, $V_{OUT(MAX)}$ = 34V, $I_Q$ = 3.2mA, $I_{SD}$ < 1µA MS8 Package
LT3463	Dual Output, Boost/Inverter, 250mA ( $I_{SW}$ ), Constant Off-Time, High Efficiency Step-Up DC/DC Converter with Integrated Schottky Diodes	$V_{IN}$ : 2.3V to 15V, $V_{OUT(MAX)}$ = ±40V, $I_Q$ = 40µA, $I_{SD}$ < 1µA DFN Package
LT3464	85mA ( $I_{SW}$ ), High Efficiency Step-Up DC/DC Converter with Integrated Schottky and PNP Disconnect	$V_{IN}$ : 2.3V to 10V, $V_{OUT(MAX)}$ = 34V, $I_Q$ = 25µA, $I_{SD}$ < 1µA ThinSOT Package