



LT3477

3A, DC/DC Converter with Dual Rail-to-Rail Current Sense

FEATURES

- Dual 100mV Rail-to-Rail Current Sense Amplifiers
- Wide Input Voltage Range: 2.5V to 25V
- 3A, 42V Internal Switch
- High Efficiency Power Conversion: Up to 91%
- Drives LEDs in Buck, Buck-Boost or Boost Mode
- Frequency Set by External Resistor: 200kHz to 3.5MHz
- Programmable Soft-Start
- Low V_{CESAT} Switch: 0.3V at 2.5A
- Capable of Positive and Negative Output Voltages (Boost, Inverting, SEPIC, Flyback)
- Available in Thermally Enhanced 20-Lead (4mm × 4mm) QFN and 20-Lead TSSOP Packages

APPLICATIONS

- High Power LED Driver
- DSL Modems
- Distributed Power
- Input/Output Current Limited Boost, SEPIC, Inverting, Flyback Converters
- CVCC Source

DESCRIPTION

The LT[®]3477 is a current mode, 3A DC/DC step-up converter with dual rail-to-rail current sense amplifiers and an internal 3A, 42V switch. It combines a traditional voltage feedback loop and two unique current feedback loops to operate as a constant-current, constant-voltage source. Both current sense voltages are set at 100mV and can be adjusted independently using the I_{ADJ1} and I_{ADJ2} pins. Efficiency of up to 91% can be achieved in typical applications. The LT3477 features a programmable soft-start function to limit inductor current during start-up. Both inputs of the error amplifier are available externally allowing positive and negative output voltages (Boost, Inverting, SEPIC, Flyback). The switching frequency is programmable from 200kHz to 3.5MHz through an external resistor.

Available in thermally enhanced 20-pin (4mm × 4mm) QFN and 20-pin TSSOP packages, the LT3477 provides a complete solution for both constant-voltage and constant-current applications.

LT, LTC and LT are registered trademarks of Linear Technology Corporation. All other trademarks are the property of their respective owners.

TYPICAL APPLICATION

330mA LED Driver with Open LED Protection

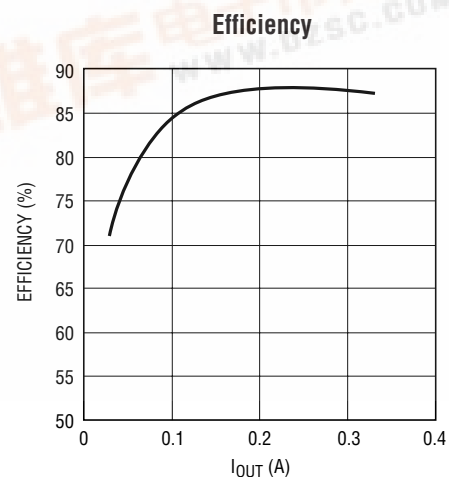
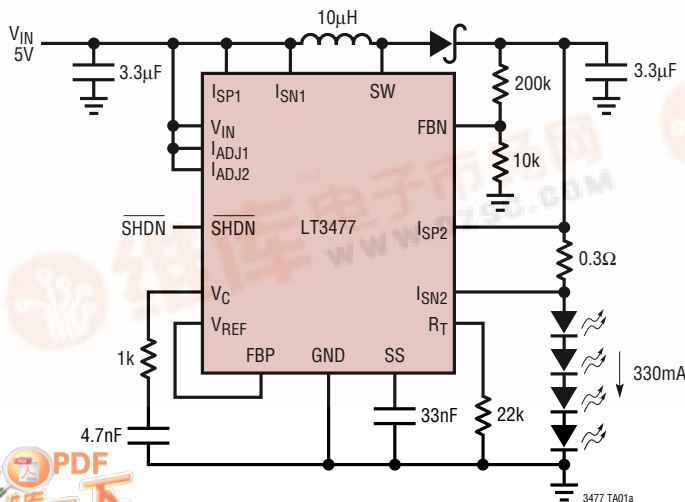

3477 TA01b

LT3477

ABSOLUTE MAXIMUM RATINGS (Note 1)

SW Pin Voltage	42V	I _{ADJ2} Pin Voltage	25V
V _{IN} Pin Voltage	25V	I _{SP1} , I _{SP2} Pin Voltage	42V
SHDN Pin Voltage	25V	I _{SN1} , I _{SN2} Pin Voltage	42V
FBP Pin Voltage	6V	Junction Temperature	125°C
FBN Pin Voltage	6V	Operating Temperature Range (Note 2) ..	-40°C to 85°C
V _{REF} Pin Voltage	6V	Storage Temperature Range	-65°C to 125°C
R _T Pin Voltage	6V	Lead Temperature (Soldering, 10 sec)	
V _C Pin Voltage	6V	TSSOP	300°C
I _{ADJ1} Pin Voltage	25V		

PACKAGE/ORDER INFORMATION

<p>TOP VIEW</p> <p>UF PACKAGE 20-LEAD (4mm × 4mm) PLASTIC QFN</p> <p>T_{JMAX} = 125°C, θ_{JA} = 37°C/W EXPOSED PAD (PIN 21) IS PGND (MUST BE SOLDERED TO PCB)</p>	ORDER PART NUMBER	<p>TOP VIEW</p> <p>FE PACKAGE 20-LEAD PLASTIC TSSOP</p> <p>T_{JMAX} = 150°C, θ_{JA} = 40°C/W EXPOSED PAD (PIN 21) IS PGND (MUST BE SOLDERED TO PCB)</p>	ORDER PART NUMBER
	LT3477EUF		LT3477EFE
	UF PART MARKING		
	3477		

Consult LTC Marketing for parts specified with wider operating temperature ranges.

ELECTRICAL CHARACTERISTICS

The ● indicates specifications which apply over the full operating temperature range, otherwise specifications are at T_A = 25°C. V_{IN} = 2.5V, V_{SHDN} = 2.5V.

PARAMETER	CONDITIONS	MIN	TYP	MAX	UNITS	
Minimum Input Voltage		●	2.3	2.5	V	
Quiescent Current	V _{IN} = 2.5V, V _{SHDN} = 0V V _{IN} = 2.5V, V _{SHDN} = 2.5V, V _C = 0.3V (Not Switching)		0.1 5.0	1.0 7.5	μA mA	
Reference Voltage		●	1.216	1.235	1.250	V
Reference Voltage Line Regulation	2.5V < V _{IN} < 25V, V _C = 0.3V		0.01	0.03	%/V	
Maximum V _{REF} Pin Current	Out of Pin			100	μA	
Soft-Start Pin Current	SS = 0.5V, Out of Pin		9		μA	
FBP Pin Bias Current			25	100	nA	
FBN Pin Bias Current			25	100	nA	
Feedback Amplifier Offset Voltage	FBP – FBN, V _C = 1V	-2	2	6	mV	
Feedback Amplifier Voltage Gain			500		V/V	

ELECTRICAL CHARACTERISTICS The ● indicates specifications which apply over the full operating temperature range, otherwise specifications are at $T_A = 25^\circ\text{C}$. $V_{IN} = 2.5\text{V}$, $V_{\overline{\text{SHDN}}} = 2.5\text{V}$.

PARAMETER	CONDITIONS	MIN	TYP	MAX	UNITS
Voltage Feedback Amplifier Transconductance			500		μS
Feedback Amplifier Sink Current	$V_{\text{FBP}} = 1.25\text{V}$, $V_{\text{FBN}} = 1.5\text{V}$, $V_C = 1\text{V}$		10		μA
Feedback Amplifier Source Current	$V_{\text{FBP}} = 1.25\text{V}$, $V_{\text{FBN}} = 1\text{V}$, $V_C = 0.5\text{V}$		10		μA
Current Sense Amplifier Sense Voltage	Positive Rail, $V_{\text{CM}} = 25\text{V}$ Ground	● 97.5 93.0	100 100	102.5 107.0	mV mV
Switching Frequency	$R_T = 17.2\text{k}$ $R_T = 107.4\text{k}$ $R_T = 2.44\text{k}$	0.9 160 2.7	1 200 3.5	1.15 240 4.3	MHz kHz MHz
Maximum Switch Duty Cycle	$R_T = 17.2\text{k}$	● 87	93		%
Switch Current Limit	(Note 3)	3	4	5	A
Switch V_{CESAT}	$I_{\text{SW}} = 1\text{A}$ (Note 3)		150	200	mV
Switch Leakage Current	$\text{SW} = 40\text{V}$		0.2	5	μA
SHDN Pin Current	$V_{\overline{\text{SHDN}}} = 5\text{V}$ $V_{\overline{\text{SHDN}}} = 0\text{V}$		30 0.1	60 1	μA μA
SHDN Pin Threshold		0.3	1.5	2	V

Note 1: Absolute Maximum Ratings are those values beyond which the life to the device may be impaired.

Note 2: The LT3477 is guaranteed to meet performance specifications from 0°C to 70°C . Specifications over the -40°C to 85°C operating

temperature range are assured by design, characterization and correlation with statistical process controls.

Note 3: Switch current limit and switch V_{CESAT} for UF package guaranteed by design and/or correlation to static test.

TYPICAL PERFORMANCE CHARACTERISTICS

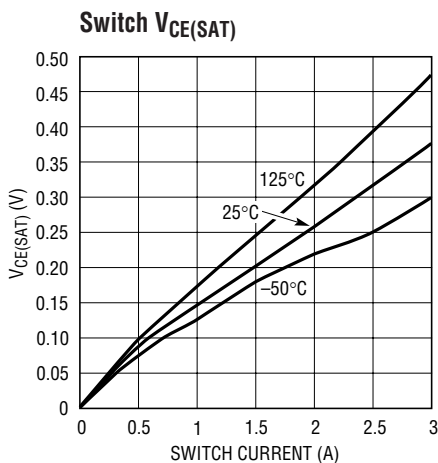

3477 G01

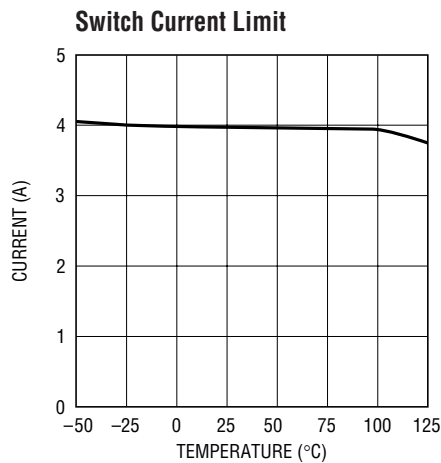

3477 G02

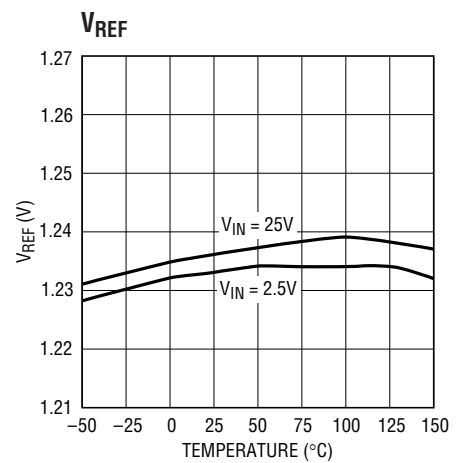

3477 G03

TYPICAL PERFORMANCE CHARACTERISTICS

SHDN Pin Turn-On Threshold

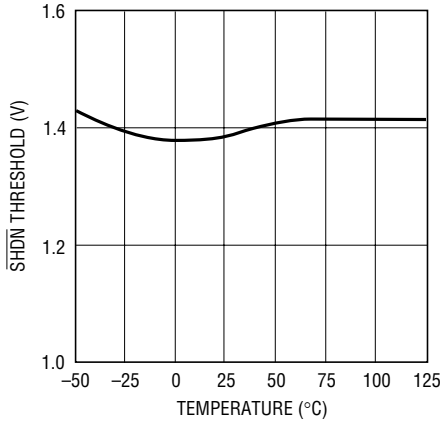

3477 G04

SHDN Pin Current

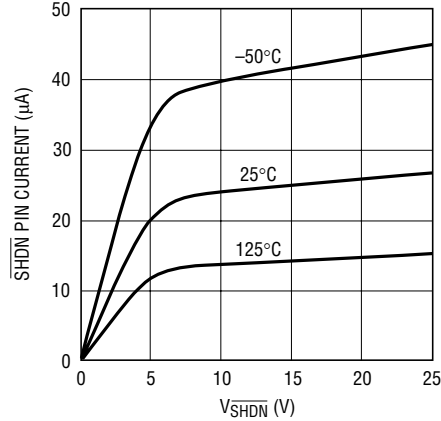

3477 G05

Quiescent Current

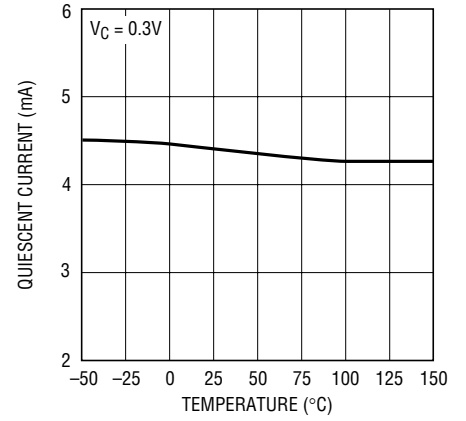

3477 G06

Soft-Start Pin Current

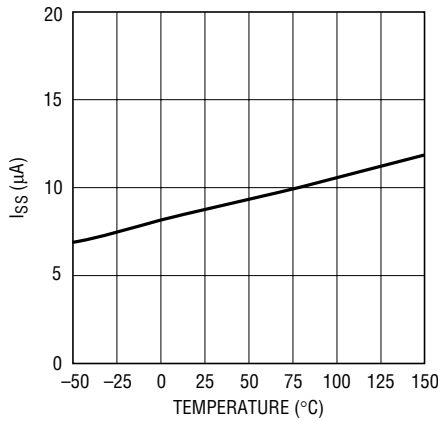

3477 G07

Oscillator Frequency

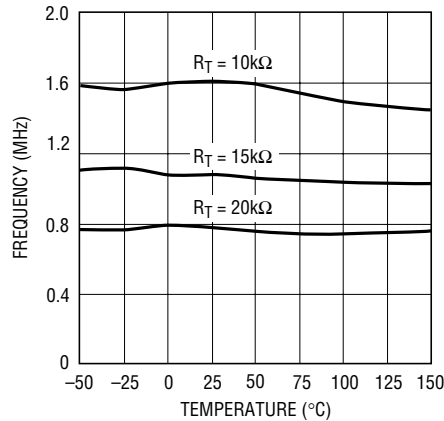

3477 G08

Feedback Amplifier Offset Voltage

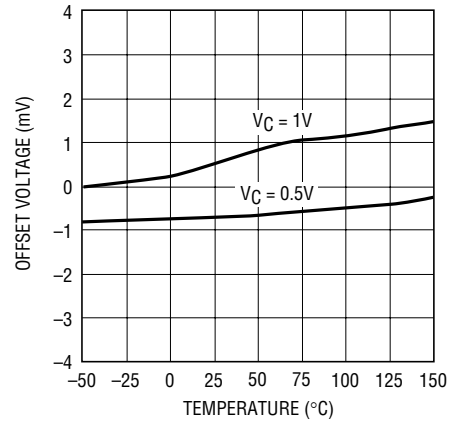

3477 G09

FBP Pin Bias Current

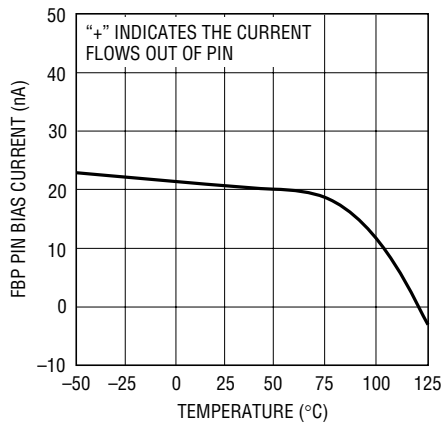

3477 G10

FBN Pin Bias Current

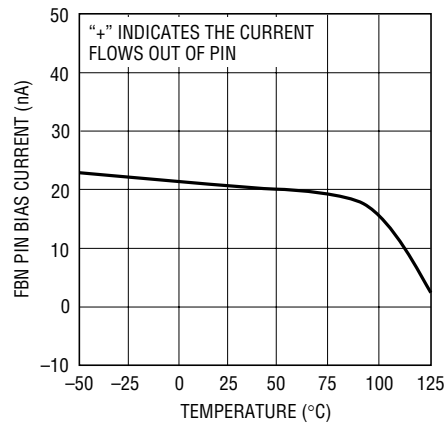

3477 G11

TYPICAL PERFORMANCE CHARACTERISTICS

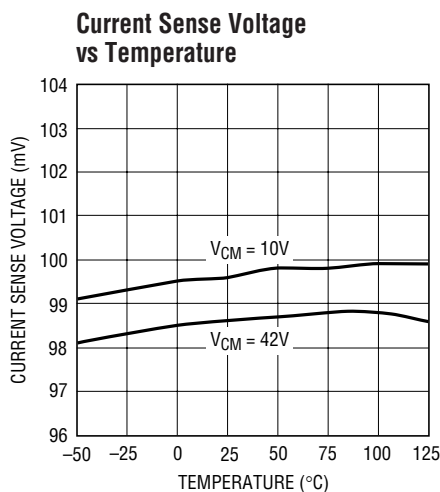

3477 G14

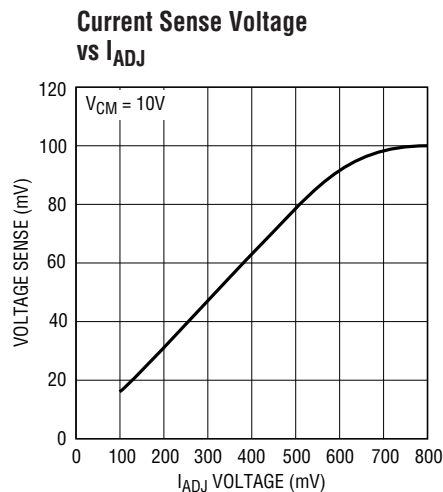

2477 G13

PIN FUNCTIONS (QFN/TSSOP)

NC (Pins 1, 2, 20/Pins 18, 19, 20): Connect to Ground.

V_{IN} (Pin 3/Pin 1): Input Supply. Must be locally bypassed. Powers the internal control circuitry.

R_T (Pin 4/Pin 2): Timing Resistor Pin. Adjusts the switching frequency. Connect a 17.2k resistor between R_T and GND for a 1MHz switching frequency. Do not leave this pin open. See Table 4 for additional R_T values and switching frequencies.

SHDN (Pin 5/Pin 3): Shutdown. Tie to 1.5V or greater to enable the device. Tie below 0.3V to turn off the device.

SS (Pin 6/Pin 4): Soft-Start. Place a soft-start capacitor here. Leave floating if not in use.

V_C (Pin 7/Pin 5): Compensation Pin for Error Amplifier. Connect a series RC from this pin to GND. Typical values are 1kΩ and 4.7nF.

FBN (Pin 8/Pin 6): The Inverting Input to the Error Amplifier. Connect resistive divider tap here for positive output voltage.

FBP (Pin 9/Pin 7): The Noninverting Input to the Error Amplifier. Connect resistive divider tap here for negative output voltage.

V_{REF} (Pin 10/Pin 8): Bandgap Voltage Reference. Internally set to 1.235V. Connect this pin to FBP if generating a positive output or to an external resistor divider if generating a negative voltage. This pin can provide up to 100μA of current and can be locally bypassed with a 100pF capacitor.

I_{ADJ2} (Pin 11/Pin 9): Second Current Sense Adjustment. Setting I_{ADJ2} to be less than 625mV leads to adjustment of the sensed voltage of the second current sense amplifier linearly. If I_{ADJ2} is tied to higher than 650mV, the default current sense voltage is 100mV. If current sense amplifier 2 is not used, always tie I_{ADJ2} to higher than 650mV.

I_{ADJ1} (Pin 12/Pin 10): First Current Sense Adjustment. Setting I_{ADJ1} to be less than 625mV leads to adjustment of the sensed voltage of the first current sense amplifier linearly. If I_{ADJ1} is tied to higher than 650mV, the default current sense voltage is 100mV. If current sense amplifier 1 is not used, always tie I_{ADJ1} to higher than 650mV.

I_{SP2} (Pin 13/Pin 11): Second Current Sense (+) Pin. The noninverting input to the second current sense amplifier.

PIN FUNCTIONS (QFN/TSSOP)

ISN2 (Pin 14/Pin 12): Second Current Sense (-) Pin. The inverting input to the second current sense amplifier.

ISP1 (Pin 15/Pin 13): First Current Sense (+) Pin. The noninverting input to the first current sense amplifier.

ISN1 (Pin 16/Pin 14): First Current Sense (-) Pin. The inverting input to the first current sense amplifier.

GND (Pins 17/Pin 15): Ground. Tie directly to local ground plane.

SW (Pins 18, 19/Pins 16, 17): Switch Pins. Collector of the internal NPN power switch. Connect the inductor and diode here and minimize the metal trace area connected to this pin to minimize electromagnetic interference.

Exposed Pad (Pin 21/Pin 21): Power Ground. Must be soldered to PCB ground for electrical contact and rated thermal performance.

BLOCK DIAGRAM

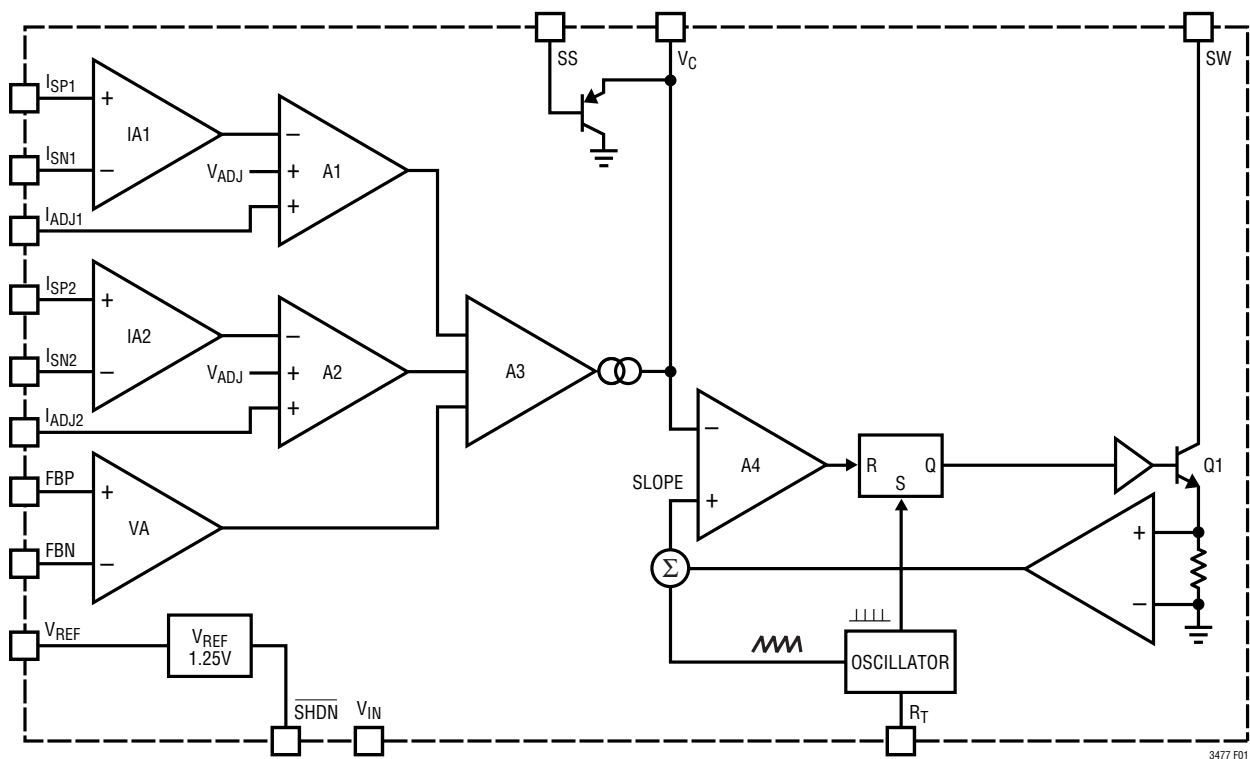

Figure 1. LT3477 Block Diagram

OPERATION

The LT3477 uses a fixed frequency, current mode control scheme to provide excellent line and load regulation. Operation can be best understood by referring to the Block Diagram in Figure 1. The start of each oscillator cycle sets the SR latch and turns on power switch Q1. The signal at the noninverting input of the PWM comparator (A4 SLOPE) is proportional to the sum of the switch current and oscillator ramp. When SLOPE exceeds V_C (the output of the feedback amplifier), the PWM comparator resets the latch and turns off the power switch. In this manner, the feedback amplifier and PWM comparators set the correct peak current level to keep the output in regulation. Amplifier A3 drives A4 inverting input. A3 has three inputs, one from the voltage feedback loop and the other two from the current feedback loop. Whichever feedback input is higher takes precedence, forcing the converter into either a constant-current or a constant-voltage mode. The LT3477 is designed to transition cleanly between the two modes of operation. Current sense amplifier IA1 senses the voltage between the I_{SP1} and I_{SN1} pins and provides a pre-gain to amplifier A1. When the voltage between I_{SP1} and I_{SN1} reaches 100mV, the output of IA1 provides V_{ADJ} to the inverting input of A1 and the converter is in constant-current mode. If the current sense voltage exceeds 100mV, the output of IA1 will increase causing the output of A3 to decrease, thus reducing the amount of current delivered to

the output. In this manner the current sense voltage is regulated to 100mV. The current sense level is also pin adjustable by I_{ADJ1} . Forcing I_{ADJ1} to less than 625mV will overwrite V_{ADJ} voltage that's set internally, thus providing current level control. The second current sense amplifier, IA2, works the same as the first current sense amplifier IA1. Both current sense amplifiers provide rail-to-rail current sense operation. Similarly, for positive output voltage operation where FBP is tied to V_{REF} , if the FBN pin increases above V_{REF} , the output of A3 will decrease to reduce the peak current level and regulate the output (constant-voltage mode). For negative output voltage operation where FBN is tied to GND, if the FBP pin decreases below GND level, the output of A3 will decrease to reduce the peak current level and regulate the output (constant-voltage mode).

The LT3477 also features a soft-start function. During start-up, 9 μ A of current charges the external soft-start capacitor. The SS pin directly limits the rate of voltage rise on the V_C pin, which in turn limits the peak switch current. The switch current is constantly monitored and not allowed to exceed the nominal value of 3A. If the switch current reaches 3A, the SR latch is reset regardless of the output of the PWM comparator. Current limit protects the power switch and external components.

APPLICATIONS INFORMATION

Capacitor Selection

Low ESR (equivalent series resistance) ceramic capacitors should be used at the output to minimize the output ripple voltage. Use only X5R or X7R dielectrics, as these materials retain their capacitance over wider voltage and temperature ranges better than other dielectrics. A 4.7 μ F to 10 μ F output capacitor is sufficient for most high output current designs. Converters with lower output currents may need only a 1 μ F or 2.2 μ F output capacitor.

Table 1. Ceramic Capacitor Manufacturers

MANUFACTURER	PHONE	WEB
Taiyo Yuden	(408) 573-4150	www.t-yuden.com
AVX	(803) 448-9411	www.avxcorp.com
Murata	(714) 852-2001	www.murata.com

Inductor Selection

Several inductors that work well with the LT3477 are listed in Table 2. However, there are many other manufacturers and devices that can be used. Consult each manufacturer for more detailed information and their entire range of parts. Ferrite core inductors should be used to obtain the best efficiency. Choose an inductor that can handle the necessary peak current without saturating, and ensure that the inductor has a low DCR (copper-wire resistance) to minimize I²R power losses. A 4.7 μ H or 10 μ H inductor will suffice for most LT3477 applications.

Inductor manufacturers specify the maximum current rating as the current where the inductance falls to some percentage of its nominal value—typically 65%. An

inductor can pass a current larger than its rated value without damaging it. Aggressive designs where board space is precious will exceed the maximum current rating of the inductor to save board space. Consult each manufacturer to determine how the maximum inductor current is measured and how much more current the inductor can reliably conduct.

Diode Selection

Schottky diodes, with their low forward voltage drop and fast switching speed, are ideal for LT3477 applications. Table 3 lists several Schottky diodes that work well with the LT3477. The diode’s average current rating must exceed the average output current. The diode’s maximum reverse voltage must exceed the output voltage. The diode conducts current only when the power switch is turned off (typically less than 50% duty cycle), so a 3A diode is sufficient for most designs. The companies below also offer Schottky diodes with higher voltage and current ratings.

Table 3. Suggested Diodes

MANUFACTURER PART NUMBER	MAX CURRENT (A)	MAX REVERSE VOLTAGE (V)	MANUFACTURER
UPS340	3	40	Microsemi www.microsemi.com
UPS315	3	15	
B220	2	20	Diodes, Inc www.diodes.com
B230	2	30	
B240	2	40	
B320	3	20	
B330	3	30	
B340	3	40	
SBM340	3	40	

Table 2. Suggested Inductors

MANUFACTURER PART NUMBER	I _{DC} (A)	INDUCTANCE (μ H)	MAX DCR (m Ω)	L \times W \times H (mm)	MANUFACTURER
CDRH6D283R0	3	3	24	6.7 \times 6.7 \times 3.0	Sumida www.sumida.com
CDRH6D28100	1.7	10	65	6.7 \times 6.7 \times 3.0	
CDRH4D284R7	1.32	4.7	72	5.0 \times 5.0 \times 3.0	
LM N 05D B4R7M	2.2	4.7	49	5.9 \times 6.1 \times 2.8	Taiyo Yuden www.t-yuden.com
LM N 05D B100K	1.6	10	10	5.9 \times 6.1 \times 2.8	
LQH55DN4R7M01L	2.7	4.7	57	5.7 \times 5.0 \times 4.7	Murata www.murata.com
LQH55DN100M01K	1.7	10	130	5.7 \times 5.0 \times 4.7	
FDV0630-4R7M	4.2	4.7	49	7.0 \times 7.7 \times 3.0	Toko www.toko.com

APPLICATIONS INFORMATION

Setting Positive Output Voltages

To set a positive output voltage, select the values of R1 and R2 (see Figure 2) according to the following equation:

$$V_{OUT} = 1.235V \left(1 + \frac{R1}{R2} \right)$$

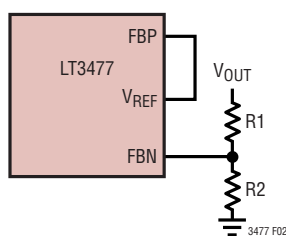

Figure 2. Positive Output Voltage Feedback Connections

Setting Negative Output Voltages

To set a negative output voltage, select the values of R3 and R4 (see Figure 3) according to the following equation:

$$V_{OUT} = -1.235V \left(\frac{R3}{R4} \right)$$

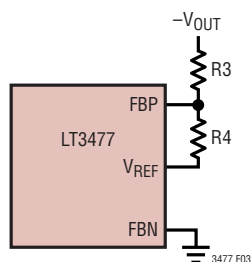

Figure 3. Negative Output Voltage Feedback Connections

Selecting R_{SENSE}/Current Sense Adjustment

Using the following formula to choose the correct current sense resistor value (for constant current or fail-safe operation).

$$R_{SENSE} = \frac{100mV}{I_{SENSE}}$$

For designs needing an adjustable current level, the I_{ADJ1} and I_{ADJ2} pins are provided for the first and the second current sense amplifiers, respectively. With the I_{ADJ1} and I_{ADJ2} pins tied higher than 800mV, the nominal current sense voltage is 100mV (appearing between the I_{SP1} and I_{SN2} or I_{SP2} and I_{SN2} pins). Applying a positive DC voltage less than 600mV to the I_{ADJ1} and I_{ADJ2} pins will decrease the current sense voltage according to the following formula:

$$I_{SENSE} = \frac{100mV}{R_{SENSE}} \cdot \frac{V_{IADJ}}{0.618V}$$

For example, if 309mV is applied to the I_{ADJ1} pin and R_{SENSE} is 0.5Ω, the current sense will be reduced from 200mA to 100mA. The adjustability allows the regulated current to be reduced without changing the current sense resistor (e.g., to adjust brightness in an LED driver or to reduce the charge current in a battery charger).

Considerations When Sensing Input Current

In addition to regulating the DC output current for current-source applications, the constant-current loop of the LT3477 can also be used to provide an accurate input current limit. Boost converters cannot provide output short-circuit protection, but the surge turn-on current can be drastically reduced using the LT3477 current sense at the input. SEPICs, however, have an output that is DC-isolated from the input, so an input current limit not only helps soft-start the output but also provides excellent short-circuit protection.

When sensing input current, the sense resistor should be placed in front of the inductor (between the decoupling capacitor and the inductor). This will regulate the average inductor current and maintain a consistent inductor ripple current, which will, in turn, maintain a well regulated input current. Do not place the sense resistor between the input source and the input decoupling capacitor, as this may allow the inductor ripple current to vary widely (even though the average input current and the average inductor current will still be regulated). Since the inductor current

APPLICATIONS INFORMATION

is a triangular waveform (not a DC waveform like the output current) some tweaking of the compensation values (R_C and C_C on the V_C pin) may be required to ensure a clean inductor ripple current while the constant-current loop is in effect. For these applications, the constant-current loop response can usually be improved by reducing the R_C value or by adding a capacitor (with a value of approximately $C_C/10$) in parallel with the R_C and C_C compensation network.

Frequency Compensation

The LT3477 has an external compensation pin (V_C), which allows the loop response to be optimized for each application. An external resistor and capacitor (or sometimes just a capacitor) are placed at the V_C pin to provide a pole and a zero (or just a pole) to ensure proper loop compensation. Several other poles and zeroes are present in the closed-loop transfer function of a switching regulator, so the V_C pin pole and zero are positioned to provide the best loop response. A thorough analysis of the switching regulator control loop is not within the scope of this data sheet, and will not be presented here, but values of 1k and 4.7nF will be a good choice for many designs. For those wishing to optimize the compensation, use the 1k and 4.7nF as a starting point.

Board Layout

As with all switching regulators, careful attention must be paid to the PCB board layout and component placement. To maximize efficiency, switch rise and fall times are made as short as possible. To prevent radiation and high frequency resonance problems, proper layout of the high frequency switching path is essential. Minimize the length and area of all traces connected to the SW pin and always use a ground plane under the switching regulator to minimize interplane coupling. The signal path including the switch, output diode D1 and output capacitor C_{OUT} , contains nanosecond rise and fall times and should be kept as short as possible.

Soft-Start

For many applications, it is necessary to minimize the inrush current at start-up. The built-in soft-start circuit significantly reduces the start-up current spike and output voltage overshoot. A typical value for the soft-start capacitor is 10nF.

Switching Frequency

The switching frequency of the LT3477 is set by an external resistor attached to the R_T pin. Do not leave this pin open. A resistor must always be connected for proper operation. See Table 4 and Figure 4 for resistor values and corresponding frequencies.

Increasing switching frequency reduces output voltage ripple but also reduces efficiency. The user should set the frequency for the maximum tolerable output voltage ripple.

Table 4. Switching Frequency

SWITCHING FREQUENCY (MHz)	R_T (k Ω)
3.5	2.44
3	3.62
2.5	4.89
2	6.77
1.5	10.2
1	17.2
0.5	43.2
0.2	107.4

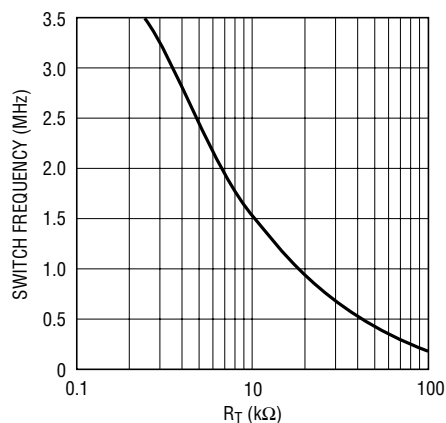

3477 F04

Figure 5. Switch Frequency

TYPICAL APPLICATIONS

5.5V SEPIC Converter with Short-Circuit Capability

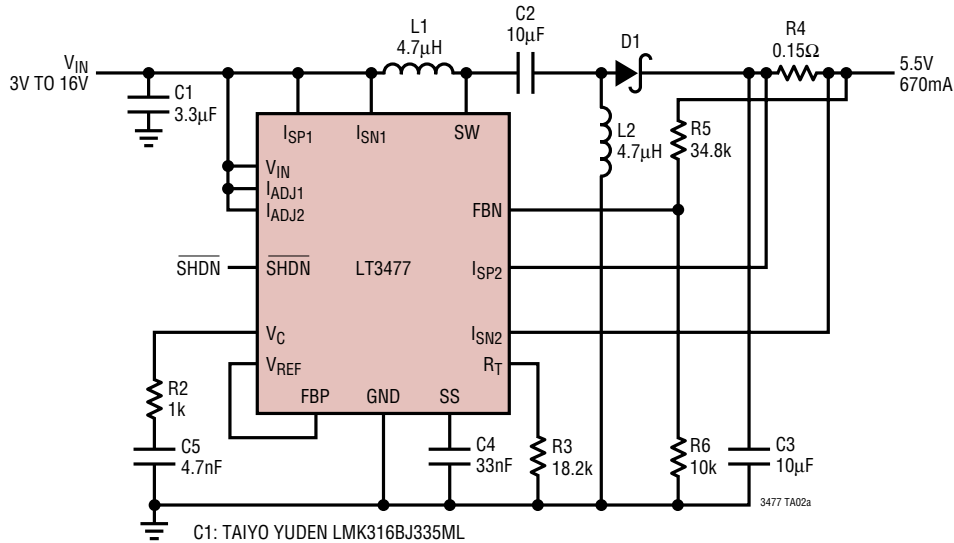

- C1: TAIYO YUDEN LMK316BJ335ML
- C2: TAIYO YUDEN LMK325BJ106MN
- C3: TAIYO YUDEN LMK316BJ106ZL
- D1: DIODES INC. DFL5120L
- L1, L2: TOKO FDV0630-4R7M

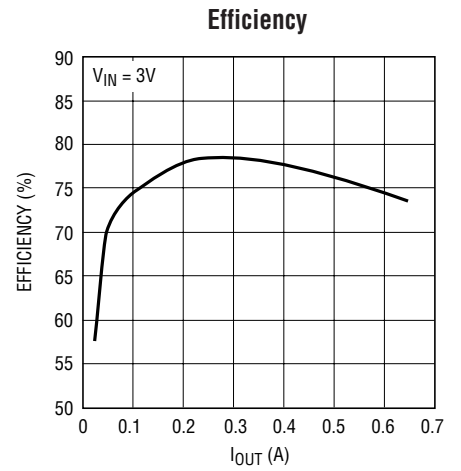

800mA, 5V to 12V Boost Converter

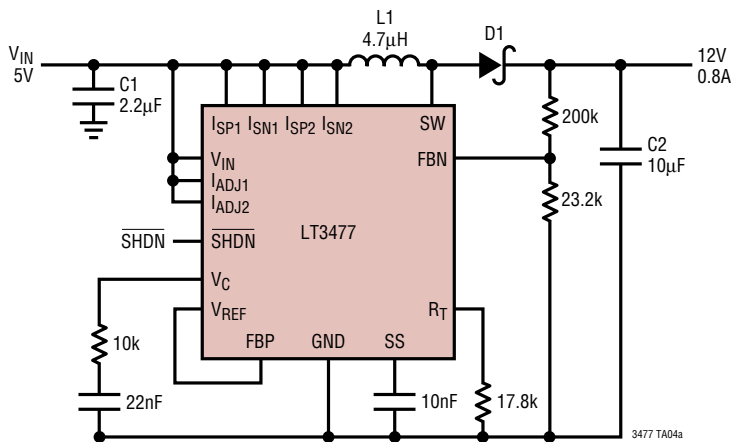

- C1: TAIYO YUDEN LMK316BJ225MD
- C2: AVX 1206YD106MAT
- D1: DIODES INC. B320A
- L1: TOKO FDV0630-4R7M

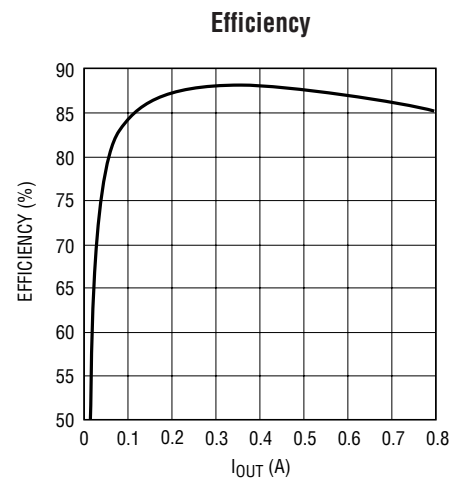

LT3477

TYPICAL APPLICATIONS

88% Efficient, 4W LED Driver

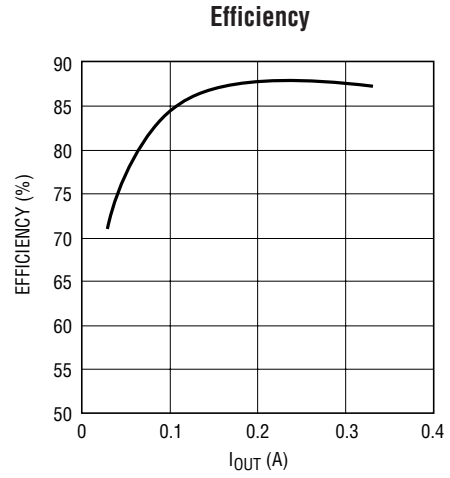
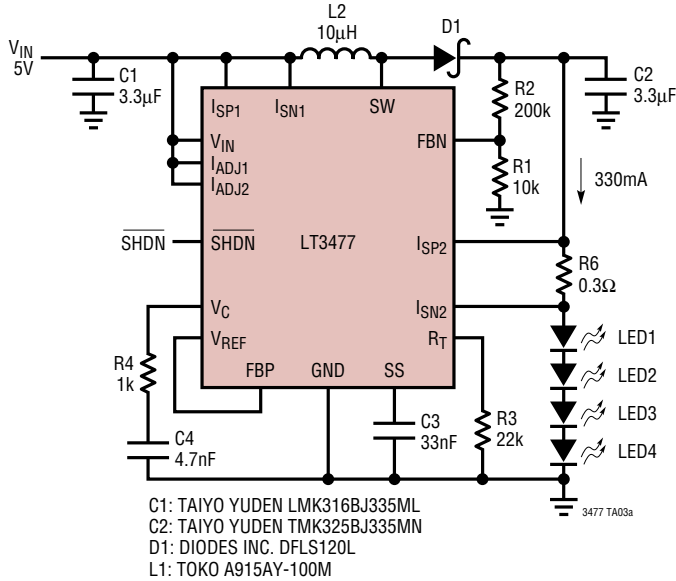

3477 TA01b

1A Buck Mode High Current LED Driver

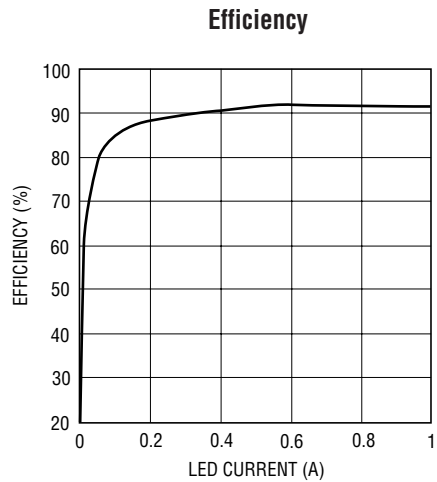
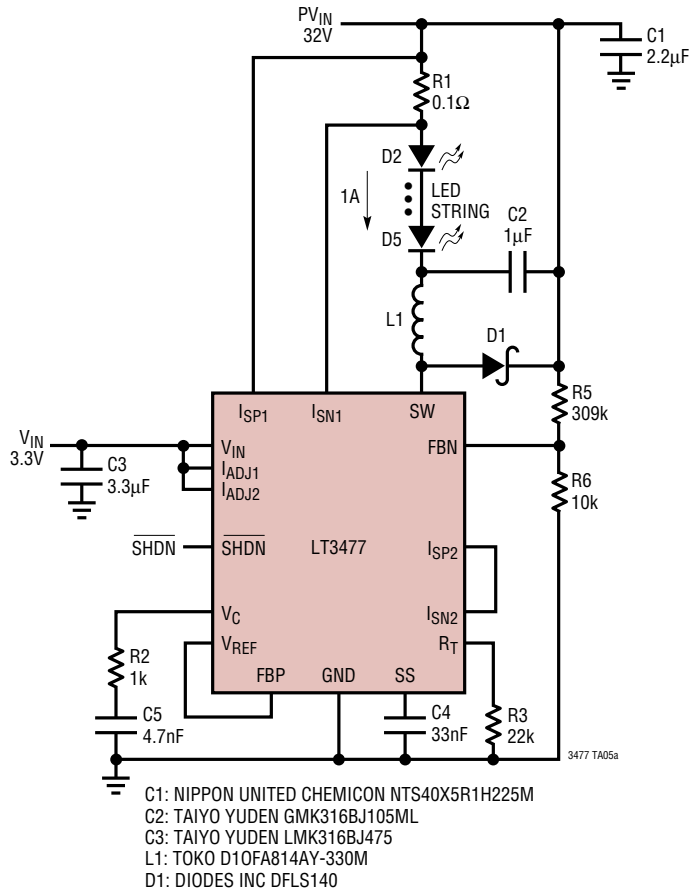

3477 TA05b

TYPICAL APPLICATIONS

Buck-Boost LED Driver

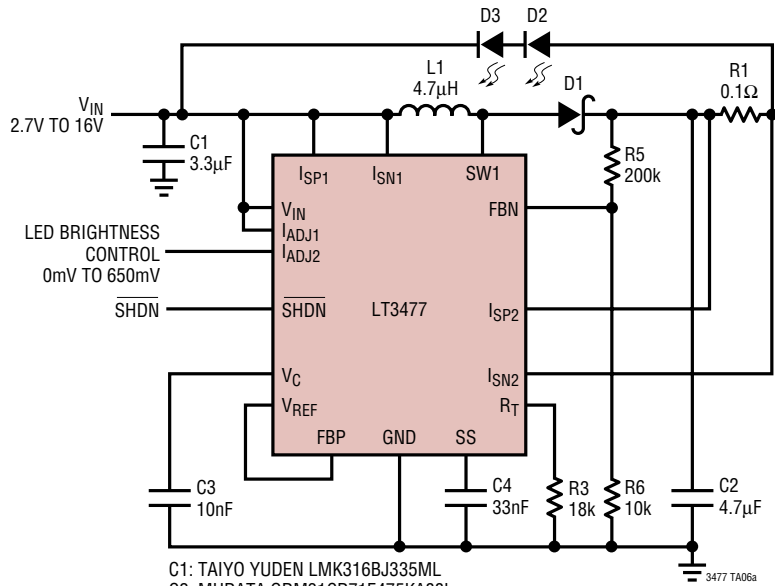

- C1: TAIYO YUDEN LMK316BJ335ML
- C2: MURATA GRM31CR71E475KA88L
- D1: DIODES, INC. B320A
- L1: TOKO FDV0630-4R7M

Efficiency

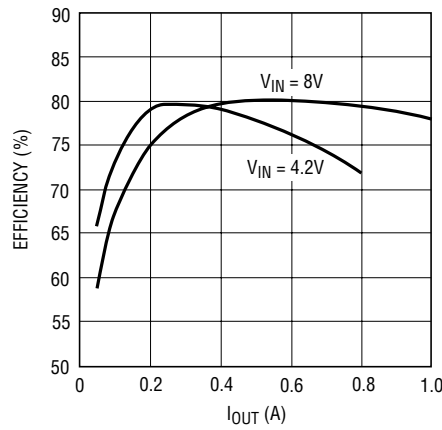

3477 TA06b

PACKAGE DESCRIPTION

UF Package
20-Lead Plastic QFN (4mm × 4mm)
 (Reference LTC DWG # 05-08-1710)

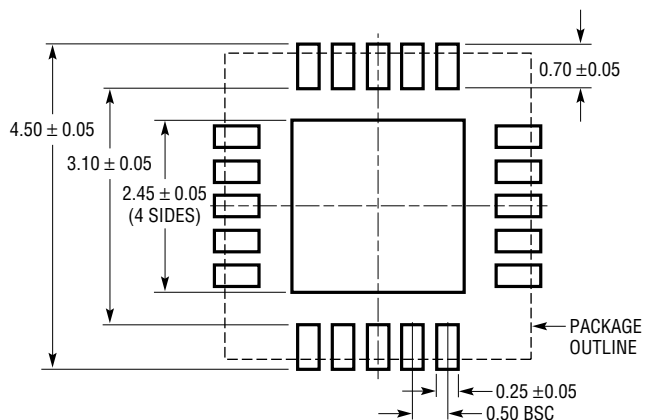

RECOMMENDED SOLDER PAD PITCH AND DIMENSIONS

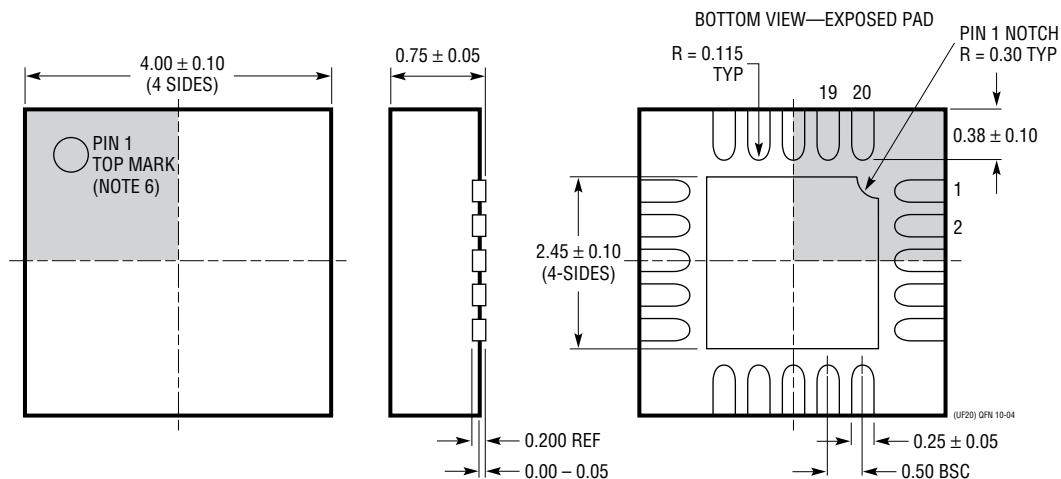

- NOTE:
1. DRAWING IS PROPOSED TO BE MADE A JEDEC PACKAGE OUTLINE MO-220 VARIATION (WGGD-1)—TO BE APPROVED
 2. DRAWING NOT TO SCALE
 3. ALL DIMENSIONS ARE IN MILLIMETERS
 4. DIMENSIONS OF EXPOSED PAD ON BOTTOM OF PACKAGE DO NOT INCLUDE MOLD FLASH. MOLD FLASH, IF PRESENT, SHALL NOT EXCEED 0.15mm ON ANY SIDE
 5. EXPOSED PAD SHALL BE SOLDER PLATED
 6. SHADED AREA IS ONLY A REFERENCE FOR PIN 1 LOCATION ON THE TOP AND BOTTOM OF PACKAGE

PACKAGE DESCRIPTION

FE Package
20-Lead Plastic TSSOP (4.4mm)
 (Reference LTC DWG # 05-08-1663)
Exposed Pad Variation CB

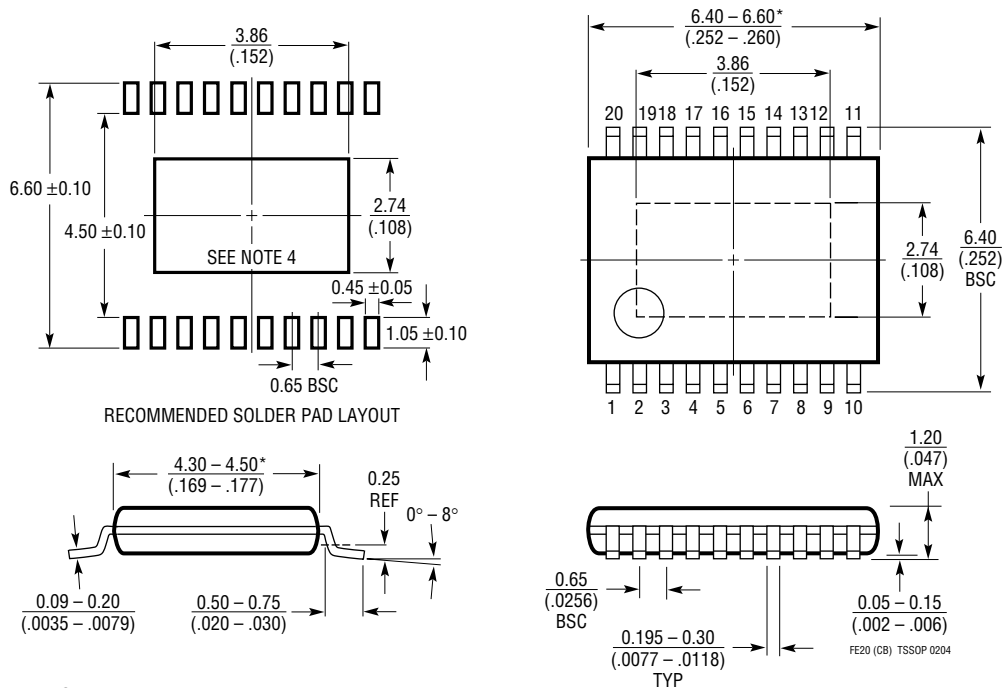

NOTE:

1. CONTROLLING DIMENSION: MILLIMETERS
 2. DIMENSIONS ARE IN $\frac{\text{MILLIMETERS}}{\text{(INCHES)}}$
 3. DRAWING NOT TO SCALE
 4. RECOMMENDED MINIMUM PCB METAL SIZE FOR EXPOSED PAD ATTACHMENT
- *DIMENSIONS DO NOT INCLUDE MOLD FLASH. MOLD FLASH SHALL NOT EXCEED 0.150mm (.006") PER SIDE

LT3477

TYPICAL APPLICATION

Buck Mode High Current LED Driver

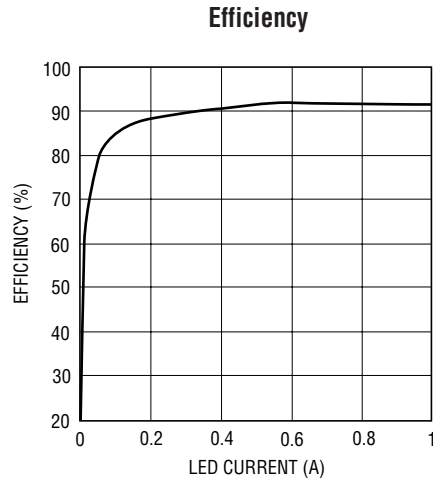
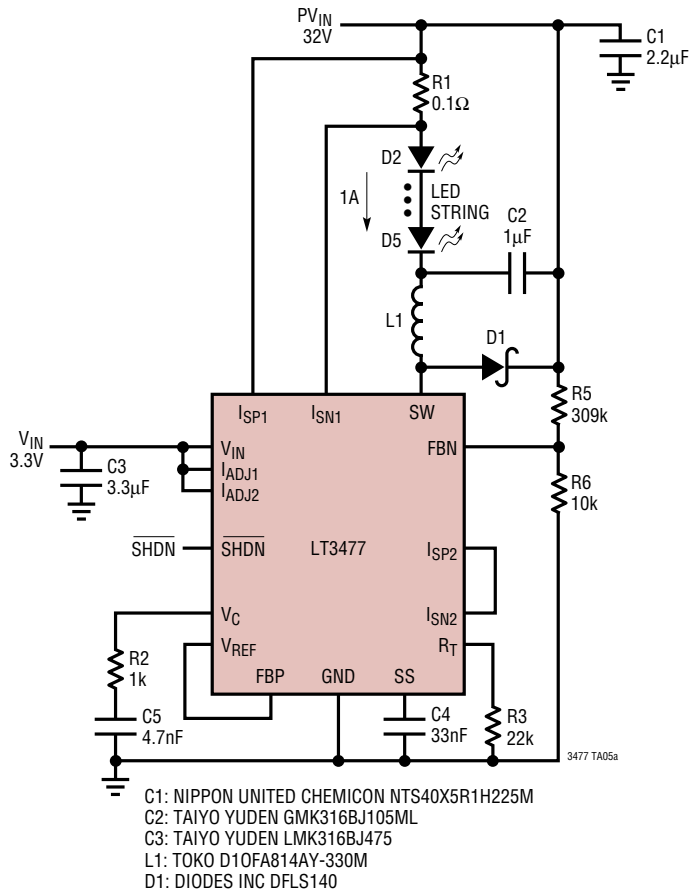

3477 TA05b

RELATED PARTS

PART NUMBER	DESCRIPTION	COMMENTS
LT1618	Constant Current, Constant Voltage 1.4MHz, High Efficiency Boost Regulator	V_{IN} : 1.6V to 18V, $V_{OUT(MAX)}$ = 5.5V, I_Q = 2.5mA, I_{SD} < 1μA, QFN16 Package
LT3436	3A (I_{SW}), 1MHz, 34V Step-Up DC/DC Converter	V_{IN} : 3V to 25V, $V_{OUT(MAX)}$ = 34V, I_Q = 0.9mA, I_{SD} < 6μA, TSSOP16E Package
LTC [®] 3453	Synchronous Buck-Boost High Power White LED Driver	V_{IN} : 2.7V to 5.5V, $V_{OUT(MAX)}$ = 5.5V, I_Q = 2.5mA, I_{SD} < 1μA, QFN16 Package
LT3466	Dual Constant Current, 2MHz, High Efficiency White LED Boost Regulator with Integrated Schottky Diode	V_{IN} : 2.7V to 24V, $V_{OUT(MAX)}$ = 40V, I_Q = 5mA, I_{SD} < 16μA, DFN Package
LT3479	3A, 42V Full Featured Boost/Inverter Converter with Soft-Start	V_{IN} : 2.5V to 24V, $V_{OUT(MAX)}$ = 40V, I_Q = 5mA, I_{SD} < 1μA, DFN/TSSOP Packages
LTC3490	Single Cell 350mA, 1.3MHz LED Driver	V_{IN} : 1V to 3.2V, $V_{OUT(MAX)}$ = 4.7V, I_{SD} < 1μA, DFN/SO8 Packages