



A Collection of Differential to Single-Ended Signal Conditioning Circuits for Use with the LTC2400, a 24-Bit No Latency $\Delta\Sigma$ ADC in an SO-8

By Kevin R. Hoskins and Derek V. Redmayne

INTRODUCTION

The LTC[®]2400 is the industry's first No Latency $\Delta\Sigma$ [™] ADC that combines automatic offset and full-scale calibration, an internal oscillator, a sinc⁴ digital filter, and serial I/O to yield a 24-bit ADC with 1.5 μ V_{RMS} input noise and single-shot conversion time architecture. It is the ideal A/D converter for temperature measurement and high effective resolution instrumentation applications, such as digital multimeters.

This application note contains six circuits that extend the LTC2400's capabilities using a number of low

power differential-to-single-ended signal conditioning circuits. These circuits offer the customer a number of choices for conditioning differential input signals as low as 5mV to as high as ± 2.5 V, as well as operation on a single 5V or ± 5 V supplies. In each case, careful circuit design and implementation techniques were used to maintain or preserve the LTC2400's inherently high effective resolution. In some cases, circuit accuracies (uncalibrated) exceed 17 bits.

LTC, LTC and LT are registered trademarks of Linear Technology Corporation. No Latency $\Delta\Sigma$ is a trademark of Linear Technology Corporation.

TABLE OF CONTENTS

Circuit 1. LTC2400 High Accuracy Differential to Single-Ended Converter for 5V Supplies	AN78-2
<i>Differential to Single-Ended Converter Has Very High Uncalibrated Accuracy and Low Offset and Drift</i>	
Circuit 2. Simple Differential Front-End for the LTC2400	AN78-4
<i>Simple Rail-to-Rail Circuit Converts Differential Signals to Single-Ended Signals and Operates on Single or Dual Supplies Where Resolution Is More Important Than Accuracy</i>	
Circuit 3. Bipolar Input 24-Bit A/D Converter Accepts ± 2.5 V Inputs	AN78-6
<i>Differential Input 24-Bit A/D Converter Provides Half-Scale Zero for Bipolar Input Signals</i>	
Circuit 4. High Accuracy, Differential to Single-Ended Conversion for Wide Range Bipolar Input Signals	AN78-8
<i>Bipolar Differential to Single-Ended Converter Drives the LTC2400's Input Rail-to-Rail</i>	
Circuit 5. Low Level, High Accuracy, Bipolar Input Differential to Single-Ended Signal Conversion for 24-Bit A/D	AN78-10
<i>Single Supply Differential to Single-Ended Conversion Circuit Amplifies Low Level Bipolar Signals and Maintains the LTC2400's High Accuracy</i>	
Circuit 6. LTC2400 High Accuracy Differential to Single-Ended Converter for Single 5V Supply	AN78-12
<i>This Converter Has High Accuracy, Very Low Offset and Offset Drift, Rail-to-Rail Input Common Mode Range and is "Live at Zero"</i>	
LTC2400 Bonus Circuits	
#1: An Extremely High Resolution LTC2400-P _t RTD Temperature Digitizer	AN78-14
#2: A High Resolution LTC2400-Based Type S Thermocouple Temperature Digitizer	AN78-15
LTC2400 Key Specifications Summary	AN78-16



Application Note 78

Circuit 1 LTC2400 High Accuracy Differential to Single-Ended Converter for $\pm 5V$ Supplies

Differential to Single-Ended Converter Has Very High Uncalibrated Accuracy and Low Offset and Drift

SPECIFICATIONS

$V_{CC} = V_{REF} = LT^{\circ}1236-5$; $V_{FS} = 40mV$;
 $R_{SOURCE} = 175\Omega$ (Balanced)

PARAMETER	CIRCUIT (MEASURED)	LTC2400	TOTAL (UNITS)
Input Voltage Range	-3 to 40		mV
Zero Error	12.7	1.5	μV
Input Current	See Text		
Nonlinearity	± 1	4	ppm
Input-Referred Noise (without averaging)	0.3*	1.5	μV_{RMS}
Input-Referred Noise (averaged 64 readings)	0.05*		μV_{RMS}
Resolution (with averaged readings)	19.6		Bits
Overall Accuracy (uncalibrated**)	18.1		Bits
Supply Voltage	± 5	5	V
Supply Current	1.6	0.2	mA
CMRR	120		dB
Common Mode Range	± 5		V

* Input-referred noise with a gain of 101.

** Does not include gain setting resistors.

OPERATION

The circuit in Figure 1 is ideal for low level differential signals in applications that have a $\pm 5V$ supply and need high accuracy without calibration. The circuit combines an LTC 1043 and LTC1050 as a differential to single-ended amplifier that has an input common mode range that includes the power supplies. It uses the LTC1043 to sample a differential input voltage, holds it on C_S and transfers it to a ground-referred capacitor, C_H . The voltage on C_H is applied to the LTC1050's noninverting input and amplified by the gain set by resistors R1 and R2 (101 for the values shown). The amplifier's output is then converted to a digital value by the LTC2400.

The LTC1043 achieves its best differential to single-ended conversion when its internal switching frequency operates at a nominal 300Hz, as set by the $0.01\mu F$ capacitor C1 and when $1\mu F$ capacitors are used for C_S and C_H . C_S and C_H should be a film type such as mylar or polypropylene. Conversion accuracy is enhanced by placing a guard shield around C_S and connecting the shield to Pin 10 of the LTC1043. This minimizes nonlinearity that results from stray capacitance transfer errors associated with C_S . To minimize the possibility of PCB leakage currents introducing an error source into C_H , an optional guard circuit could be added as shown. The common point of these two resistors produces the potential for the guard ring. Consult the LTC1043 data sheet for more information. As is good practice in all high precision circuits, keep all lead lengths as short as possible to minimize stray capacitance and noise pickup.

The LTC1050's closed-loop gain accuracy is affected by the tolerance of the ratio of the gain-setting resistors. If cost considerations preclude using low tolerance resistors (0.02% or better), the processor to which the LTC2400 is connected can be used to perform software correction. Operated as a follower, the LTC1050's gain and linearity error is less than 0.001%.

As stated above, the LTC1043 has the highest transfer accuracy when using $1.0\mu F$ capacitors. For example, $0.1\mu F$ will typically increase the circuit's overall nonlinearity tenfold.

Another source of errors is thermocouple effects that occur in soldered connections. Their effects are most pronounced in the circuit's low level portion, before the LTC1050's output. Any temperature changes in any of the low level circuitry's connections will cause linearity perturbations in the final conversion result. Their effects can be minimized by balancing the thermocouple connections

Application Note 78

with reversed redundant connections and by sealing the circuit against moving air.

A subtle source of error arises from ground lead impedance differences between the LTC1043 circuit, the LTC1050 preamplifier and the LTC2400. This error can be avoided by connecting Pin 14 of the LTC1043, the bottom end of R2 and Pin 4 of the LTC2400 to a single-point “star” ground.

The circuit’s input current is dependent on the input signal’s common mode voltage. The input current is approximately -100nA at $V_{IN(CM)} = -5\text{V}$, 100nA at $V_{IN(CM)} = 5\text{V}$ and $0\mu\text{A}$ at $V_{IN(CM)} = 0\text{V}$. The values may vary from

part to part. Figure 1’s input is analogous to a $2\mu\text{F}$ capacitor in parallel with a $25\text{M}\Omega$ connected to ground. The LTC1043’s nominal 800Ω switch resistance is between the source and the $2\mu\text{F}$ capacitance.

The circuit schematic shows an optional resistor, R_S . This resistor can be placed in series with the LTC2400’s input to limit current if the input goes below -300mV . The resistor does not degrade the converter’s performance as long as any capacitance, stray or otherwise, connected between the LTC2400’s input and ground is less than 100pF . Higher capacitance will increase offset and fullscale errors.

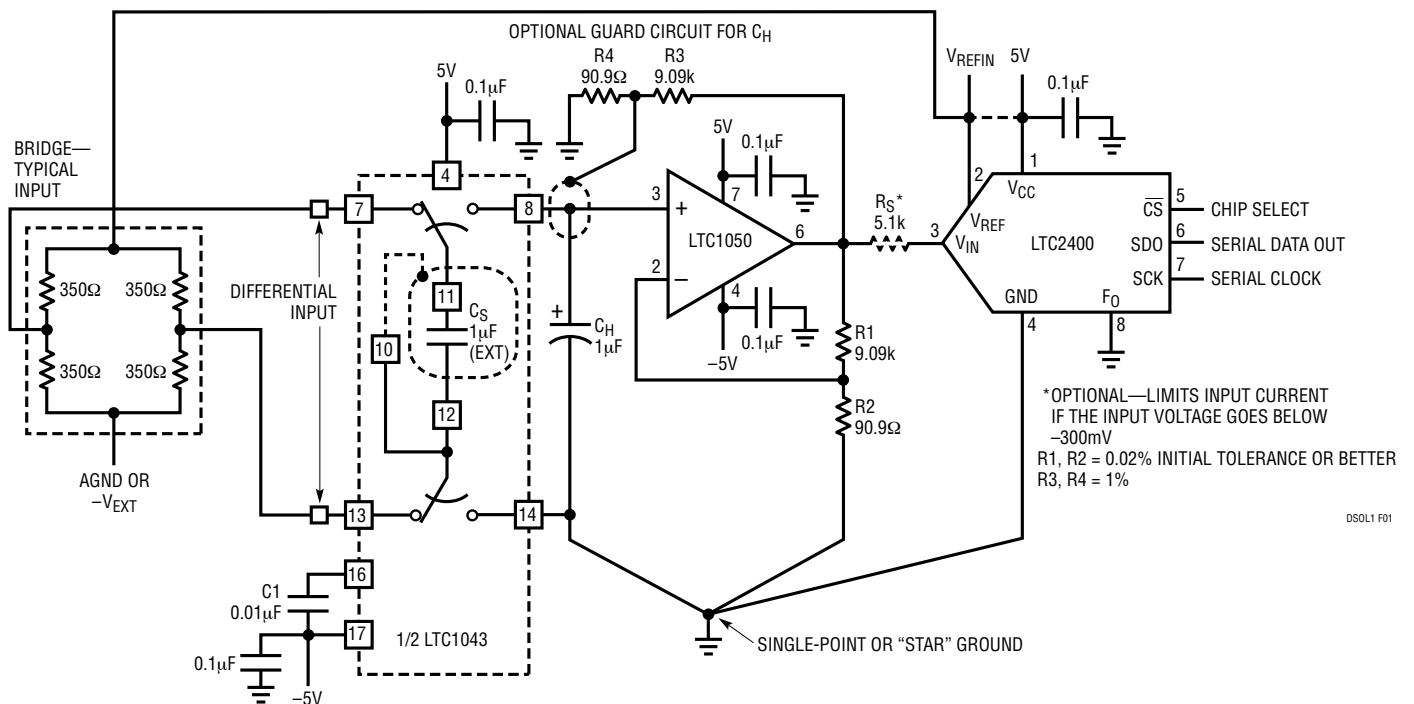

Figure 1. Differential to Single-Ended Converter for Low Level Inputs, Such as Bridges, Maintains the LTC2400’s High Accuracy

Application Note 78

Circuit 2

Simple Differential Front-End for the LTC2400

Simple Rail-to-Rail Circuit Converts Differential Signals to Single-Ended Signals and Operates on Single or Dual Supplies Where Resolution Is More Important Than Accuracy

SPECIFICATIONS

$V_{CC} = V_{REF} = LT^{\circ}1236-5$; $V_{FS} = 5V$; $R_{SOURCE} = 175\Omega$ (Balanced)

PARAMETER	CIRCUIT (MEASURED)	LTC2400	TOTAL (UNITS)
Input Voltage Range	-0.3 to 5.3		V
Zero Error	2.75		mV
Input Current	See Text		
Nonlinearity	± 35	4	ppm
Input-Referred Noise (without averaging)	10	1.5	μV_{RMS}
Input-Referred Noise (averaged 64 readings)	1.5		μV_{RMS}
Resolution (with averaged readings)	21.7		Bits
Supply Voltage	5	5	V
Supply Current	0.45	0.2	mA
CMRR	118		dB
Common Mode Range*	-5 to 5		V

*0V to 5V for single 5V supply

OPERATION

The circuit in Figure 2 is ideal for wide dynamic range differential signals in applications that have a 5V or $\pm 5V$ supply where absolute accuracy is secondary to high resolution. The circuit uses one-half of an LTC[®]1043 to perform a differential to single-ended conversion over an input common mode range that includes the power supplies. It uses the LTC1043 to sample a differential input voltage, holds it on C_S and transfers it to a ground-referred capacitor C_H . The voltage on C_H is applied to the LTC2400's input and converted to a digital value.

The LTC1043 achieves its best differential to single-ended conversion when its internal switching frequency operates at a nominal 300Hz, as set by the 0.01 μF capacitor C1 and when 1 μF capacitors are used for C_S and C_H . C_S and C_H should be a film type such as mylar or polypropylene.

Conversion accuracy is enhanced by placing a guard shield around C_S and connecting the shield to Pin 10 of the LTC1043. This minimizes nonlinearity that results from stray capacitance transfer errors associated with C_S . Consult the LTC1043 data sheet for more information. As is good practice in all high precision circuits, keep all lead lengths as short as possible to minimize stray capacitance and noise pickup.

Like all delta-sigma converters, the LTC2400's input circuitry causes small current spikes on the input signal. These current spikes perturb the voltage on the LTC1043's C_H , which results in an effective increase in offset voltage and gain error. These errors remain constant and can be removed through software. Without this end-point correction that reduces the effects of zero and full-scale error, the overall accuracy is degraded. The input dynamic range, however, is not compromised and the overall linearity remains at ± 35 ppm, or 14.5bits.

For inputs with common mode voltages that swing above and below ground, connect Pin 17 to a negative supply, as shown in Figure 2. When applying differential voltages with common mode voltages between ground and the LTC1043's positive supply, connect Pin 17 (V^-) to ground for single supply operation.

As stated above, the LTC1043 has the highest transfer accuracy when using 1 μF capacitors. Using any other value will compromise the accuracy. For example, 0.1 μF will typically increase the circuit's overall nonlinearity and decrease the CMRR by a factor of 10.

The LTC1043's internal oscillator's frequency will vary with changes in supply voltage. This variation shows up as increased noise and/or gain error. For example, a 100mV change in the LTC1043's supply voltage causes 14ppm gain error in the LTC2400. If this variation is short term,

this error appears as noise. The LTC1043 shows the largest gain error at a nominal common mode input of 3V. These errors can be reduced by using an external clock. As the LTC1043's V_{CC} increases from a nominal 5V, gain errors are most significant and below 5V, linearity errors become more significant.

The circuit's input current is dependent on the input signal's magnitude and the reference voltage. For a 5V reference, the input current is approximately $-1\mu\text{A}$ at zero

scale, $1\mu\text{A}$ at full scale and $0\mu\text{A}$ at midscale. The values may vary from part to part. Figure 2's input is analogous to a $2\mu\text{F}$ capacitor in parallel with a $2.5\text{M}\Omega$ connected to $V_{REF}/2$. The LTC1043's nominal 800Ω switch resistance is between the source and the $2\mu\text{F}$ capacitance. This description applies to cases where a capacitor is connected in parallel to the LTC2400's input.

This circuit is best suited to applications with large signal swings, and source impedances under 500Ω .

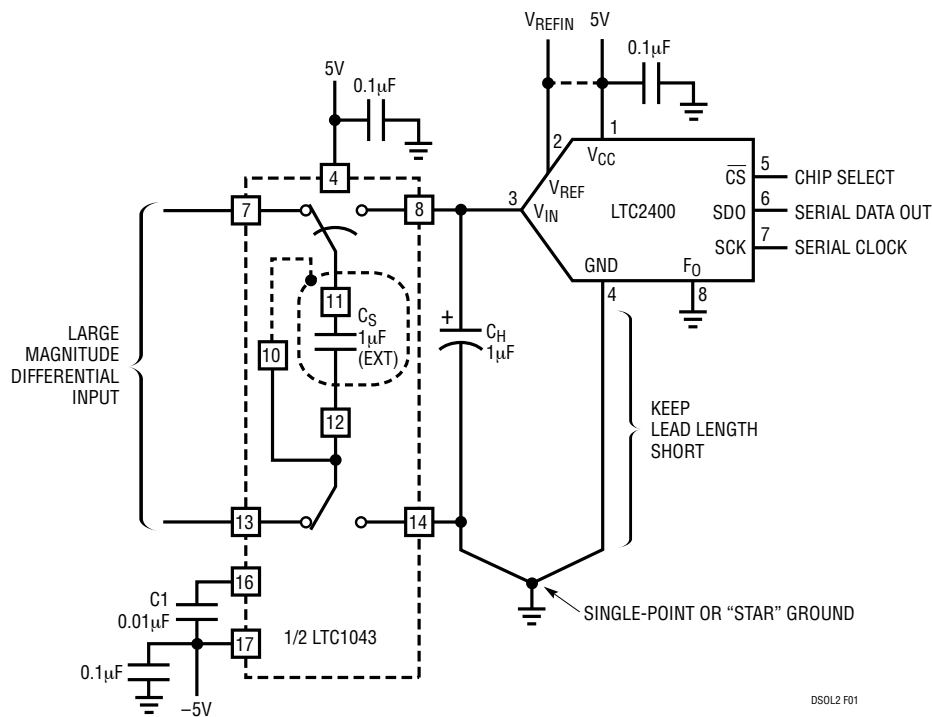

Figure 2. Simple Rail-to-Rail Circuit Converts Differential Signals to Single-Ended Signals

Application Note 78

Circuit 3

Bipolar Input 24-Bit A/D Converter Accepts $\pm 2.5V$ Inputs

Differential Input 24-Bit A/D Converter Provides Half-Scale Zero for Bipolar Input Signals

SPECIFICATIONS

$V_{CC} = V_{REF} = \text{LT1236-5}$; $V_{FS} = \pm 2.5V$;
 $R_{SOURCE} = 175\Omega$ (Balanced)

PARAMETER	CIRCUIT (MEASURED)	LTC2400	TOTAL (UNITS)
Input Voltage Range	± 2.8		V
Zero Error	70	1.5	μV
Input Current	See Text		
Nonlinearity	± 35	4	ppm
Input-Referred Noise (without averaging)	10	1.5	μV_{RMS}
Input Referred Noise (averaged 64 readings)	1.5		μV_{RMS}
Resolution (with averaged readings)	21.7		Bits
Supply Voltage	5	5	V
Supply Current	0.5	0.2	mA
CMRR	118		dB
Common Mode Range	0 to 5		V

OPERATION

The circuit in Figure 3 is ideal for wide dynamic range differential signals in applications that have a 5V supply. The circuit uses one-half of an LTC1043 to perform a differential to single-ended conversion over an input common mode range that includes the power supplies. This half of the LTC1043 samples a differential input voltage, holds it on C_{S1} and transfers it to capacitor C_{H1} . The voltage on C_{H1} is applied to the LTC2400's input and converted to a digital value.

A reference voltage is applied to the LTC2400's V_{REF} pin and the LTC1043's Pin 6. The remaining half of the LTC1043 divides the reference voltage by two with a high degree of accuracy. This $V_{REF}/2$ voltage is applied to the bottom of C_{H1} , centering the LTC1043's output voltage at midscale (2.5V). This allows the converter to accept bipolar input voltages that swing about a $V_{REF}/2$ point when operating on a single supply.

The LTC1043 achieves its best differential to single-ended conversion when its internal switching frequency operates at a nominal 300Hz, as set by the 0.01 μF capacitor $C1$ and when 1 μF capacitors are used for C_{S1} , C_{S2} , C_{H1} and C_{H2} . Each of the four capacitors should be a film type such as mylar or polypropylene. Conversion accuracy is enhanced by placing a guard shield around C_{S1} and connecting the shield to Pin 10 of the LTC1043. This minimizes nonlinearity that results from stray capacitance transfer errors associated with C_{S1} . Consult the LTC1043 data sheet for more information. As is good practice in all high precision circuits, keep all lead lengths as short as possible to minimize stray capacitance and noise pickup.

Like all delta-sigma converters, the LTC2400's input circuitry causes small current spikes on the input signal. These current spikes perturb the voltage on the LTC1043's C_{H1} , which results in an effective increase in offset voltage and gain error. These errors remain constant over a short time interval and can be removed through software. Without this end-point correction that reduces the effects of zero and full-scale error, the overall accuracy is degraded. The input dynamic range, however, is not compromised and the overall linearity remains at ± 35 ppm, or 14.5bits.

As stated above, the LTC1043 has the highest transfer accuracy when using 1 μF capacitors. Using any other value will compromise the accuracy. For example, 0.1 μF will typically increase the circuit's overall nonlinearity by a factor of 10.

The LTC1043's internal oscillator's frequency will vary with changes in supply voltage. This variation shows up as increased noise and/or gain error. For example, a 100mV change in the LTC1043's supply voltage causes 14ppm gain error in the LTC2400. If this variation is short term, this error appears as noise. The LTC1043 shows the largest gain error at a nominal 3V input. These errors can be reduced by using an external clock. As the LTC1043's

Application Note 78

V_{CC} increases from a nominal 5V, gain errors are most significant and below 5V, linearity errors become more significant.

The circuit's input current is dependent on the input signal's magnitude and the reference voltage. For a 5V reference, the input current is approximately $-1\mu\text{A}$ at -2.5V , $1\mu\text{A}$ at 2.5V and $0\mu\text{A}$ at midscale (0V). The values may vary from part to part. Figure 3's input is analogous to a $2\mu\text{F}$ capacitor in parallel with a $2.5\text{M}\Omega$ connected to ground. The LTC1043's nominal 800Ω switch resistance

is between the source and the $2\mu\text{F}$ capacitance. This description applies to cases where a capacitor is connected in parallel to the LTC2400's input.

This topology is better suited to lower level signals and higher source impedances than a similar topology without the 1/2 reference point. Operation about the 1/2 reference point minimizes the input current passed from the LTC2400 and reduces the effect of the gain error variation that results from internal oscillator frequency change in the LTC1043.

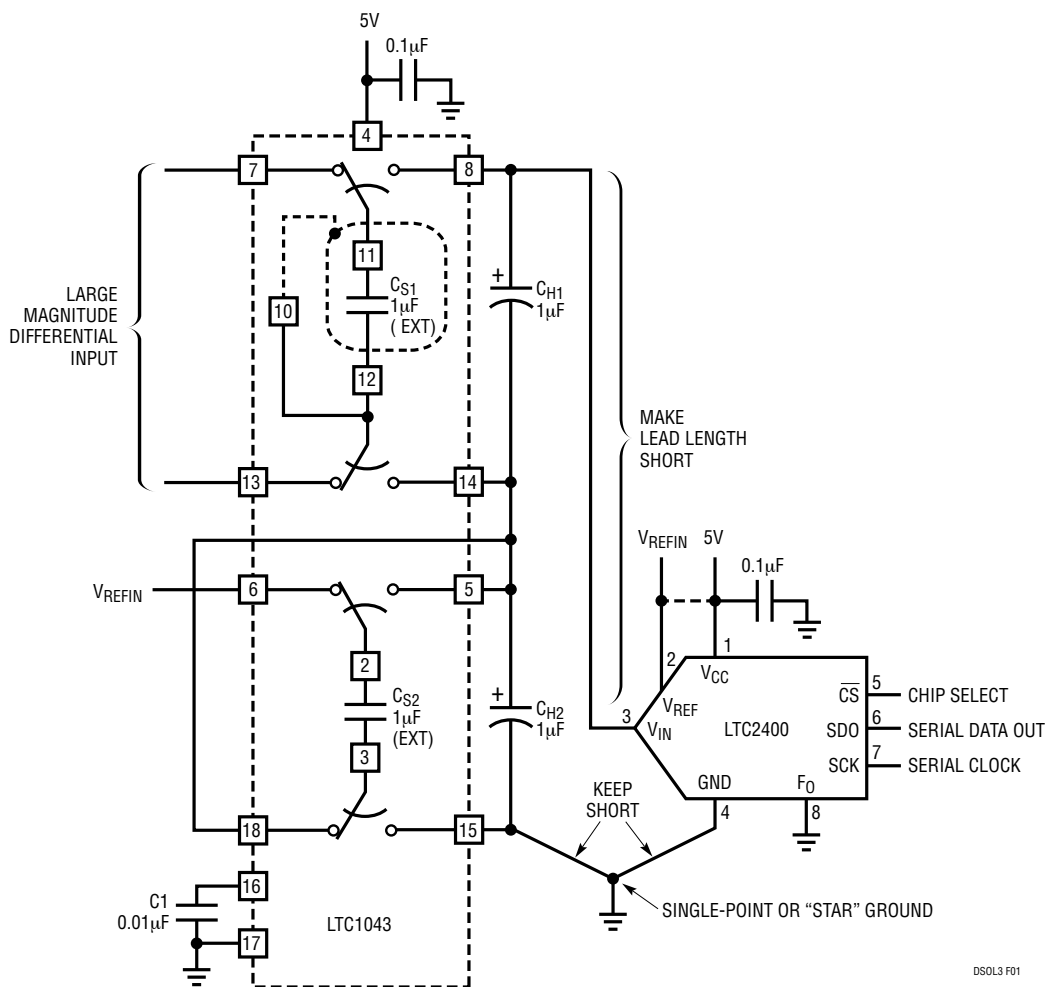

Figure 3. Differential Input 24-Bit A/D Converter with Half-Scale Zero for Bipolar Input Signals

DS03 F01

Application Note 78

Circuit 4

High Accuracy, Differential to Single-Ended Conversion for Wide Range Bipolar Input Signals

Bipolar Differential to Single-Ended Converter Drives the LTC2400's Input Rail-to-Rail

SPECIFICATIONS

$V_{CC} = V_{REF} = \text{LT1236-5}; V_{FS} = \pm 2.45\text{V};$
 $R_{SOURCE} = 175\Omega$ (Balanced)

PARAMETER	CIRCUIT (MEASURED)	LTC2400	TOTAL (UNITS)
Input Voltage Range	± 2.45		V
Zero Error	22	1.5	μV
Input Current	See Text		
Nonlinearity	± 2.5	4	ppm
Input-Referred Noise (without averaging)	6.5	1.5	μV_{RMS}
Input-Referred Noise (averaged 64 readings)	1		μV_{RMS}
Resolution (with averaged readings)	22.2		Bits
Overall Accuracy (uncalibrated)	17.1		Bits
Supply Voltage	5	5	V
Supply Current	2.1	0.2	mA
CMRR	118		dB
Common Mode Range	0 to 5		V

OPERATION

The circuit in Figure 4 is ideal for wide dynamic range differential signals in applications that have a 5V supply. The circuit uses one-half of an LTC1043 to perform a differential to single-ended conversion over an input common mode range that includes the power supplies. This half of the LTC1043 samples a differential input voltage, holds it on C_{S1} and transfers it to capacitor C_{H1} . The voltage on C_{H1} is buffered, applied to the LTC2400's input and converted to a digital value.

A reference voltage is applied to the LTC2400's V_{REF} pin and the LTC1043's Pin 6. The remaining half of the LTC1043 divides the reference voltage by two with a high degree of accuracy. This $V_{REF}/2$ voltage is applied to the bottom of C_{H1} , centering the LTC1043's output voltage at

midscale. This allows the converter to accept bipolar input voltages that swing about a $V_{REF}/2$ point when operating on a single supply.

The LTC1043 achieves its best differential to single-ended conversion when its internal switching frequency operates at a nominal 300Hz, as set by the $0.01\mu\text{F}$ capacitor $C1$ and when $1\mu\text{F}$ capacitors are used for C_{S1} , C_{S2} , C_{H1} and C_{H2} . Each of these four capacitors should be a film type such as mylar or polypropylene. Conversion accuracy is enhanced by placing a guard shield around C_{S1} and connecting the shield to Pin 10 of the LTC1043. This minimizes nonlinearity that results from stray capacitance transfer errors associated with C_{S1} . Consult the LTC1043 data sheet for more information. As is good practice in all high precision circuits, keep all lead lengths as short as possible to minimize stray capacitance and noise pickup.

The circuit in Figure 4 improves on unbuffered LTC1043 circuits, providing an order of magnitude improvement in linearity ($\pm 2.5\text{ppm}$) by buffering the voltage on C_{H1} . The circuit also improves linearity by buffering the voltage on C_{H1} with an LTC1152 operating at unity gain. If a 10V supply is available, the LTC1050 can be used instead of the LTC1152.

As stated above, the LTC1043 has the highest transfer accuracy when using $1\mu\text{F}$ capacitors. Using any other value will compromise the accuracy. For example, $0.1\mu\text{F}$ will typically increase the circuit's overall nonlinearity, and degrade CMRR by an order of magnitude.

Another source of error is thermocouple effects that occur in soldered connections starting with the LTC1043's input traces and ending with the connections to the LTC2400's input and ground pins. Any temperature changes in any of the low level circuitry's connections will cause perturbations in the final conversion result. Their effects can be

Application Note 78

minimized by controlling thermal gradients between pairs of connection by judicious placement of heat sources, components and copper heat spreaders under the pads and by insulating the circuit against moving air.

The circuit's input current is dependent on the input signal's common mode voltage. The input current is

approximately -100nA at $V_{IN(CM)} = -2.5\text{V}$, 100nA at $V_{IN(CM)} = 2.5\text{V}$ and $0\mu\text{A}$ at $V_{IN(CM)} = 0\text{V}$. The values may vary from part to part. Figure 4's input is analogous to a $2\mu\text{F}$ capacitor in parallel with a $25\text{M}\Omega$ connected to ground. The LTC1043's nominal 800Ω switch resistance is between the source and the $2\mu\text{F}$ capacitance.

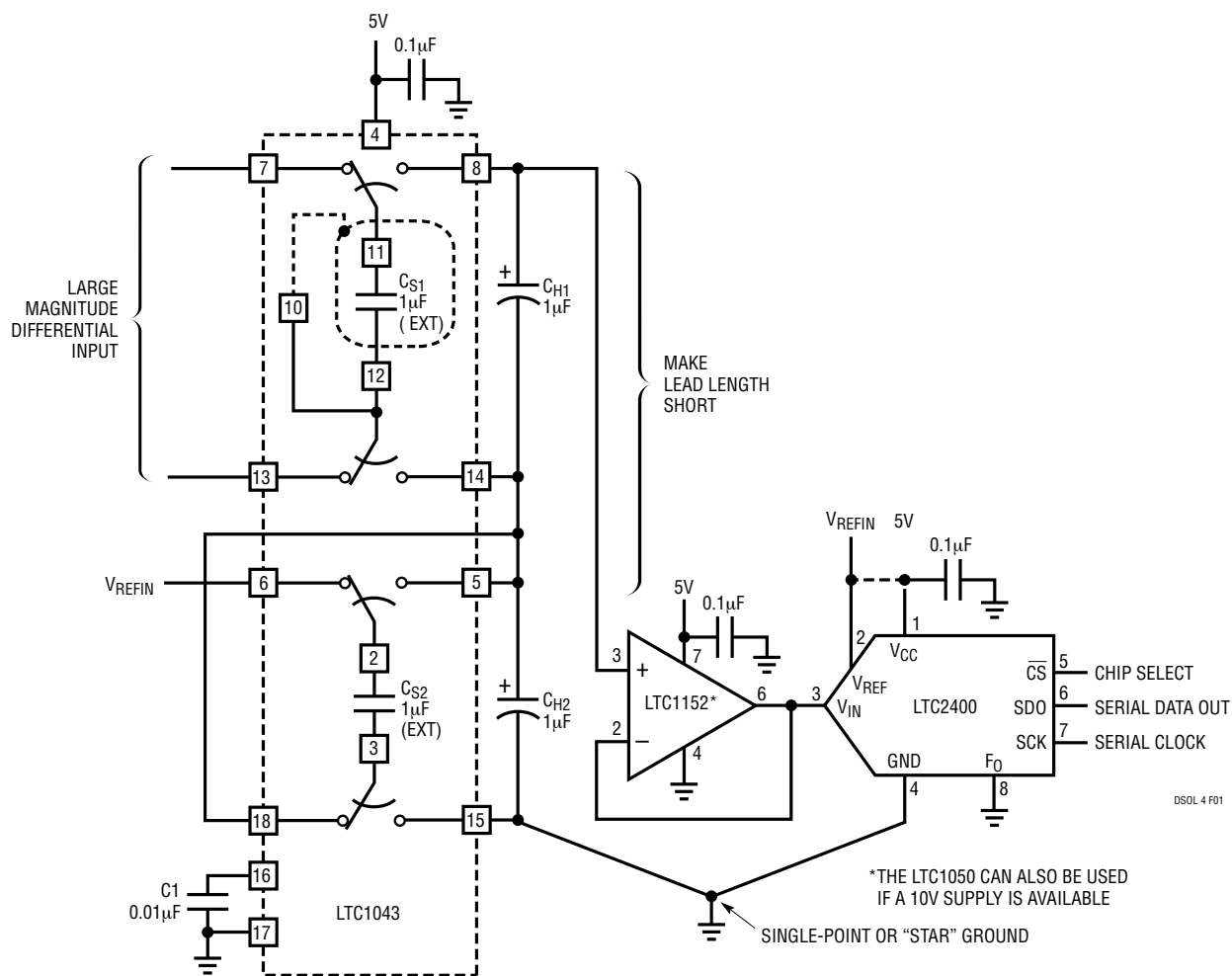

Figure 4. High Accuracy, Bipolar Differential to Single-Ended Converter Drives the LTC2400's Input Rail-to-Rail

Application Note 78

Circuit 5

Low Level, High Accuracy, Bipolar Input Differential to Single-Ended Signal Conversion for 24-Bit A/D

Single Supply Differential to Single-Ended Conversion Circuit Amplifies Low Level Bipolar Signals and Maintains the LTC2400's High Accuracy

SPECIFICATIONS

$V_{CC} = V_{REF} = \text{LT1236-5}$; $V_{FS} = \pm 125\text{mV}$;
 $R_{SOURCE} = 175\Omega$ (Balanced)

PARAMETER	CIRCUIT (MEASURED)	LTC2400 ONLY	TOTAL (UNITS)
Input Voltage Range	± 125		mV
Zero Error	25	1.5	μV
Input Current	See Text		
Nonlinearity	± 2.5	4	ppm
Input-Referred Noise (without averaging)	1*	1.5	μV
Input-Referred Noise (averaged 64 readings)	0.12*		μV
Resolution (with averaged readings)	21.0		Bits
Overall Accuracy (uncalibrated)**	17.0		Bits
Supply Voltage	5	5	V
Supply Current	1.2	0.2	mA
CMRR	118		dB
Common Mode Range	0 to 5		V

* Input-referred noise with a gain of 20.

** Does not include gain setting resistors.

OPERATION

The circuit in Figure 5 is ideal for wide dynamic range differential bridge outputs in applications that have a 5V supply. The circuit uses one-half of an LTC1043 to perform a differential to single-ended conversion over an input common mode range that includes the power supplies. This half of the LTC1043 samples a differential input voltage, holds it on C_{S1} and transfers it to capacitor C_{H1} . The voltage on C_{H1} is buffered, applied to the LTC2400's input and converted to a digital value.

A reference voltage is applied to the LTC2400's V_{REF} pin and the LTC1043's Pin 6. The remaining half of the LTC1043 divides the reference voltage by two with a high degree of accuracy. This $V_{REF}/2$ voltage is applied to the

bottom of C_{H1} , centering the LTC1043's output voltage at midscale. This allows the converter to accept bipolar input voltages that swing about a $V_{REF}/2$ point when operating on a single supply.

The LTC1043 achieves its best differential to single-ended conversion when its internal switching frequency operates at a nominal 300Hz, as set by the 0.01 μF capacitor C1 and when 1 μF capacitors are used for C_{S1} , C_{S2} , C_{H1} and C_{H2} . Each of these four capacitors should be a film type such as mylar or polypropylene. Conversion accuracy is enhanced by placing a guard shield around C_{S1} and connecting the shield to Pin 10 of the LTC1043. This minimizes nonlinearity that results from stray capacitance transfer errors associated with C_{S1} . Consult the LTC1043 data sheet for more information. As is good practice in all high precision circuits, keep all lead lengths as short as possible to minimize stray capacitance and noise pickup.

The circuit in Figure 5 improves on unbuffered LTC1043 circuits, providing an order of magnitude improvement in linearity ($\pm 2.5\text{ppm}$) by buffering the voltage on C_{H1} . One-half of an LTC1051 is used, with its gain set by R1 and R2 ($A_V = 1 + R1/R2$). The remaining half of the LTC1051 buffers the voltage on the bottom of C_{H1} before it is applied to R2.

As stated above, the LTC1043 has the highest transfer accuracy when using 1 μF capacitors. Using any other value will compromise the accuracy. For example, 0.1 μF will typically increase the circuit's overall nonlinearity by an order of magnitude.

Another source of error is thermocouple effects that occur in soldered connections starting with the LTC1043's input traces and ending with the connection at the LTC2400's input and ground pins. Any temperature changes in any of the low level circuitry's connections will cause perturbations in the final conversion result. Their effects can be

minimized by ensuring uniform temperature at pairs of junctions between dissimilar metals and by sealing the circuit against moving air.

The circuit's input current is dependent on the input signal's common mode voltage. The input current is approximately -100nA at -2.5V , 100nA at 2.5V and $0\mu\text{A}$ at midscale (0V). The values may vary from part to part. Figure 5's input is analogous to a $2\mu\text{F}$ capacitor in parallel with a $25\text{M}\Omega$ connected to ground. The LTC1043's nominal 800Ω switch resistance is between the source and the $2\mu\text{F}$ capacitance.

Resistors R1 and R2 set the gain of the op amp that drives the LTC2400. The practical gain range with this topology as shown is from 5 to 100 unless the op amp supply

voltage is increased. At a gain of less than five, the common mode input range of the LTC1051 becomes a constraint, which prevents using the A/D's full dynamic range.

The use of a higher supply voltage for the LTC1051 allows a higher common mode input voltage and, therefore, is suitable for lower gain and greater differential input voltage. The higher supply voltage is not necessary if the rail-to-rail LTC1152 is used.

Lower reference voltage provides an additional benefit of increased LTC2400 linearity. Whereas the linearity error is $\pm 4\text{ppm}$ with a 5V reference, it drops to $\pm 2\text{ppm}$ with a 2.5V reference. This translates to a lower offset when using midscale as the zero point.

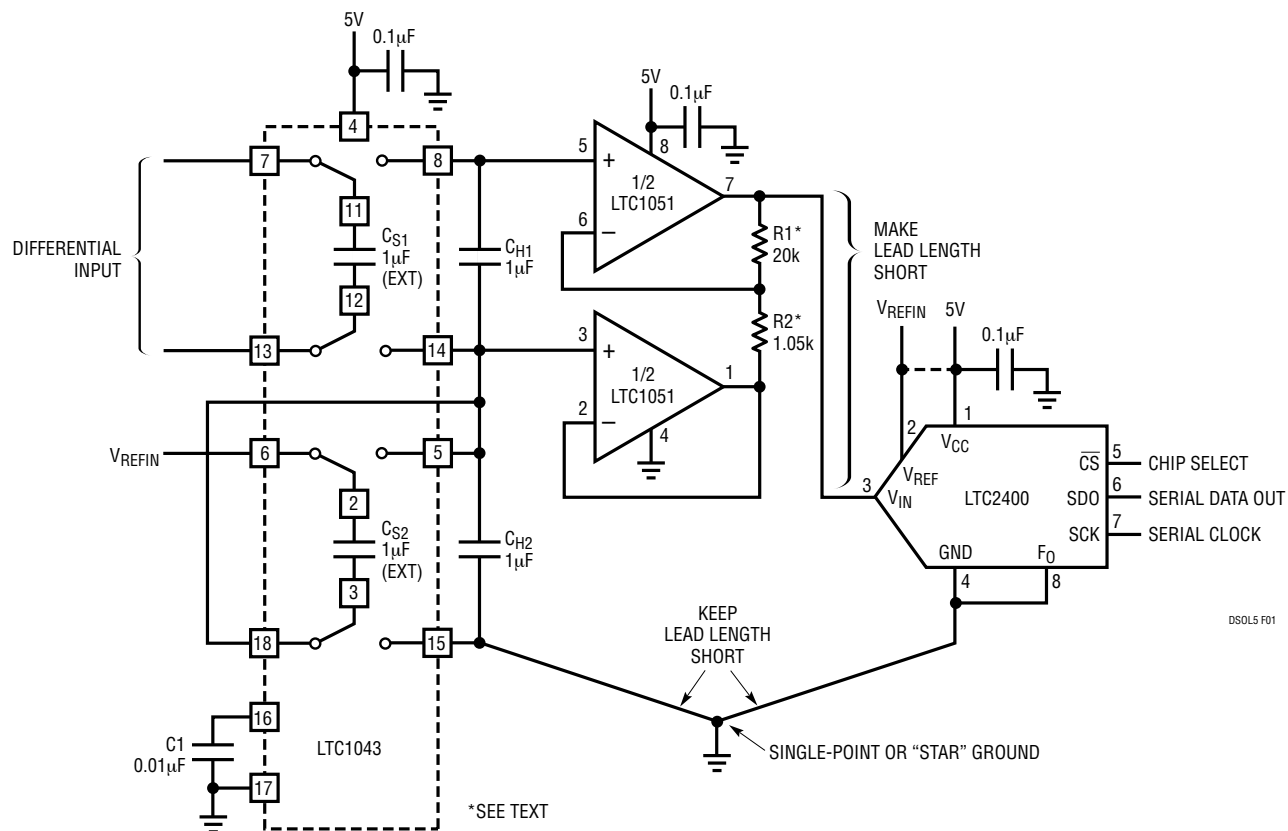

Figure 5. This Single Supply Differential to Single-Ended Conversion Circuit Amplifies Low Level Bipolar Signals and Maintains the LTC2400's High Accuracy

Application Note 78

Circuit 6 LTC2400 Differential to Single-Ended Converter for Single 5V Supply

This Converter Has High Accuracy, Very Low Offset and Offset Drift, Rail-to-Rail Input Common Mode Range and is “Live at Zero”

SPECIFICATIONS

$V_{CC} = V_{REF} = \text{LT1019-2.5}; R_{SOURCE} = 175\Omega$ (Balanced)

PARAMETER	CIRCUIT (MEASURED)	LTC2400	TOTAL (UNITS)
Input Voltage Range	-0.5 to 5		mV
Zero Error	2	1.5	μV
Input Current	See Text		
Nonlinearity	± 5	4	ppm
Noise (without averaging)	0.21*	1.5	μV_{RMS}
Noise (averaged 64 readings)	0.026*		μV_{RMS}
Resolution (with averaged readings)	17.6		Bits
Overall Accuracy (uncalibrated**)	17.6		Bits
Supply Voltage	5	5	V
Supply Current	2.6	0.2	mA
CMRR	120		dB
Common Mode Range	0 to 5		V

*Input referred noise with a gain of 101

**Does not include gain setting resistors, offset and gain error removed

OPERATION

The circuit in Figure 6 is ideal for low level differential signals, typically 2mV/V, in single supply applications and features a “live at zero” operation. The circuit combines an LTC1043 and LTC1050 as a differential to single-ended amplifier that has an input common mode range that includes the power supplies. It uses the LTC1043 to sample a differential input voltage, holds it on C_S and transfers it to a ground-referred capacitor C_H , completing the conversion to single-ended. The voltage on C_H is applied to the LTC1050’s noninverting input and amplified by the gain set by resistors R1 and R2 (101X for the values shown). The amplifier’s output is then converted to a digital value by the LTC2400.

The circuit uses a simple voltage reference (the Schottky diode and NPN transistor) to bias the single-ended signal approximately 270mV above ground. For single supply applications, this bias voltage and the circuit’s “live at zero” operation allows the LTC1050 and the LTC2400 to amplify and convert signals that include inputs below ground.

The LTC1043 achieves its best differential to single-ended conversion when its internal switching frequency operates at a nominal 300Hz, as set by the 0.01 μF capacitor C1, and when 1 μF capacitors are used for C_S and C_H . C_S and C_H should be a film type such as mylar or polypropylene. Conversion accuracy is enhanced by placing a guard shield around C_S and connecting the shield to Pin 10 of the LTC1043. This minimizes nonlinearity that results from stray capacitance transfer errors associated with C_S . Consult the LTC1043 data sheet for more information. As is good practice in all high precision circuits, keep all lead lengths as short as possible to minimize stray capacitance and noise pickup.

As stated above, the LTC1043 has the highest transfer accuracy when using 1 μF capacitors. Using any other value will compromise the accuracy. For example, 0.1 μF will typically increase the circuit’s overall nonlinearity tenfold.

The LTC1050’s closed-loop gain accuracy is affected by the tolerance of the ratio of the gain-setting resistors. If cost considerations preclude using low tolerance resistors (0.02% or better), the processor to which the LTC2400 is connected can be used to perform software correction. Operated as a follower, the LTC1050’s gain and linearity error is less than 0.001%.

The circuit uses 2.5V to excite the 2mV/V bridge, producing a low level output. Best performance is achieved using bandwidth limiting as shown and the attenuator at the LTC2400's input to reduce the input-referred noise. The LTC1050's noise gain of 100 allows adequate headroom for the expected signal magnitude. This is followed by an attenuator that reduces the signal for an overall gain of 16.8. This gain is the typical point where the input-referred noise is minimized.

A source of errors is thermocouple effects that occur in soldered connections. Their effects are most pronounced in the circuit's low level portion, before the LTC1050's output. Any temperature changes in any of the low level

circuitry's connections will cause linearity perturbations in the final conversion result. These effects can be minimized by balancing the thermocouple connections with reversed redundant connections and by sealing the circuit against moving air.

The circuit's input current is dependent on the input signal's common mode voltage. The input current is approximately 100nA at $V_{IN(CM)} = 5V$, dropping to zero at $V_{IN(CM)} = 0V$. The values may vary from part to part. Figure 6's input is analogous to a 2 μ F capacitor in parallel with a 25M Ω connected to ground. The LTC1043's nominal 800 Ω switch resistance is between the source and the 2 μ F capacitance.

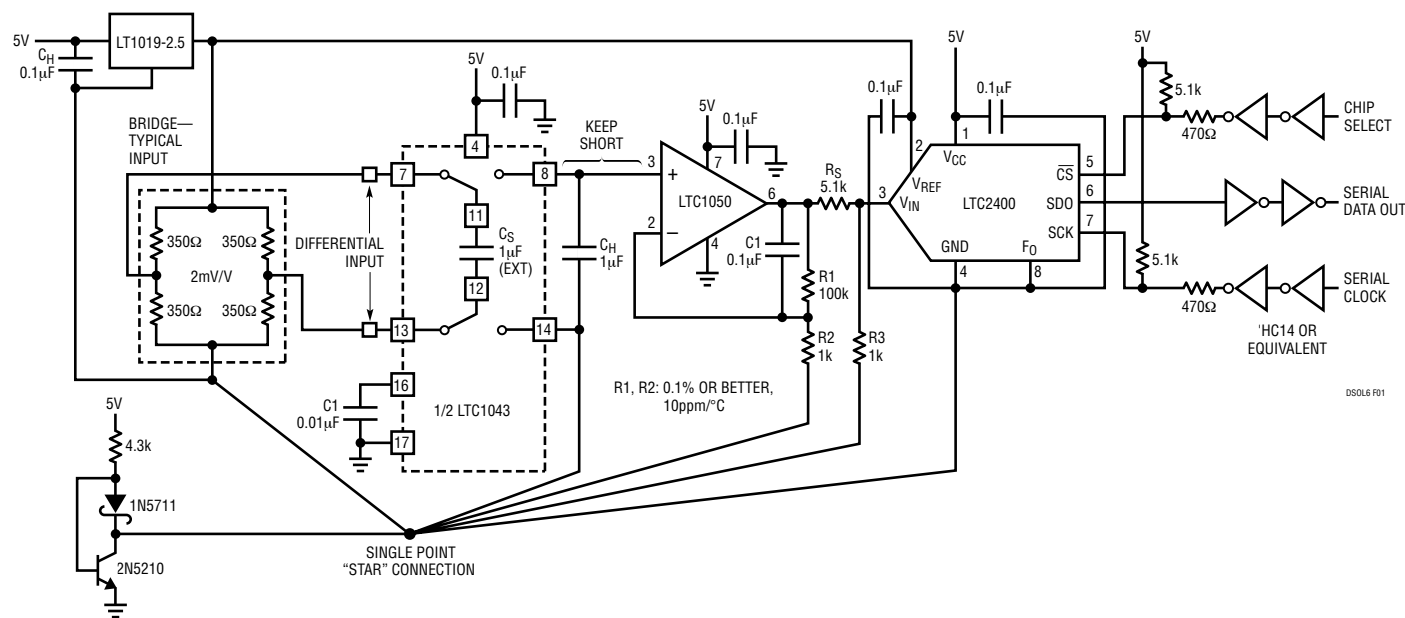

Figure 6. Single Supply Differential to Single-Ended Converter for Low Level Inputs with "Live at Zero" Operation

Application Note 78

LTC2400 Bonus Circuit #1

An Extremely High Resolution LTC2400-P_T RTD Temperature Digitizer

The circuit shown below uses an LTC2400 to digitize the output of a conditioned 100Ω P_T RTD. Using an RTD in combination with the LTC2400, temperatures to 200°C can be measured with a high degree of resolution. The circuit below incorporates a low noise bipolar operational amplifier, the LT[®]1028, configured for a gain of 92. In using low noise preamplification, the effective noise floor of the LTC2400 is reduced by the same amount. As a result, the circuit offers a potential resolution of 0.001°C.

Achieving this level of resolution requires careful thermal design and minimizing RTD self-heating effects. Resistors

R1, R2, R3 and R4 should be stable, precision resistors, such as Vishay S102 types or their equivalent. Furthermore, these resistors should exhibit very low coefficient of temperature or should be temperature-stabilized by placing the preamplifier circuit in an enclosure. Alternatively, precision resistor networks can be used and are available from Vishay or Caddock. The excitation current generated by the V_{REF}-R1-R2 combination is low enough for most sensors that RTD self-heating effect is near the noise floor of the LTC2400 (1.5μV_{RMS}).

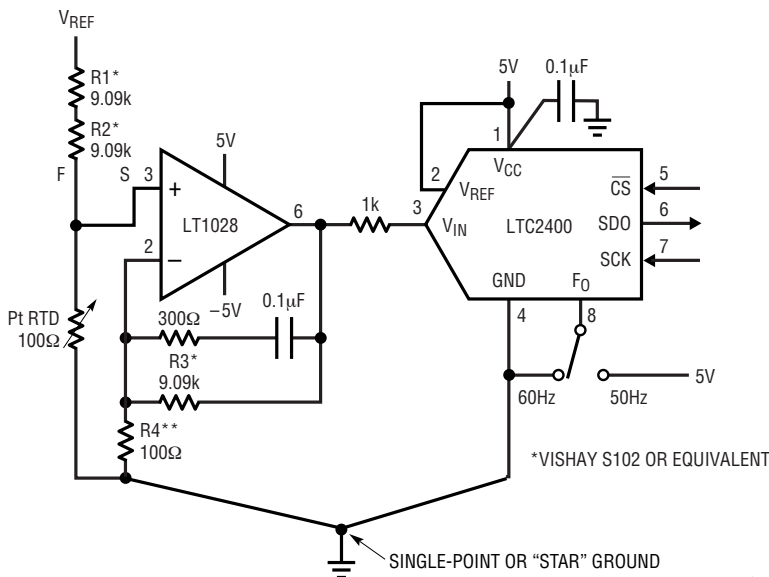

LTC2400 Bonus Circuit #1: An Extremely High Resolution LTC2400-P_T RTD Temperature Digitizer

AN78 BCF1

LTC2400 Bonus Circuit #2

A High Resolution LTC2400-Based Type S Thermocouple Digitizer with Improved Cold Junction Compensation

The figure shown below illustrates a simple interface circuit that demonstrates the practicality of direct thermocouple connection to the LTC2400 using low output voltage thermocouples (a Type S thermocouple, as shown, produces a full-scale output voltage of 18mV). This circuit uses the LT1025, a micropower thermocouple cold junction compensator, to sense the temperature of the cold junction and introduce an offset voltage. This offset voltage is equal in magnitude, but opposite in polarity, to the voltage generated by the thermocouple cable/PC board termination.

This circuit can be easily adapted for use with other thermocouple types—simply replace the thermocouple

(note the polarity of the wires!) and connect to the most appropriate output pin on the LT1025. To minimize any additional error into the measurement, the LT1025 must be mounted at the cold junction and the connections made to the LT1025, the thermocouple, and the LTC2400 must be isothermal.

Because of the LTC2400's noise floor, this circuit is capable of resolving temperatures to within 0.25°C without averaging. Since the LTC2400 does not exhibit any easily discernible quantization effects, averaging multiple readings can significantly extend the resolution for slow-varying processes.

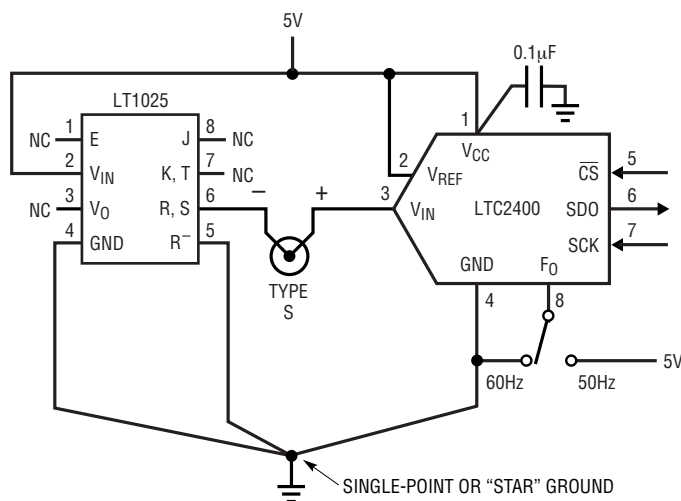

THERMOCOUPLE TYPE	SEEBECK COEFFICIENT
E	60.9µV/°C
J	51.7µV/°C
K, T	40.6µV/°C
R, S	6µV/°C

AN78 BC#2

LTC2400 Bonus Circuit #2: A High Resolution LTC2400-Based Type S Thermocouple Digitizer with Improved Cold Junction Compensation

