

# Using the LTC1325 Battery Management IC

Anthony Ng, Peter Schwartz, Robert Reay,  
Richard Markell

## INTRODUCTION

For a variety of reasons, it is desirable to charge batteries as rapidly as possible. At the same time, overcharging must be limited to prolong battery life. Such limitation of overcharging depends on factors such as the choice of charge termination technique and the use of multi-rate/multi-stage charging schemes. The majority of battery charger ICs available today lock the user into one fixed charging regimen, with at best a limited number of customization options to suit a variety of application needs or battery types. The LTC<sup>®</sup>1325 addresses these shortcomings by providing the user with all the functional blocks needed to implement a simple but highly flexible battery charger (see Figure 1) which not only addresses the issue of charging batteries but also those of battery conditioning and capacity monitoring. A microprocessor interacts with the LTC1325 through a serial interface to control the operation of its functional blocks, allowing software to expand the scope and flexibility of the charger circuit.

This Application Note was written with the following objectives in mind :

- Provide users with an insight into the architecture and operation of the LTC1325.
- Outline basic techniques for charging various battery types.
- Present a variety of useful, tried and tested charging circuits.
- Give an overview of the most common battery types and their characteristics.
- Clarify specialized and application-specific terminology. Definitions are provided in the text, as well as in Appendix C.

LT, LTC and LT are registered trademarks of Linear Technology Corporation.

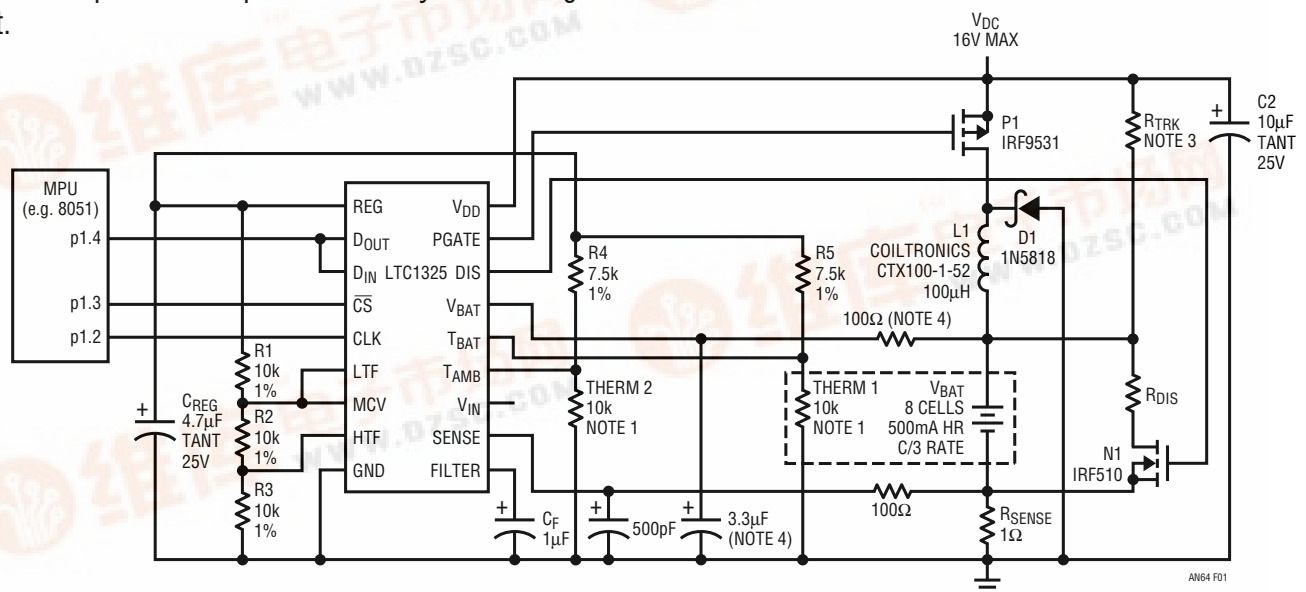

NOTE 1: THERMISTORS 1 AND 2 ARE PANASONIC ERT-D2FHL103S NTC THERMISTORS OR EQUIVALENT.  
NOTE 2:  $V_{REF} = 160mV$ ,  $R_{SENSE} = 1$  FOR C/3 CHARGE RATE (160mA).  
NOTE 3: CHOOSE FOR C/20 TRICKLE CHARGE RATE.  
NOTE 4: 2.0k AND 47µF FOR COMPATIBILITY WITH LITHIUM-ION AND LEAD-ACID

Figure 1. Complete LTC1325 Battery Management System



# Application Note 64

---

## LTC1325 PRIMER

The main features of the LTC1325 may be summarized as follows:

- It has all the functional blocks needed to build a charger: a 10-bit Analog-to-Digital Converter (ADC), fault detection circuitry, a switching regulator controller with a MOSFET driver, a programmable timer, a precision 3.072V regulator for powering external temperature sensors, and a programmable battery voltage divider.
- The functional blocks are placed under the control of an external microprocessor for ready adaptability to different charging algorithms, battery chemistries, or charge rates.
- Communication with the microprocessor is via a simple serial interface, configurable for 3-wire or 4-wire operation.
- It has autonomous fault detection circuitry to protect the battery against temperature or voltage extremes.
- In addition to charging, the part can discharge batteries for battery conditioning purposes.
- It includes on-chip circuitry for an accurate battery capacity monitor (Gas Gauge).
- It charges batteries using a switching buck regulator for highest efficiency and lowest power dissipation.
- The wide supply voltage range ( $V_{DD}$ ) of 4.5V to 16V allows the battery charger to be powered from the charging supply while charging batteries of up to 8 cells in series.
- It can charge batteries which require charging voltages greater than  $V_{DD}$ .
- It can charge batteries from charging supplies greater than  $V_{DD}$ .
- A shutdown mode drops the supply current to 30 $\mu$ A.

## Charging Circuit

Unlike most other charger ICs which employ a linear regulator, the LTC1325 charges batteries using a switching buck regulator. This approach simultaneously maximizes efficiency and minimizes power dissipation. The only external power components needed are an inductor, a P-channel MOSFET switch, a sense resistor and a catch diode (see Figure 1). An internal, programmable battery voltage divider which accommodates 1 to 16 cells removes the need for an external resistive divider (for batteries with voltages below the maximum  $V_{DD}$  of 16V). All the circuits needed for controlling the loop are integrated on-chip and no external ICs are required. The LTC1325 operates from 4.5V to 16V so that it can be powered directly from the charging supply. The wide supply range makes it possible to charge up to 8 cells without the need for an external regulator to drop the charging supply down to the supply range of the LTC1325. These features make the LTC1325 easy to use. When charging is completed and the charging supply is removed, the chip does not load down other system supplies. If the LTC1325 is powered from a system supply, the microprocessor can program it into shutdown mode in which the quiescent current drops to 30 $\mu$ A. In shutdown mode the digital inputs stay alive to await the wake-up signal from the microprocessor.

The buck regulator control circuit maintains the average voltage across the sense resistor ( $R_{SENSE}$ ) at  $V_{DAC}$  (see Figure 2). In addition, a programmable duty cycle can modulate the P-channel MOSFET driver output (PGATE) to reduce average charging current. The average charging current is given by:

$$I_{CHRG} = V_{DAC}(\text{duty cycle})/R_{sense}$$

The microprocessor can set  $V_{DAC}$  to one of four values, and the duty cycle to one of five values, giving 20 possible  $I_{CHRG}$  values with a single  $R_{SENSE}$  resistor.

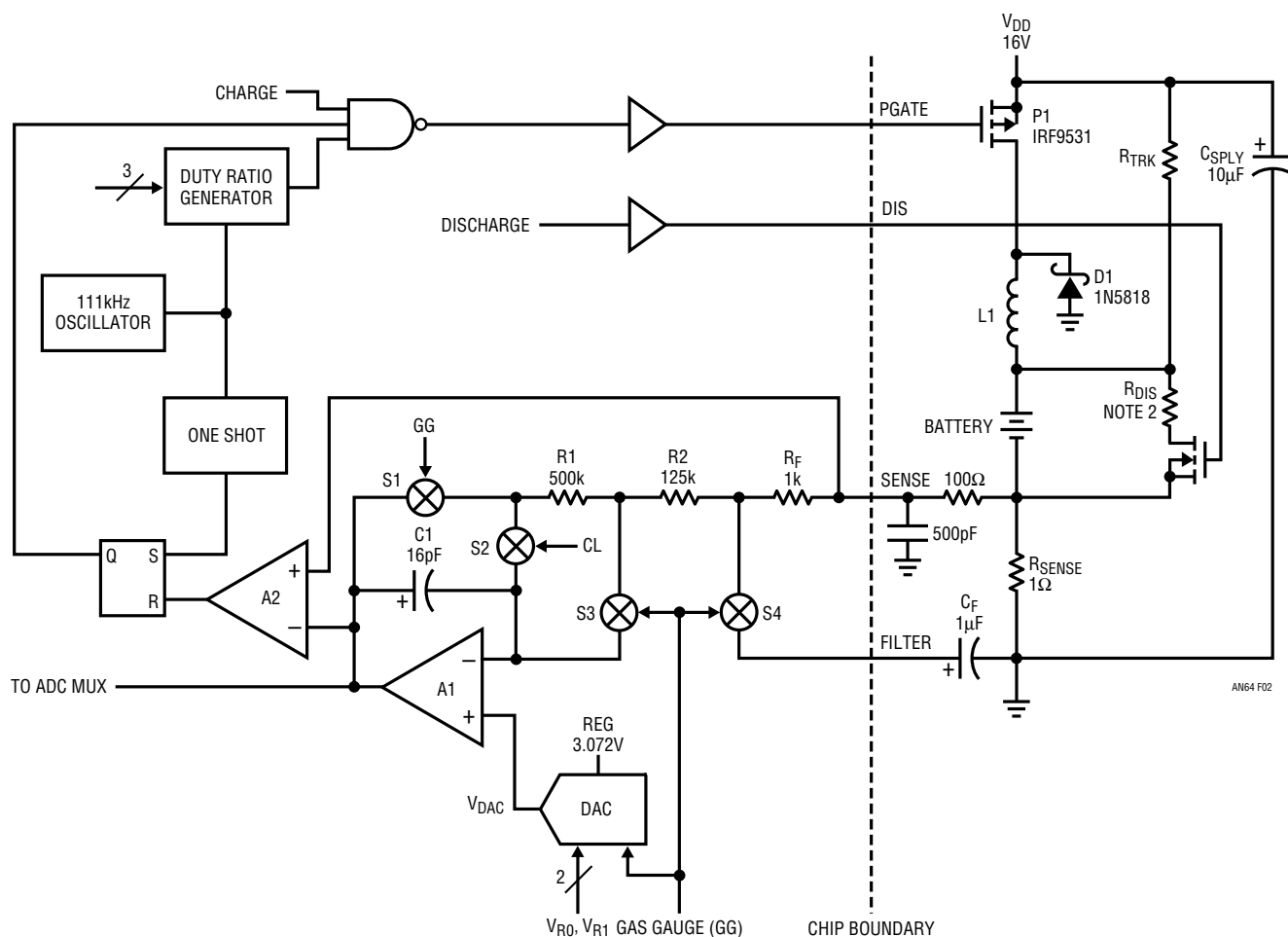

**Figure 2. LTC1325 Charge, Discharge and Gas Gauge Circuit**

## Charge Termination

Virtually any known charge termination technique can be implemented with the LTC1325. The most common of these are based on battery temperature ( $T_{BAT}$ ), cell voltage ( $V_{CELL}$ ), time ( $t$ ), ambient temperature ( $T_{AMB}$ ), or a combination of these parameters. Unlike other fast charging ICs, the LTC1325 does not lock the user into a particular termination technique and any shortcomings of that technique. Instead, it provides the microprocessor a means to measure  $T_{BAT}$ ,  $T_{AMB}$  and  $V_{CELL}$ . By keeping track of elapsed time, the microprocessor has the means to calculate all existing termination techniques (including  $dT_{BAT}/dt$  and  $d^2V_{BAT}/dt^2$ ), and perform averaging to reduce the probability of false termination. This flexibility also means

that a single circuit can charge Nickel-Cadmium, Nickel-Metal Hydride, Sealed Lead-Acid, and Lithium-Ion batteries. The LTC1325 has an on-chip 10-bit successive approximation ADC with a 5-channel input multiplexer. Three channels are dedicated to  $T_{BAT}$ ,  $V_{CELL}$  and the Gas Gauge (see section on Capacity Monitoring); the other two channels can be used for other purposes such as sensing  $T_{AMB}$  or another external sensor. The LTC1325 can be programmed into Idle mode in which the charge loop is turned off. This permits measurements to be made without the switching noise that is present across the battery during charging.

# Application Note 64

## Fault Protection

The LTC1325 monitors battery temperature, cell voltage and elapsed time for faults and prevents the initiation or the continuation of charging should a fault arise. The fault detection circuit (see Figure 3) consists of comparators which monitor  $T_{BAT}$  and  $V_{CELL}$  to detect low temperature faults (LTF), high temperature faults (HTF), low cell voltages (BATR, EDV) and high cell voltages (MCV). The LTF, HTF and MCV thresholds are set by an external resistor divider (R1 to R4) to maximize flexibility. The LTC1325 also includes a timer that permits the microprocessor to set charging time before a timer fault occurs to one of eight values: 5, 10, 20, 40, 80, 160, 320 minutes or no time-out. Selecting “no time-out” disables timer faults (the time-out period is in effect set to infinity).

## Battery Conditioning

Under some operating or storage conditions, certain battery types (most notably NiCd) lose their full capacity. It is often necessary to subject such batteries to deep discharge and charge cycles to restore the lost capacity. The LTC1325 can be programmed into Discharge mode in which it automatically discharges each cell to 0.9V. This voltage is defined as the End-of-Discharge Voltage (EDV). Fault protection remains active in Discharge mode to protect the battery against temperature extremes (LTF, HTF) and to detect the EDV discharge termination point.

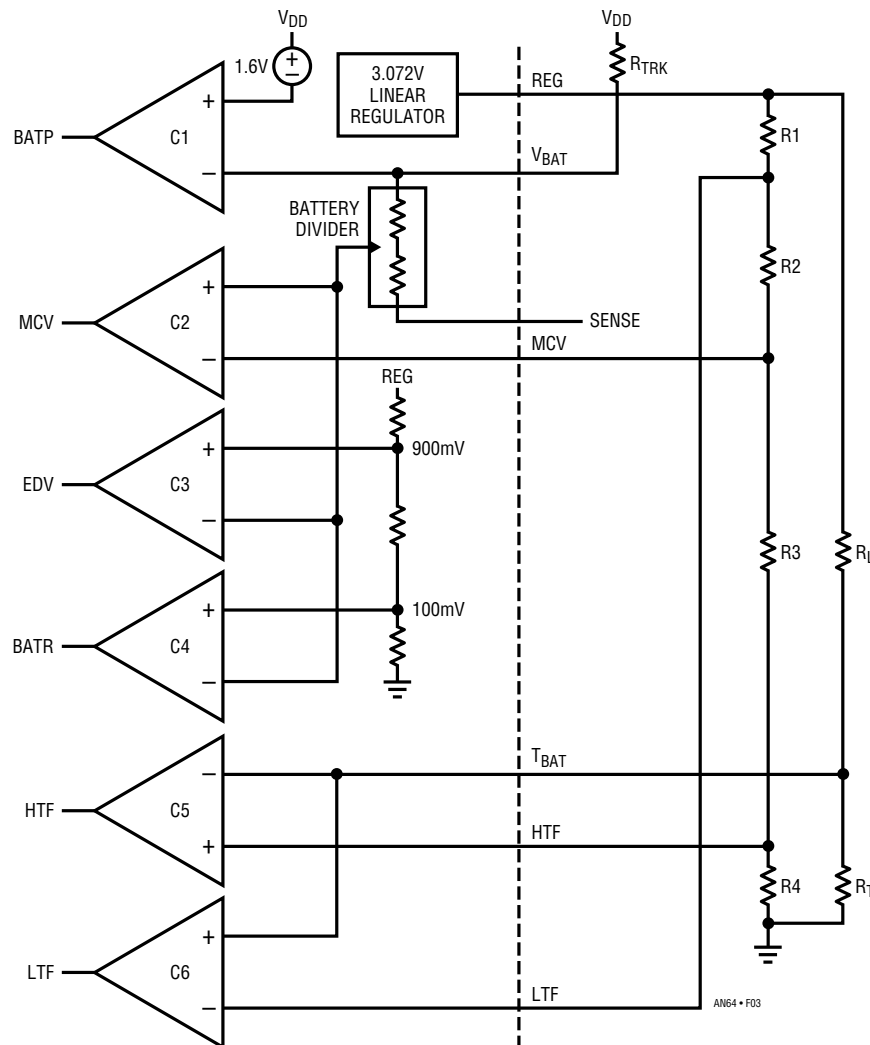

Figure 3. LTC1325 Fault Detection Circuitry

## Capacity Monitoring

The LTC1325 may be programmed into Gas Gauge mode (GG = 1 in Figure 2). In this mode, the sense resistor is used to sense the battery load current. The battery load is connected between  $V_{BAT}$  and ground so that the load current passes through the sense resistor, producing a negative voltage at the Sense pin. The Sense pin voltage is filtered by a  $1k\Omega \times C_F$  lowpass filter and multiplied by a gain of  $-4$  via amplifier A1. The output of A1 is converted by the ADC whenever the gas gauge channel is selected by the microprocessor. By accumulating gas gauge measurements over time, the microprocessor can determine how much charge has left the battery and what capacity remains.

## APPLICATIONS CIRCUITS

### Charging Nickel Cadmium and Nickel Metal Hydride Batteries

It is desirable to charge batteries as fully and rapidly as possible. At the same time it is necessary to limit overcharging, which can adversely affect battery life. To meet these requirements, multi-stage charging algorithms are recommended for NiCd and NiMH batteries. Multi-stage charging algorithms consist of 2 or 3 stages:

2-Stage:   Fast Charge  
              Trickle Charge

3-Stage:   Fast Charge  
              Top-Off Charge  
              Trickle Charge

During Fast Charge, the battery is charged at the maximum permitted rate to near full capacity. In Top-Off the battery is charged at a lower rate to bring it to full capacity thus minimizing overcharge. Finally, during Trickle Charge, the battery is charged at a rate that just compensates for self-

discharge to maintain it at full capacity. Recommendations of the battery manufacturer determine which algorithm to use. In general, the best way to limit overcharge is to use a primary charge termination technique and several secondary techniques for redundancy. Regardless of the algorithm, the basic circuit to charge up to 8 NiCd or NiMH cells is shown in Figure 1.

### Examples of Charging Algorithms

#### 2-Stage NiCd

Fast Charge    C/1 rate,  $-\Delta V$  (15mV) primary termination  
                  Time-out secondary termination (80 minutes)

Trickle Charge C/10 rate, no termination needed

#### 2-Stage NiCd

Fast Charge    C/1 rate, TCO (45°C) primary termination  
                  Time-out secondary termination (80 minutes)

Trickle Charge C/10 rate, no termination needed.

#### 3-Stage NiMH

Fast Charge    C/1 rate,  $\Delta TCO$  (10°C) primary termination

Top-Off Charge C/10 until secondary termination at  
180 minutes (160 min + 20 min)

Trickle Charge C/40 rate, no termination

#### 3-Stage NiMH

Quick Charge   C/3 rate, 120 minute (80 min + 40 min) to  
160 minute time-out  
TCO (40°C) secondary termination

Top-Off Charge C/10 rate until  $V_{CELL} = 1.5V$

Trickle Charge C/40 rate, no termination

All these algorithms may be realized with the circuit in Figure 1. Only the software and perhaps some component values change.

# Application Note 64

---

## Conditioning Batteries

When overcharged for extended periods of time, some NiCd batteries exhibit what is commonly called the “memory effect.” The voltage per cell drops 150mV which may lead the user to conclude that the battery is at the end of its discharge curve. This condition may be reversed by deeply discharging and recharging the battery. The LTC1325 can be programmed to discharge a battery until its per cell voltage falls below 0.9V (EDV). As shown in Figure 1, the external N-channel MOSFET N1 is turned on to discharge the battery.  $R_{DIS}$  is selected such that the discharge current,  $V_{BAT}/R_{DIS}$ , is within the allowable limits set by the battery manufacturer. Discharge currents can be large with high capacity batteries. The power rating of  $R_{DIS}$  should be greater than  $I_{DIS}^2 \times R_{DIS}$ . The source of N1 may be terminated to the top of  $R_{SENSE}$  (as in Figure 1) or to ground. The former is preferred since the  $V_{BAT}$  pin monitors the battery voltage for EDV and not the battery voltage plus the drop across  $R_{SENSE}$ . If desired it is possible to adjust the EDV voltage via the internal battery divider setting as outlined in the next section.

## Using the End-of-Discharge Voltage Fail-Safe

The LTC1325, when commanded to do so, will discharge a battery until its cell voltage goes below 900mV nominal, at which point an EDV fail-safe occurs and the DIS pin is taken low to stop discharge. This function of the IC is most commonly used for the protection and conditioning of NiCd and NiMH batteries, but may also be used to condition a Lead-Acid battery or to reset the Gas Gauge to a known point (remaining battery capacity equals zero) for any battery type. Immediately following discharge, the voltage per cell for NiCd and NiMH batteries will typically “rebound” by 100mV to 200mV. The controlling software will need to take this rebound into account to prevent a possible oscillation in which the ADC would be read, the EDV and fail-safe bits reset, and the battery discharged for a few more seconds before again indicating EDV and stopping the discharge.

If desired, the battery divider can be programmed to divide by a factor that is less than the number of cells in the battery. For example, if the divider is programmed to divide-by-5 when the number of cells in the battery is six, the EDV fault occurs at  $(5 \times 0.9)/6$  or 0.75V. Similarly,

programming the divider to divide-by-6 with a three-cell Lead-Acid battery would give an EDV of  $(6 \times 0.9)/3 = 1.8V$  per cell at termination of discharge.

## Operating from Charging Power Supplies of Above 16V

The LTC1325 has a maximum  $V_{DD}$  range of 16V. To operate from a higher supply voltage, it is necessary to do two things: add a regulator to drop the higher supply ( $V_{DC}$ ) down to the supply range of the LTC1325 and add a level shifter between the PGATE pin and the gate of the external P-channel MOSFET. The level shifter ensures that the P-channel MOSFET can be switched off completely. Figure 4 shows a low cost circuit that will charge up to 8 cells from a 25V supply at 160mA. For 2A charge current, L1 and  $R_{SENSE}$  should be changed to 15 $\mu$ H and 0.08 $\Omega$  respectively.  $V_{DAC}$  is set to 160mV in both cases for best accuracy. The number of cells that can be charged is affected by any series resistance in the charge path. At high charging currents low resistance inter-cell connections such as solder tabs are recommended.

The zener diode D3 is used to drop the 25V  $V_{DC}$  down to 16V to serve as  $V_{DD}$  supply to the LTC1325. R7 should not be greater than 220 $\Omega$ . Alternatively, a 3-terminal regulator (such as the LT<sup>®</sup>1086-12 or LT1085-12) may replace D3, C1 and R7. The regulator output voltage ( $V_{DD}$ ) fixes the number of cells that can be charged with the circuit to about  $V_{DD}/V_{EC}$  where  $V_{EC}$  is the maximum cell voltage expected.

When the battery is removed,  $R_{TRK}$  pulls the  $V_{BAT}$  pin towards  $V_{DC}$ . D4 acts as a clamp to prevent  $V_{BAT}$  from rising above the  $V_{DD}$  supply voltage. D2, C2 and R11 form a simple level shifter. During charging, D2 clamps the voltage at the gate of P1 between  $V_{DC} - V_Z$  and  $V_{DC} + 0.7V$ , where  $V_Z$  is the reverse breakdown voltage of D2.  $V_Z$  is selected to limit the  $V_{GS}$  of P1 to within its maximum rating. For logic-level P-channel MOSFETs with a maximum  $V_{GS}$  of  $\pm 8V$ , D2 may be a 3.9V zener such as the 1N4730A. For standard MOSFETs ( $\pm 20V$   $V_{GS}$  rating), a 1N4740A 10V zener may be used. When power ( $V_{DC}$ ) is first applied,  $V_{DD}$  takes a finite time to charge up to 16V so that the voltage on the PGATE pin is initially 0 and P1 is turned on. D2 breaks down, charging C2 quickly to one zener drop below  $V_{DC}$ . Then as PGATE rises, D2 forward











# Application Note 64

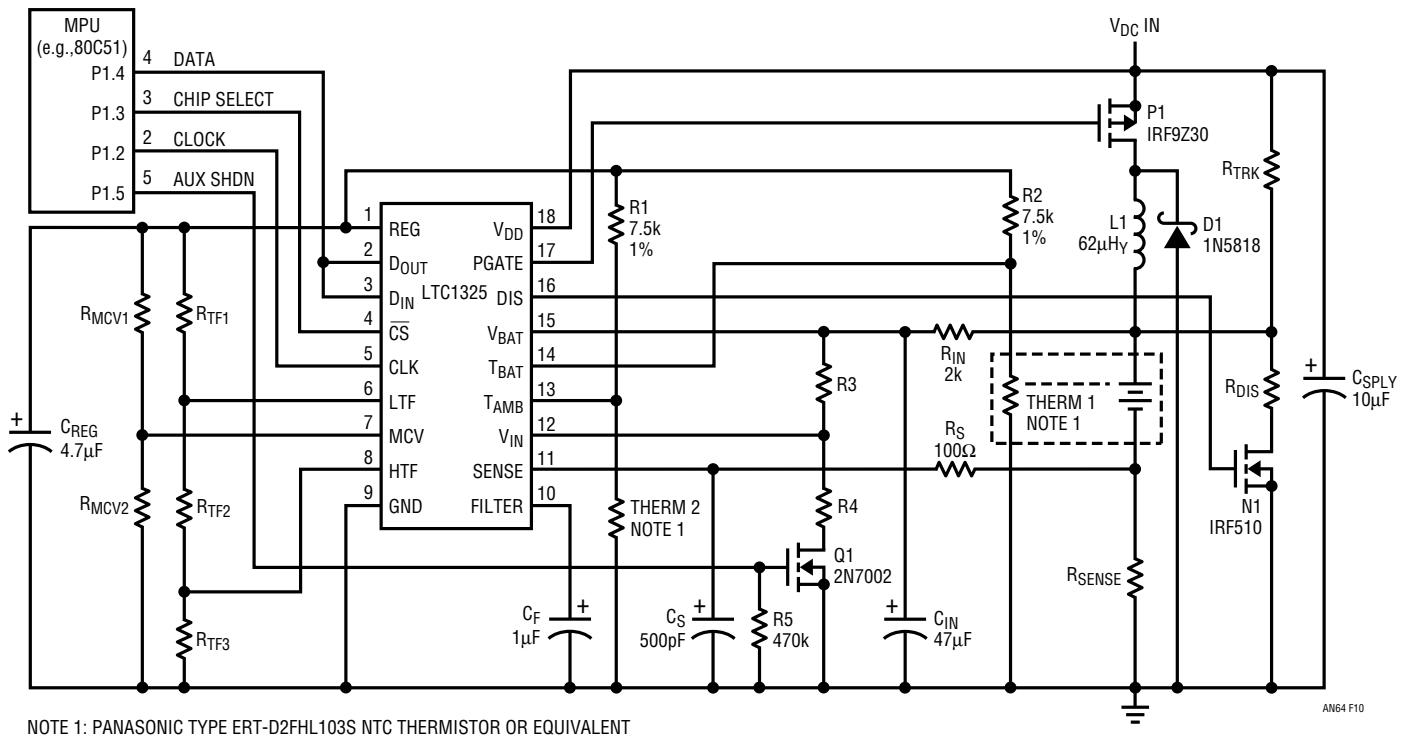

Figure 10. Constant Potential Battery Management System

Batteries that require a CP charging algorithm generally need a rather accurate charging voltage, especially in fast-charge applications. For this reason the LTC1325's internal battery divider often cannot be used to control the charging voltage, due to its tolerance of  $\pm 2\%$  at division ratios other than 1:1. It does, however, remain useful for MCV and/or FEDV detection. For measuring battery voltage an external resistive divider feeding  $V_{IN}$  is recommended. The external divider resistors should be chosen such that the voltage at the  $V_{IN}$  pin will come as close as possible to the ADC's full-scale input voltage without exceeding that value; 3.000V maximum is a good choice. Using a near-full-scale input to the ADC improves measurement accuracy. To further improve charging voltage accuracy, it's a good idea to use  $\pm 0.1\%$  or  $\pm 0.25\%$  tolerance resistors in the battery voltage divider. Under such conditions, the voltage loop error is ideally only the reference error ( $\pm 0.8\%$ ), plus that of the ADC (4 bits out of 1024, or  $\pm 0.4\%$ ) and of the battery divider ( $\pm 0.1\%$  or  $\pm 0.25\%$ ), for a total  $\pm 1.3\%$  or  $\pm 1.5\%$  error.

"Auxiliary Shutdown" is a static line from the microprocessor to a small-signal MOSFET, which prevents the

battery from discharging through the voltage divider string when it is not charging. With the external divider in place, the B ATP flag will always be high except when Auxiliary Shutdown is at a logic low and the battery is not installed in the circuit (see "Charging 'Tall' Batteries" above). Battery voltage fail-safes will remain operational (assuming that they use the  $V_{BAT}$  input) although it may not be possible to make simultaneous use of the MCV and EDV fail-safes with all CP battery types.  $R_{TRK}$ , if needed, maintains the battery in a fully charged condition.

A suitable software algorithm to implement a quasi-CP charger is this:

1. Establish a regular repetition interval for the voltage servo loop.  $t_{LOOP}$  values of 10ms to 20ms give good results.
2. Set  $V_{DAC}$  to 160mV at the highest charge rates for best resolution. Using a 95% maximum PWM duty cycle  $[t_{ON}/(t_{ON} + t_{OFF})]$ ,  $R_{SENSE}$  chosen as  $160mV/(0.95 \times I_{MAX})$ , where  $I_{MAX}$  is the nominal maximum current to be allowed through the battery. A suitable minimum duty cycle is 10%; beyond such a low duty cycle it is

usually better to reduce the peak current through the battery (by programming  $V_{DAC}$ ) than to reduce the duty cycle further.

3. Perform each of the following tasks once each servo loop interval ( $t_{LOOP}$ ):
  - a) Enter Idle mode of operation.
  - b) Read  $V_{CELL}$ .
  - c) Adjust the value entered into a timer register (or a software timer) up or down according to actual  $V_{CELL}$  vs target  $V_{CELL}$ . If  $V_{CELL}$  is too low, the timer value is increased. If  $V_{CELL}$  is too high, the timer value is decreased.
  - d) The maximum Charge time of the LTC1325 has been set at 95% of  $t_{LOOP}$ ; the minimum at 10%. Within that range, the duty cycle at which the loop will operate is set by the timer of 3(c). If the timer's interval is increased ( $V_{CELL}$  too low), the portion of each  $t_{LOOP}$  during which the LTC1325 is put into Charge mode is increased. If the timer's interval is decreased ( $V_{CELL}$  is too high), the LTC1325 is commanded into Idle mode for a greater portion of each  $t_{LOOP}$ .
  - e) If  $t_{ON} < (0.1 \times t_{LOOP})$ , switch  $V_{DAC}$  to the next lower value (note that the  $V_{DAC}$  value of 34mV is not used).
  - f) Repeat (a) through (e) until the average current into the battery, or the net duty cycle, drops below a chosen limit. A timer-based secondary cutoff is often recommended for CP chargers.
  - g) Terminate the software loop with MOSFET P1 in the "off" state, using  $R_{TRK}$  (if required) to maintain the battery's charge.

A flow chart showing the principals of this voltage servo loop is given in Appendix B, Figures B3a and B3b. Figure B3a shows the "ramp-up" from the point where the charger is first turned on to the maximum charging current required and Figure B3b shows the "taper-down" which simulates the necessary CP charging algorithm. (This algorithm is undergoing refinement at press time. For the latest information on its implementation and optimization, please contact LTC.)

$R_{IN}$  and  $C_{IN}$  have greater values in Figure 10 than in most of the circuits in this Application Note. This is because

batteries requiring a CP charge tend to have a significant positive  $\Delta V$  during the interval in which charging current is flowing through them. The time constant of ( $R_{IN} \times C_{IN}$ ) filters the resulting 10ms to 20ms ripple before it is presented to the  $V_{BAT}$  and  $V_{IN}$  pins. If only  $V_{IN}$  input will be used,  $R_{IN}$  may be omitted,  $C_{IN}$  may be placed from  $V_{IN}$  to ground, and its value can be decreased.

The circuit of Figure 10 has deliberately been generalized to provide flexibility across all common battery types. For applications requiring the support of only specific battery types, or which do not need extensive thermal or other protection mechanisms, various components can be modified or removed to minimize cost and board space.

## Overcurrent Protection

Three common scenarios in which battery current can exceed acceptable levels are: accidental shorting of the battery terminals, excessive loads and inserting the battery into the charger in reverse. Battery or charger damage in all three cases can be prevented through the use of a thermal or overcurrent device to limit fault currents. Usually, it is desirable that this device reset itself when the fault goes away. Possible choices are bimetallic (thermostatic) switches and polymer PTC thermistors. The high series resistance of traditional ceramic PTC thermistors, even in the unexcited state, make them unsuitable for this application.

Bimetallic switches operate by sensing battery temperature. By the nature of their operation, these switches cycle on and off as long as the fault remains, causing the battery and all associated components (mechanical as well as electrical) to heat up and cool down repeatedly. Polymer based PTC thermistors such as the Raychem PolySwitch<sup>®</sup> also offer very low series resistance until "tripped," and have the advantages of a faster response and freedom from thermal cycling.

Polymer PTCs should be chosen such that under normal operation, the average charging current ( $V_{DAC}/R_{SENSE}$ ) is less than the Hold Current rating of the PTC to keep it in the low resistance state. Under fault conditions, the Fuse Current should exceed the Trip Current rating of the fuse. This will cause the fuse's resistance to increase dramatically and reduce the fault current to about  $V_{BAT}/R_{FUSE(Trip)}$ .

# Application Note 64

The PolySwitch should ideally be placed between cells in the battery, in close physical contact with one of the cells. In this way the trip point of the device will be reduced as the battery's temperature increases. Such a configuration provides substantial protection for the battery against shorts across its terminals and from excessive load currents. It will also protect the battery if it is accidentally inserted into the charger in reverse.

Figure 11 shows the fault current path when a battery is inserted into a charger in reverse. Potentially damaging currents may flow through this path since the Sense resistor is usually in the region of 1Ω or less. A PolySwitch inside the battery pack (as described above), or in series with the Schottky diode, limits fault currents to safe levels. The following points should be noted in choosing the diode and  $R_{SENSE}$ .

- Normal charging currents should be equal to or less than the holding current rating of the PolySwitch.
- Temperature affects PolySwitch performance. The manufacturer's data should be consulted for derating factors.
- Initial fault currents will be approximately  $V_{BAT}/R_{SENSE}$  if the battery is inserted in reverse. This should exceed the trip current rating of the PolySwitch.
- The wattage of  $R_{SENSE}$  should be high enough to withstand the initial fault currents of  $V_{BAT}/R_{SENSE}$ .

- The surge current rating of D1 should exceed the initial fault current of  $V_{BAT}/R_{SENSE}$ . It may be necessary to confirm the selected diode's applicability with the manufacturer of the part.

In addition to the above scenarios, the battery current may exceed acceptable levels when a battery is inserted into a charger which has the charging supply ( $V_{DC}$ ) turned off. If the  $V_{DC}$  supply exhibits a low impedance path to ground when it is turned off, the diode that is intrinsic to the P-channel MOSFET may turn on to form a battery discharge path which flows from the battery's positive terminal through the inductor, the MOSFET internal diode, the ground lead and the sense resistor before returning to the negative terminal of the battery. This can be prevented by connecting a Schottky diode between  $V_{DC}$  (diode anode) and the source of the P-channel. See the section on "Current Sinking  $V_{DC}$  Sources" for more details.

## Current-Sinking $V_{DC}$ Sources

In some applications, it may be necessary to add a Schottky rectifier between the  $V_{DC}$  supply and the source of MOSFET P1. This rectifier prevents the battery from discharging backwards through MOSFET P1, which could damage P1, L1, or  $R_{SENSE}$ . It is required if the following conditions are met:

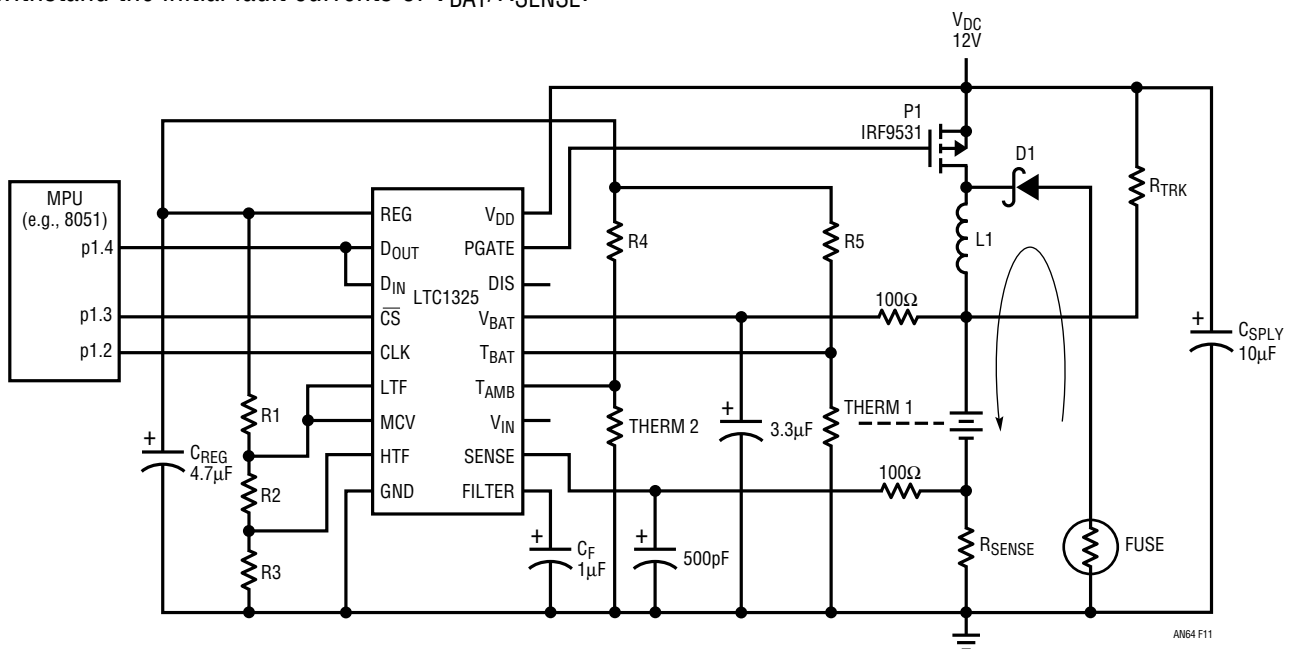

Figure 11. Reversed Battery Protection

- The voltage of the battery being charged can exceed that of the supply.
- The  $V_{DC}$  supply can sink current when it is at a lower voltage than the battery being charged.

Most switching power supplies, such as those used for AC adapter and battery charger supplies in portable computers, have a very small reverse leakage current—several milliamperes at most. These would not generally need the additional Schottky rectifier. Two examples of situations where the rectifier *is* necessary are:

- Charging a 7.2V or greater battery from a 12V car battery using the cigarette lighter socket. Under cold-cranking conditions the 12V nominal battery drops to 6V to 7V and an automobile’s wiring will allow the starter motor to pull current back out of the lighter socket.
- Bench-top testing. Many power supplies have internal protection circuitry which will sink current from the load rather than allow a sourcing load, such as a charged battery, to force current indiscriminately into the supply’s output. Also, any supply with a crowbar represents a possible current-sinking power supply.

Figure 12 depicts a basic charger circuit and shows the proper placement of the Schottky rectifier  $D_{IN}$ .

## CONCLUSION

Through its ability to accept commands from almost any microprocessor, the LTC1325 takes advantage of the power and flexibility of software to avoid locking the user into any given battery type. This almost endless configurability enables the battery system designer to choose the required charge regimen, charge rate and charge termination technique(s) for virtually any task. Possibilities range from a robust but basic battery charging technique to sophisticated multiple-stage charging algorithms, or even several different algorithms entirely, all executed with the same hardware. In this way a wide range of battery types or end application needs can be accommodated with the same circuit. The on-board fault detection circuitry provides additional confidence in the final design by acting as a “watchdog” on the microprocessor and the battery pack. The design of the overall charging circuit is made as simple as possible by incorporating all the functional blocks needed and minimizing the discrete component count. In addition to charging batteries, the LTC1325 has provisions to condition batteries and to measure battery capacity. As with the LTC1325’s charging-related functions, these capabilities are afforded a maximum of versatility and value by being placed almost completely under software control.

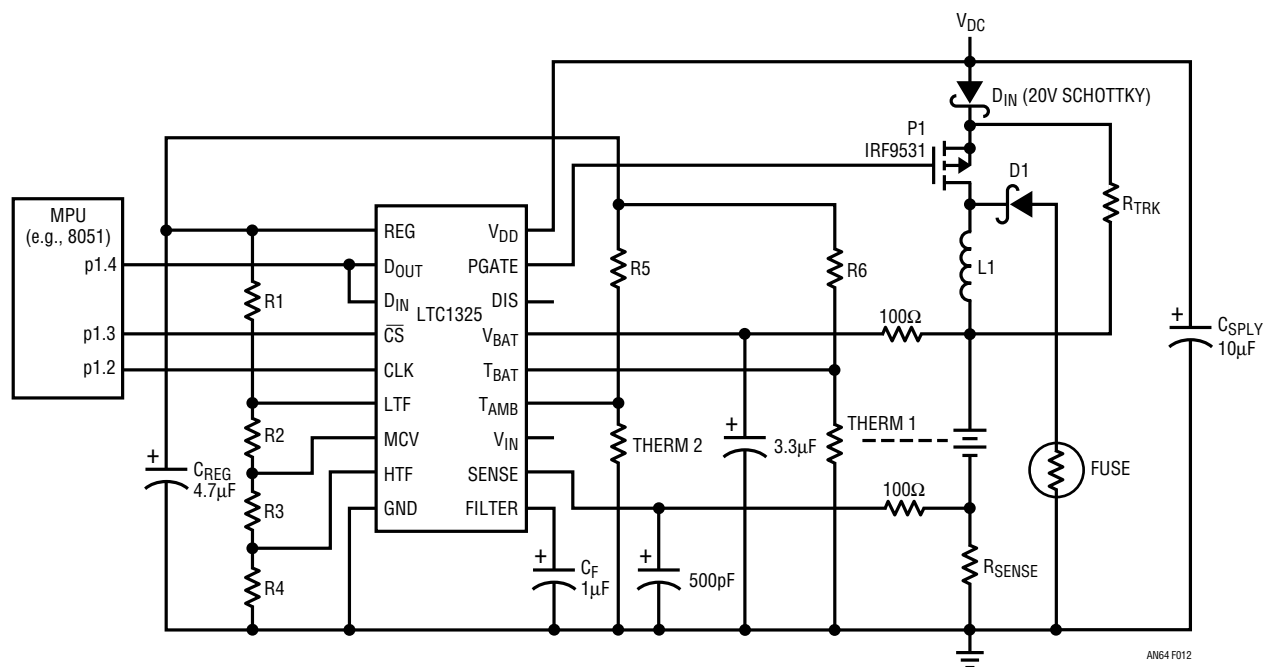

Figure 12. Protection Against Discharging Through  $V_{DC}$

# Application Note 64

## APPENDIX A

### An Overview of Battery Types, Terminology, and Techniques

The world is increasingly relying upon portable electronic equipment, and the rechargeable battery systems (battery, battery charger and ancillary functional blocks) which power that equipment. These battery systems are among the defining elements of end product capability, endurance and life. In spite of this, they are commonly considered a necessary evil; their design and testing, a black art. The truth is that commercially viable battery management systems are comprised of well understood electronic and electrochemical components, with well defined performance characteristics. While this Appendix is not intended as a comprehensive treatment of battery technology, it will provide the equipment engineer with practical information for the choice of battery types and battery management techniques.

There are three rechargeable battery types commonly used in portable devices. These are Nickel-Cadmium (NiCd), Nickel-Metal Hydride (NiMH) and Sealed Lead-Acid (SLA). Lithium-Ion (Li-Ion) is also beginning to receive significant attention, primarily due to its very high energy density (as measured in terms of volume and of weight). Table A1 gives a quick overview of the characteristics of these battery types:

**Table A1. Battery Type Characteristics**

BATTERY CHARACTERISTICS	SEALED LEAD-ACID	NiCd	NiMH	LITHIUM-ION
Energy Density W-h/kg	30	40	60	90
Energy Density W-h/liter	60	100	140	210
Cell Voltage (V)	2.0	1.2	1.2	4.20 Max 3.60 Avg 2.50 Min
Charging Method	Constant Potential	Constant Current	Constant Current	Constant Potential
Discharge Profile	Mildly Sloping	Flat	Flat	Sloping
#Charge/Discharge Cycles*	300	>500	>500	500 to 1000
Self-Discharge	3%/MO	15%/MO	20%/MO	6%/MO
Internal Resistance	Low	Lowest	Moderate	Highest
Discharge Rate**	> 4C	> 10C	3C	< 2C

\* Until 80% of rated capacity is available upon discharge.

\*\* C is the capacity rating of the battery in Ampere-Hours.

A useful first-approximation view of a rechargeable battery is that it is a container into which energy may be poured as desired, to be subsequently consumed as needed. This analogy generally conjures up an image of a jar of water, which would impose few restrictions upon rates of filling or emptying the vessel. In fact, a battery is more akin to a bottle of thick syrup, with the bottle having a narrow mouth and a wide base. With such a bottle, the syrup must be delivered into the bottle at a controlled rate and pressure (to prevent possible damage to the delivery system or to the neck of the bottle), and may be drawn at a maximum rate determined by the amount of syrup in the bottle and the bottle's shape. To carry this analogy just a little further, it is true of batteries, as it is with the hypothetical syrup bottle, that it is possible to get almost all of the contents out of the container — but it may take a long time to get the last few percent out. The flow rate will vary with the amount remaining, meaning that in situations where a high rate of discharge is required of a battery, not all the “contents of the bottle” — not all the available energy — will be instantaneously available to the discharging circuit.

Battery recharge times generally break down into several groups. The most common of these are the “standard-charge,” suitable for overnight applications (typically requiring 16 hours) and the “fast-charge” (typically two hours or less). Between the two is the “quick-charge,” which is in many respects akin to a standard-charge but requires a useably shorter interval (about five hours). Examples of standard-charge applications are cordless telephones and UPS systems for small computers. Quick-charge batteries are commonly found in devices which will see brief but significant power drain several times daily, such as cellular phones. Laptop computers and cordless tools are excellent locations for fast-charge systems. In these and other fast-charge uses there is a high average drain on the battery, and the product's value is determined in large part by the availability of battery power upon demand. The LTC1325 forms a comprehensive core for battery management systems operating at any of these charge rates; all that need be changed are a few external components and the microprocessor algorithm used to control the charge cycle. **Only batteries designed and rated for fast-charge should be subjected to a fast-**

**charge regimen.** Similarly, only batteries rated for quick-charge should be subjected to quick-charging conditions.

As might be expected, there are important differences between the charging regimens used for the four different battery types. There are also more similarities than might be expected. Each of the following sections is intended to stand alone, but it is suggested that the battery system designer read all four sections in order to get a feel for where the similarities and differences between battery families lie. Terms which are specific to the battery user community, or which have special meanings in this Appendix, are defined in the Glossary in Appendix C.

## Using Nickel-Cadmium Batteries

Nickel-Cadmium batteries, in various forms, have been in use for over 50 years. During that time they have evolved from expensive, special purpose devices to the battery of choice for most portable equipment. The availability of inexpensive sealed cells, with ongoing improvements in energy density and cycle life, have been the driving forces for this acceptance. The LTC1325 adds to this the ability to easily implement fast-charge routines, gas gauge algorithms and/or switch mode constant current sources, all using very little system overhead and printed circuit board space.

A quick run-down of the pros and cons of Nickel-Cadmium batteries:

The “pros”:

- Good energy density, both by weight and by volume, relative to competing technologies.
- Acceptable charging rates range from 0.1C to 2C and beyond.
- Most NiCd cells can accept a continuous overcharge current of 0.1C.
- A very flat discharge profile.
- The lowest cell impedance of the major battery technologies.
- Well understood and documented electrical behavior and electrochemistry.
- Cells and batteries are available in a variety of sizes from a number of vendors.

- Special purpose batteries are available with extended operating temperature ranges.

The “cons”:

- Cadmium is commonly considered an environmentally hazardous material. Nickel is also coming under environmental scrutiny.
- NiCd cells have a significant self-discharge rate (0.5%/day at room temperature).

## Nickel-Cadmium Standard-Charge

For applications which can allow a recharge period of about 16 hours — an “overnight” charge — the standard-charge regimen is the method of choice. The reasons for this include:

- Simplest charging algorithm.
- Least expensive charge termination techniques.
- Small power supply required to provide the charging current.
- Small charging circuit power components.
- Low overall charging system power dissipation.

A standard-charge is relatively straightforward to implement. In “cookbook” form, such a charge requires:

- Charging Current: 0.1C.
- Required Charging Voltage: 1.60V/cell or greater, plus charger overhead.
- Charging Temperature Range: 0°C to 45°C.
- Charging Time: 16 hours.
- Charge Termination Method: None required.
- Secondary Charge Termination Methods: None required.
- Special issues which may require further consideration are: wide temperature range charging, wide temperature range discharging and accurate gas gauging at temperature extremes.

A charging current of 0.1C, fed to the battery for 16 hours, will deliver (16 hours × 0.1C) = 160% of standard capacity to the battery. At temperatures between 0°C and 25°C, the resulting 60% overcharge is adequate to ensure that the battery is returned to 100% of its standard capacity. Once

## Application Note 64

---

the cells in the battery reach their actual capacity for the operating temperature, mild gassing will occur, but not enough to cause venting or other cell damage. Since most NiCd batteries will accept a continuous 0.1C charge at any case temperature between 0°C and 50°C, charge termination per se is usually not required. For specialized applications, extended temperature range batteries are available which can be charged at 70°C. Charging at temperatures below 0°C is also possible if the charge current is “throttled back” as the battery temperature decreases. The charging current under such conditions should linearly decrease from 0.1C at 0°C to zero current at –15°C to –25°C. In wide temperature range applications, the use of a battery (or ambient) temperature sensor in conjunction with the LTC1325 is an excellent way to provide positive control of battery charging current versus temperature, thereby extending battery life.

The charge acceptance of NiCd batteries is reduced significantly at temperatures above 40°C. This effect is only marginally mitigated by longer charge times, and should be taken into account if gas gauging is to be done over extended temperature ranges. By way of example, a battery that can be fully recharged at 25°C in 16 hours will reach only about 75% of standard capacity at 45°C after 48 hours. Again, no damage will be done to the battery, but its available capacity during subsequent discharge will be less than one would otherwise expect. If correction parameters for the gas gauging function of the LTC1325 will be employed, it is recommended that the manufacturer of the specific battery in question be consulted.

In the same way that charge acceptance is reduced for temperatures above 25°C, actual capacity is reduced when discharging a cell at temperatures much removed from 25°C. The battery temperatures at which actual capacity is 85% of standard capacity are approximately 0°C and 50°C. Again, for more specific data, the manufacturer of the battery to be used should be contacted.

Specially rated NiCd cells can support a higher rate of relatively uncontrolled overcharge than the ubiquitous 0.1C. This allows the quick-charge regimen, which is typically 0.33C for 5 hours. Charging current and interval aside, most other details for performing a quick-charge are the same as for a standard-charge. It is often desirable in quick-charge regimens to use a timed charge, reducing

the charger’s output current to a 0.05C trickle-charge after the five-hour recharge interval. Checking the cell manufacturer’s data will provide further information on this, as well as the specified charge rate, permissible continuous overcharge rate, and information on the allowable temperature range.

Under some conditions, it may be desirable to use a lower charging rate than 0.1C (for instance, to reduce charger power requirements). This is feasible only within a narrow range: NiCd cells have a reduced charge acceptance at lower charge rates, lengthening the required charge time. This, and their self-discharge characteristic (approximately 0.5%/day at 23°C), combine to make anything under 0.05C a very slow and potentially unreliable charge rate for most cell types.

### Nickel-Cadmium Fast-Charge

In recent years a class of applications has arisen for which 5 hours to 16 hours may constitute an excessive recharge time. Portable computer equipment is an excellent example of this — even if the battery pack in a laptop can be “swapped out” for external recharge, it is often needed again within several hours, fully charged and ready for use. In this case, the fast-charge techniques which the LTC1325 makes practical are the way to go. A fast-charge regimen implies:

- 90% recharge within one hour; 100% recharge within two to three hours.
- A method for determining the optimum charge termination point(s).
- Backup charge termination method(s) to ensure best battery life.
- Highly efficient use of available charging energy.
- Increased product value through better battery utilization and greater customer satisfaction.

Unlike the standard-charge and quick-charge regimens, there is no one best way to fast-charge a Nickel-Cadmium battery. Variables introduced by the allowable cost and size of the end application, the continuing evolution of Ni-Cd cells to accommodate faster charge rates, and the specific battery vendor(s) chosen will all influence the final choice of charging technique. There are several areas of

industry consensus, however, regarding the suitable fast-charging of NiCd batteries:

- Charging Current: 1.0C to 2.0C.
- Required Charging Voltage: 1.80V/cell or greater, plus charger overhead.
- Charging Temperature Range: 10°C to 40°C.
- Charging Time: Three hours (90% of charge is typically returned within the first hour).
- Suitable Charge Termination Methods: See Table A2.
- Suitable Secondary Charge Termination Methods: See Table A2.
- Special issues which may require further consideration are: accurate gas gauging at temperatures over 25° C, and appropriate mechanical integration of the battery pack into the end equipment.

The objective of fast-charging a NiCd battery is, crudely stated, to cram as much energy as it takes to bring the battery back to a fully charged state into that battery in as short a time as possible. Since current is proportional to

energy divided by time, the charging current should be as high as the battery system will reasonably allow. Generally, NiCd batteries rated for fast-charge use are designed around a 1C to 2C maximum charging rate. At the 1C rate, more than 90% of the usable discharge capacity of the battery is typically returned within the first hour. Higher rate cells (up to 5C) do exist, but they are more oriented to special applications and will not be discussed here, except to note that the LTC1325 is capable of handling the charging routines required for such cells, should that be required.

Fast-charging has compelling benefits, but places certain demands upon the battery system. A properly performed fast-charge can yield a cell life of as many as 500 charge/discharge cycles. The high charging rates involved, however, do engender correspondingly more rapid electrochemical reactions within the cell. Once the cell goes into overcharge, these reactions cause a rapid increase in internal cell pressure, and in the cell's temperature. Figure A1 shows the Voltage, Pressure and Temperature characteristics of a Nickel-Cadmium cell being charged at the 1C rate. It can be seen that, as the cell approaches 100% of

**Table A2. Fast-Charge Termination Techniques for Nickel-Cadmium Batteries**

Voltage Cutoff (VCO)	Uses absolute cell voltage to determine the cell's state of charge. Not generally recommended for use in NiCd charging regimens.
Negative $\Delta V$ ( $-\Delta V$ )	Looks for the relatively pronounced downward slope in cell voltage which a NiCd exhibits ( $\approx 30\text{mV}$ to $50\text{mV}$ ) upon entering overcharge. Very common in NiCd applications due to its simplicity and reliability.
Zero $\Delta V$	Waits for the time when the voltage of cell under charge stops rising, and is "at the top of the curve" prior to the downslope seen in overcharge. Sometimes preferred over $-\Delta V$ , as it causes less overcharging.
Voltage Slope (dV/dt)	Looks for an increasing slope in cell voltage (positive dV/dt) which occurs somewhat before the cell reaches 100% returned charge (prior to the Zero $\Delta V$ point). No longer widely used.
Inflection Point Cutoff ( $d^2V/dt^2$ , IPCO)	As a NiCd cell approaches full charge, the rate of its voltage rise begins to level off. This method looks for a zero or, more commonly, slightly negative value of the second derivative of cell voltage with respect to time.
Absolute Temperature Cutoff (TCO)	Uses the cell's case temperature (which will undergo a rapid rise as the cell enters high-rate overcharge) to determine when to terminate high-rate charging. A good backup method, but too susceptible to variations in ambient temperature conditions to make a good primary cutoff technique.
Incremental Temperature Cutoff ( $\Delta TCO$ )	Uses a specified increase of a NiCd cell's case temperature, relative to the ambient temperature, to determine when to terminate high-rate charging. A popular, relatively inexpensive and reliable cutoff method.
Delta Temperature/Delta Time ( $\Delta T/\Delta t$ )	Uses the rate of increase of a NiCd cell's case temperature to determine the point at which to terminate the high-rate charge. This technique is inexpensive and relatively reliable as long as the cell and its housing have been properly characterized.

# Application Note 64

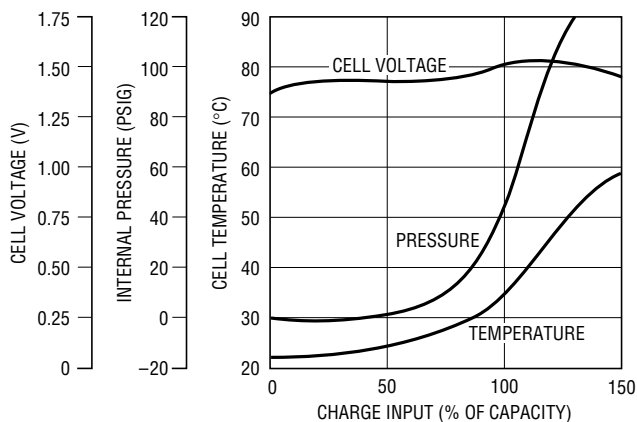

Reproduced with permission by Butterworth-Heinemann, *Rechargeable Batteries Applications Handbook*, copyright 1992

AN64 FA01

**Figure A1. NiCd Voltage, Pressure, and Temperature Characteristics During Charge at 1C (23°C Ambient)**

capacity, the charging current must be reduced or terminated. Left unchecked, overcharge at the **C** rate will ultimately cause the cell's safety vent to open. This results in a loss of gaseous electrolyte to the ambient, and a permanent diminution of cell capacity. Similarly, allowing the temperature of the cell to rise excessively will cause a degradation of the internal materials, again reducing cell life. The science of fast-charging is largely that of determining when the battery has achieved between 90% and 100% of its dischargeable capacity. At that point the charging circuit must switch from the fast-charge current level to a level appropriate to finish the charging of, and/or maintain the charge on, the battery. Some of the common methods for doing this are outlined in Table A2.

As Table A2 shows, there are a number of techniques which have been successfully employed for the purpose of determining when to terminate the high-rate interval of a fast-charge regimen. Individual application requirements, and manufacturer's recommendations, must of course be considered carefully before making a final design decision. Nonetheless, two techniques for detecting the point at which to make the transition from high-rate charging to top-charging have become especially popular over the years, and are used here as examples. These are the  $-\Delta V$  and the  $\Delta TCO$  methods. The  $-\Delta V$  approach looks for a point at which the cell or battery voltage reaches its peak during charging, and holds this maximum value. The high-rate charge is then terminated when the voltage per cell has declined by a value of 15mV to 30mV.  $\Delta TCO$

sensing uses two thermistors to measure the case temperature of the cell, or of one of the cells in a battery, while also measuring the ambient temperature. A 10°C differential between cell and ambient is the typical high-rate termination criterion. (A single-thermistor variant on the "classic"  $\Delta TCO$  approach is made possible through the combined power of the LTC1325 and a microprocessor: cell temperature is measured just before commencing charge, and assumed to be the ambient temperature. This baseline value then becomes the reference against which all further temperature measurements are compared.)

For illustration of the fast-charging of NiCd batteries, this document will use a **1C** charge rate, in a three-stage algorithm. The three stages are:

- Fast-Charge at the **1C** rate, until it is determined by the charging system that the high-rate portion of the charge regimen must be terminated. At this point, a **1C** charge will typically have returned between 90% and 95% of the battery's actual capacity.
- Top-Charge at **0.1C** for two hours, to add an additional **0.2C** to the battery. This will bring the battery back to 100% of usable capacity.
- Trickle-Charge at between **0.02C** and **0.1C** to counter the NiCd's self-discharge value of about 0.5%/day.

Unless the battery is being used in an unusual application, there is little advantage in using a trickle-charge rate different from the **0.1C** top-charge rate, which most NiCd cells can tolerate indefinitely. If the trickle-charge is the same as the top-charge rate, the charge regimen illustrated effectively has only two stages. This is not uncommon for NiCd batteries.

It cannot be overstated that the high-rate portion of a fast-charge regimen must be terminated once the battery being charged has reached the appropriate cutoff point. Murphy has taught us to prepare for the unexpected. So for each method consider: "How can this method fail?" To give just one example of each case: contact resistance in the charging path could mask the downslope of the battery's terminal voltage, causing the microprocessor to miss the  $-\Delta V$  termination point. For  $\Delta TCO$  termination, the ambient temperature might not be indicative of the battery's temperature at the start of charge (e.g., recharging of a battery just removed from a cooler environment to a warmer one),

which would keep a significant battery-to-ambient temperature differential from appearing. Failure of the charger system to recognize the cutoff point, for whatever reason, can quickly and irretrievably damage the battery. To avoid such damage, inexpensive redundancy is the solution. With the capabilities of the LTC1325 already at hand, the best plan is to simply employ both methods. It is then reasonable to expect that one of the two techniques will result in a successful high-rate charge termination. In this example regimen a good choice for the primary high-rate charge termination for NiCd batteries would be  $-\Delta V$  sensing, with  $\Delta TCO$  serving as a backup. To give Murphy's gremlins a harder time of it, there are maximum and minimum operating temperatures and cell voltages which the LTC1325 can be set to recognize. The LTC1325 also has a timer feature which will turn off the charge current to the battery unless the timer is reset within a certain interval. These preset limits serve to protect the battery from severe overcharge even if the system's microprocessor should fail altogether.

As mentioned above, fast-charge current levels can cause rapid gas evolution within a NiCd cell. Since gas recombination inside the cell is slower at reduced temperatures, the pressure inside the cell will rise as the cell temperature decreases. This places a lower limit on the permissible fast-charge temperature range. Similarly, the cell's charge acceptance decreases at elevated temperatures. Hence, although gas recombination occurs much more rapidly, there is the danger of more gas being generated than the cell mechanisms can handle. This places an upper boundary on the fast-charge temperature range. Putting numbers to these limits,  $10^{\circ}\text{C}$  to  $15^{\circ}\text{C}$  are common minimum figures with the high end at  $40^{\circ}\text{C}$  to  $45^{\circ}\text{C}$ . Using the LTC1325 in conjunction with the microprocessor to ensure that the indicated operations occur within the manufacturer's rated temperature limits will significantly extend the life of the cell or battery.

For the most accurate gas gauging it may be desirable to take into account the battery's actual temperature during charge and its temperature during discharge. Both of these have an effect upon the ratio of actual capacity to standard capacity. This effect may be especially pronounced if the battery is charged at an ambient temperature above  $25^{\circ}\text{C}$  and/or discharged at  $0^{\circ}\text{C}$  or below. For specific data with which to calibrate the gas gauge func-

tion against charge and discharge temperatures, the manufacturer of the cells or batteries being used should be contacted.

During fast-charge the battery will get warm and may vent in the unlikely case of overstress or failure. It is prudent engineering to allow for these contingencies in the mechanical design stage of the equipment in which the battery will reside. Again, the manufacturer of the cells or battery to be used should be consulted for specific guidance.

### Using Nickel-Metal Hydride Batteries

The Nickel-Hydrogen couple has been known for at least 20 years, but until recently it has been too costly for all but the most specialized of applications. Recent developments in the manufacture of the NiMH cell, specifically of the hydrogen-bearing negative electrode, has brought NiMH technology into the realm of commercial viability. At present NiMH batteries remain somewhat more expensive than either Nickel-Cadmium or SLA units. However, for applications requiring the energy densities which NiMH provides, it can readily justify its higher price. It should also be noted that NiMH is a mature enough technology to be useful and reliable, yet young enough that prices should continue to decline and performance to improve. The LTC1325's features and flexibility make it an excellent choice for Nickel-Metal Hydride applications, providing the ability to easily implement and modify fast-charge routines, gas gauge algorithms and/or switch-mode constant current sources, all using very little system overhead and printed circuit board space.

A quick rundown of the pros and cons of Nickel-Metal Hydride batteries:

The "pros":

- Excellent energy density, both by weight and by volume, relative to competing technologies.
- Acceptable charging rates range from  $0.1\text{C}$  to  $1\text{C}$  and beyond (fast-charge capability is virtually a given for NiMH).
- A flat discharge profile.
- Well understood and documented electrical behavior and electrochemistry.

## Application Note 64

---

- Cells and batteries are available in a variety of sizes from a number of vendors.
- It is anticipated that new cell formulations will eliminate all cadmium from the NiMH product.

The “cons”:

- Nickel is coming under scrutiny as a potential ecological hazard.
- NiMH cells have a significant self-discharge rate (0.5%/day to 1%/day at room temperature).
- Careful attention to overcharge of NiMH cells is required, even at standard-charge rates.
- NiMH cells command a price premium relative to NiCd cells at the present time.
- NiMH cells do not presently cover the same temperature ranges as either NiCd or SLA units.

### Nickel-Metal Hydride Standard-Charge

For applications which can allow a recharge period of about 16 hours — an “overnight” charge — the standard-charge regimen is the method of choice. The reasons for this include:

- Simplest charging algorithm.
- Least expensive charge termination techniques.
- Small power supply required to provide the charging current.
- Small charging circuit power components.
- Low overall charging system power dissipation.

A standard-charge is relatively straightforward to implement. In “cookbook” form, such a charge requires:

- Charging Current: 0.1C, switching to 0.025C trickle-charge.
- Required Charging Voltage: 1.60V/cell or greater, plus charger overhead.
- Charging Temperature Range: 0°C to 50°C.
- Charging Time: 16 hours.
- Charge Termination Method: Timer.
- Secondary Charge Termination Methods: None required.

- Special issues which may require further consideration are: wide temperature range discharging and accurate gas gauging at temperature extremes.

A charging current of 0.1C, fed to the battery for 16 hours, will deliver  $(16 \text{ hours} \times 0.1C) = 160\%$  of standard capacity to the battery. At temperatures between 0°C and 25°C, the resulting 60% overcharge is adequate to ensure that the battery is returned to 100% of its standard capacity. Once this has occurred the charging rate must be reduced sufficiently that cell venting does not occur. At the same time the 1%/day self-discharge of the NiMH cell needs to be countered with a suitable trickle-charge rate. The resulting two-level constant-current charger usually switches in a 0.025C rate after the 0.1C main charge. A NiMH battery will show a modest temperature increase (typically 8°C to 9°C) after 16 hours of standard-rate charging. However, this value is not tightly defined and the rate of temperature rise is quite gradual at the end of the charging cycle. This rules out thermal charge termination for the standard-charge regimen. A better approach is a timed-charge technique which applies the standard-rate charging current for 16 hours and then drops back to a 0.025C trickle-charge. A refinement to this is to break the main charging interval into numerous shorter intervals under the control of the timer internal to the LTC1325. In this way, even if the microprocessor controlling the battery system should “lock up,” permanent damage to the battery will be prevented. Charging at temperatures below 0°C or above 45°C is not recommended. In addition, NiMH batteries should not be discharged beyond the range of -20°C to 50°C. If a wide temperature excursion of the ambient is anticipated, the use of a thermal sensor in conjunction with the LTC1325 is an excellent way to ensure that battery operations occur only within their permissible temperature boundaries, which will significantly extend battery life.

The charge acceptance of NiMH batteries is reduced significantly at temperatures above 40°C. This effect should be taken into account if gas gauging is to be done over extended temperature ranges. In this regard, the performance of NiMH and Nickel-Cadmium batteries is quite similar. A NiMH battery that will recover 100% of standard capacity after 16 hours at 25°C will attain only about 85% of standard capacity at 45°C. Hence the battery’s available capacity during subsequent discharge will be less than

one would otherwise expect. If correction parameters for the gas gauging function of the LTC1325 will be employed, it is recommended that the manufacturer of the specific battery in question be consulted.

In the same way that charge acceptance is reduced for temperatures above 25°C, actual capacity is reduced when discharging a cell at temperatures much below 25°C. Typical figures for actual capacity are 85% of standard capacity at 0°C, and 50% at -20°C. Again, for more specific data the manufacturer of the battery to be used should be contacted.

Generally speaking, it's not a good idea to use a lower charging rate than 0.1C. This is due in part to the fact that NiMH cells have a reduced charge acceptance at lower charge rates, lengthening the required charge time, and in part to the fact that their self-discharge rate of approximately 1%/day at 23°C increases quickly with temperature.

### Nickel-Metal Hydride Fast-Charge

In recent years a class of applications has arisen for which 5 hours to 16 hours may constitute an excessive recharge time. NiMH batteries, with their relatively high energy densities, were perfected largely for the mobile portion of this market. Portable computer equipment is an excellent example of a NiMH fast-charge application — even if the battery pack in a laptop can be “swapped out” for external recharge, it is often needed again within several hours, fully charged and ready for use. In this case the techniques which the LTC1325 makes practical are the way to go. Such a fast-charge implies:

- 90% recharge within one hour; 100% recharge within two to four hours.
- A method for determining the optimum charge termination point(s).
- Backup charge termination method(s) to ensure best battery life.
- Highly efficient use of available charging energy.
- Increased product value through better battery utilization and greater customer satisfaction.

A fast-charge battery system involves:

- Charging Current: 1.0C.

- Charging Time: Three hours (90% of charge is typically returned within the first hour).
- Required Charging Voltage: 1.80V/cell or greater, plus charger overhead.
- Charging Temperature Range: 15°C to 30°C optimal (consult manufacturer for permissible range).
- Charge Termination Method: See Table A3.
- Secondary Charge Termination Methods: See Table A3.
- Special issues which may require further consideration are: accurate gas gauging at temperatures other than 25°C and appropriate mechanical integration of the battery pack into the end equipment.

The objective of fast-charging a NiMH battery is, crudely stated, to cram as much energy as it takes to bring the battery back to a fully charged state into that battery in as short a time as possible. Since current is proportional to energy divided by time, the charging current should be as high as the battery system will reasonably allow. Generally, NiMH batteries are rated for a 1C maximum charging rate. At that rate, more than 90% of the useable discharge capacity of the battery is typically returned within the first hour. Of course, the LTC1325 will also support the charging of higher rate cells as they become available.

Fast-charging has compelling benefits, but places certain demands upon the battery system. A properly performed fast-charge can yield a cell life of as many as 500 charge/discharge cycles. The high charging rates involved, however, do engender correspondingly more rapid electrochemical reactions within the cell. Once the cell goes into overcharge, these reactions cause a rapid increase in internal cell pressure and in the cell's temperature. Figure A2 shows the Voltage and Temperature characteristics of a Nickel-Metal Hydride cell being charged at the 1C rate. It can be seen that, as the cell approaches 100% of capacity, the charging current must be reduced or terminated. Left unchecked, overcharge at the C rate will ultimately cause the cell's safety vent to open. This results in a loss of gaseous electrolyte to the ambient and a permanent diminution of cell capacity. Similarly, allowing the temperature of the cell to rise excessively will cause a degradation of the internal materials, again reducing cell life. The science of fast-charging is largely that of determining when the battery has achieved between 90% and 100% of its

# Application Note 64

**Table A3. Fast-Charge Termination Techniques for Nickel-Metal Hydride Batteries**

Voltage Cutoff (VCO)	Uses absolute cell voltage to determine the cell's state of charge. Not generally recommended for use in NiMH charging regimens.
Negative $\Delta V$ ( $-\Delta V$ )	Looks for the downward slope in cell voltage which a NiMH exhibits ( $\approx 5\text{mV}$ to $15\text{mV}$ ) upon entering overcharge. Common in NiMH applications due to its simplicity and reliability.
Zero $\Delta V$	Waits for the time when the voltage of cell under charge stops rising, and is "at the top of the curve" prior to the downslope seen in overcharge. Sometimes preferred over $-\Delta V$ , as it causes less overcharging, and may be easier to detect reliably (due to the small $-\Delta V$ of a NiMH cell). Common in NiMH applications.
Voltage Slope ( $dV/dt$ )	Looks for an increasing slope in cell voltage (positive $dV/dt$ ) which occurs somewhat before the cell reaches 100% returned charge (prior to the Zero $\Delta V$ point). Not widely used.
Inflection Point Cutoff ( $d^2V/dt^2$ , IPCO)	As a NiMH cell approaches full charge, the rate of its voltage rise begins to level off. This method looks for a zero or, more commonly, slightly negative value of the second derivative of cell voltage with respect to time.
Absolute Temperature Cutoff (TCO)	Uses the cell's case temperature (which will undergo a rapid rise as the cell enters high-rate overcharge) to determine when to terminate high-rate charging. A good backup method, but too susceptible to variations in ambient temperature conditions to make a good primary cutoff technique.
Incremental Temperature Cutoff ( $\Delta TCO$ )	Uses a specified increase of a NiMH cell's case temperature, relative to the ambient temperature, to determine when to terminate high-rate charging. A popular, relatively inexpensive and reliable cutoff method.
Delta Temperature/Delta Time ( $\Delta T/\Delta t$ )	Uses the rate of increase of a NiMH cell's case temperature to determine the point at which to terminate the high-rate charge. This technique is inexpensive and relatively reliable as long as the cell and its housing have been properly characterized.

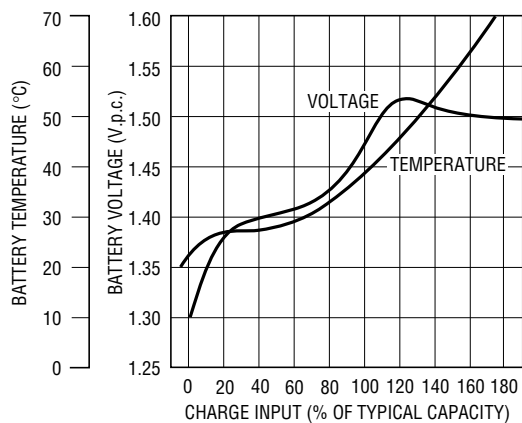

Data used courtesy of Duracell, Inc.

AN64 FA02

**Figure A2. NiMH Voltage and Temperature Characteristics During Charge at 1C (20°C Ambient)**

dischargeable capacity. At that point the charging circuit must switch from the fast-charge current level to a level appropriate to finish the charging of, and/or maintain the charge on the battery. Some of the common methods for doing this are outlined in Table A3.

As Table A3 shows there are a number of techniques which have been successfully employed for the purpose of determining when to terminate the high-rate interval of a fast-charge regimen. Individual application requirements, and manufacturer's recommendations, must of course be considered carefully before making a final design decision. Several techniques for detecting the point at which to make the transition from high-rate charging to top-charging have gained especially wide acceptance in the NiMH community. Among these are the  $\Delta T/\Delta t$ , the  $\Delta TCO$ , the  $-\Delta V$ , and the  $d^2V/dt^2$  methods.  $\Delta T/\Delta t$  sensing measures the rate of change of the case temperature of the cell, or of a cell in the battery with respect to time. When this rate of rise reaches  $1^\circ\text{C}/\text{minute}$ , almost all of the dischargeable capacity has been returned to the cell and the high-rate charge should be terminated.  $\Delta TCO$  sensing measures the difference between the case temperature of the cell, or of one of the cells in a battery, while also measuring the ambient temperature. A  $15^\circ\text{C}$  differential between cell and ambient is the typical high-rate termination criterion. The  $-\Delta V$  approach looks for a point at which

the cell or battery voltage peaks during charging, and holds this maximum value. The high-rate charge is then terminated when the voltage per cell has declined by a value of 5mV to 10mV. The  $d^2V/dt^2$  technique looks for a slowing rate of rise in the the battery's terminal voltage. This trend, properly filtered and processed by the system's software, will yield a negative second derivative of battery voltage when the battery approaches a complete recharge. **It is important to note that under certain conditions, particularly following intervals of storage, a NiMH battery may give an erroneous voltage peak as charging commences. For this reason, a reliable fast-charge cycle should deliberately disable any voltage-based sensing technique for the first five minutes of the charging interval.**

For illustration of the fast-charging of NiMH batteries, this document will use the regimen recommended by Duracell, Inc. The three stages of this regimen are:

- Fast-charge at the **1C** rate, until it is determined by the charging system that the high-rate portion of the charging cycle must be terminated. At this point, a **1C** charge will typically have returned between 90% and 95% of the battery's actual capacity.
- Top-charge at **0.1C** for one hour to add an additional **0.1C** to the battery. This will bring the battery back to 100% of usable capacity.
- Trickle-charge at **0.0033C** to counter the self-discharge characteristic of Nickel-Metal Hydride, while not exposing the battery to excessive overcharge.

Nickel-Metal Hydride batteries suffer quickly and severely from protracted overcharge. To prevent damage to the battery all manufacturer's algorithms recommend a low trickle-charge value. As shown, Duracell recommends **0.0033C** while many other vendors specify **0.025C**. The exact value of this trickle-charge, as well as the specific overall charging regimen, is application and vendor dependent, so the literature of the selected battery supplier should be consulted.

It cannot be overstated that the high-rate portion of a fast-charge regimen must be terminated once the battery being charged has reached the appropriate cutoff point. Murphy has taught us to prepare for the unexpected. So for each method consider: "How can the this method fail?" To

illustrate by example: contact resistance in the charging path could mask the downslope of the battery's terminal voltage, causing the microprocessor to miss the  $-\Delta V$  termination point. For the case of  $\Delta T/\Delta t$  termination, the ambient temperature might artificially prevent a rapid enough change in temperature from occurring (e.g., re-charging of a battery while it sits in the airstream of an air conditioner). Failure of the charger system to recognize the cutoff point, for whatever reason, can quickly and irretrievably damage the battery. To avoid such damage, inexpensive redundancy is the solution. With the capabilities of the LTC1325 already at hand, the best plan is to simply employ two or more methods. It is then reasonable to expect that one of the techniques will result in a successful high-rate charge termination. In Duracell's suggested regimen the primary technique for terminating the high-rate charge is  $\Delta T/\Delta t$  sensing, with  $-\Delta V$  serving as a backup. To give Murphy's gremlins a harder time of it, there are maximum and minimum operating temperatures and cell voltages which the LTC1325 can be set to recognize. For example, Duracell recommends using a third, TCO-based "safety" to shut the high-rate charge down if the battery temperature ever exceeds 60°C absolute. The LTC1325 also has a timer feature which will turn off the charge current to the battery unless the timer is reset within a certain interval. Not only does this provide an extra margin of safety, it can simplify charging as well: Duracell's regimen calls for one hour of timer-controlled **0.1C** over-charge. The LTC1325 can offload this timing job from the system processor. Hence, the battery charging task is simplified and the battery is protected from severe over-charge even if the system's microprocessor should fail altogether.

As mentioned above, fast-charge current levels can cause rapid gas evolution within a NiMH cell. Since gas recombination inside the cell is slower at reduced temperatures, the pressure inside the cell will rise as the cell temperature decreases. This places a lower limit on the permissible fast-charge temperature range. Similarly, the cell's charge acceptance decreases at elevated temperatures. Hence, although gas recombination occurs much more rapidly, there is the danger of more gas being generated than the cell mechanisms can handle. This places an upper boundary on the fast-charge temperature range. Putting numbers to these limits, 10°C to 15°C are common minimum

## Application Note 64

---

figures with the high end at 40°C to 45°C. This temperature span constitutes the limit for fast-charging of NiMH batteries; they will give longer life and better performance if charged between 15°C and 30°C. Using the LTC1325's measurement capabilities to ensure that the indicated operations occur within the manufacturer's rated temperature limits will significantly extend the life of the cell or battery.

For the most accurate gas gauging, it may be desirable to take into account the battery's actual temperature during charge and its temperature during discharge. Both of these have an effect upon the ratio of actual capacity to standard capacity. This effect may be especially pronounced if the battery is charged at an ambient temperature above 25°C and/or discharged at 0°C or below. For specific data with which to calibrate the gas gauge function against charge and discharge temperatures, the manufacturer of the cells or batteries being used should be contacted.

During fast-charge the battery will get warm and may vent in the unlikely case of overstress or failure. It is prudent engineering to allow for these contingencies in the mechanical design stage of the equipment in which the battery will reside. Again, the manufacturer of the cells or battery to be used should be consulted for specific guidance.

### Using Sealed Lead-Acid Batteries

Lead-Acid batteries are the "venerable elders" among rechargeable power sources. They have been known in various forms for substantially over a century. But age does not imply weakness—many of the most significant developments in Lead-Acid cells, including those which have made the portable Sealed Lead-Acid (SLA) construction practical, have taken place in the last 30 years or less. Concerns about the safety and stability of the sulfuric-acid electrolyte system have been addressed, first by the well-known "Gel Cell," and thereafter by modern "starved-electrolyte" technologies. Improvements in the purity of materials, and the optimization of the internal cell structure for portable battery applications (as opposed to the traditional automotive market which imposes its own unique demands) have made the SLA battery a serious contender for many applications. In the smaller ratings

SLA batteries compare favorably in cost per Watt-Hour with NiCd batteries and are superior to NiMH devices; in higher Watt-Hour ratings SLA technology is usually the clear choice. With a minimum of board space and system overhead, the LTC1325 provides a programmable switch-mode charging controller. It also carries on-chip all necessary battery monitoring and safeguard circuitry, and the means to readily implement gas gauge algorithms.

A quick rundown of the pros and cons of Sealed Lead-Acid batteries:

The "pros":

- The electrochemistry and electrical behavior of SLA batteries are very well understood and documented for moderate charge rates and for a broad range of discharge rates.
- SLA technology lends itself to prismatic batteries as well as cylindrical cells.
- SLA batteries are available with wider operating temperature ranges than either NiCd or NiMH batteries.
- Excellent cost/Watt-Hour, especially in larger size cells and batteries.
- Very low self-discharge rates:  $\approx 0.2\%/day$  at 25°C
- Low cell impedance with a good capability to handle high pulse currents.
- SLA cells are available in a variety of sizes from a number of vendors.

The "cons":

- The SLA cell has the lowest energy density, by weight and by volume, of all three technologies.
  - SLA batteries deliver their best performance under a constant voltage (or pseudo-constant voltage) charge regime.
  - Lead is commonly considered to be an environmentally hazardous material.
  - SLA cells are susceptible to damage from overcharge, repeated deep discharge, and/or cell reversal.
  - The discharge profile of a SLA cell is not as flat as that of a NiCd cell, nor as that of an NiMH cell in most applications.
-

### Sealed Lead-Acid Standard-Charge

For applications which can allow a recharge period of 24 hours or more — any period from an extended “overnight” charge to a “float charge” — the standard-charge is the regimen of choice. The reasons for this include:

- No charge termination required.
- Frequently requires no temperature compensation.
- Small power supply required to provide the charging current.
- Small charging circuit power components.
- Low overall charging system power dissipation.
- Excellent battery life due to low charging stress.

An SLA standard-charge is relatively straightforward to implement. In “cookbook” form, such a charge requires:

- Charging Current: Limited to 0.25C or less.
- Charging Voltage: 2.25V/cell to 2.30V/cell, plus charger overhead.
- Charging Temperature Range: 0°C to 40°C.
- Charging Time: 24 hours or longer.
- Charge Termination Method: None required.
- Secondary Charge Termination Methods: None required.
- Special issues which may require further consideration are: wide temperature range charging, wide temperature range discharging, and accurate gas gauging under varying conditions of use.

Sealed Lead-Acid (SLA) batteries are generally charged using a constant voltage source with a deliberately imposed current limit (essentially a current-limited voltage regulator), or a charger which will, in terms of the electrochemical effects seen by the battery, act as if it were such a source. The charging regimen which this gives rise to is known as “Constant Voltage,” or more commonly, “Constant Potential.” For the purposes of this document the term “Constant Potential” (CP) will be used.

The reasons for using a CP charge regimen are various, but the three principal ones are these:

- Charge acceptance (the efficiency of conversion of previously removed electrical energy back into chemi-

cal potential) is reduced as the charging current through an SLA cell is increased.

- Once full charge is achieved, continued charging current through an SLA cell will have an irreversible oxidizing effect upon the positive plate of the battery, ultimately reducing battery capacity.
- Most importantly from the standpoint of designing a practical charger, there is no reliable way to know an SLA cell’s state of charge based upon its terminal voltage or its temperature.

A significantly discharged cell undergoing CP charging will initially attempt to draw very high currents, as SLA cells are low impedance devices. The function of the current-limiting in the CP regimen is to keep the peak current flowing into the cell within the cell’s (and the charger’s) ratings. Following the current-limited phase of the charging profile, the CP charging technique in combination with the characteristics of SLA devices cause the cell under charge to in essence regulate its own charging current. If the cell vendor’s recommendation as to charging voltage (typically 2.25V/cell to 2.30V/cell at 20°C) are followed, the cell’s charging current will naturally taper off with time as the cell goes slightly into overcharge. Under these conditions a fully discharged cell will essentially cease charging once it has achieved a 110% returned charge which results in a 100% dischargeable capacity. The remaining 10% is lost to heating and other parasitic reactions. This simple charging concept, sometimes combined with compensation for ambient temperature (–2mV/°C to –3mV/°C, depending upon the manufacturer), will provide highly satisfactory results over a good temperature range. A range of 0°C to 40°C is typical, with some vendors specifying their products for operation at temperatures of 50°C or more. Figure A3 shows the way in which SLA charge current tapers off and the returned capacity rises under such a CP charging regimen. Figure A4, a reproduction of Figure 10 from the body of this Application Note, shows how the LTC1325 can be used to provide all the necessary functions for SLA battery management. As in the body of this Application Note, Figures B3a and B3b in Appendix B are also relevant here.

The charge acceptance of SLA batteries is reduced at temperatures below about 0°C, and actual capacity is reduced when discharging a cell at temperatures much

# Application Note 64

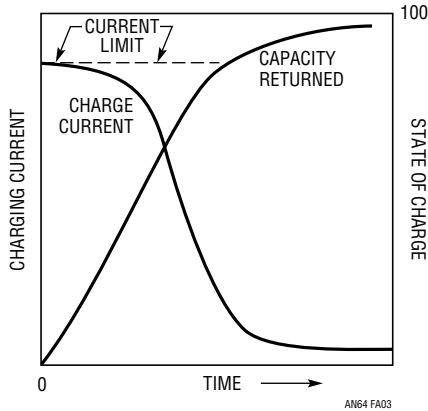

Reproduced with permission by Butterworth-Heinemann, *Rechargeable Batteries Applications Handbook*, copyright 1992

**Figure A3. Typical Charging Current and Capacity Returned vs Charge Time for CP Charging**

lower than 25°C. The battery temperature at which actual capacity is 85% of standard capacity is approximately 0°C. Similarly, adjustment to the indicated capacity may be desired if the continuous discharge current will be at a rate significantly greater than 0.1C. It may be desirable to take these effects into account if gas gauging is to be done over extended temperature ranges. If correction parameters for

the gas gauging function of the LTC1325 will be employed, it is recommended that the manufacturer of the specific battery in question be consulted.

Under some conditions, it may be desirable to use a lower charging rate than 0.1C (for instance, to reduce charger power requirements). This is quite feasible with SLA batteries due to their low self-discharge rates. SLA batteries have excellent charge acceptance characteristics at lower charge rates. Ultimately, the limiting issue is usually the maximum practical time allowable for a recharge.

During charging, the battery may get warm and/or vent. It is prudent engineering to allow for these contingencies in the mechanical design stage of the equipment in which the battery will reside. The manufacturer of the SLA battery to be used should be consulted for specific guidance.

## Sealed Lead-Acid Fast-Charge

In many cases, 24 hours or more will constitute an excessive recharge time. Portable instrumentation is an excellent example—even if the battery pack in an instrument can be “swapped out” for external recharge, it is often needed again before the day is out, fully charged and

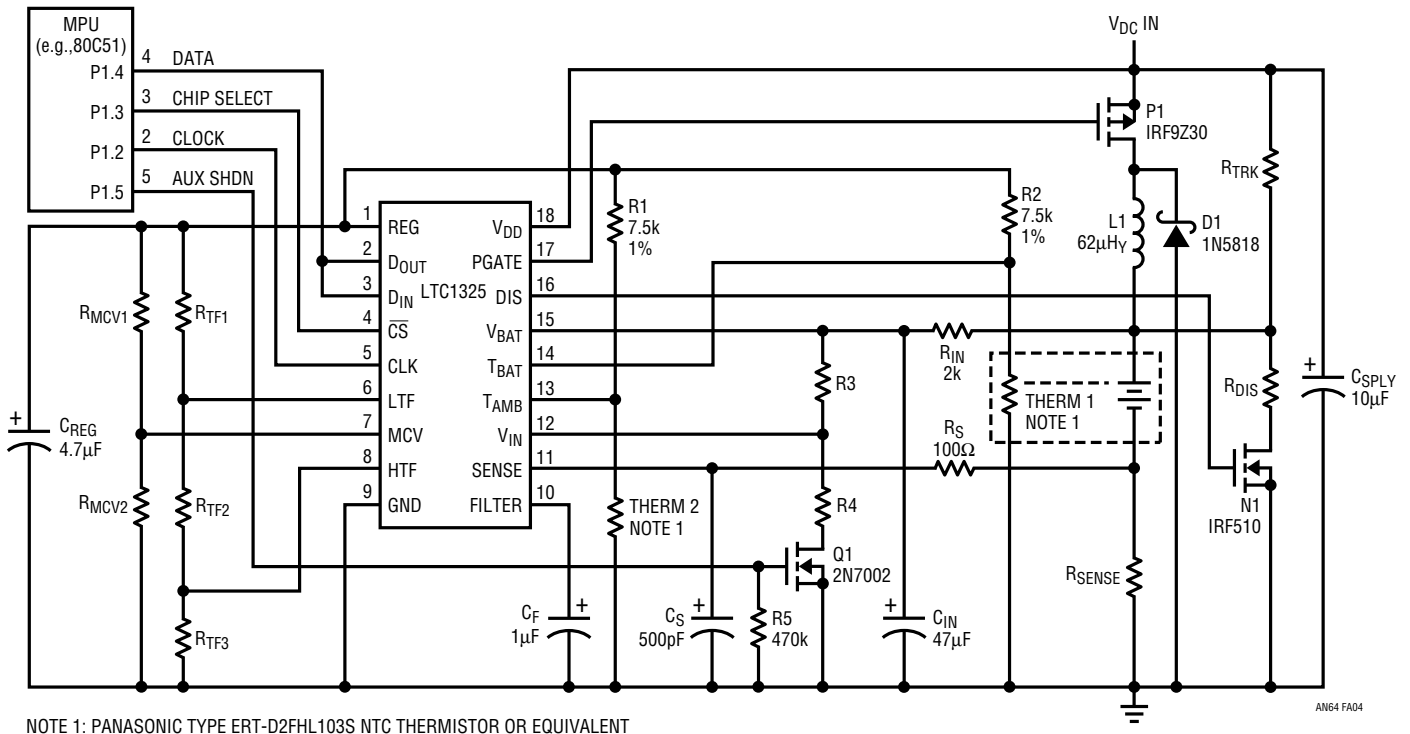

NOTE 1: PANASONIC TYPE ERT-D2FHL103S NTC THERMISTOR OR EQUIVALENT

**Figure A4. LTC1325 Constant Potential Battery Management System**

ready for use. In this case the sophisticated fast-charge techniques which the LTC1325 makes practical are the way to go. A fast-charge regimen implies:

- Significant recharge within one hour; 100% recharge within three hours.
- Suitable means to determine charge termination point.
- A backup charge termination method to ensure best battery life.
- Highly efficient use of available charging energy.
- Increased product value through better battery utilization and greater customer satisfaction.

An SLA fast-charge is very similar to an SLA standard-charge. It is recommended that the section on standard-charging of Sealed Lead-Acid batteries be read before reading this section. There are only three significant differences between the two sections:

- a) The charging voltage is increased (to increase the charging current).
  - b) Temperature compensation is definitely required at a rate of  $\approx -5\text{mV}/^\circ\text{C}$ , preferably from a sensor mounted near or on the battery case.
  - c) Fast-charge termination is required.
- Charging Current: Vendor-dependent. The vendor used as a reference suggests  $1.5\text{C}$ .
  - Charging Voltage:  $2.45\text{V}/\text{cell}$  to  $2.50\text{V}/\text{cell}$ , plus charger overhead.
  - Charging Temperature Range:  $0^\circ\text{C}$  to  $30^\circ\text{C}$ .
  - Charge Termination Method: Current Cutoff.
  - Charging Time: Three hours; 60% of charge is typically returned within the first hour.
  - Secondary Charge Termination Methods: Timer.
  - Special issues which may require further consideration are: wide temperature range charging, wide temperature range discharging, and accurate gas gauging under varying conditions of use.

The primary termination method, “Current Cutoff” (CCO), looks at the absolute value of the average charging current flowing into the battery. When that current drops below  $0.01\text{C}$  the battery is charged and needs only a trickle

current of about  $0.002\text{C}$ . The backup method should be a 180-minute time-out, according to the recommendations of the vendor suggesting  $1.5\text{C}$  as a high-rate current.

During fast-charge the battery will get warm and some venting may occur. It is prudent engineering to allow for these contingencies in the mechanical design stage of the equipment in which the battery will reside. The manufacturer of the SLA battery to be used should be consulted for specific guidance.

In all other regards, the techniques for the fast-charging of SLA cells and batteries are the same as those used for standard-charging these devices. A simple circuit, coupled with a straightforward software servo loop, provides a high performance SLA battery charger and gas gauge as well as significant built-in fault detection and protection mechanisms.

### Using Lithium-Ion Batteries

Of the four battery types discussed in this Appendix, Lithium-Ion (Li-Ion) is the newest. Li-Ion cells offer excellent service life, are considered environmentally sound, are easily manufactured in true prismatic (rectangular) format, and most importantly, they have the highest energy density, both in terms of Watt-Hours/kg and Watt-Hours/Liter, of any of the cells discussed.

By merely telling the associated microcontroller whether a NiMH or a Li-Ion battery is present in the system, the LTC1325 using the same hardware can accommodate either type of cell technology.

Li-Ion batteries are charged using a constant voltage source with a deliberately imposed current limit (essentially a current-limited voltage regulator), or a charger which will, in terms of the electrochemical effects seen by the battery, act as if it were such a source. The charging regimen which this gives rise to is known as “Constant Voltage,” or more commonly, “Constant Potential.” For the purpose of this document, the term “Constant Potential” (CP) will be used.

A quick run-down of the pros and cons of Lithium-Ion batteries:

The “pros”:

- Superb energy densities, both by Watt-Hours/Liter and Watt-Hours/kg, relative to competing technologies.
-

# Application Note 64

---

- High average cell voltage during discharge (3.6V).
- Excellent cycle life characteristics.
- Very low self-discharge rates ( $\approx 0.3\%/day$  at  $25^{\circ}\text{C}$ ).
- Environmentally sound (not a heavy-metal technology).
- Li-Ion cells are available in prismatic (rectangular) form factors.

The “cons”:

- Susceptible to irreversible damage if taken into deep discharge.
- Susceptible to loss of capacity or catastrophic failure if overcharged.
- Efficient use of cell capacity requires extremely tight control of charging voltage.

## Lithium-Ion Fast-Charging

An Li-Ion fast-charge is conceptually quite simple:

- Charging Current: **1C**.
- Charging Voltage:  $4.20\text{V} \pm 0.05\text{V}$  (some cells require slightly different voltages)
- Charging Temperature Range:  $0^{\circ}\text{C}$  to  $40^{\circ}\text{C}$ .
- Charging Time: 2.5 Hours to 5 Hours.
- Charge Termination Method: A timer is typical (consult cell manufacturer).
- Secondary Charge Termination Methods: None required.
- Special issues which require further consideration are: wide temperature range charging, wide temperature range discharging, and accurate gas gauging under varying conditions of use.

A significantly discharged cell undergoing CP charging will initially attempt to draw very high currents, as Li-Ion cells are relatively low impedance devices. The function of the current-limiting in the CP regimen is to keep the peak current flowing into the cell within the cell’s (and the charger’s) ratings. Following the current-limited phase of the charging profile, the CP charging technique in combination with the characteristics of the Li-Ion cell cause the cell under charge to in essence regulate its own charging

current. If the cell vendor’s recommendation as to charging voltage (usually  $4.20\text{V} \pm 50\text{mV}$  at  $23^{\circ}\text{C}$ ) are followed, the cell’s charging current will naturally taper off with time. Figure A3 illustrates such charging behavior. This straightforward charging regimen is, to our best knowledge, all that is required to charge one cell. Multicell Li-Ion battery packs (e.g., two or more cells in series) incorporate a custom circuit for monitoring the state of charge of each individual cell within the battery. This circuit also provides extensive overcharge and other major fault protection.

The LTC1325 can readily charge either a single cell, or a manufacturer’s finished battery pack. The LTC1325 is, at first glance, a constant-current part. Such a view of its capabilities, however, is too limited. Its power control section is more completely described as a constant-average-current PWM, with the capability for “software” feedback. Given a suitable output filter (probably only the output inductor and the battery itself), the current from the PWM section can be turned into a suitably constant voltage at the battery’s terminals and this voltage used to charge Li-Ion cells or batteries.

The software feedback loop mentioned previously allows the controlling processor to handle all aspects of charging, rather than demanding that important variables be hardwired. The necessary CP servo loop is created as follows:

- Establish a regular repetition interval for the voltage servo loop. 10ms to 20ms gives good results for sealed lead-acid and Li-Ion cells and batteries.
- Set  $V_{\text{DAC}}$  to 150mV for best resolution.  $R_{\text{SENSE}}$  is then chosen as  $150\text{mV}/(0.9 \cdot I_{\text{MAX}})$ , where  $I_{\text{MAX}}$  is the maximum current to be allowed through the battery.
- Perform each of the following tasks once each servo loop interval:
  - a) Enter Idle mode of operation.
  - b) Each  $V_{\text{CELL}}$ .
  - c) Adjust the value entered into a timer register (or a software timer) up or down according to actual  $V_{\text{CELL}}$  vs target  $V_{\text{CELL}}$ . If  $V_{\text{CELL}}$  is too high the timer value is increased. If  $V_{\text{CELL}}$  is too low the timer value is decreased.

- d) Assume that the maximum  $t_{ON}$  of the charger will be 90% of each servo loop interval.
- e) Enter Charge mode of operation, for a period of between 90% and 20% of the servo loop interval [as determined by (d)]. In essence, the timer's period is being subtracted from the charging time available during each servo loop interval, to perform a duty cycle modulation via the processor.
- f) If  $t_{ON} < 2ms$ , switch  $V_{DAC}$  to the next lower value.
- g) Repeat (a) through (f) until the current into the battery drops below  $0.002C$ , or until three hours of charging have elapsed.
- h) Terminate the software loop with the MOSFET P1 (Figure A4) in the "off" state. No trick-charging resistor is used.

### Lithium-Ion System Issues

Lithium-Ion cells and batteries require tight control over the voltages to which they are exposed. This makes it virtually mandatory that precision external resistive divider be used to scale the battery voltage and present it to the auxiliary ADC input  $V_{IN}$ . The highest input voltage possible consistent with not overloading the LTC1325's ADC should be used; 3.000V full-scale is a good choice.

This gives the best ADC resolution and helps preserve the accuracy of the part when measuring battery voltage. If the LTC1325's internal battery divider is used, account must be taken of its tolerance ( $\pm 2\%$ ), as well as the reference tolerance ( $\pm 0.8\%$ ) and the ADC tolerances (4 bits/1024 bits = 0.4%). The system tolerance then is  $\pm 3.2\%$ . Adding in a  $\pm 1\%$  resistor division ratio would bring this tolerance to  $\pm 4.2\%$ .

Using a  $\pm 0.1\%$  external divider feeding into the  $V_{IN}$  pin, the resulting tolerance is the  $\pm 0.8\%$  of the reference, plus the  $\pm 0.5\%$  represented by the ADC and the divider resistors. The design center charging voltage is 4.19V. Overcharging (an effective voltage at the battery's terminals of greater than 4.250V absolute maximum) is strongly discouraged by Li-Ion cell manufacturers. Any overcharging will shorten the cell's life and may result in catastrophic failure. With the undivided battery voltage connected to the LTC1325's  $V_{BAT}$  input, the on-chip battery divider can be used to check for  $V_{CELL}$  reaching the FEDV (Fault: End of Discharge Voltage) point.

There is also a need to ensure that the cell voltage rarely, if ever, dips below 2.5V to 2.7V (contact the specific cell manufacturer for details), and that it *never* goes below 1.0V. This is a spot where the fail-safe capabilities of the LTC1325 can serve the Li-Ion user well.

# Application Note 64

## APPENDIX B

### Flow Charts

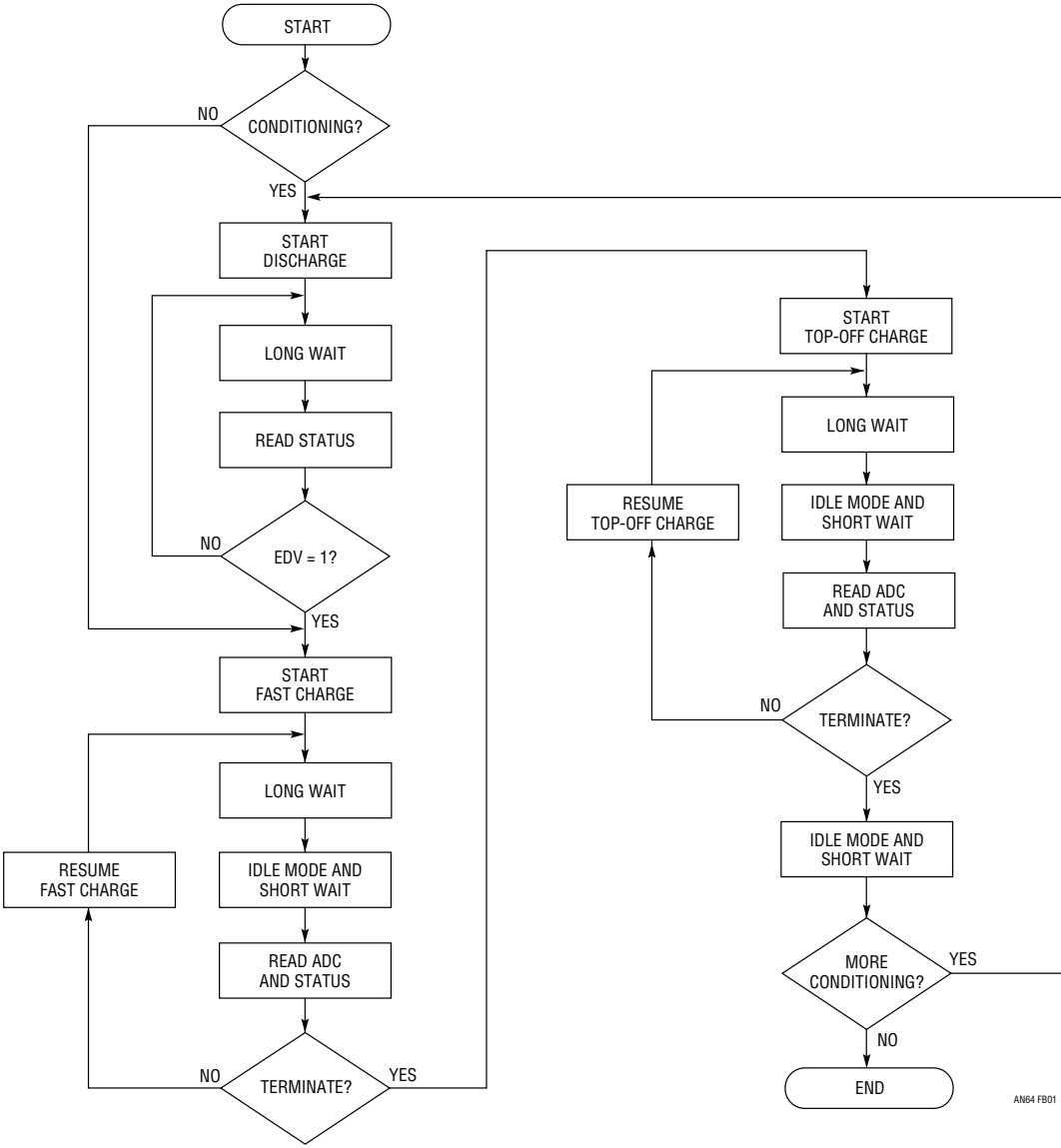
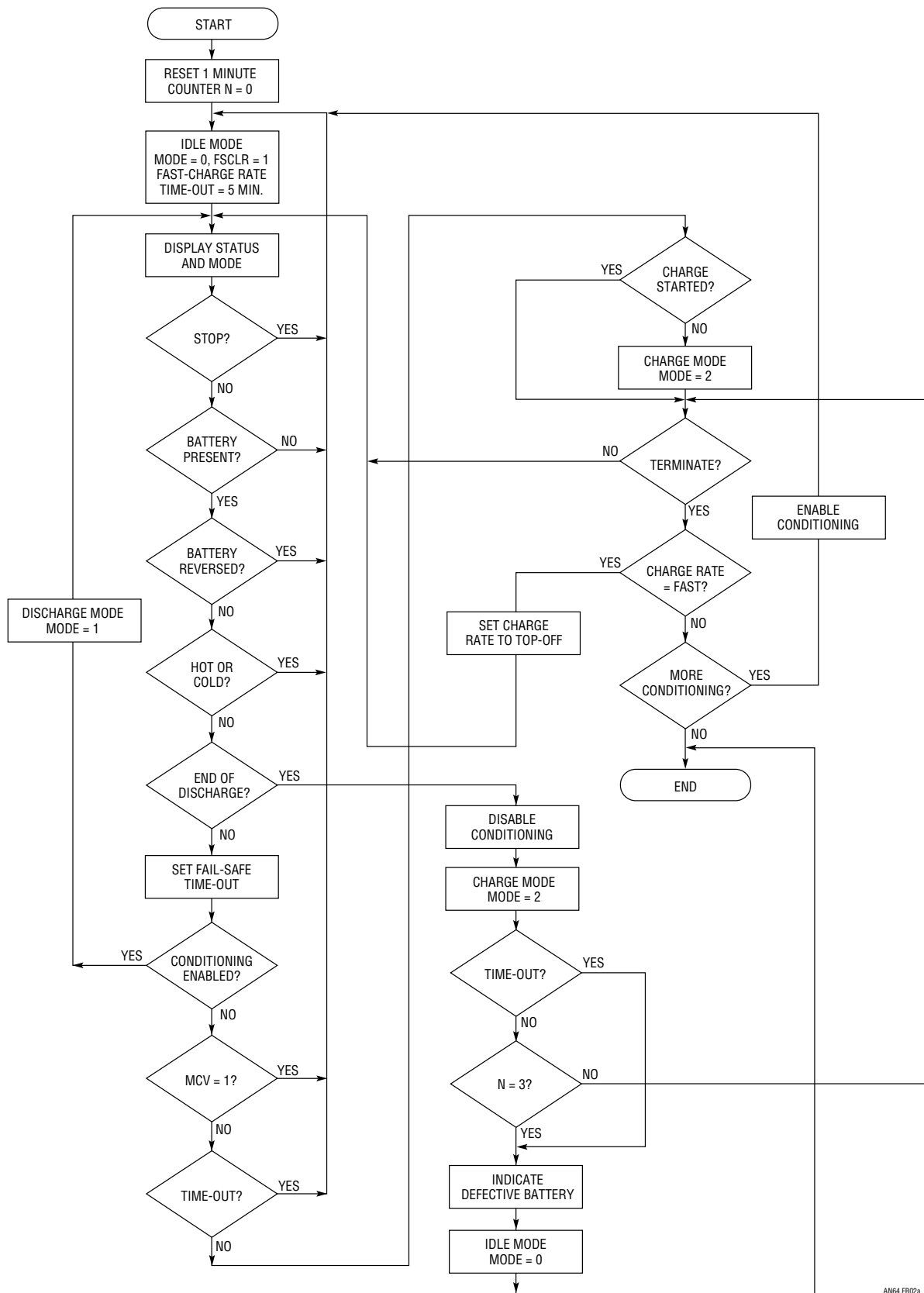

Figure B1. Simplified Battery Management Flow Chart



AN64 FB02a

Figure B2a. Comprehensive Battery Management Flow Chart

# Application Note 64

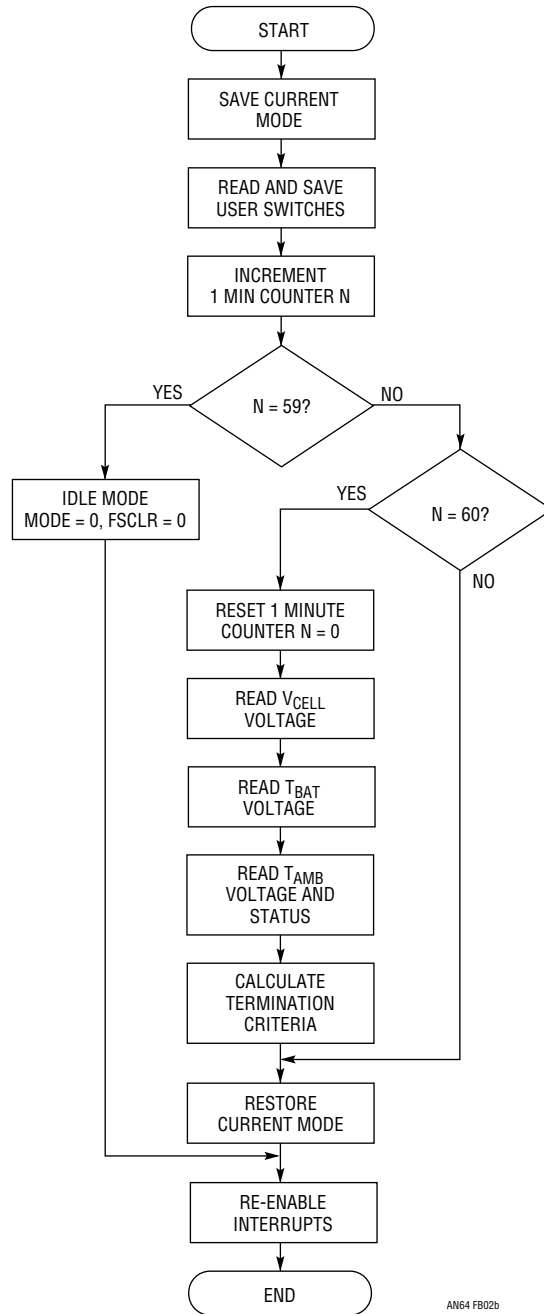

AN64 FB02b

Figure B2b. Timer Interrupt Service Routine for Comprehensive Battery Management

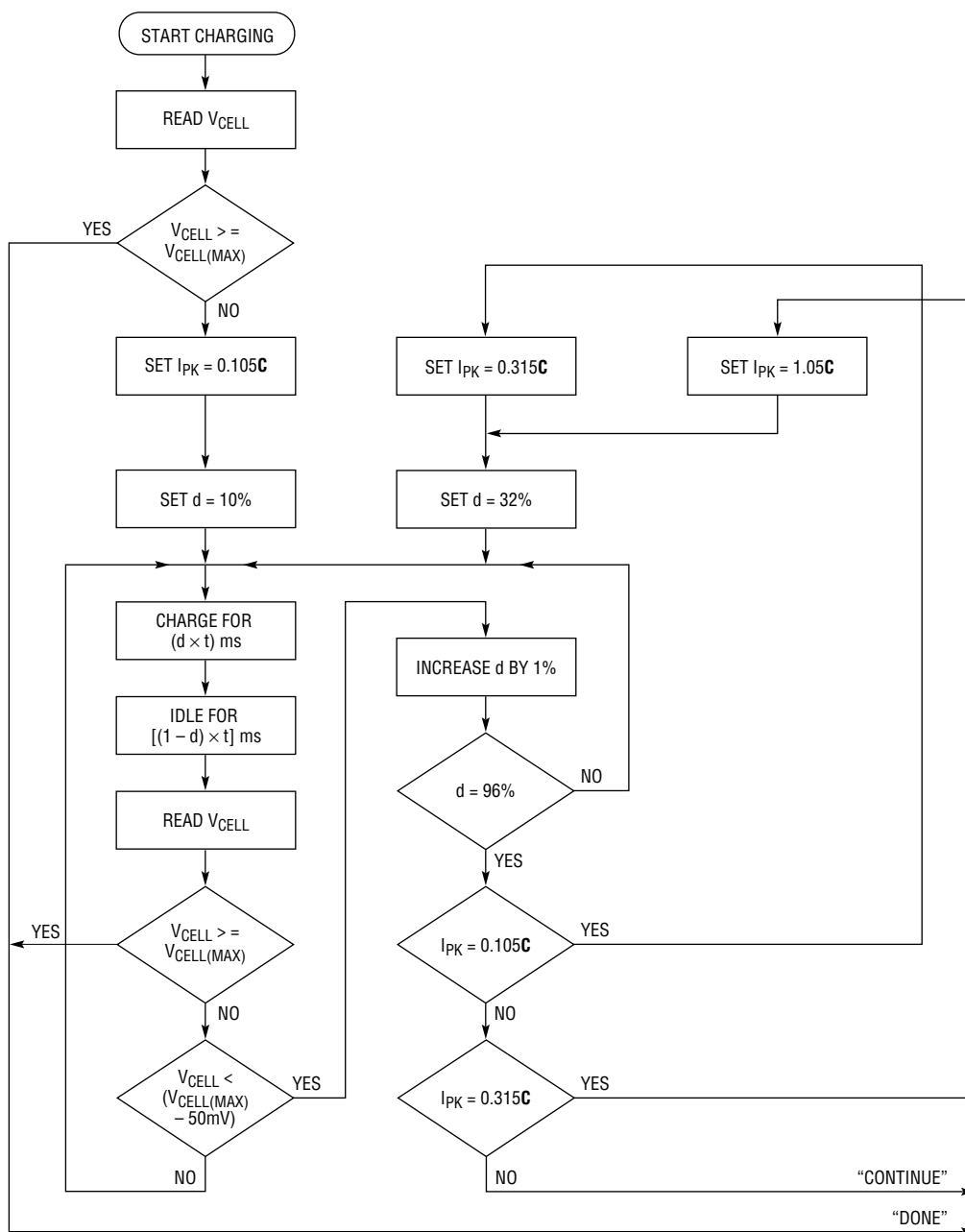

AN64 FB03a

Figure B3a. Constant-Potential Charging Algorithm for Lead-Acid and Li-Ion (1 of 2)

# Application Note 64

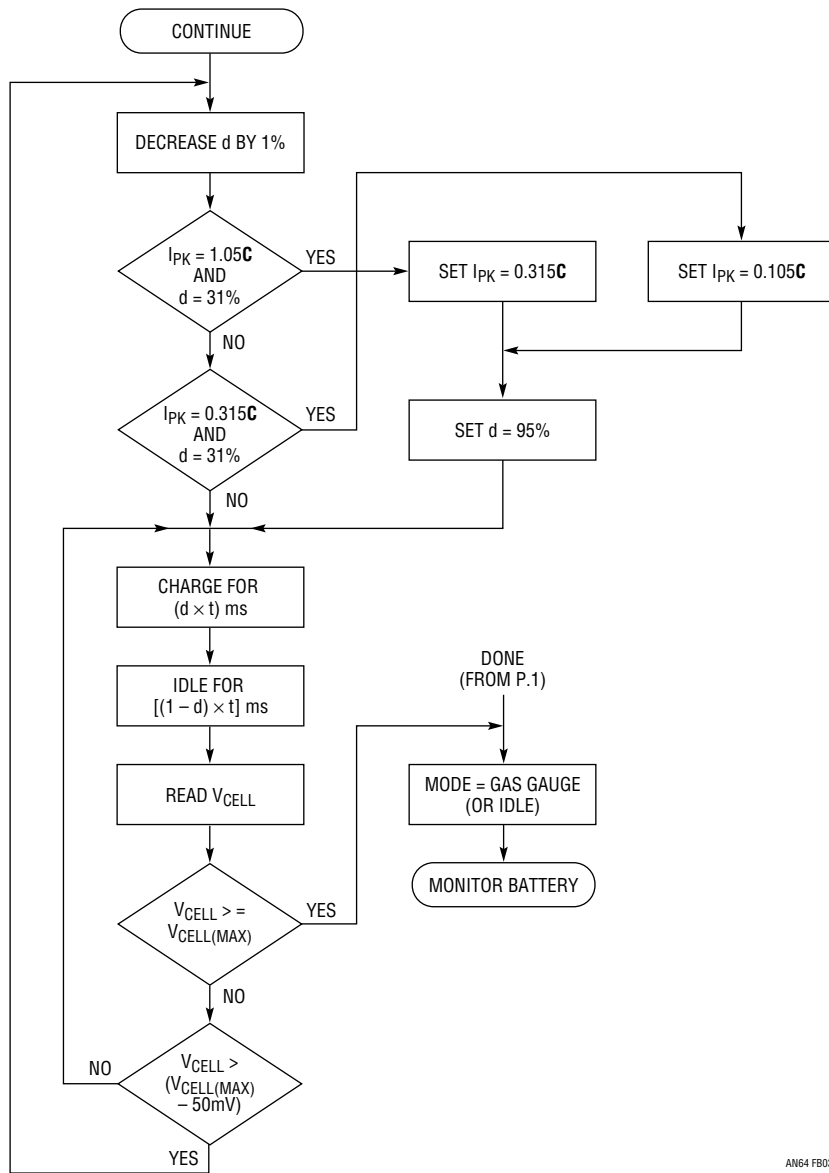

AN64 FB03b

Figure B3b. Constant-Potential Charging Algorithm for Lead-Acid and Li-Ion (2 of 2)

## APPENDIX C

### A Brief Glossary

As with any other field, rechargeable battery technique has its own terminology. Here are a few definitions which are useful to know. Also included are terms used to describe the LTC1325, its operation and the application circuits.

**Actual Capacity:** The capacity for electrical energy storage of a cell which is in good condition, under test circumstances which differ from those established for the measurement of the cell's standard capacity.

**Battery:** A grouping of cells, to increase the voltage (series), the Ampere-Hour capability (parallel), or both (series-parallel). In this document, "battery" may be used interchangeably with "cell." Where the two differ, the battery is assumed to be a series assembly of cells unless otherwise specified.

**Battery Divider:** A programmable voltage divider (divide by 1,2,...,16) connected between the  $V_{BAT}$  and Sense pins of the LTC1325. For battery types with per cell voltages of greater than 2.9V, it is necessary to program the divider to keep the divider output within the 2.9V minimum range of the LTC1325 10-bit ADC (Analog-to-Digital Converter).

**BATP:** Battery Present Status Bit. One of the status bits that the LTC1325 provides. This bit is set when the  $V_{BAT}$  pin is pulled below  $V_{DD}$  by at least 1.8V.

**BATR:** Battery Reversed or Battery Shorted Status Bit. One of the status bits that the LTC1325 provides. When the cell voltage,  $V_{CELL}$  is less than 100mV, the BATR bit is set and discharging or charging is terminated.

**C:** Current expressed in terms of the **C** rate of a battery, e.g., 1.2**C**, 0.1**C**, 2**C**, etc.

**C Rate:** A normalization concept widely used in the battery community. A **C** rate of unity is equal to the capacity of a cell in ampere-hours, divided by one hour. Hence a 2.4 Ampere-Hour cell has a **C** rate of (2.4 Ampere-Hours)/(1 Hour) = 2.4 Amperes. By extension, the 0.1**C** rate for the same cell equates to (0.1) (2.4 Ampere-Hours)/(1 Hour) = 0.24 Amperes, and the 2**C** rate is 4.8 Amperes. The value of this term lies in the fact that, for a given cell type, the behavior of cells of varying actual capacity will nonetheless be very similar at the same **C** rates.

**Cell:** A single electrochemical energy storage element. Cells come in various technologies (e.g., Nickel-Cadmium and Nickel-Metal Hydride) and in various Ampere-Hour ratings.

**Cell Reversal:** A situation involving the lowest capacity cell in a battery stack, which can manifest itself as the battery stack approaches a deeply discharged state. If a given cell reaches the condition of zero charge before the current draw from the battery stack as a whole is terminated, then current from other cells in the battery stack will force a net reverse charge onto the cell in question. This reverse charge, if allowed to continue for a significant length of time, can cause irreversible deterioration of the cell undergoing reversal.

**Charge Acceptance:** The ability of a battery to transform charging energy (in the form of electrical current) into available energy (in the form of useful chemical reactions). Essentially, a measure of the efficiency of the battery as a storage device for electrical energy. This efficiency varies with battery temperature, state of charge, charging rate, age and electrochemistry.

**Charge Mode:** The LTC1325 can be programmed into this functional mode to charge batteries. Charging will not commence or is terminated if the battery is absent (see BATP) or the battery temperature is outside permissible limits (see LTF and HTF) or the battery is reversed or shorted (see BATR) or if a time-out condition exists.

**Charge Termination Method:** The means employed by a given charging algorithm to determine the appropriate point in the charging cycle at which to terminate (a phase of) that charging cycle.

**Current Cutoff (CCO):** A charge termination technique which monitors the current level flowing into a cell or battery, and indicates to the charging circuit that the charging current should be reduced or cut off when the level falls below a given limit.

**Cycle Life:** The number of charge/discharge cycles which a battery can sustain before its capacity declines to a specified percentage of its standard capacity, or its initial actual capacity in a given application. The permissible percentage of loss of battery capacity is not a fixed term

## Application Note 64

---

within the battery industry, as most applications have their own unique criteria.

**dT<sub>BAT</sub>/dt:** See Delta Temperature/Delta Time.

**Delta Temperature/Delta Time ( $\Delta T/\Delta t$  or  $dT_{BAT}/dt$ ):** A Charge Termination Method (or Secondary Charge Termination Method) used to terminate the high-rate portion of a NiCd or NiMH fast-charge regimen. This technique makes use of the fact that the case temperature of a cell undergoing high-rate charge will experience a relatively rapid temperature rise as it goes into high-rate overcharge. When this rate of rise reaches a predetermined value (typically about 1°C/minute), almost all of the dischargeable capacity has been returned to the cell, and the high-rate charge should be terminated.

**d<sup>2</sup>V<sub>BAT</sub>/dt<sup>2</sup>:** See Inflection Point Cutoff.

**Discharge Mode:** The LTC1325 can be programmed into this functional mode to discharge batteries through an external limiting resistor R<sub>DIS</sub> and N-channel MOSFET. The gate of the N-channel MOSFET is driven by the DIS pin.

**Discharge Profile:** The voltage-vs-remaining charge characteristic of a cell or battery; the degree of voltage change shown by the battery as it goes from being fully charged to being fully discharged.

**Duty Cycle:** The LTC1325 can be programmed to modulate the “on” time of the charge loop with duty cycles of 1/16, 1/8, 1/4, 1/2 and 1. The period of this modulation is 42s.

**EDV:** End of Discharge Voltage. Refers either to the EDV status bit or to the internal end of discharge voltage of 0.9V. Discharge is automatically terminated by the LTC1325 when the cell voltage (V<sub>CELL</sub>) falls below 0.9V.

**Energy Density (W-H/kg):** A “figure-of-merit” term for comparing differing battery technologies in terms of energy storage capacity vs mass (Watt-Hours/kg).

**Energy Density (W-H/L):** A “figure-of-merit” term for comparing differing battery technologies in terms of energy storage capacity vs. volume (Watt-Hours/Liter).

**Fail-Safes:** Various protective measures (voltage, temperature and time limits) built into the LTC1325 to protect the battery against potentially damaging voltage and temperature conditions when in charge or discharge modes. Also referred to as “Fault Protection.”

**Fast-Charge:** Generally, any of several charging regimens which is capable of completely recharging a battery within three hours or less. More importantly, such regimens can typically return at least 90% of the battery’s useable capacity within one hour or less. Only batteries specifically designed and rated for the requirements imposed by fast-charge applications should be employed in such applications.

**Gas Gauging:** Computation of the amount of energy remaining in a battery. This is typically done by coulometric means, that is, the net current with which the battery is charged is metered and integrated. Any currents drawn out of the battery are then metered and subtracted from the integrated total. More sophisticated versions of this same concept use look-up tables and/or algorithmic means to allow for the effects of such variables as charging rate, discharge rate, and temperature during charge and discharge phases of battery use. These corrections compensate for measurement discrepancies which the battery’s variable charge acceptance and actual capacity might otherwise cause.

**Gas Gauge:** To perform the gas gauging function. Also, a device or display used somewhere within the system employing the gas gauging function, to indicate the status of the battery to the user and/or to system software routines.

**Gas Gauge Mode:** The LTC1325 can be programmed into this functional mode to measure load currents sensed by R<sub>SENSE</sub>. The voltage across R<sub>SENSE</sub> is multiplied by –4, RC filtered before being converted by the ADC. The RC filter consists of an internal 1k resistor and an external non-polarised capacitor C<sub>FILTER</sub> connected at the Filter pin of the LTC1325.

**Gassing:** The generation of gas(es) within a cell as it approaches and enters the overcharge regime. Gassing is an anticipated part of the cell’s operation, and is not harmful unless the rate of gassing exceeds the rate at which the cell can recombine the gas(es) generated. Under such circumstances, the excess gas(es) will escape to the outside of the cell through a pressure relief valve, causing the permanent loss to the cell of some of the electrolyte from which the gas(es) were evolved.

**High-Rate Charge:** The first stage of the two or more stage fast-charge regimen, during which current is flowing

through the battery under charge at a greater rate than the battery can allow on a continuous basis. This portion of the fast-charge requires specific external termination.

**HTF:** High Temperature Fault. Refers either to the HTF status bit or to the highest battery temperature at which charging or discharging is permitted by the LTC1325. Charging is automatically terminated by the LTC1325 when the voltage at the  $T_{BAT}$  pin is less than the voltage at the HTF pin.

**I<sub>CHG</sub>:** Average Charging Current. This should be within recommended limits for the battery.

**I<sub>DIS</sub>:** Average Discharge Current. This should be within recommended limits for the battery.

**Idle Mode:** The LTC1325 can be programmed into this mode when none of the other modes are needed or to make ADC measurements without the presence of switching noise.

**Inflection Point Cutoff ( $d^2V_{BAT}/dt^2$ ):** A charge termination technique used with Nickel-Cadmium and Nickel Metal Hydride batteries. During charge at a constant rate (e.g., the high-current portion of a fast-charge regimen), the terminal voltage of such batteries increases until the battery is slightly into overcharge. The rate of this increase, however, is not linear with respect to time. Shortly before the battery reaches full charge, the rate of change of terminal voltage becomes constant; at the time the battery becomes fully charged this rate of change becomes either zero or negative. The second derivative of the battery's voltage with respect to time can therefore be used to indicate that point at which the battery is near full charge, by looking for either a zero, or more commonly a negative, value of  $d^2V_{BAT}/dt$ .

**Incremental Temperature Cutoff ( $\Delta TCO$ ):** A Charge Termination Method (or Secondary Charge Termination Method) frequently used to terminate the high-rate portion of a fast-charge regimen. TCO makes use of the fact that the case of a fully charged cell will experience a relatively rapid temperature rise as it goes into high-rate overcharge (typically  $0.5^\circ\text{C}/\text{minute}$  to  $1^\circ\text{C}/\text{minute}$ ).

**LTF:** Low Temperature Fault. Refers either to the LTF status bit or to the lowest battery temperature at which charging or discharging is permitted by the LTC1325.

Charging is automatically terminated when the voltage at the  $T_{BAT}$  pin of the LTC1325 is greater than the voltage at the LTF pin.

**MCV:** Maximum Cell Voltage. Refers either to the MCV status bit or the highest permissible  $V_{CELL}$ . Charging is automatically terminated by the LTC1325 when the cell voltage ( $V_{CELL}$ ) is greater than the voltage at the MCV pin.

**Negative  $\Delta$  Voltage ( $-\Delta V$ ):** A Charge Termination Method (or Secondary Charge Termination Method) frequently used to terminate the high rate portion of a fast-charge regimen. This method makes use of the fact that the voltage across a Nickel-Cadmium cell, and to a lesser degree, a Nickel-Metal Hydride cell, will experience a maximum voltage and a subsequent voltage decrease (the " $-\Delta V$ ") once it goes into high-rate overcharge (typically between  $-20\text{mV}$  and  $-50\text{mV}$  for a Nickel-Cadmium cell). This technique is most commonly employed with NiCd batteries.

**NiCd:** Nickel-Cadmium

**NiMH:** Nickel-Metal Hydride

**NTC:** Negative Temperature Coefficient. Also used in this Application Note to refer to thermistors with negative temperature coefficients.

**Overcharge:** The situation which arises when a cell has been returned to its state of full charge, but the charging current to the cell is not removed. Of necessity, cells are designed to handle a certain amount of overcharge, hence, this is not necessarily either a harmful or an undesirable condition. During overcharge, the excess electrical energy applied to the cell which does not go towards preventing self-discharge is dissipated as heat, through the formation and recombination of gas(es) within the cell.

**PTC:** Positive Temperature Coefficient. Also used in this Application Note to refer to thermistors with positive temperature coefficients.

**Quick-Charge:** A charging regimen for Nickel-Cadmium and Nickel-Metal Hydride batteries which can return 100% of usable capacity to the battery in five hours. Batteries to be charged in this manner must be rated for such charging. The charging current for this regimen is usually stipulated by the manufacturer to be  $0.33C$ .

## Application Note 64

---

**R<sub>DIS</sub>**: External resistor in LTC1325-based circuits to limit battery discharge currents to within recommended limits for the battery.

**R<sub>DS(ON)</sub>**: Drain to source on-resistance of a MOSFET.

**Required Charging Voltage**: The minimum voltage which should be available with which to charge a given type of battery, in a given charge regimen. Essentially, the compliance voltage capability of the charger, as dictated by the voltage which the battery can be expected to achieve during the charging cycle.

**R<sub>SENSE</sub>**: Sense Resistor. An external resistor in LTC1325-based circuits which is connected between the Sense pin and ground. This resistor is used to sense battery current in charge and gas gauge modes.

**R<sub>TRK</sub>**: Trickle Resistor. An external resistor in LTC1325-based circuits. This resistor has three purposes: 1) it keeps the battery in a fully charged condition after charging is completed, 2) it trickle-charges a deeply discharged battery to raise its cell voltage above 100mV so that charging may commence, and 3) it pulls the V<sub>BAT</sub> pin high whenever the battery is removed. This tells the LTC1325 that the battery has been removed.

**Secondary Charge Termination Methods**: Certain charging algorithms, especially fast-charge algorithms, have the potential to damage the batteries which they are charging if charge termination does not occur properly. For this reason, such algorithms generally employ more than one termination method. Secondary Charge Termination Methods are those which provide redundancy for the chosen Charge Termination Method.

**Self-Discharge**: The characteristic of electrochemical storage cells to bring themselves to the discharged state, even when their terminals are open-circuited.

**Self-Discharge Rate**: The rate at which an electrochemical storage cell brings itself towards the discharged state, with its terminals open-circuited. This rate is, for example, approximately 0.5%/day to 1%/day for Nickel-Cadmium and Nickel-Metal Hydride cells at room temperature.

**Shutdown Mode**: The LTC1325 is programmed into this functional mode to reduce current drain on V<sub>DD</sub> supply to 30mA typical.

**Standard Capacity**: The capacity for electrical energy storage of a cell which is in good condition. The necessary tests to ascertain this capacity is carried out under the cell manufacturer's specified standard conditions, which are generally those at which the cell can be expected to deliver its best performance.

**Standard-Charge**: An "overnight" charge method. This regimen typically involves charging at the 0.1C rate, requiring 14 to 16 hours to perform a complete charge on a battery.

**T<sub>AMB</sub>**: Refers to ambient temperature or to the T<sub>AMB</sub> pin of the LTC1325. This pin is connected to an undedicated channel of the 10-bit ADC and may be used to monitor ambient temperature.

**T<sub>BAT</sub>**: Refers to either battery temperature or the voltage at the T<sub>BAT</sub> pin of the LTC1325.

**Temperature Cutoff (TCO)**: A technique for determining at what point to terminate the charging of a cell or battery. The absolute temperature of the cell (or one cell of a battery) is monitored by a temperature-sensitive element which, upon detecting a preset temperature, will either reduce or terminate the charging current to the cell or battery. TCO is frequently used as a backup termination method in fast-charge systems.

**Time-Out**: A time limit on charge and discharge time. May be one of eight values: 5, 10, 20, 40, 80, 160, 320 minutes or no time-out.

**Top-Off Charge**: The second portion of the three-stage fast-charge regimen, during which the rate of current flow through the battery under charge is cut back significantly from the high-rate value. This portion of the charge serves to put the battery barely into overcharge.

**Trickle-Charge**: The third stage of the three-stage fast-charge regimen, during which the rate of current flow through the battery under charge is kept at a sufficient level to prevent the battery from self-discharging, but which contributes little to the charging of the battery per se. The current level required for trickle-charge may or may not be lower than that used for the toff-charge.

**V<sub>CELL</sub>**: Cell Voltage. The battery voltage divided by the programmed setting of the LTC1325 battery divider.

---

**V<sub>DAC</sub>**: A programmable reference voltage in the LTC1325 which determines the average voltage at the Sense pin when the LTC1325 is programmed into charge mode. V<sub>DAC</sub> may be set to one of four values.

**V<sub>DC</sub>**: Positive charging supply in the LTC1325 circuits described in this Application Note.

**V<sub>DD</sub>**: Positive supply pin of the LTC1325. Same as V<sub>DC</sub> for voltages between 4.5V to 16V.

**V<sub>EC</sub>**: End of Charge Voltage. The maximum voltage across each cell of the battery when fully charged. The voltage at the MCV pin should be set above V<sub>EC</sub> to prevent false fail-safes from occurring.

**Venting**: The loss of gas(es) from the inside of a nominally “sealed” cell to the ambient, through the cell’s pressure relief valve. Venting is indicative of a harmful level of overcharge, and will cause eventual irreparable damage to the cell.

**V<sub>BAT</sub>**: Battery Voltage

**V<sub>IN</sub>**: Refers to the V<sub>IN</sub> pin of the LTC1325 or its voltage. This pin is connected to an undedicated channel of the 10-bit ADC and may be used to monitor any desired voltage within the 3V range of the ADC.

**Zero Voltage (Zero V)**: A Charge Termination Method (or Secondary Charge Termination Method) frequently used to terminate the high-rate portion of a fast-charge regimen. This method makes use of the fact that the voltage across a Nickel-Metal Hydride or Nickel-Cadmium cell will experience a voltage maximum, and subsequent voltage decrease or plateau once it goes into high-rate overcharge. The point at which voltage stops increasing during charging is the point of Zero V. This technique is most commonly employed with NiMH batteries.

---

## APPENDIX D

### External Component Sources List

#### Batteries

Duracell USA (HQ)  
Berkshire Corporate Park  
Bethel, CT 06801  
(203) 796-4000  
(800) 243-9540  
FAX: (203) 730-8958

Energizer Power Systems  
Div. of Eveready Battery Co., Inc.  
Highway 441 North  
P.O. Box 147114  
Gainesville, FL 32614-7114  
(904) 462-3911  
FAX: (904) 462-6210

GP Batteries (U.S.A.) Inc,  
2772 Loker Avenue West  
Carlsbad, CA 92008  
(619) 438-2202  
FAX: (619) 438-0694

GS Battery (USA) Inc.  
17253 Chestnut Street  
City of Industry, CA 91748  
(818) 964-8348  
FAX: (818) 810-9438

Hawker Energy Products, Inc.  
617 N. Ridgeview Drive  
Warrensburg, MO 64093-9301  
(816) 429-2165  
FAX: (816) 429-2253

Panasonic Industrial Company  
Headquarters:  
P. O. Box 1511  
Secaucus, NJ 07096  
(201) 348-5272  
FAX: (201) 392-4728

SAFT America, Inc.  
Otay Commerce Center  
2155 Paseo de las Americas, #31  
San Diego, CA 92173  
(619) 661-7992  
FAX: (619) 661-5096

SANYO Energy (U.S.A.) Corporation  
2001 Sanyo Avenue  
San Diego, CA 92173  
(619) 661-6620  
FAX: (619) 661-6743

Tadiran Electronic Industries, Inc.  
2 Seaview Boulevard  
Port Washington, NY 11050  
(800) 786-9887  
(516) 621-4980  
FAX: (516) 621-4517

---

## Application Note 64

---

Varta Batteries Inc. (USA)  
300 Executive Boulevard  
Elmsford, NY 10523-1202  
(914) 592-2500  
FAX: (914) 592-2667

### **Inductors**

Coiltronics, Inc.  
6000 Park of Commerce Boulevard  
Boca Raton, FL 33487  
(407) 241-7876  
FAX: (407) 241-9339

Dale Electronics, Inc.  
East Highway 50  
P.O. Box 180  
Yankton, SD 57078-0180  
(605) 665-9301  
FAX: (605) 665-1627

Hurricane Electronics Lab  
P.O. Box 1280  
331 North 2260 West  
Hurricane, UT 84737  
(801) 635-2003  
FAX: (801) 635-2495

Sumida Electric (USA) Corp., Ltd.  
5999 New Wilkie Road  
Suite 110  
Rolling Meadows, IL 60008  
(847) 956-0666  
FAX: (847) 956-0702

### **Thermistors**

Alpha Thermistor and Assembly Inc.  
7181 Construction Court  
San Diego, CA 92121  
(619) 549-4660  
FAX: (619) 549-4791

Fenwal Electronics Inc.  
450 Fortune Boulevard  
Milford, MA 01757  
(508) 478-6000  
FAX: (508) 473-6035

Panasonic Industrial Company  
Two Panasonic Way, 7H-3  
Secaucus, NJ 07094  
(201) 348-5232  
FAX: (201) 392-4441

Phillips Components  
Discrete Products Division  
2001 W. Blue Heron Blvd.  
P.O. Box 10330  
Riviera Beach, FL 33404  
(407) 881-3200

Thermometrics Inc.  
808 U.S. Highway 1  
Edison, NJ 08817  
(908) 287-2870  
FAX: (908) 287-8847

### **MOSFETs**

International Rectifier  
U.S. World Headquarters  
233 Kansas Street  
El Segundo, CA 90245  
(310) 322-3331  
FAX: (310) 322-3332

Motorola Semiconductor, Inc.  
3102 North 56th Street  
MS56-126  
Phoenix, AZ 85018  
(800) 521-6274

Siliconix Inc.  
2201 Laurelwood Road  
P.O. Box 54951  
Santa Clara, CA 95056  
(408) 988-8000  
FAX: (408) 970-3950

### **Schottky Diodes**

General Instrument  
Power Semiconductor Division  
10 Melville Park Road  
Melville, NY 11747  
(516) 847-3000

International Rectifier  
U.S. World Headquarters  
233 Kansas Street  
El Segundo, CA 90245  
(310) 322-3331  
FAX: (310) 322-3332

Motorola Semiconductor, Inc.  
3102 North 56th Street  
MS56-126  
Phoenix, AZ 85018  
(800) 521-6274

### **Polymer PTCs**

Raychem Corporation  
PolySwitch Division  
300 Constitution Drive  
Menlo Park, CA 94025-1164  
(800) 272-9243, x6900  
FAX: (800) 227-4866

### **Bimetallic Thermostats**

Phillips Technologies  
Airtax Protector Group  
550 Highland Avenue  
Frederick, MD 21701  
(301) 663-5141  
FAX: (301) 698-0624

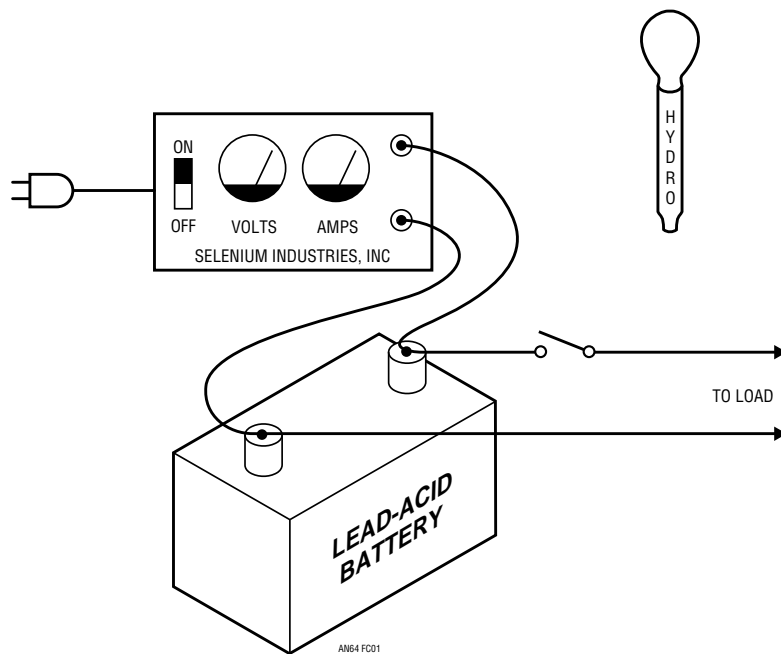

**Early Battery Management**

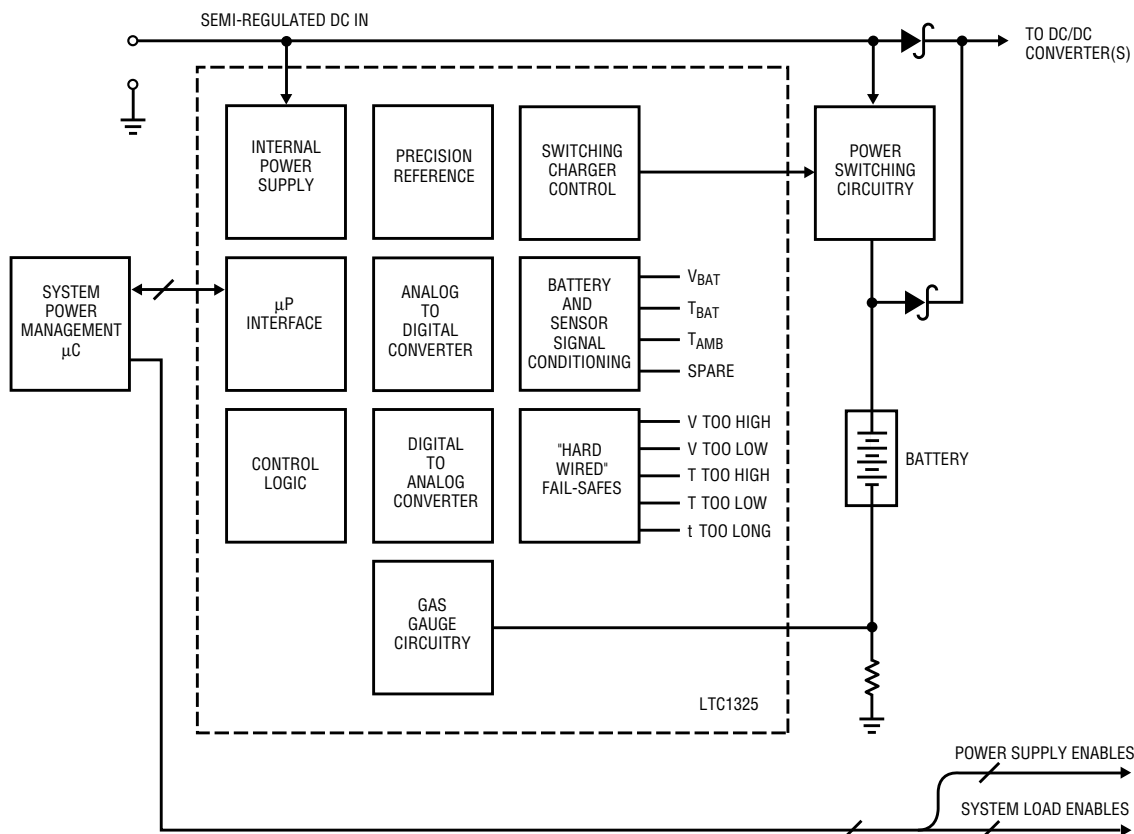

**Modern Battery Management**

# Application Note 64

---

## U.S. Area Sales Offices

### NORTHEAST REGION

**Linear Technology Corporation**  
3220 Tillman Drive, Suite 120  
Bensalem, PA 19020  
Phone: (215) 638-9667  
FAX: (215) 638-9764

**Linear Technology Corporation**  
266 Lowell Street, Suite B-8  
Wilmington, MA 01887  
Phone: (508) 658-3881  
FAX: (508) 658-2701

### NORTHWEST REGION

**Linear Technology Corporation**  
1900 McCarthy Blvd., Suite 205  
Milpitas, CA 95035  
Phone: (408) 428-2050  
FAX: (408) 432-6331

### SOUTHEAST REGION

**Linear Technology Corporation**  
17000 Dallas Parkway, Suite 219  
Dallas, TX 75248  
Phone: (214) 733-3071  
FAX: (214) 380-5138

**Linear Technology Corporation**  
5510 Six Forks Road, Suite 102  
Raleigh, NC 27609  
Phone: (919) 870-5106  
FAX: (919) 870-8831

### CENTRAL REGION

**Linear Technology Corporation**  
Chesapeake Square  
229 Mitchell Court, Suite A-25  
Addison, IL 60101  
Phone: (708) 620-6910  
FAX: (708) 620-6977

### SOUTHWEST REGION

**Linear Technology Corporation**  
21243 Ventura Blvd., Suite 227  
Woodland Hills, CA 91364  
Phone: (818) 703-0835  
FAX: (818) 703-0517

**Linear Technology Corporation**  
15375 Barranca Parkway, Suite A-211  
Irvine, CA 92718  
Phone: (714) 453-4650  
FAX: (714) 453-4765

## International Sales Offices

### FRANCE

**Linear Technology S.A.R.L.**  
Immeuble "Le Quartz"  
58 Chemin de la Justice  
92290 Chatenay Malabry  
France  
Phone: 33-1-41079555  
FAX: 33-1-46314613

### GERMANY

**Linear Technology GmbH**  
Oskar-Messter-Str. 24  
85737 Ismaning  
Germany  
Phone: 49-89-962455-0  
FAX: 49-89-963147

### JAPAN

**Linear Technology KK**  
5F NAO Bldg.  
1-14 Shin-Ogawa-cho Shinjuku-ku  
Tokyo, 162 Japan  
Phone: 81-3-3267-7891  
FAX: 81-3-3267-8510

### KOREA

**Linear Technology Korea Co., Ltd**  
Namsong Building, #403  
Itaewon-Dong 260-199  
Yongsan-Ku, Seoul 140-200  
Korea  
Phone: 82-2-792-1617  
FAX: 82-2-792-1619

### SINGAPORE

**Linear Technology Pte. Ltd.**  
507 Yishun Industrial Park A  
Singapore 2776  
Phone: 65-753-2692  
FAX: 65-754-4113

### SWEDEN

**Linear Technology AB**  
Sollentunavägen 63  
S-191 40 Sollentuna  
Sweden  
Phone: 46-8-623-1600  
FAX: 46-8-623-1650

### TAIWAN

**Linear Technology Corporation**  
Rm. 602, No. 46, Sec. 2  
Chung Shan N. Rd.  
Taipei, Taiwan, R.O.C.  
Phone: 886-2-521-7575  
FAX: 886-2-562-2285

### UNITED KINGDOM

**Linear Technology (UK) Ltd.**  
The Coliseum, Riverside Way  
Camberley, Surrey GU15 3YL  
United Kingdom  
Phone: 44-1276-677676  
FAX: 44-1276-64851

## World Headquarters

**Linear Technology Corporation**  
1630 McCarthy Blvd.  
Milpitas, CA 95035-7417  
Phone: (408) 432-1900  
FAX: (408) 434-0507