



Data Acquisition Circuit Collection

Kevin R. Hoskins

INTRODUCTION

This application note features 8-, 10-, and 12-bit data acquisition components in various circuit configurations. The circuits include battery monitoring, temperature sensing, isolated serial interfaces, and microprocessor and microcontroller serial and parallel interfaces. Also included are voltage reference circuits (Application Note 42 contains more voltage reference circuits).

Additional circuit information is located in the information references listed in the Circuit Index. Each information reference refers to either an application note (example: AN42 = Application Note 42), a data sheet (example: LTC[®]1292 DS = LTC1292 Data Sheet), or a design note (example: DN66 = Design Note 66).

and LTC are registered trademarks and LT is a trademark of Linear Technology Corporation.

CIRCUIT INDEX

FIGURE TITLE	FIGURE NO.	PAGE	INFORMATION REFERENCE/SOURCE
General Analog-to-Digital Application Circuits			
Two-Quadrant 150kHz Bandwidth Analog Multiplier	Figure 1	AN62-3	LTC1099 DS
Infinite Hold-Time Sample-and-Hold ($t_{ACQ} = 240ns$)	Figure 2	AN62-3	LTC1099 DS
Four-Quadrant 250kHz Bandwidth Analog Multiplier	Figure 3	AN62-4	
Demodulating a Signal Using Undersampling	Figure 4	AN62-4	LTC1257 DS
Complete 100ps Resolution Δ Time Circuit with "Bow" Correction	Figure 5	AN62-5	LTC1282 DS
Single 5V 12-Bit Temperature Control System with Shutdown	Figure 6	AN62-6	LTC1257 DS
Weight Scale	Figure 7	AN62-6	LTC1091/2/3/4 DS
Auto-Ranging 8-Channel 12-Bit Data Acquisition System with Shutdown	Figure 8	AN62-7	LTC1257 DS
Analog-to-Digital Battery Monitoring Application Circuits			
Micropower Battery Voltage Monitor	Figure 9	AN62-8	LTC1096/8 DS
0A to 2A Battery Current Monitor Draws Only 70 μ A	Figure 10	AN62-8	LTC1096/8 DS
LTC1297 Data Acquisition System Micropower Battery Current Monitor	Figure 11	AN62-9	
Temperature Sensing and Conversion			
Current Output Silicon Sensor Thermometer Driving 10-Bit Analog-to-Digital Converter Covers $-55^{\circ}C$ to $125^{\circ}C$ with $0.2^{\circ}C$ Resolution	Figure 12	AN62-9	LTC1091/2/3/4 DS
Thermistor-Based Temperature Measurement System Covers $20^{\circ}C$ to $40^{\circ}C$ and $0^{\circ}C$ to $100^{\circ}C$ with $0.25^{\circ}C$ Accuracy	Figure 13	AN62-10	LTC1091/2/3/4 DS
Digitally Linearized Platinum RTD Signal Conditioner	Figure 14	AN62-10	LTC1091/2/3/4 DS
Furnace Exhaust Gas Temperature Monitor Covers $0^{\circ}C$ to $500^{\circ}C$ and Has Low Supply Detection	Figure 15	AN62-11	LTC1091/2/3/4/DS
Isolated Interfaces			
Floating Analog-to-Digital Conversion System Powered by Capacitor Charge Pump	Figure 16	AN62-11	LTC1096/8 DS
Micropower Serial 10-Bit Data Acquisition System with 500V Opto-Isolated Communication	Figure 17	AN62-12	LTC1091/2/3/4 DS
Opto-Isolated Temperature Monitor	Figure 18	AN62-13	LTC1292 DS
Battery-Powered Digital Thermometer Transmits Over RF-Link	Figure 19	AN62-13	
LTC1092 10-Bit Analog-to-Digital Converter Receives Power and Transmits Data Over Two Transformer-Isolated Lines	Figure 20	AN62-14	DN19



Application Note 62

FIGURE TITLE	FIGURE NO.	PAGE	INFORMATION REFERENCE/SOURCE
Miscellaneous Circuits			
Two LTC1390s Cascadable Serially Programmed 8-Channel Multiplexers Provide the Single Channel LTC1096 with 16 Analog Inputs	Figure 21	AN62-15	
Small 12-Bit Differential-Input LTC1292 Data Acquisition System Occupies Only 0.35IN ² Including Reference and Power Supply Bypass Components	Figure 22	AN62-15	LTC1292 DS
12-Bit LTC1296 Data Acquisition System Strain Gauge with Bridge-Driver- Power Shutdown	Figure 23	AN62-16	LTC1293/4/6 DS
LTC1282 3V Analog-to-Digital Converter with Full-Scale Adjust	Figure 24	AN62-16	LTC1282 DS
Ultra-Low Full-Scale-Drift LTC1282 3V Analog-to-Digital Converter	Figure 25	AN62-16	LTC1282 DS
Ultra-Low Full-Scale-Drift LTC1273 3V Analog-to-Digital Converter	Figure 26	AN62-16	
“Tiny” LTC1286 12-Bit Differential-Input Data Acquisition System (In SO Package) and “Tiny” LT1019-2.5 Reference Occupies Only 0.47IN ² Including Reference and Power Supply Bypass Components	Figure 27	AN62-17	
Hardware Microcontroller Interfaces			
LTC1296 to Microcontroller Hardware Serial Interface	Figure 28	AN62-17	LTC1293/4/6 DS
LTC1090 to Intel 8051 Microcontroller Hardware Serial Interface	Figure 29	AN62-17	LTC1090 DS
LTC1090 to Motorola MC68HC05C4 Microcontroller Hardware Serial Interface	Figure 30	AN62-17	LTC1090 DS
LTC1090 to Hitachi HD63705 Microcontroller Hardware Serial Interface	Figure 31	AN62-17	LTC1090 DS
LTC1091 to Intel 8051 Microcontroller Hardware Serial Interface	Figure 32	AN62-18	LTC1091/2/3/4 DS
LTC1091 to Motorola MC68HC05C4 Microcontroller Hardware Serial Interface	Figure 33	AN62-18	LTC1091/2/3/4 DS
LTC1095 to Intel 8051 Microcontroller Hardware Serial Interface	Figure 34	AN62-18	LTC1095 DS
LTC1095 to Motorola MC68HC05C4 Microcontroller Hardware Serial Interface	Figure 35	AN62-18	LTC1095 DS
Multiple LTC1095s Sharing One Three-Wire Serial Interface	Figure 36	AN62-18	LTC1095 DS
Multiple LTC1290s Sharing One Three-Wire Serial Interface	Figure 37	AN62-19	LTC1290 DS
Multiple LTC1094s Sharing One Three-Wire Serial Interface	Figure 38	AN62-19	LTC1091/2/3/4 DS
Interfacing the LTC1196 to the Altera EPM5064 PLD	Figure 39	AN62-19	LTC1196/8 DS
SNEAK-A-BIT Circuit for the LTC1090: 11-Bit Resolution from a 10-Bit ADC	Figure 40	AN62-20	LTC1090 DS
PC Serial Interface Circuits			
LTC1094 Analog-to-Digital Converter RS232 Serial Interface Using the LT1180A Dual Driver/Receiver	Figure 41	AN62-20	DN 29
LTC1290 to IBM PC Serial Port	Figure 42	AN62-21	DN 35
Parallel Interface Circuits			
LTC1272/LTC1273/LTC1275/LTC1276 to 8085A/Z80 Microprocessor Hardware Parallel Interface	Figure 43	AN62-21	LTC1272/LTC1273/5/6 DS
LTC1272/LTC1273/LTC1275/LTC1276 to MC68000 Microprocessor Hardware Parallel Interface	Figure 44	AN62-21	LTC1272/LTC1273/5/6 DS
LTC1282 to TMS320C25 DSP Processor Parallel Interface	Figure 45	AN62-22	LTC1282 DS
LTC1272/LTC1273/LTC1275/LTC1276 to TMS32010 DSP Processor Parallel Interface	Figure 46	AN62-22	LTC1272/LTC1273/5/6 DS
LTC1278 to TMS320C25 DSP Processor Parallel Interface	Figure 47	AN62-22	
Reference Circuits			
LT1034-2.5 2.5V Voltage Reference	Figure 48	AN62-22	LT1034 DS
Battery-Powered LT1004-2.5 2.5V Voltage Reference	Figure 49	AN62-22	LT1004 DS
LT1431Z 2.5V Voltage Reference (3-Pin Package)	Figure 50	AN62-23	LT1431 DS
LT1431 2.5V Voltage Reference (8-Pin Package)	Figure 51	AN62-23	LT1431 DS
LT1431Z 5V Voltage Reference (8-Pin Package)	Figure 52	AN62-23	LT1431 DS
LT1027 12-Bit Accurate 5V Voltage Reference Supplying Input Voltages to the LTC1290's V _{REF} and V _{CC} Pins	Figure 53	AN62-23	LT1027 DS
Adjustable References			
LT1021-5 Adjustable 5V Voltage Reference	Figure 54	AN62-23	LT1021 DS
LT1009 2.5V Voltage Reference with ±5% Trim Range	Figure 55	AN62-23	LT1009 DS

FIGURE TITLE

FIGURE NO.

PAGE

**INFORMATION
REFERENCE/SOURCE**

Appendices

Analog-to-Digital/Digital-to-Analog Converter Selection Guides	Appendix A	AN62-24
Voltage Reference Selection Guide	Appendix B	AN62-28

GENERAL ANALOG-TO-DIGITAL APPLICATION CIRCUITS

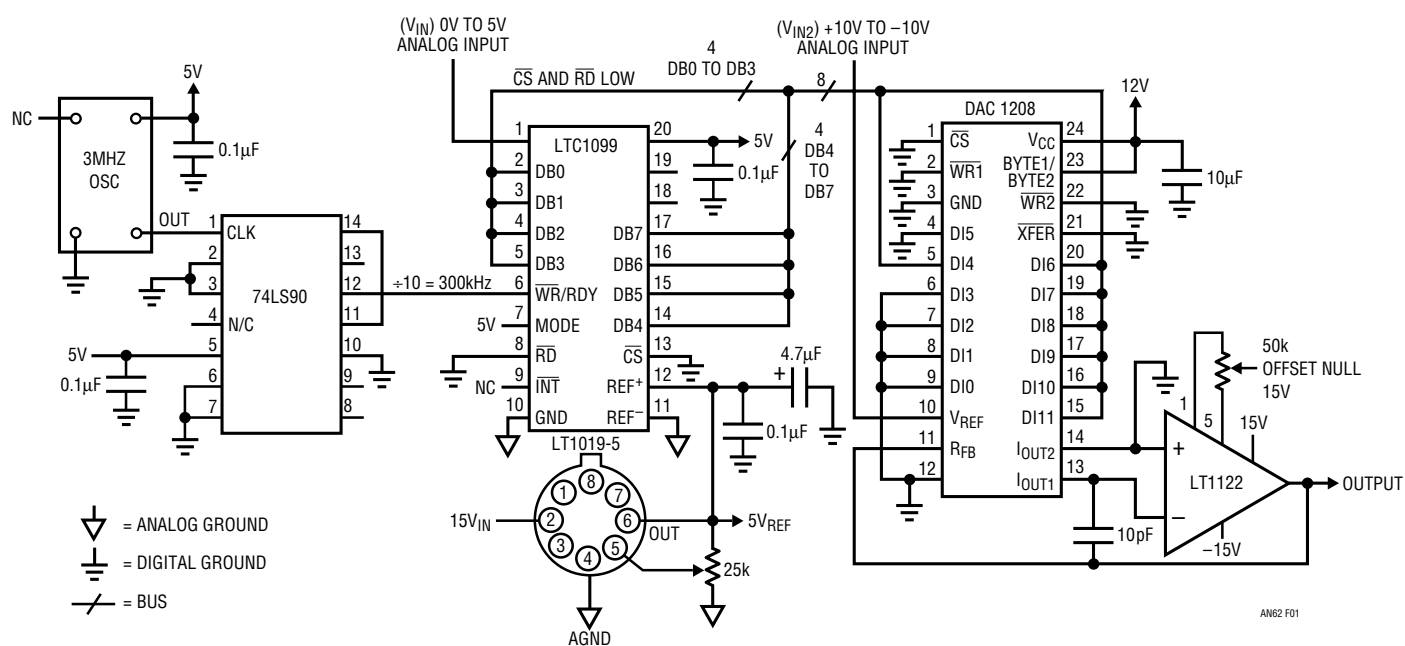

Figure 1. Two-Quadrant 150kHz Bandwidth Analog Multiplier

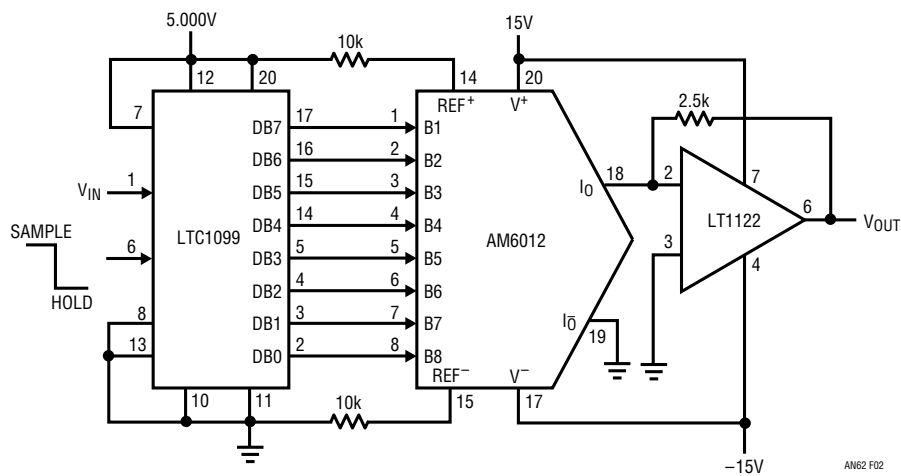

Figure 2. Infinite Hold Time Sample-and-Hold ($t_{ACQ} = 240ns$)

Application Note 62

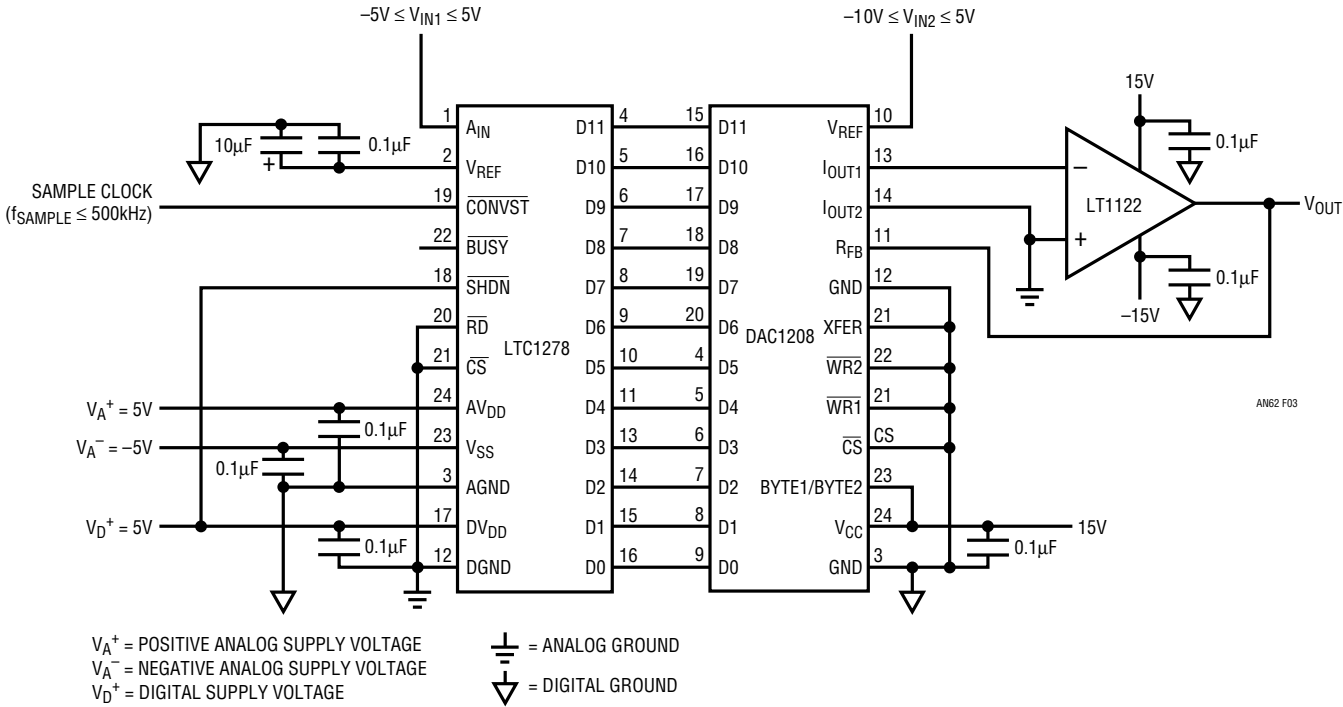

Figure 3. Four-Quadrant 250kHz Bandwidth Analog Multiplier

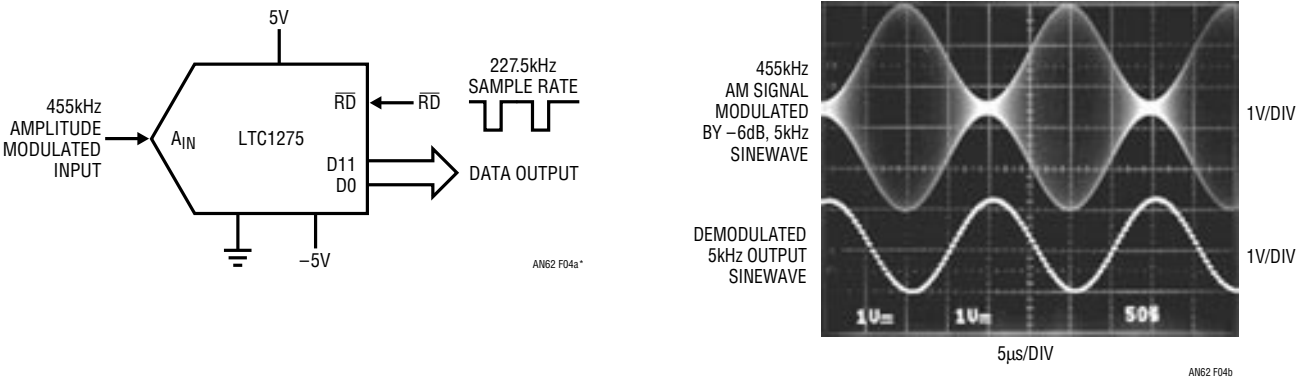
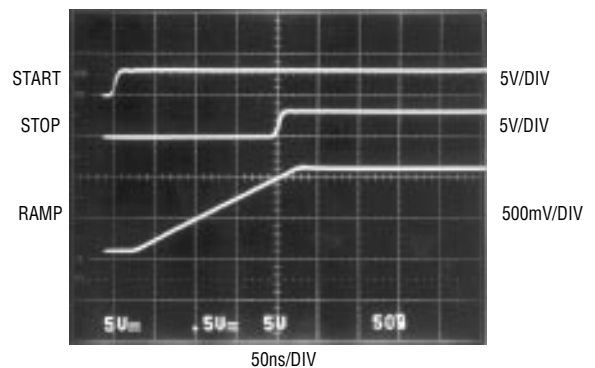
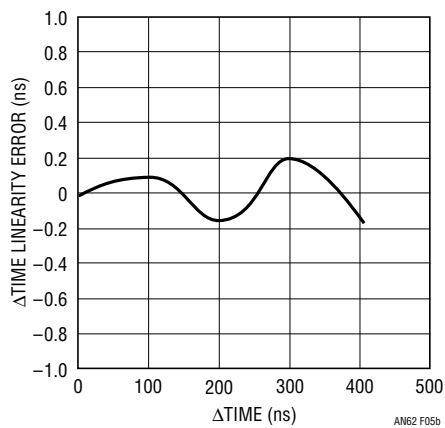
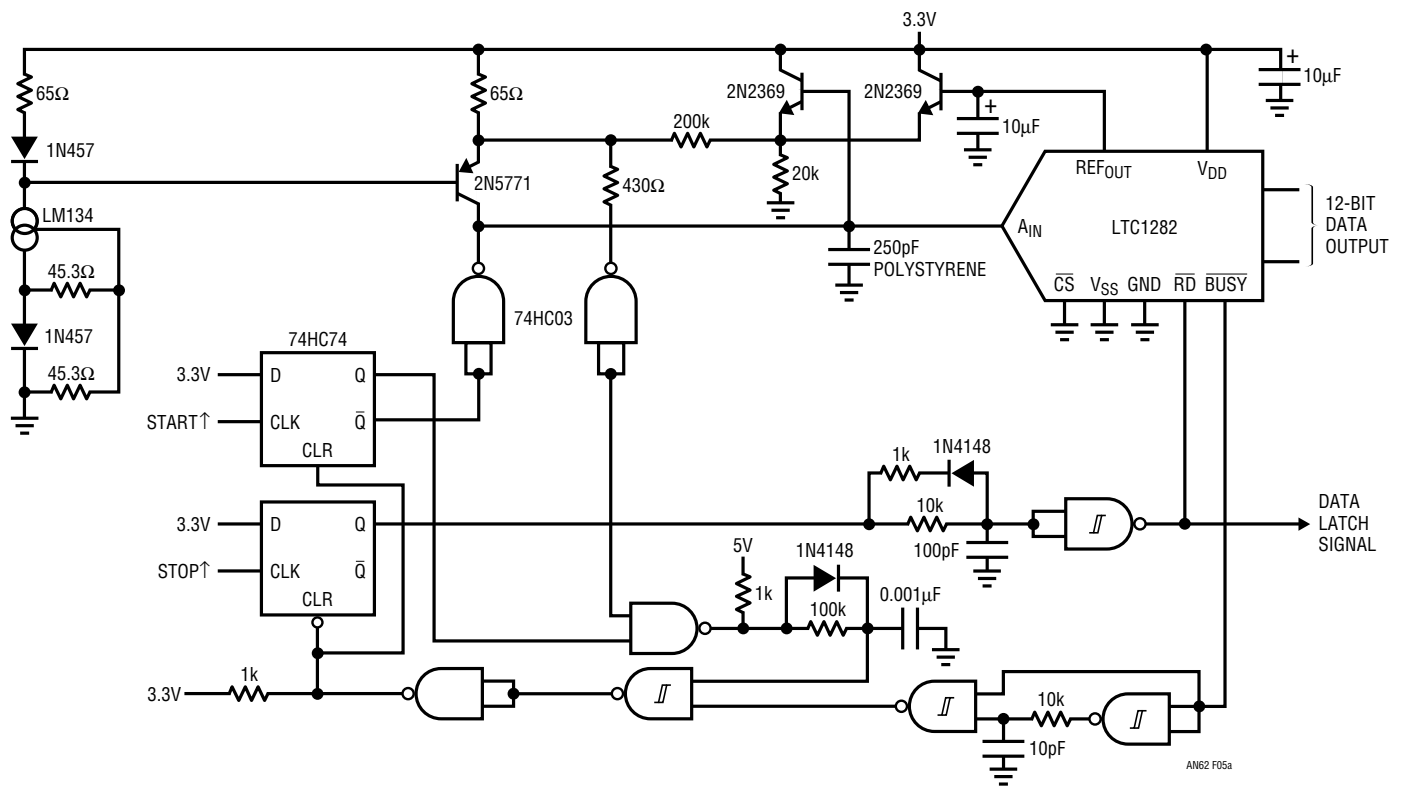

Figure 4. Demodulating a Signal Using Undersampling



THE PHOTO SHOWS THE START, STOP AND RAMP WAVEFORMS FOR A HALFSCALE, 200ns INPUT. THE RAMP REACHES 2.5V IN 400ns FOR A FULL-SCALE ADC INPUT. THE 4096 CODES SPREAD OVER 400ns EQUATE TO 100ps PER LSB.

AN62 F05c

Figure 5. Complete 100ps Resolution Δ Time Circuit with "Bow" Correction

Application Note 62

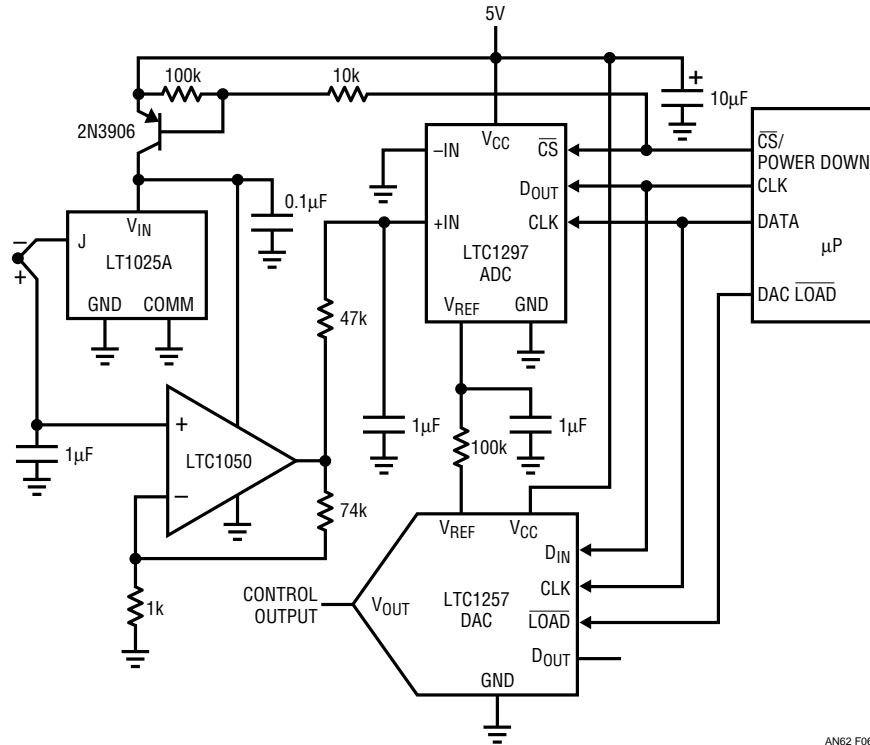

AN62 F06

Figure 6. Single 5V 12-Bit Temperature Control System with Shutdown

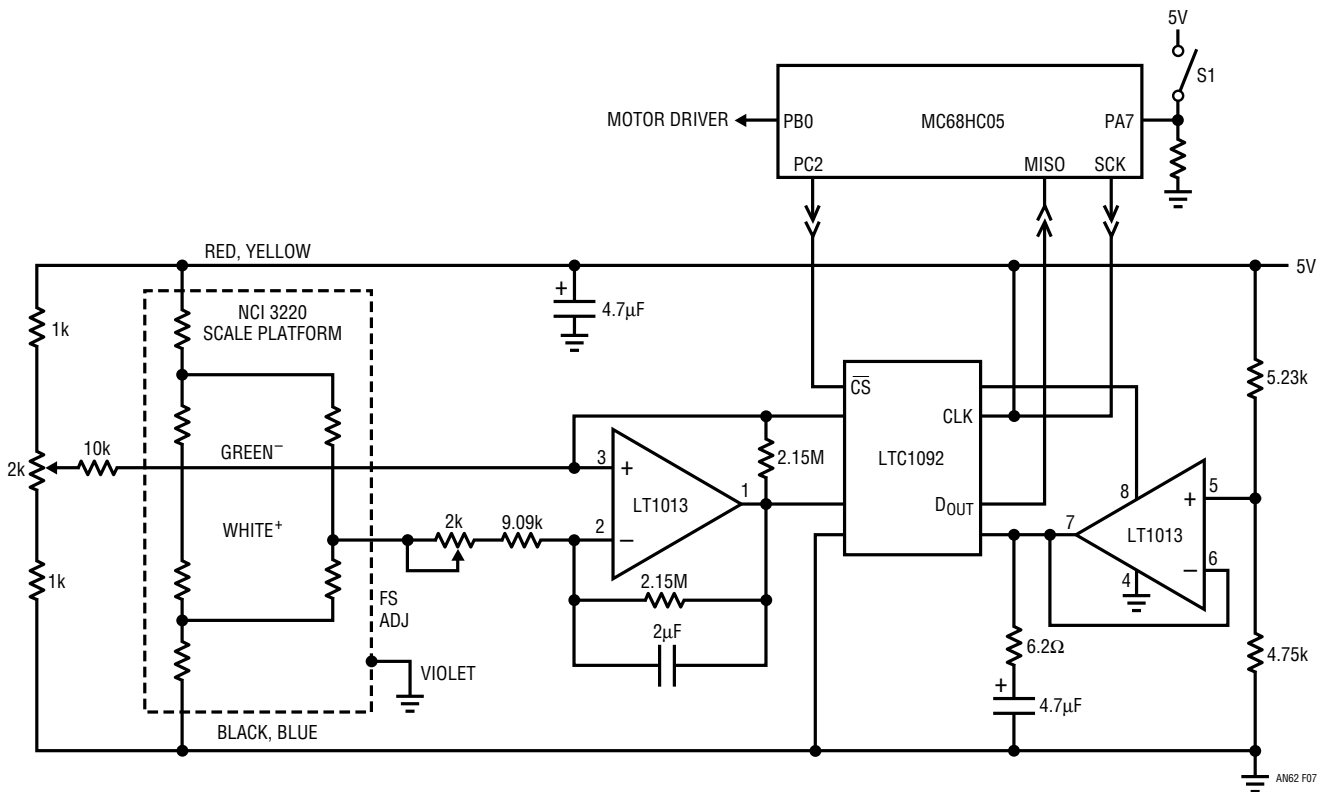

AN62 F07

Figure 7. Weight Scale

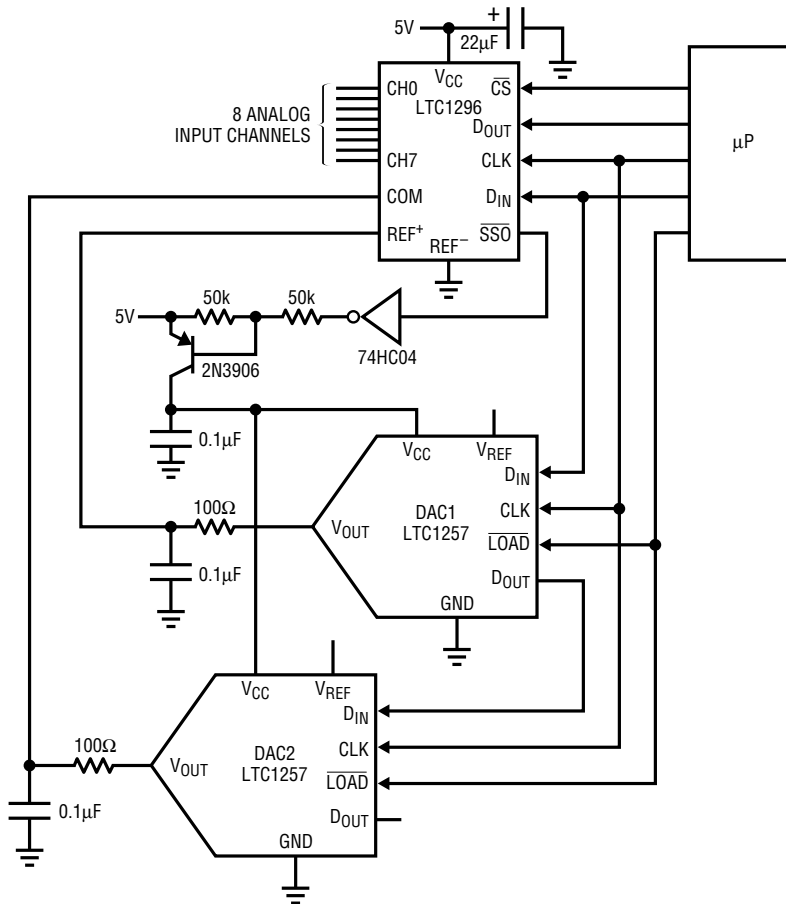

NOTE: THE μP SETS THE LTC1296'S FULL-SCALE AND ZERO-SCALE MAGNITUDES WITH THE CODE APPLIED TO DAC1 AND DAC2, RESPECTIVELY.

AN62 F08

Figure 8. Auto-Ranging 8-Channel 12-Bit Data Acquisition System with Shutdown

Application Note 62

ANALOG-TO-DIGITAL BATTERY MONITORING APPLICATION CIRCUITS

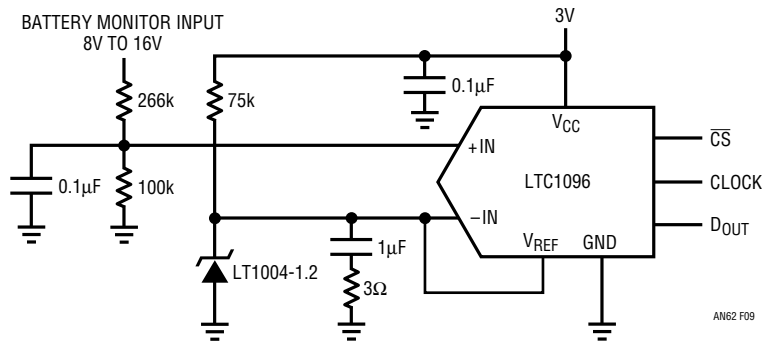

Figure 9. Micropower Battery Voltage Monitor

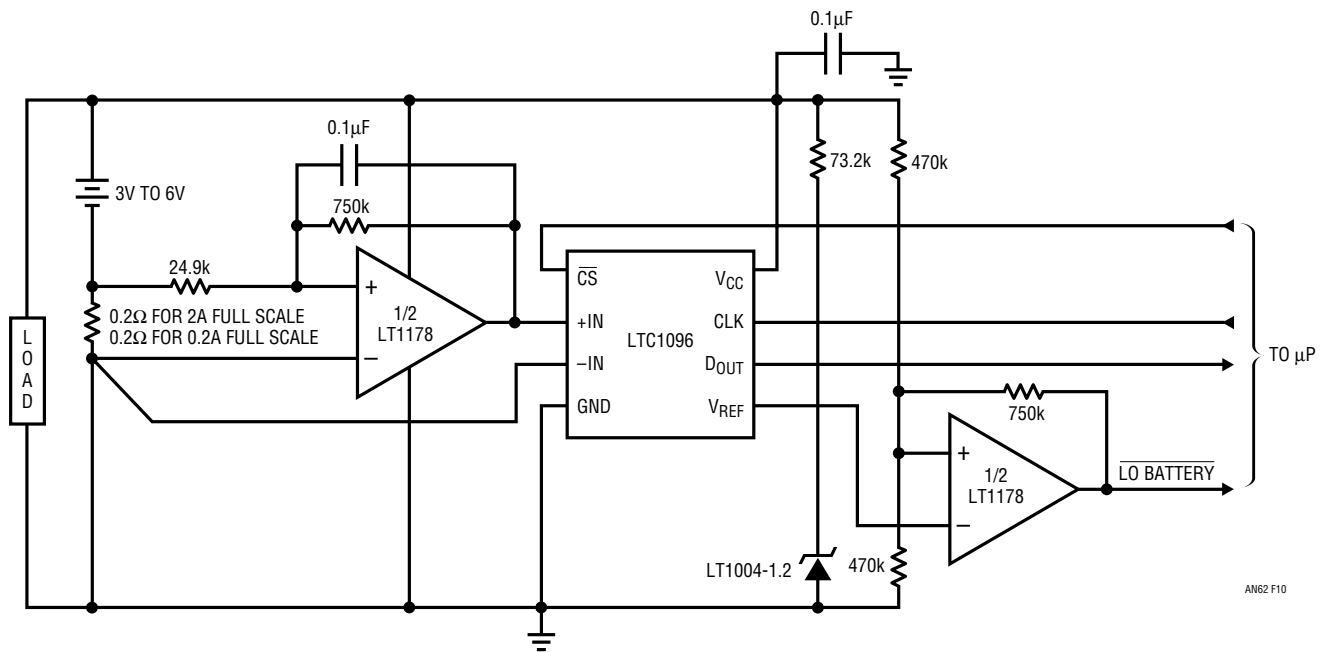

Figure 10. 0A to 2A Battery Current Monitor Draws Only 70μA

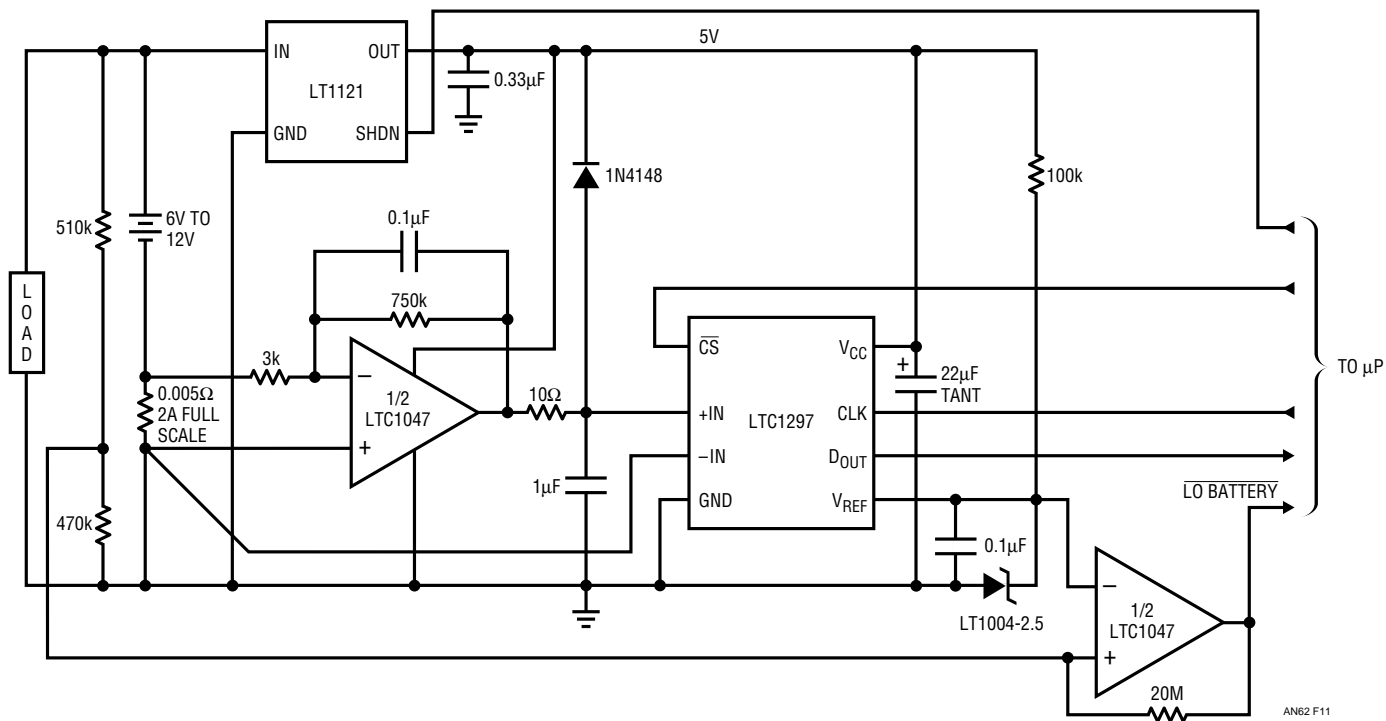

Figure 11. LTC1297 Data Acquisition System Micropower Battery Current Monitor

TEMPERATURE SENSING AND CONVERSION

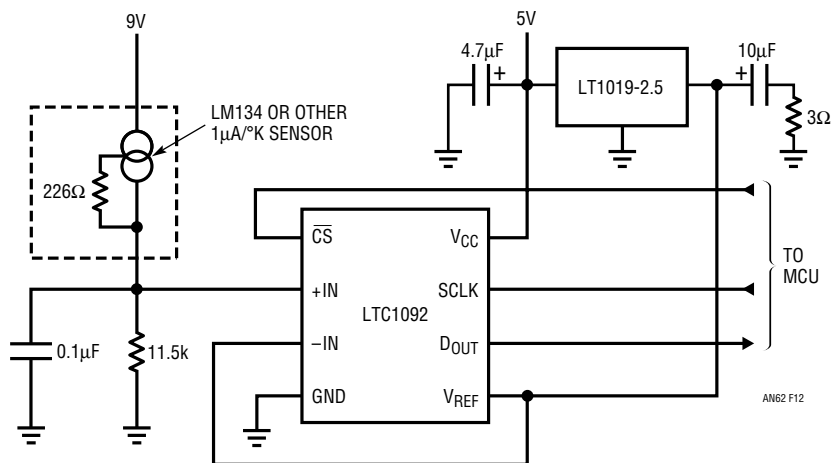

Figure 12. Current Output Silicon Sensor Thermometer Driving 10-Bit Analog-to-Digital Converter Covers -55°C to 125°C with 0.2°C Resolution

Application Note 62

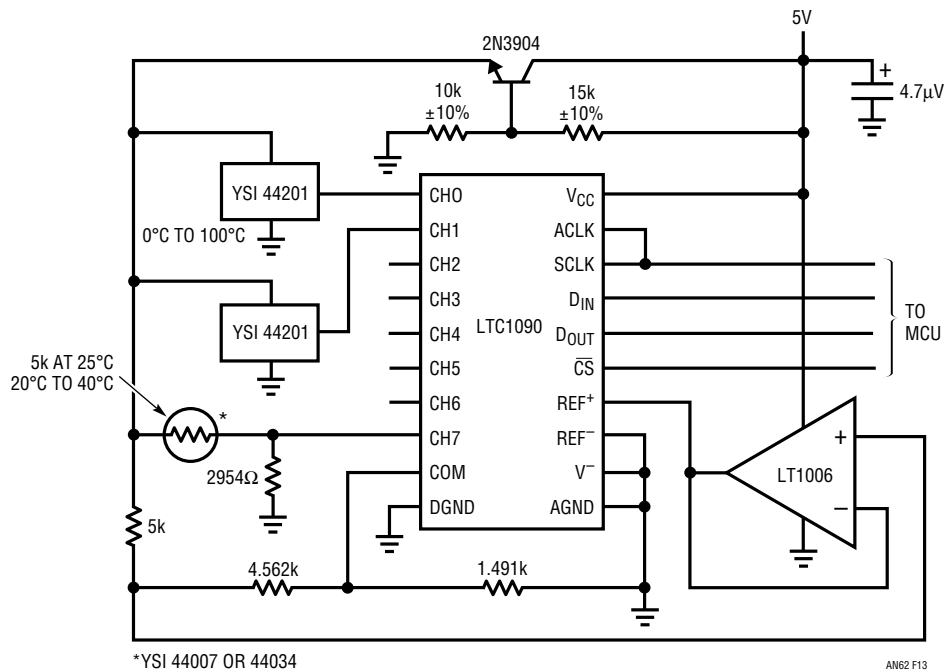

Figure 13. Thermistor-Based Temperature Measurement System Covers 20°C to 40°C and 0°C to 100°C with 0.25°C Accuracy

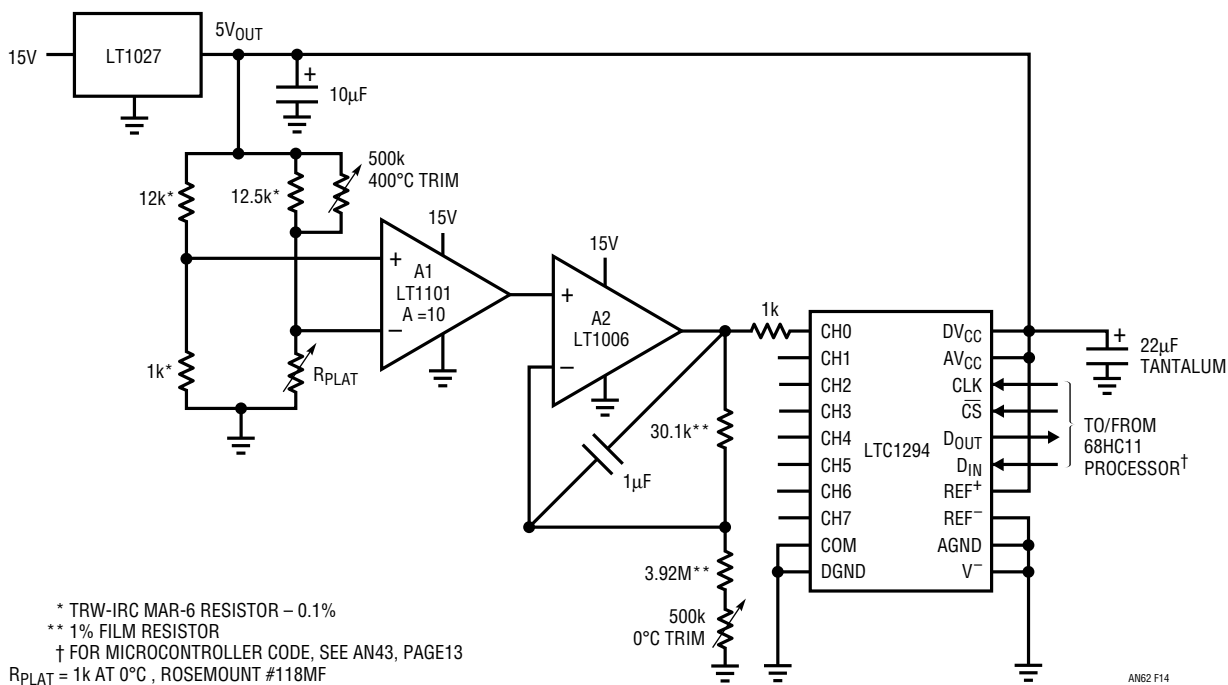

Figure 14. Digitally Linearized Platinum RTD Signal Conditioner

Application Note 62

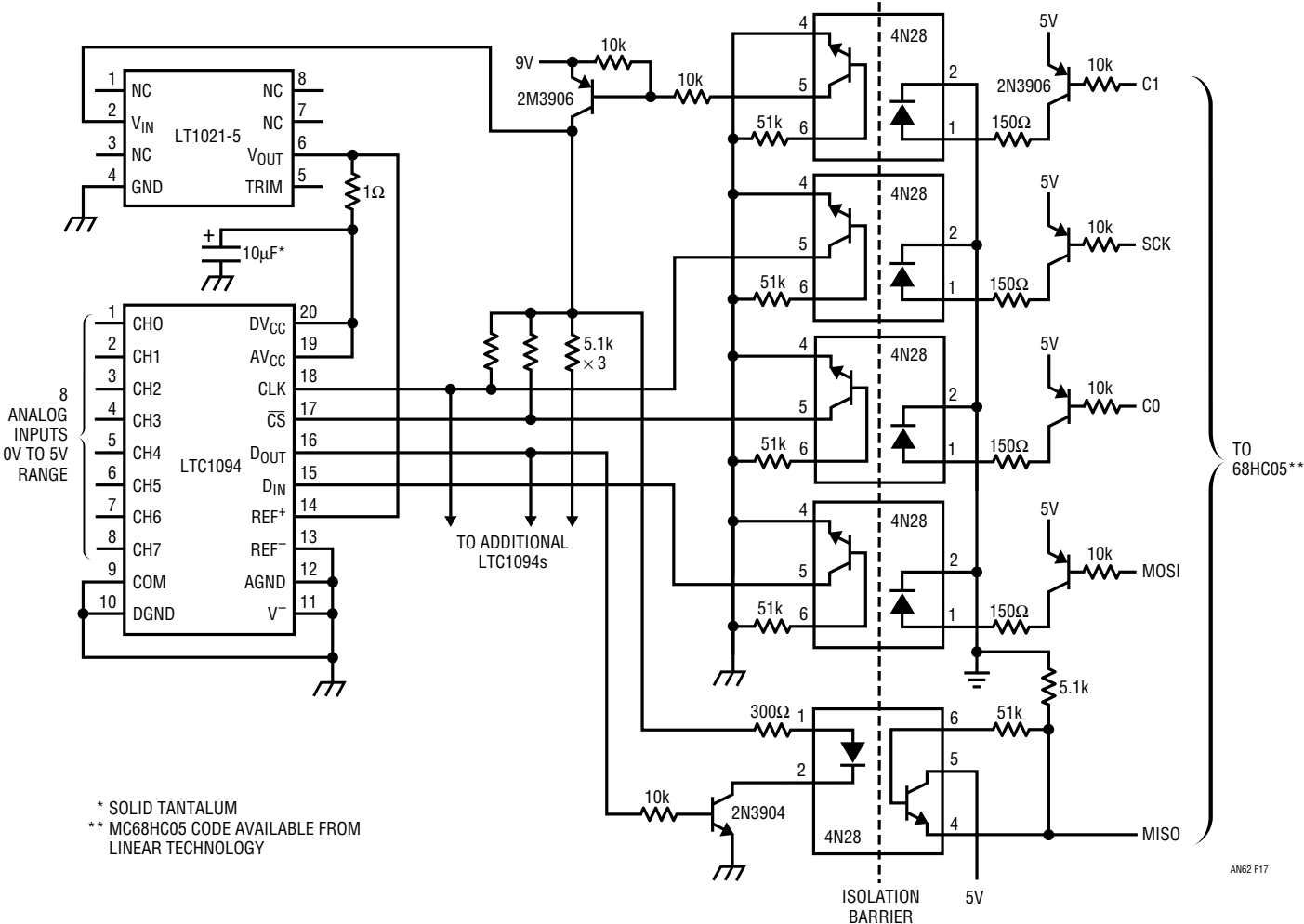

Figure 17. Micropower Serial 10-Bit Data Acquisition System with 500V Opto-Isolated Communication

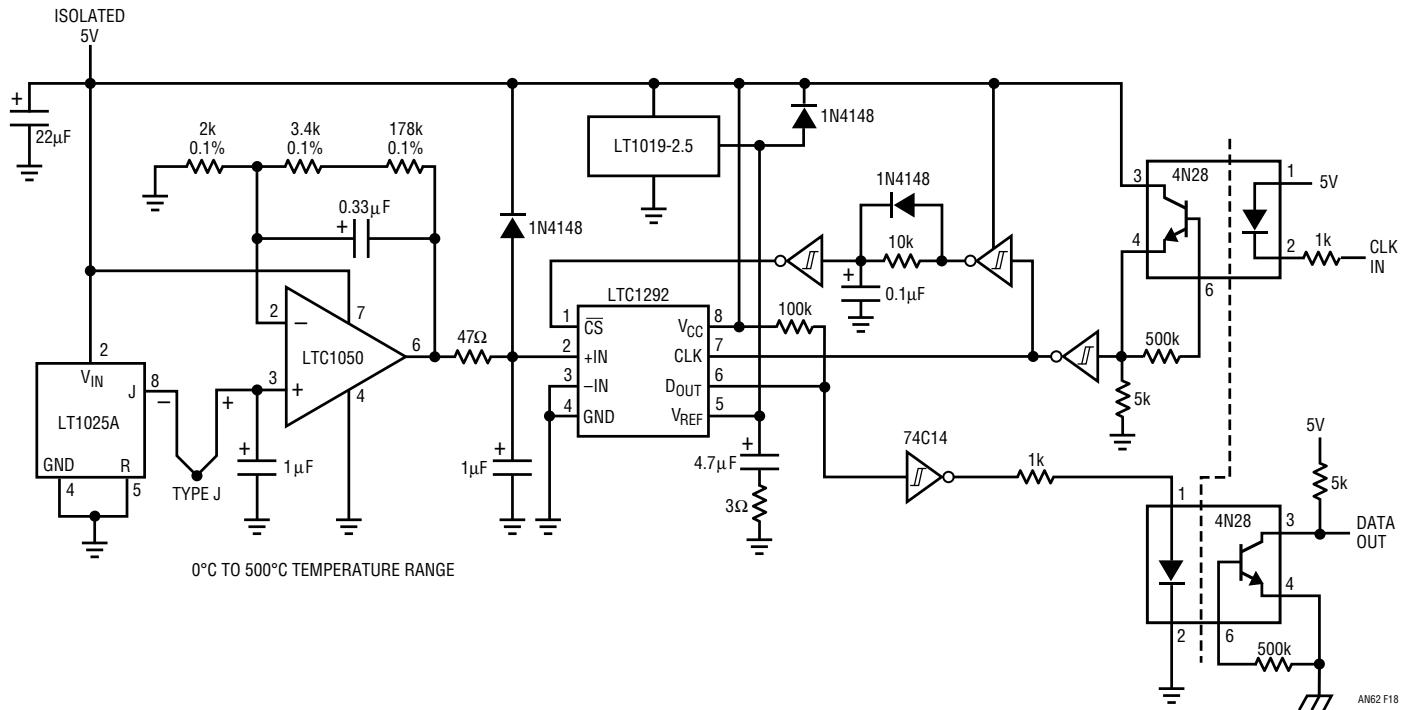

Figure 18. Opto-Isolated Temperature Monitor

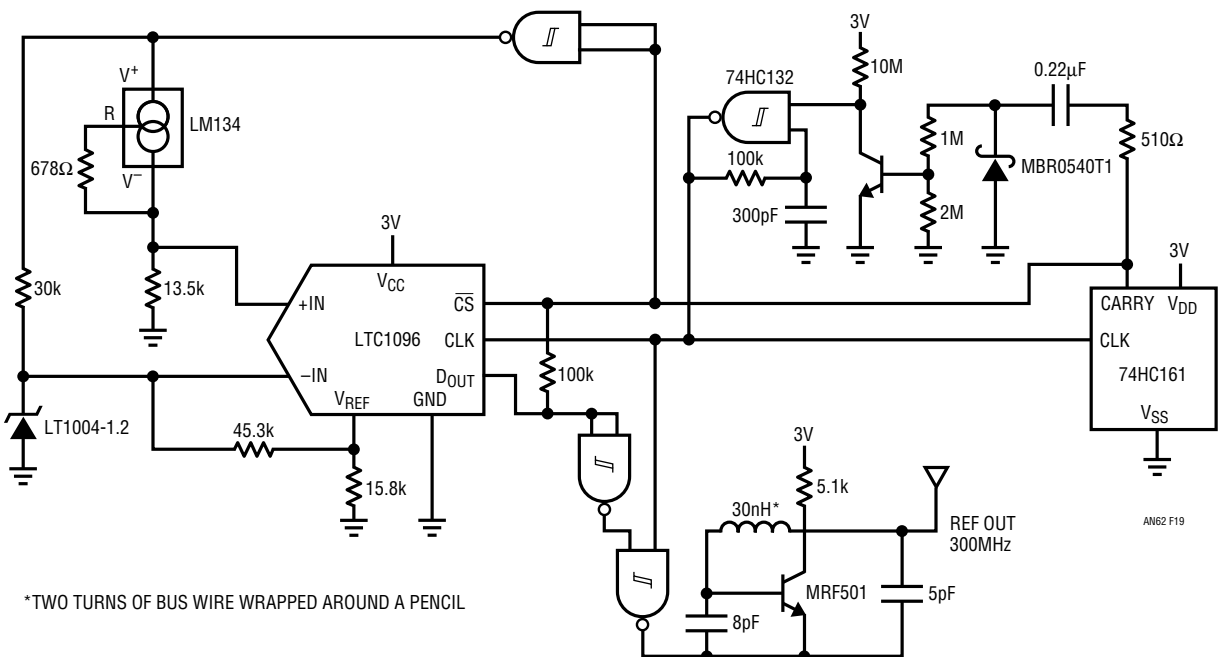
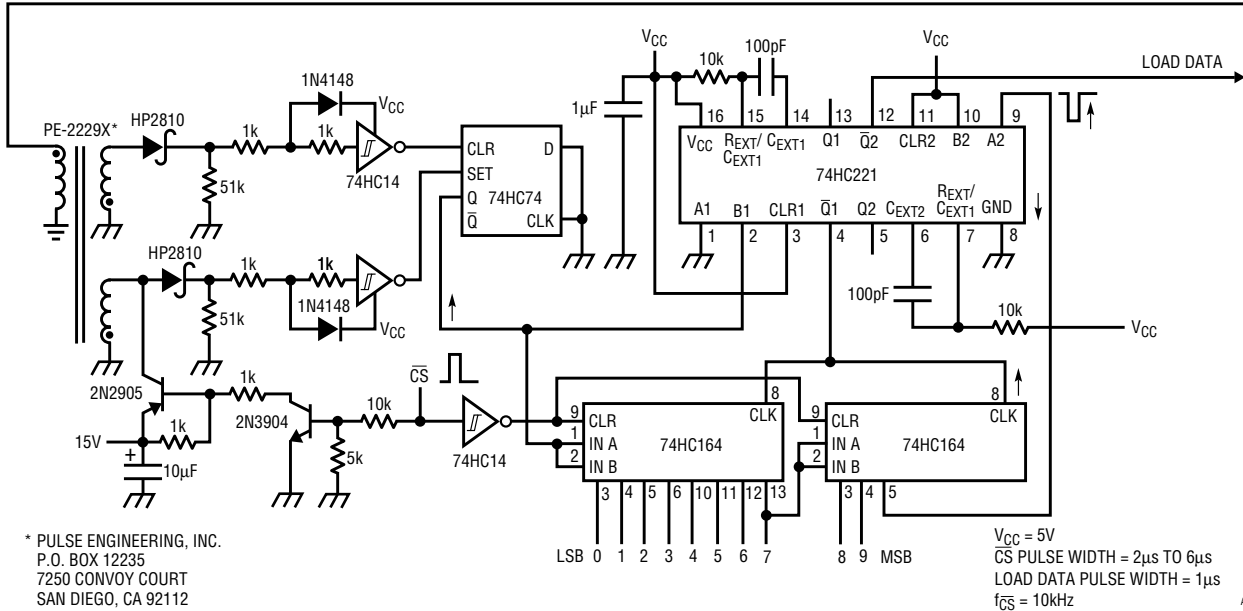
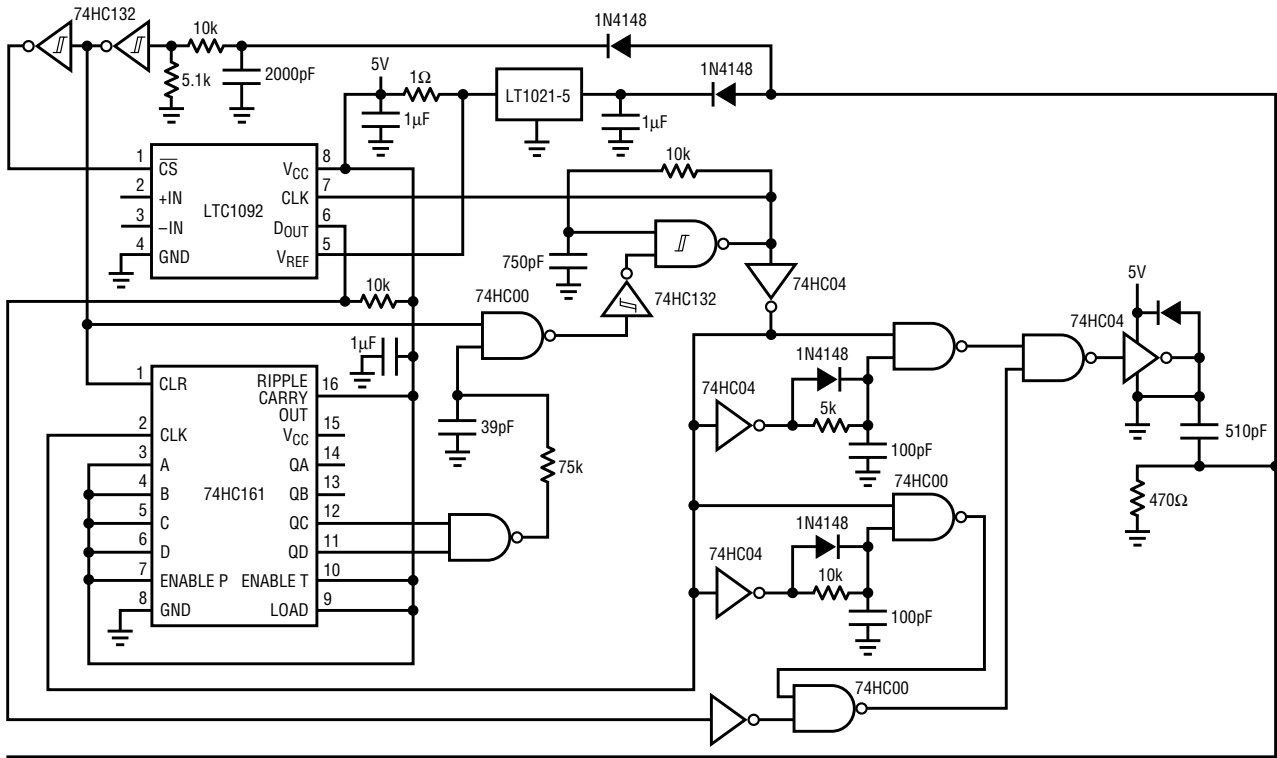

Figure 19. Battery-Powered Digital Thermometer Transmits Over RF-Link

Application Note 62



* PULSE ENGINEERING, INC.
P.O. BOX 12235
7250 CONVOY COURT
SAN DIEGO, CA 92112

TIMING DIAGRAM SHOWING PULSE-WIDTH CODING TECHNIQUE

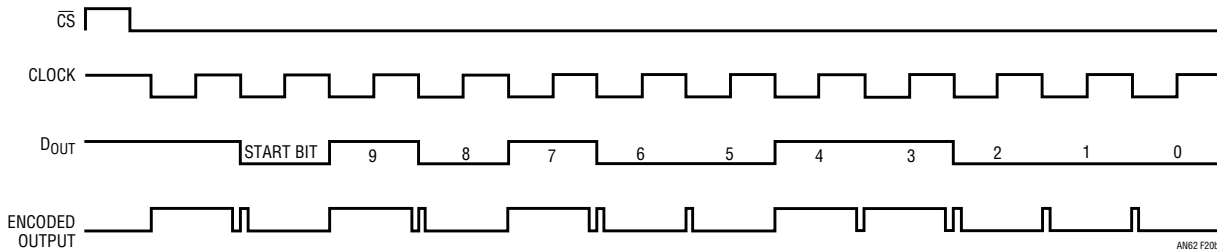
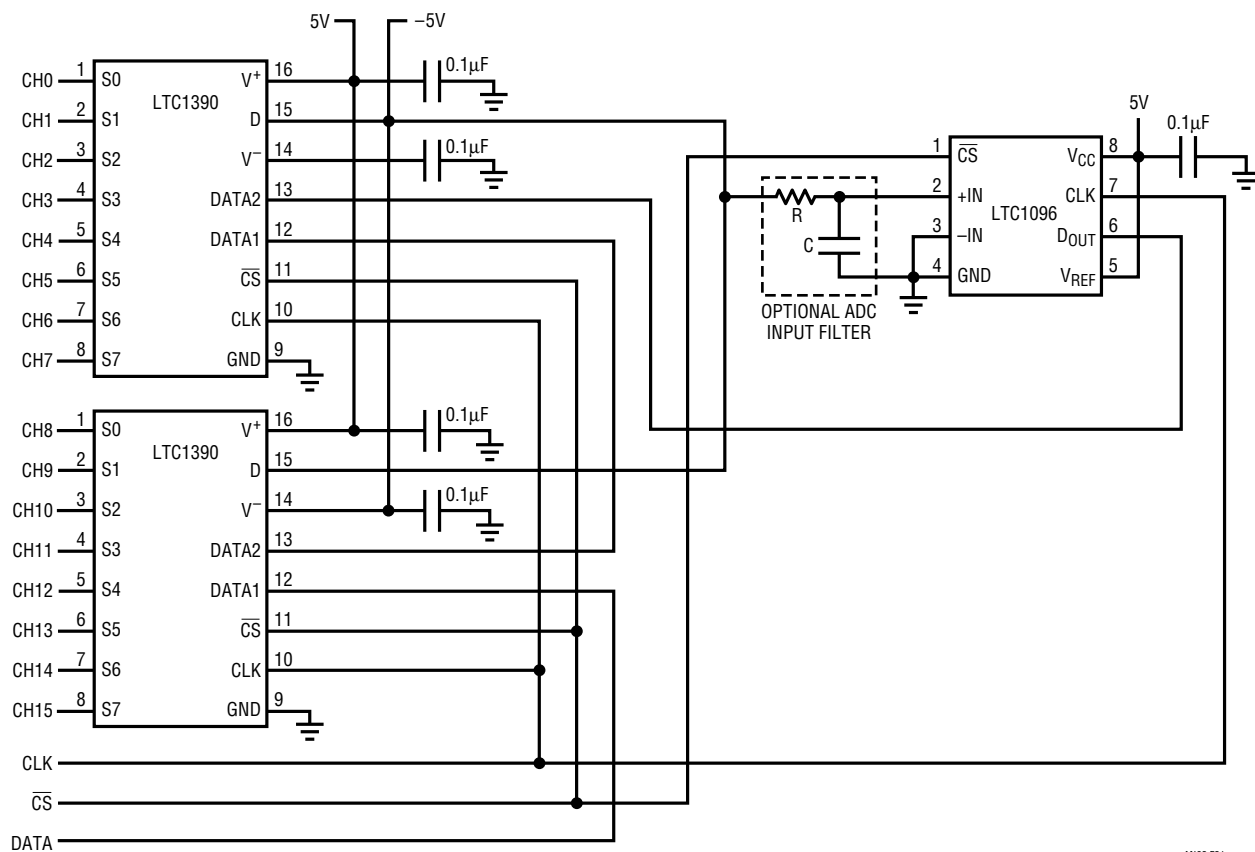

Figure 20. LTC1092 10-Bit Analog-to-Digital Converter Receives Power and Transmits Data Over Two Transformer-Isolated Lines

MISCELLANEOUS CIRCUITS



AN62 F21

Figure 21. Two LTC1390 Cascadable Serially Programmed 8-Channel Multiplexers Provide the Single Channel LTC1096 with 16 Analog Inputs

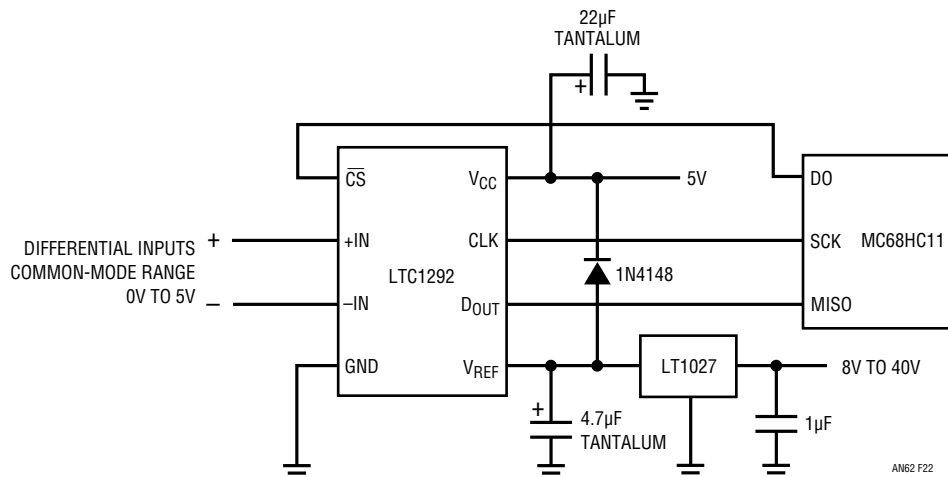

AN62 F22

Figure 22. Small 12-Bit Differential-Input LTC1292 Data Acquisition System Occupies Only 0.35IN² Including Reference and Power Supply Bypass Components

Application Note 62

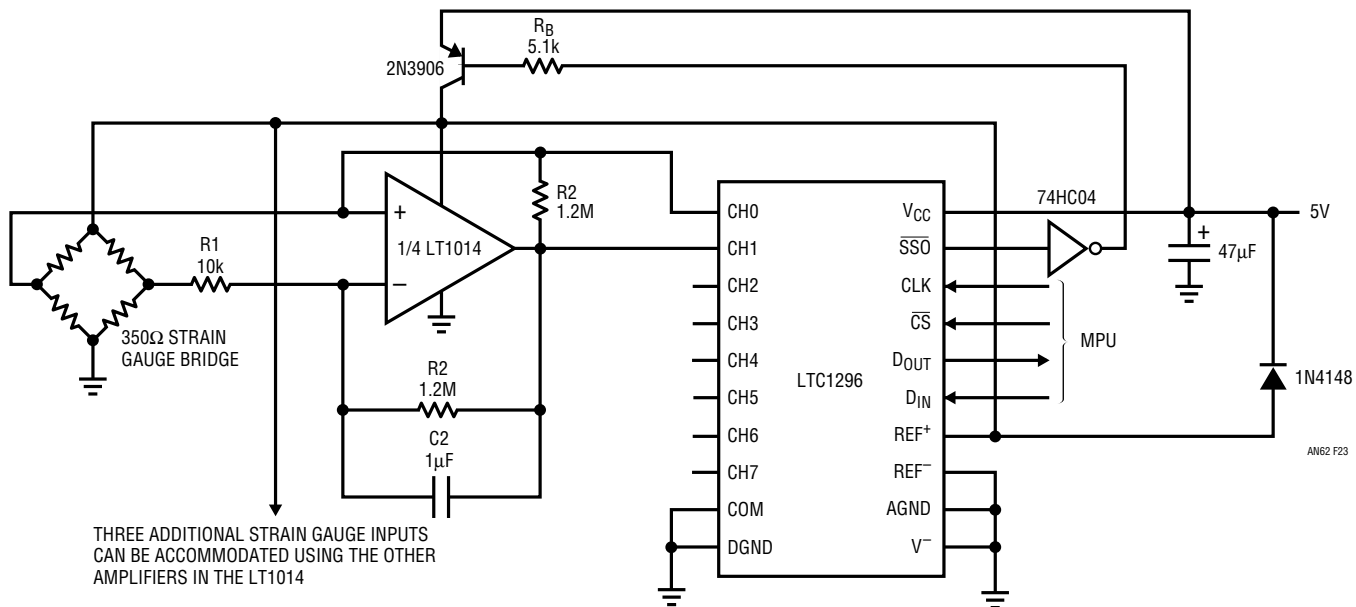

Figure 23. 12-Bit LTC1296 Data Acquisition System Strain Gauge with Bridge-Driver-Power Shutdown

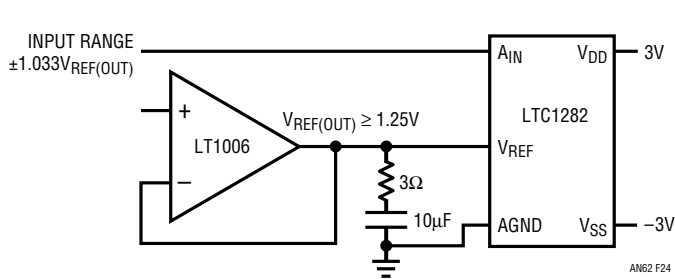

Figure 24. LTC1282 3V Analog-to-Digital Converter with Full-Scale Adjust

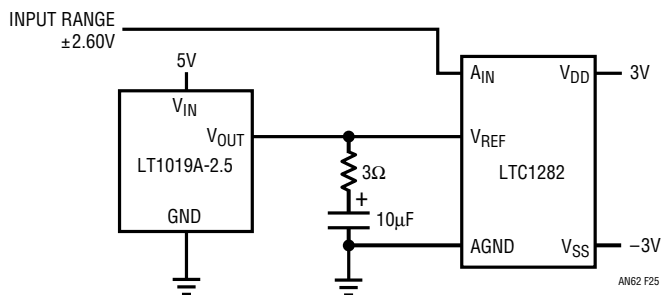

Figure 25. Ultra-Low Full-Scale Drift LTC1282 3V Analog-to-Digital Converter

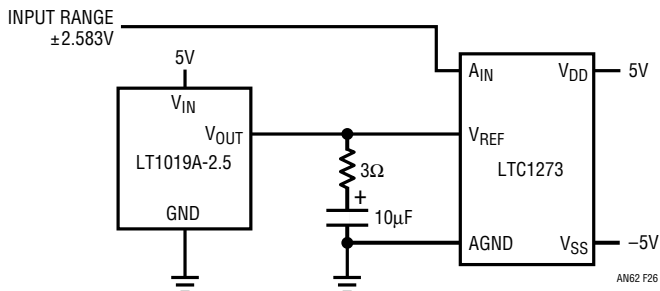

Figure 26. Ultra-Low Full-Scale Drift LTC1273 3V Analog-to-Digital Converter

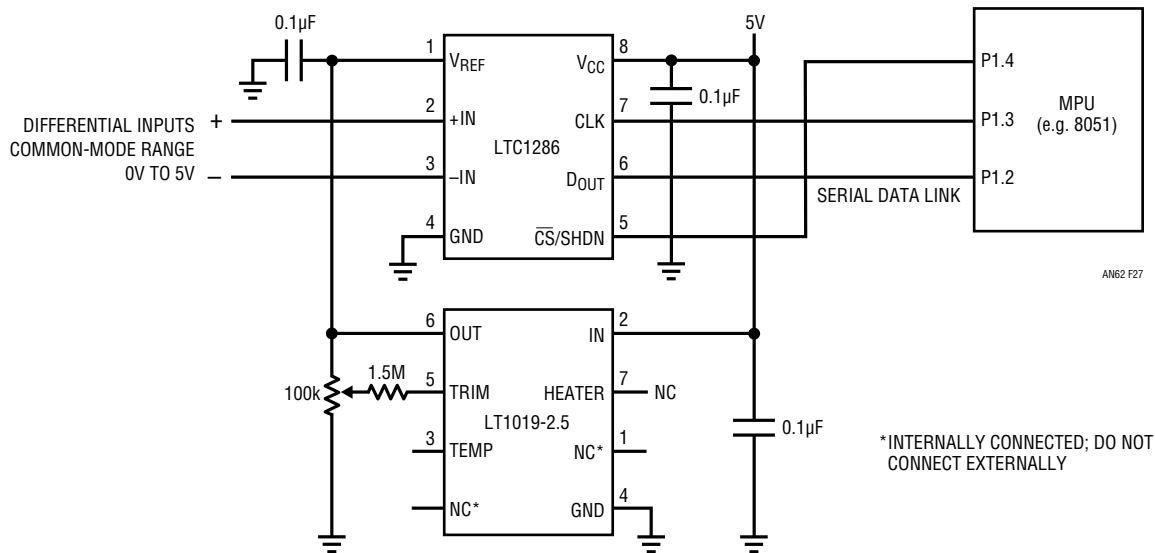

Figure 27. “Tiny” LTC1286 12-Bit Differential-Input Data Acquisition System (In SO Package) and “Tiny” LT1019-2.5 Reference Occupies Only 0.47IN² Including Reference and Power Supply Bypass Components

HARDWARE MICROCONTROLLER INTERFACES

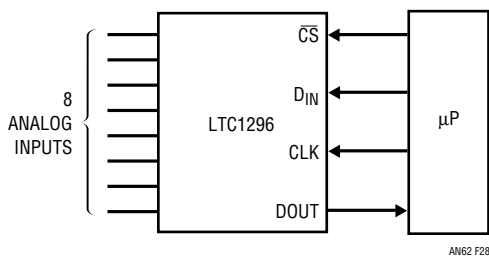

Figure 28. LTC1296 to Microcontroller Hardware Serial Interface

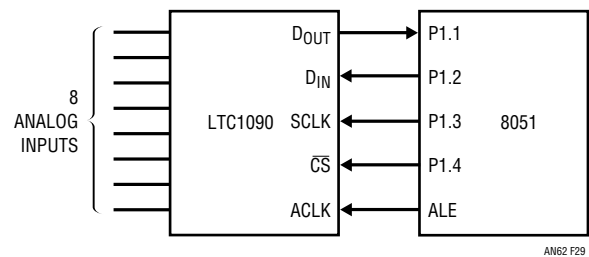

Figure 29. LTC1090* to Intel 8051 Microcontroller Hardware Serial Interface

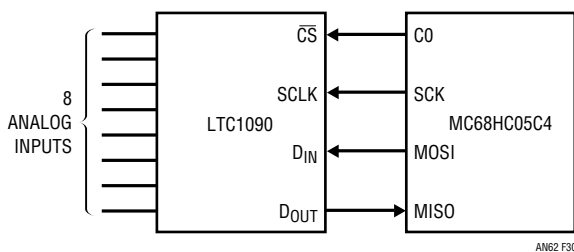

Figure 30. LTC1090* to Motorola MC68HC05C4 Microcontroller Hardware Serial Interface

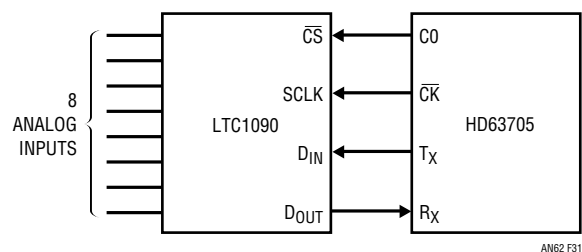

Figure 31. LTC1090* to Hitachi HD63705 Microcontroller Hardware Serial Interface

*Increase resolution from 10 bits to 12 bits with the pin compatible LTC1290.

Application Note 62

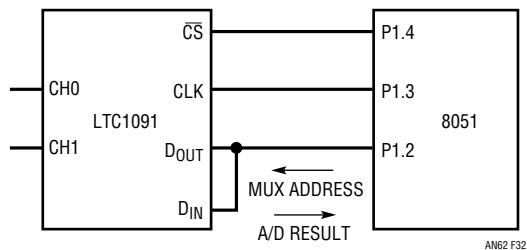

Figure 32. LTC1091* to Intel 8051 Microcontroller Hardware Serial Interface

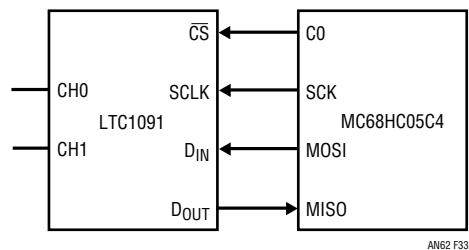

Figure 33. LTC1091* to Motorola MC68HC05C4 Microcontroller Hardware Serial Interface

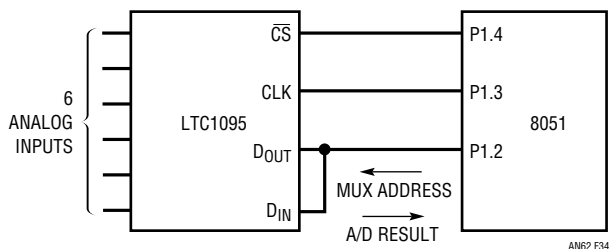

Figure 34. LTC1095 to Intel 8051 Microcontroller Hardware Serial Interface

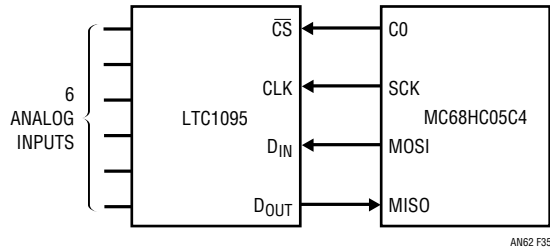

Figure 35. LTC1095 to Motorola MC68HC05C4 Microcontroller Hardware Serial Interface

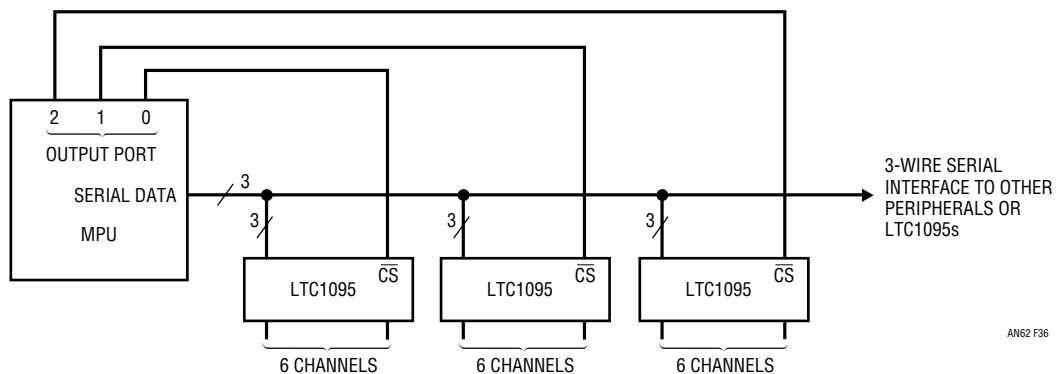

Figure 36. Multiple LTC1095s Sharing One Three-Wire Serial Interface

*Increase resolution from 10 bits to 12 bits with the pin compatible LTC1291.

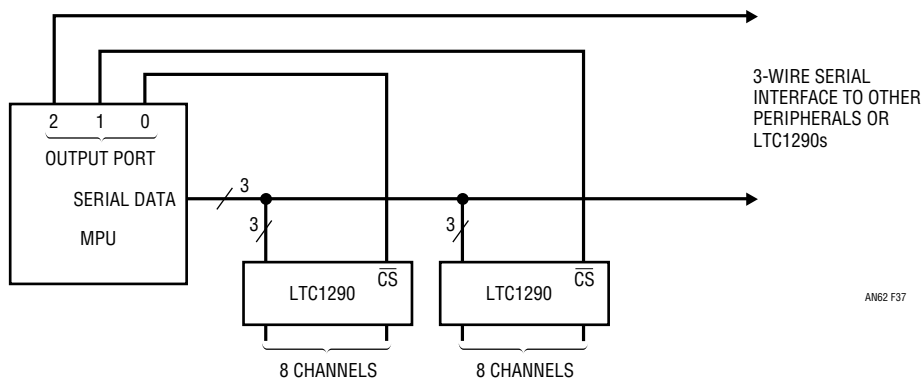

Figure 37. Multiple LTC1290s Sharing One Three-Wire Serial Interface

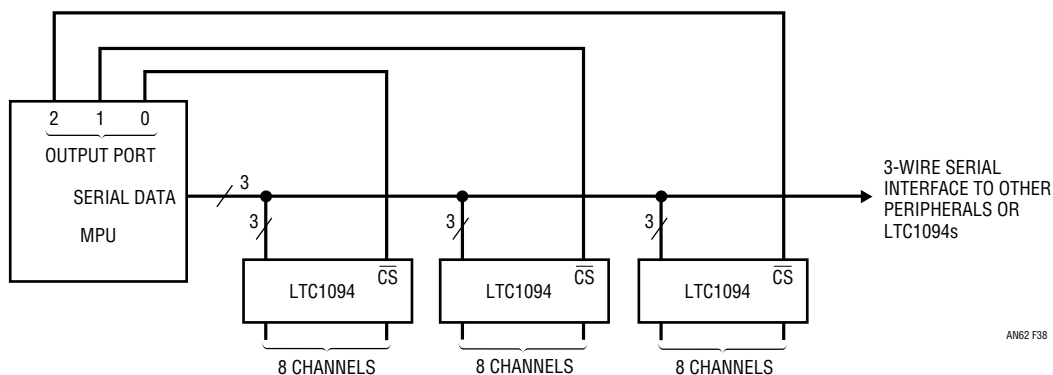

Figure 38. Multiple LTC1094s* Sharing One Three-Wire Serial Interface

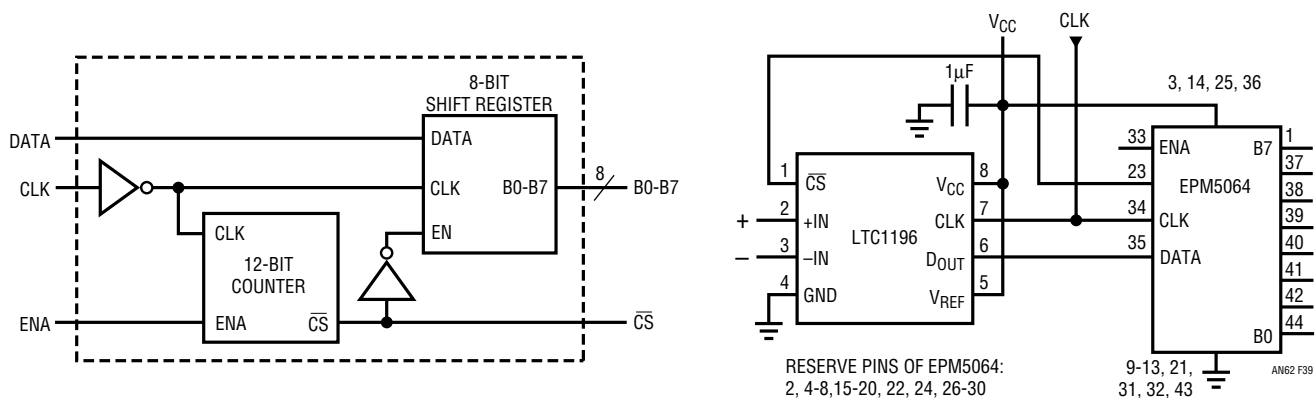

Figure 39. Interfacing the LTC1196 to the Altera EPM5064 PLD

*Increase resolution from 10 bits to 12 bits with the pin compatible LTC1294.

Application Note 62

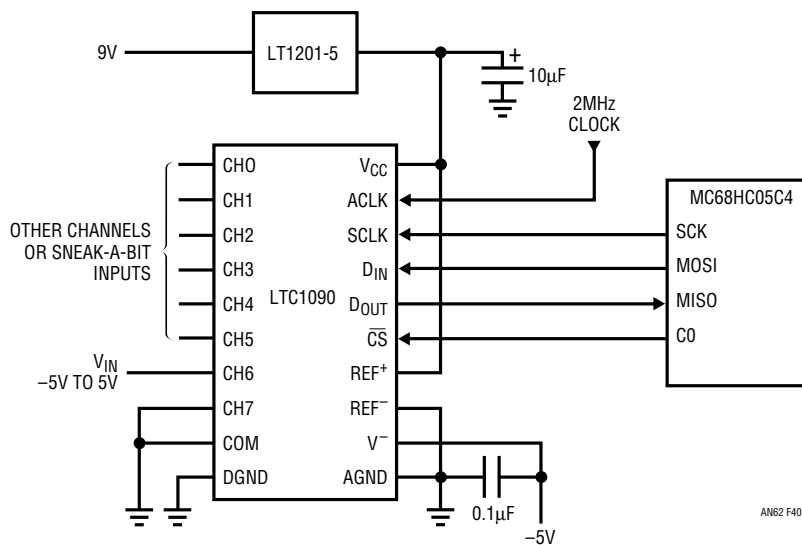
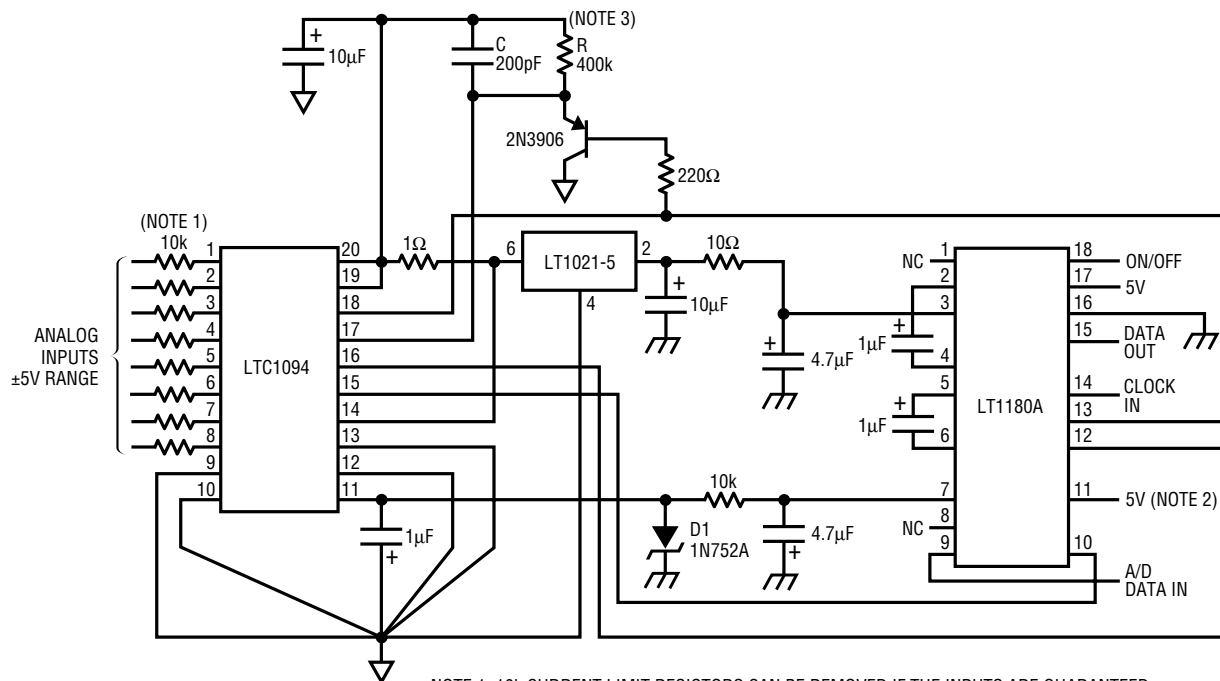



Figure 40. SNEAK-A-BIT Circuit for the LTC1090: 11-Bit Resolution from a 10-Bit ADC

PC SERIAL INTERFACE CIRCUITS



 = CLEAN ANALOG GROUND
 = LOGIC GROUND

NOTE 1: 10k CURRENT LIMIT RESISTORS CAN BE REMOVED IF THE INPUTS ARE GUARANTEED NOT TO EXCEED THE LT1094's SUPPLY VOLTAGES.
 NOTE 2: DRIVER OUTPUTS CAN BE PARALLEL FOR GREATER CURRENT DRIVE.
 NOTE 3: SELECT $R_C = 4t_{\text{Clock}}$, MINIMIZE C.
 NOTE 4: CONNECT THE CLEAN ANALOG GROUND AND THE LOGIC GROUND TOGETHER AT ONLY ONE POINT.

AN62 F41

Figure 41. LTC1094 Analog-to-Digital Converter RS232 Serial Interface Using the LT1180A Dual Driver/Receiver

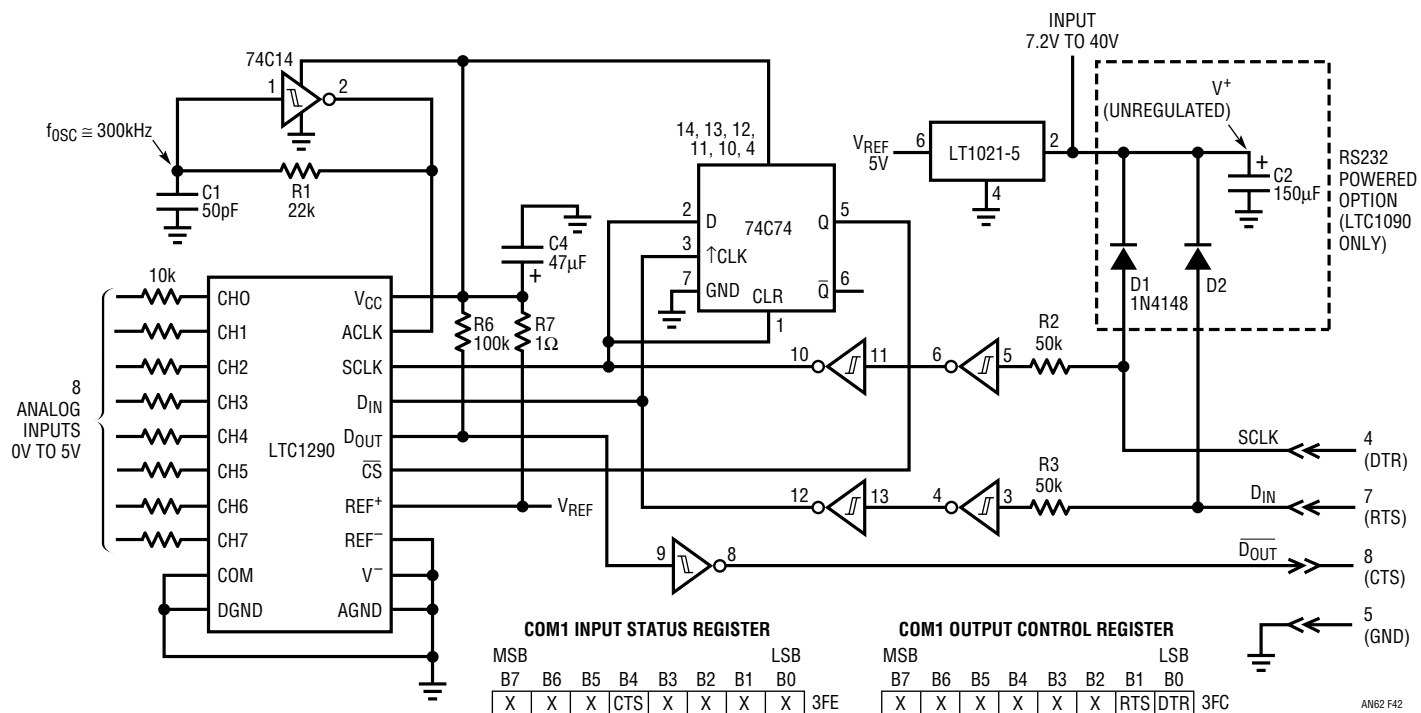

Figure 42. LTC1290 to IBM PC Serial Port

PARALLEL INTERFACE CIRCUITS

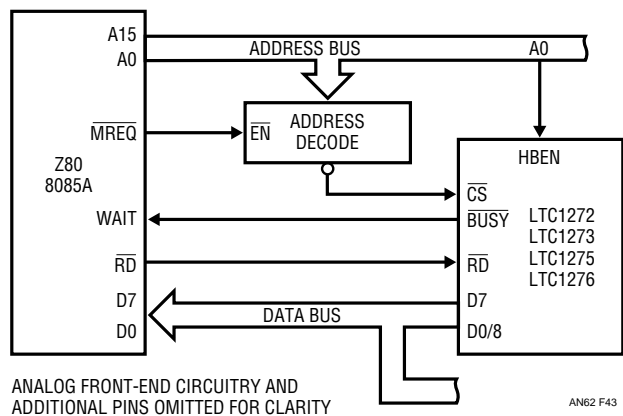

Figure 43. LTC1272/LTC1273/LTC1275/LTC1276 to 8085A/Z80 Microprocessor Hardware Parallel Interface

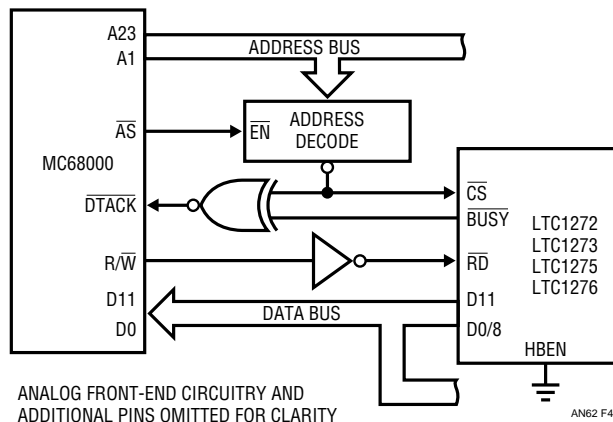

Figure 44. LTC1272/LTC1273/LTC1275/LTC1276 to MC68000 Microprocessor Hardware Parallel Interface

Application Note 62

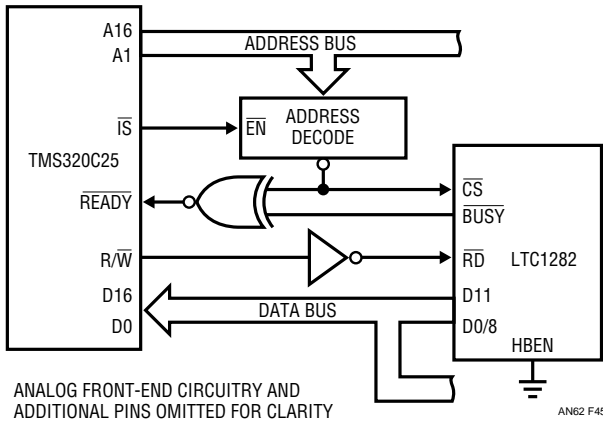

Figure 45. LTC1282 to TMS320C25 DSP Processor Parallel Interface

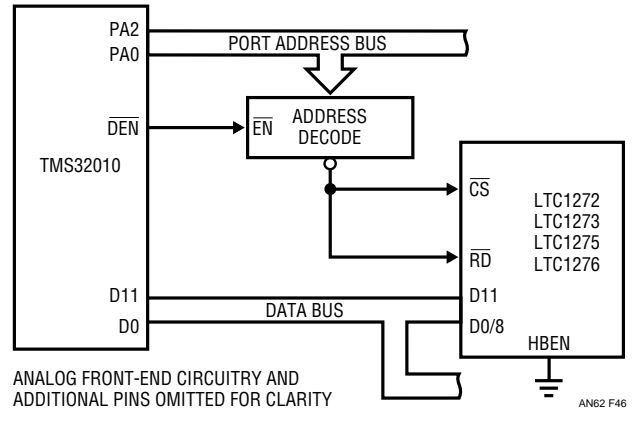

Figure 46. LTC1272/LTC1273/LTC1275/LTC1276 to TMS32010 DSP Processor Parallel Interface

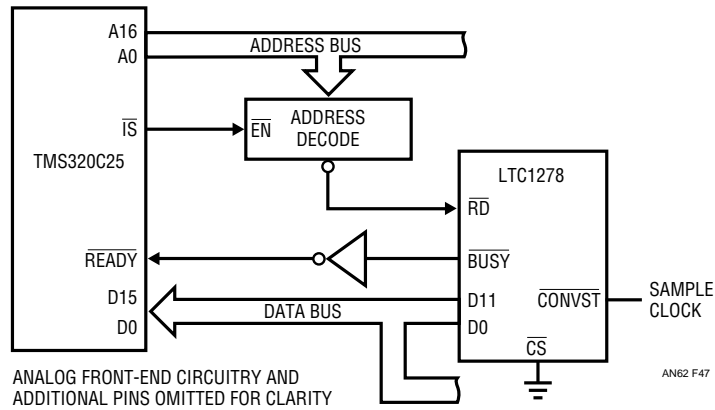

Figure 47. LTC1278 to TMS320C25 DSP Processor Parallel Interface

REFERENCE CIRCUITS

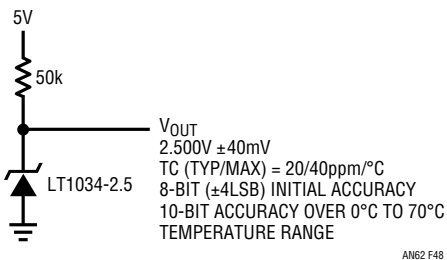

Figure 48. LT1034-2.5 2.5V Voltage Reference

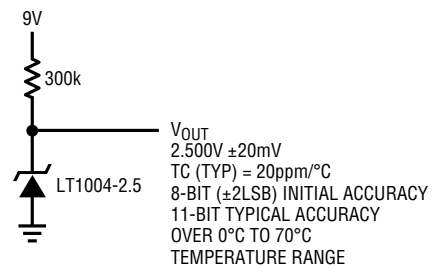

Figure 49. Battery-Powered LT1004-2.5 2.5V Voltage Reference

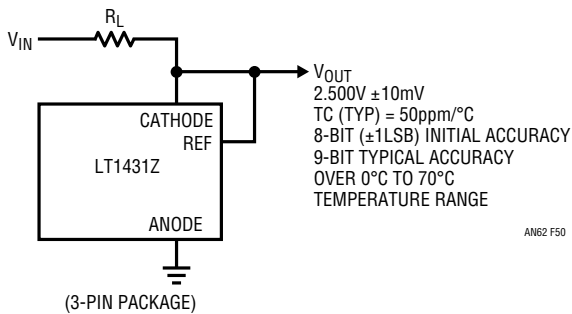

Figure 50. LT1431Z 2.5V Voltage Reference (3-Pin Package)

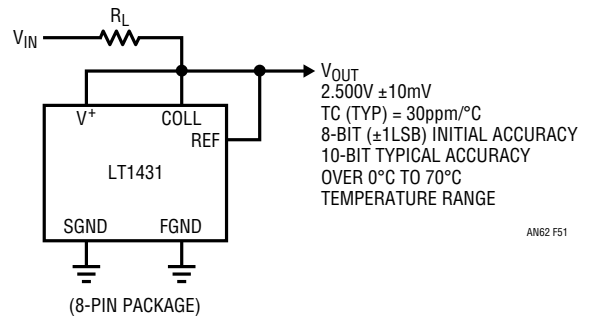

Figure 51. LT1431 2.5V Voltage Reference (8-Pin Package)

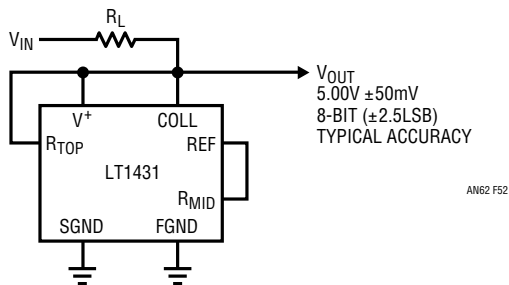

Figure 52. LT1431Z 5V Voltage Reference (8-Pin Package)

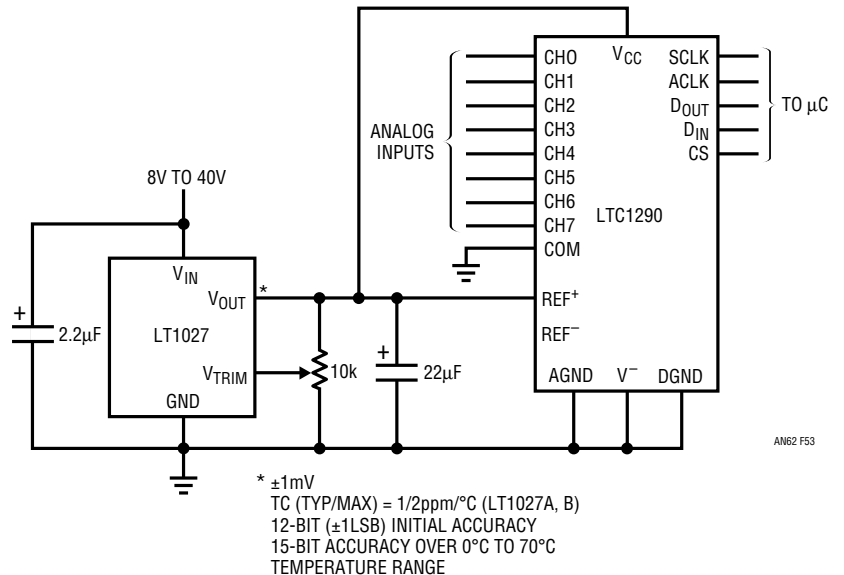

Figure 53. LT1027 12-Bit Accurate 5V Voltage Reference Supplying Input Voltages to the LTC1290's V_{REF} and V_{CC} Pins

ADJUSTABLE REFERENCES

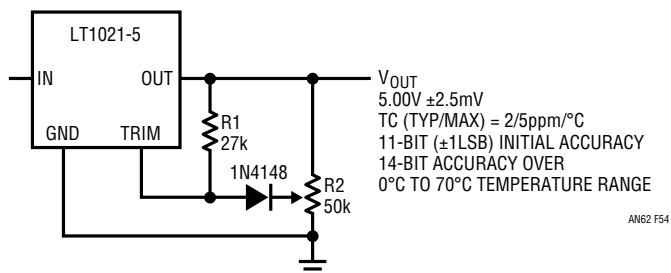

Figure 54. LT1021-5 Adjustable 5V Voltage Reference

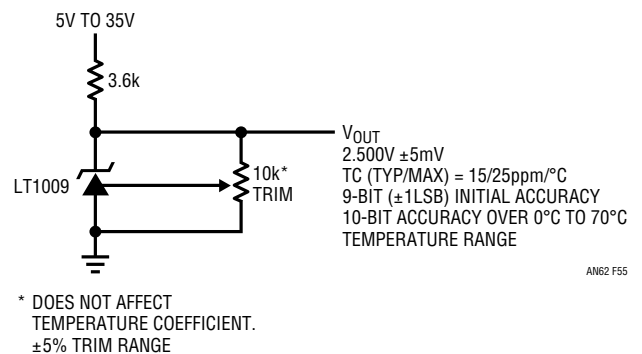
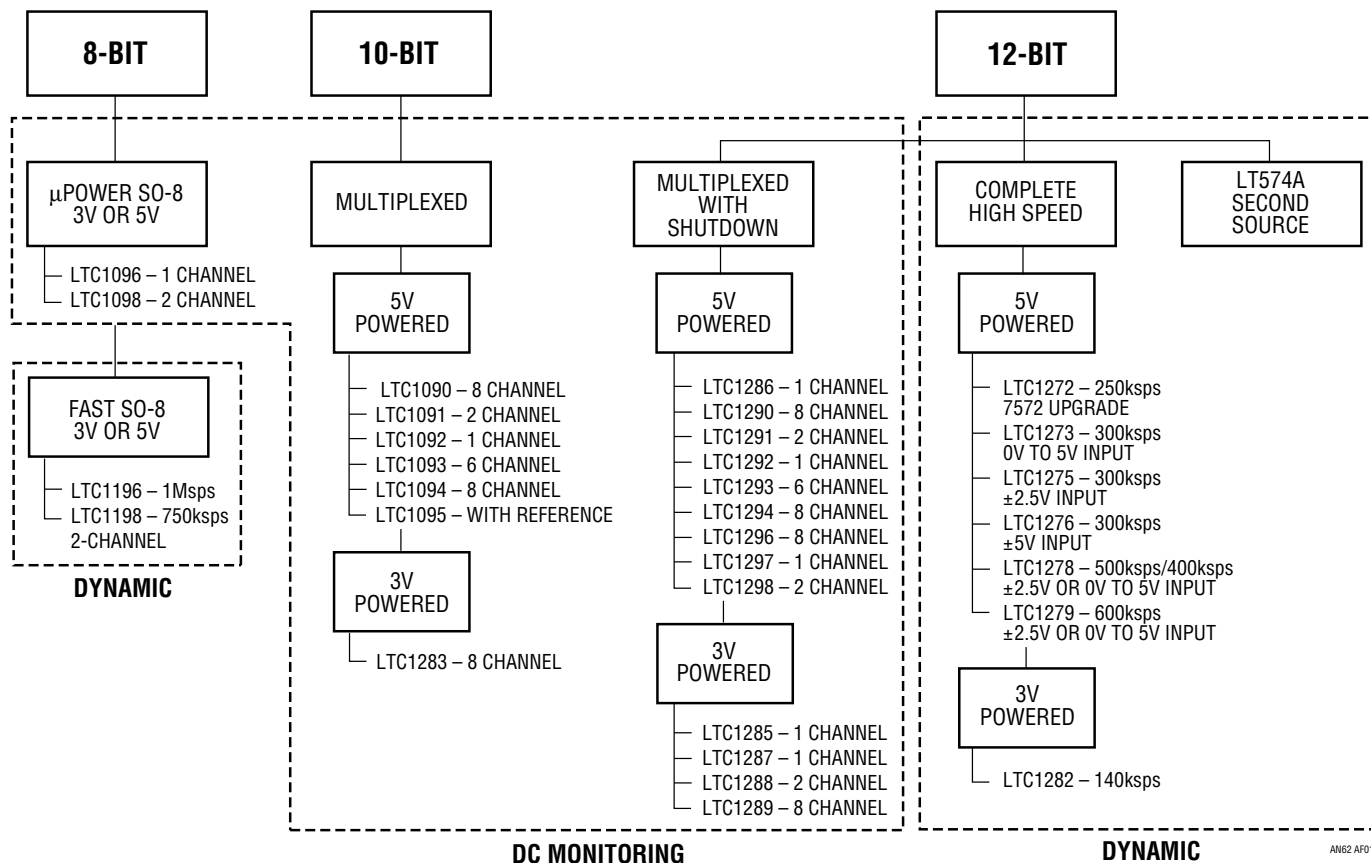

Figure 55. LT1009 2.5V Voltage Reference with ±5% Trim Range

Application Note 62

APPENDIX A



AN62 AFG1

Analog-to-Digital Converter Selection Guide

PART NUMBER	DESCRIPTION	RESOLUTION	TOTAL UNADJUSTED ERROR	SAMPLE RATE	VOLTAGE SUPPLY	MAXIMUM SUPPLY CURRENT	PKGS AVAIL	IMPORTANT FEATURES
LTC1090C,M	10-Bit, Serial I/O, A/D Converter with 8-Channel Multiplexer. Full Duplex Serial Interface.	10 Bits	±0.5LSB (LTC1090A) Over Full Temperature Range	35ksps	5V, 10V, or ±5V	2.5mA	J, N, S	10-Bit ADC with Built-In 8-Channel Analog MUX and Sample-and-Hold. Compatible with All Microprocessors' Serial Ports. Software Configurable Bipolar or Unipolar Operation. Full Duplex Serial I/O.
LTC1091C,M	10-Bit, 8-Pin Serial I/O, A/D Converter with 2-Channel Analog Multiplexer.	10 Bits	±0.5LSB (LTC1091A) Over Full Temperature Range	31ksps	5V or 10V	3.5mA	J8, N8	10-Bit ADC with Built-In 2-Channel Analog MUX and Sample-and-Hold. Compatible with All Microprocessors' Serial Ports. Unipolar Operation.
LTC1092C,M	10-Bit, 8-Pin, A/D Converter with Serial Output.	10 Bits	±0.5LSB (LTC1092A) Over Full Temperature Range	38ksps	5V or 10V	2.5mA	J8, N8	Separate Reference Pin Allows Reduced Span (Down to 220mV) Operation. Unipolar ADCs Are Performed on a Differential Input Pair. Compatible with All Microprocessors' Serial Ports.
LTC1093C,M	10-Bit, Serial I/O, A/D Converter with 6-Channel Multiplexer.	10 Bits	±0.5LSB (LTC1093A) Over Full Temperature Range	26ksps	5V, 10V, or ±5V	2.5mA	J, N, S	10-Bit ADC with Built-In 6-Channel Analog MUX and Sample-and-Hold. Compatible with All Microprocessors' Serial Ports. Software Configurable Bipolar or Unipolar Operation. Half Duplex Serial I/O.

Application Note 62

PART NUMBER	DESCRIPTION	RESOLUTION	TOTAL UNADJUSTED ERROR	SAMPLE RATE	VOLTAGE SUPPLY	MAXIMUM SUPPLY CURRENT	PKGS. AVAIL.	IMPORTANT FEATURES
LTC1094C,M	10-Bit, Serial I/O, A/D Converter System with 8-Channel Multiplexer.	10 Bits	$\pm 0.5\text{LSB}$ (LTC1094A) Over Full Temperature Range	26ksps	5V, 10V, or $\pm 5\text{V}$	2.5mA	J, N	10-Bit ADC with Built-In 8-Channel Analog MUX and Sample-and-Hold. Compatible with All Microprocessors' Serial Ports. Software Configurable Bipolar or Unipolar Operation. Half Duplex Serial I/O.
LTC1095C,M	10-Bit, Serial I/O, A/D Converter with 6-Channel Multiplexer and 5V Buried Zener Reference.	10 Bits	$\pm 0.15\%$ FSR	26ksps	7.2V to 10V	3.7mA	J	10-Bit ADC with Built-In 6-Channel Analog MUX, Sample-and-Hold, and 5V Buried Zener Reference. Compatible with All Microprocessors' Serial Ports. Software Configurable Bipolar or Unipolar Operation. Half Duplex Serial I/O.
LTC1096C	8-Bit, 16 μs , Micropower, Sampling A/D Converter with Serial I/O and Differential Input.	8 Bits	$\pm 0.5\text{LSB}$ (LTC1096A) Over Full Temperature Range	33ksps	3V to 9V	180 μA , 3 μA During Shutdown	N8, S8	Single Differential Input, Sample-and-Hold with Single-Ended Inputs. Ultra-Low Power, Automatic Power-Down Mode.
LTC1098C	8-Bit, 16 μs , Micropower, Sampling A/D Converter with Serial I/O and 2-Channel MUX.	8 Bits	$\pm 0.5\text{LSB}$ (LTC1098A) Over Full Temperature Range	33ksps	3V to 9V	230 μA , 3 μA During Shutdown	N8, S8	2-Channel Multiplexer, Sampling ADC. Ultra-Low Power, Automatic Power-Down Mode.
LTC1099C,M	8-Bit, 2 μs A/D Converter with Built-in Sample-and-Hold. Parallel Output.	8 Bits	$\pm 1\text{LSB}$ Over Full Temperature Range	256ksps	5V	15mA	J, N, S	Built-in Sample-and-Hold Allows Direct Conversion of 5V _{P-P} Signals up to 156kHz. Pin Compatible with ADC0820 and AD7820.
LTC1196C	8-Bit, 8-Pin, Serial I/O, 600ns, 1MHz, Sampling A/D Converter with Automatic Power-Down.	8 Bits	$\pm 0.5\text{LSB}$ Over Full Temperature Range	1Msps	3V to 6V	10mA	N, S	8-Bit ADC with Built-In Sample-and-Hold. Compatible with All Microprocessors' Serial Ports. Full Duplex Serial I/O.
LTC1198C	8-Bit, 8-Pin, Serial I/O, 600ns, 750kHz, Sampling A/D Converter with 2-Channel Analog MUX and Automatic Power-Down.	8 Bits	$\pm 0.5\text{LSB}$ Over Full Temperature Range	750ksps	3V to 6V	10mA, 3 μA During Shutdown	N, S	8-Bit ADC with Built-In Sample-and-Hold. Compatible with All Microprocessors' Serial Ports. Full Duplex Serial I/O. 2-Channel Analog MUX and Automatic Power-Down.
LTC1272C,M	12-Bit, 3 μs , 250ksps Sampling A/D Converter with Parallel Output. Single 5V Supply. Input Range: $0\text{V} \leq V_{\text{IN}} \leq 5\text{V}$.	12 Bits	$\pm 0.5\text{LSB}$ Linearity, $\pm 1\text{LSB}$ Differential Nonlinearity, and $\pm 4\text{LSB}$ Offset Error Over Full Temperature Range. $\pm 10\text{LSB}$ Full-Scale Error. 72dB SINAD and -82dB THD at $f_{\text{IN}} = 10\text{kHz}$.	250ksps (111ksps also available)	5V	30mA	J, N, S	Single Supply 12-Bit ADC with Built-In Sample-and-Hold and 250ksps Conversion Rate. Built-In 2.42V Reference. Plug-In Upgrade for AD7572. Operates with or without -15V Supply Required by AD7572.
LTC1273C,M	12-Bit, 2.7 μs , 300ksps Sampling A/D Converter with Parallel Output. Single 5V Supply. Input Range: $0\text{V} \leq V_{\text{IN}} \leq 5\text{V}$.	12 Bits	$\pm 0.5\text{LSB}$ Linearity, $\pm 0.75\text{LSB}$ Differential Nonlinearity, and $\pm 4\text{LSB}$ Offset Error Over Full Temperature Range. $\pm 10\text{LSB}$ Full-Scale Error. 70dB SINAD and -74dB THD at $f_{\text{IN}} = 150\text{kHz}$.	300ksps	5V	25mA	J, N, S	Single Supply 12-Bit ADC with Built-In Sample-and-Hold, Internal Clock, and 300ksps Conversion Rate. Built-In 2.42V Reference.
LTC1275C	12-Bit, 2.7 μs , 300ksps, Sampling A/D Converter with Parallel Output. Split $\pm 5\text{V}$ Supply. Input Range: $-2.5\text{V} \leq V_{\text{IN}} \leq 2.5\text{V}$.	12 Bits	$\pm 0.5\text{LSB}$ Linearity, $\pm 0.75\text{LSB}$ Differential Nonlinearity, and $\pm 4\text{LSB}$ Offset Error Over Full Temperature Range. 70dB SINAD and -74dB THD at $f_{\text{IN}} = 150\text{kHz}$. $\pm 10\text{LSB}$ Full-Scale Error.	300ksps	$\pm 5\text{V}$	25mA	N, S	Split Supply 12-Bit ADC with Built-In Sample-and-Hold, Internal Clock, and 300ksps Conversion Rate. Built-In 2.42V Reference.

Application Note 62

PART NUMBER	DESCRIPTION	RESOLUTION	TOTAL UNADJUSTED ERROR	SAMPLE RATE	VOLTAGE SUPPLY	MAXIMUM SUPPLY CURRENT	PKGS. AVAIL.	IMPORTANT FEATURES
LTC1276C	12-Bit, 2.7 μ s, 300ksps Sampling A/D Converter with Parallel Output. Split $\pm 5V$ Supply. Input Range: $-5V \leq V_{IN} \leq 5V$.	12 Bits	± 0.5 LSB Linearity, ± 0.75 LSB Differential Nonlinearity, and ± 4 LSB Offset Error Over Full Temperature Range. 70dB SINAD and -74 dB THD at $f_{IN} = 150$ kHz. ± 10 LSB Full-Scale Error.	300ksps	$\pm 5V$	25mA	N, S	Split Supply 12-Bit ADC with Built-In Sample-and-Hold, Internal Clock, and 300ksps Conversion Rate. Built-In 2.42V Reference.
LTC1278C,I	12-Bit, 1.6 μ s, 500ksps Sampling A/D Converter with Parallel Output. Input Range with Split $\pm 5V$ Supply: $-2.5V \leq V_{IN} \leq 2.5V$; with 5V Supply: $0V \leq V_{IN} \leq 5V$.	12 Bits	± 1 LSB Linearity, ± 1 LSB Differential Nonlinearity, and ± 6 LSB Offset Error Over Full Temperature Range. 70dB SINAD and -74 dB THD at $f_{IN} = 250$ kHz. ± 15 LSB Gain Error.	500ksps (400ksps also available)	5V or $\pm 5V$	30mA, 3mA During Shutdown	N, S	Single or Split Supply 12-Bit ADC with Built-In Sample-and-Hold, Internal Clock, and 500ksps Conversion Rate. Built-In 2.42V Reference. Guaranteed 70dB SINAD and -78 THD at 100kHz Input Frequency Over Temperature.
LTC1279C,I	12-Bit, 1.4 μ s, 600ksps Sampling A/D Converter with Parallel Output. Input Range with 5V Supply: $0V \leq V_{IN} \leq 5V$; with Split $\pm 5V$ Supply: $-2.5V \leq V_{IN} \leq 2.5V$.	12 Bits	± 1 LSB Linearity, ± 1 LSB Differential Nonlinearity, and ± 6 LSB Offset Error Over Full Temperature Range. 70dB SINAD and -74 dB THD at $f_{IN} = 300$ kHz. ± 15 LSB Gain Error.	600ksps	5V or $\pm 5V$	20mA, 3mA During Shutdown	N, S	Single or Split Supply 12-Bit ADC with Built-In Sample-and-Hold, Internal Clock, and 600ksps Conversion Rate. Built-In 2.42V Reference. Guaranteed 70dB SINAD and -78 dB THD at 100kHz Input Frequency Over Temperature.
LTC1282C	12-Bit, 6 μ s, 140ksps Sampling A/D Converter with Parallel Output. Input Range with Single 3V Supply: $0V \leq V_{IN} \leq 2.5V$; with Split $\pm 3V$ Supply: $-1.25V \leq V_{IN} \leq 1.25V$.	12 Bits	± 0.5 LSB Linearity, ± 0.75 LSB Differential Nonlinearity, and ± 4 LSB Offset Error Over Full Temperature Range. 69dB SINAD and -77 dB THD at $f_{IN} = 70$ kHz. ± 10 LSB Full-Scale Error.	140ksps	3V or $\pm 3V$	8mA	N, S	Single or Split Supply 12-Bit ADC with a 2.7V Guaranteed Minimum Supply Voltage. Complete with Sample-and-Hold, Internal Clock and a 25ppm/ $^{\circ}C$ 1.2V Reference.
LTC1283C	10-Bit, 44 μ s, 3.3V or $\pm 3.3V$ Sampling A/D Converter with Serial Output. Input Range with Split $\pm 3.3V$ Supply: $-2.5V \leq V_{IN} \leq 2.5V$; with 3.3V Supply: $0V \leq V_{IN} \leq 2.5V$.	10 Bits	± 0.5 LSB Linearity and ± 0.5 LSB Offset Error Over Full Temperature Range.	15ksps	3.3V or $\pm 3.3V$	350 μ A	N, S	3.3V or $\pm 3.3V$ Supply 10-Bit ADC with Built-In Sample-and-Hold. 10-Bit Unipolar or 9-Bit + Sign Bipolar Serial Output. Compatible with All Microprocessors' Serial Ports. Full Duplex Serial I/O.
LTC1285C	12-Bit, 8-Pin Serial I/O, 160 μ A (Typ) 3V Sampling A/D Converter with Automatic Power-Down and Differential Analog Input.	12 Bits	± 2 LSB Linearity, ± 0.75 LSB Differential Nonlinearity, ± 3 LSB Offset, and ± 8 LSB Full-Scale Error Over Full Temperature Range.	7.5ksps	3V	320 μ A, 3 μ A During Shutdown	N, S	12-Bit ADC with Built-In Sample-and-Hold. Operates on 3V Supply Voltage. Compatible with All Microprocessors' Serial Ports. Automatic Power-Down.
LTC1286C,I	12-Bit, 8-Pin Serial I/O, 250 μ A (Typ) Sampling A/D Converter with Automatic Power-Down.	12 Bits	± 2 LSB Linearity, ± 0.75 LSB Differential Nonlinearity, ± 3 LSB Offset, and ± 8 LSB Full-Scale Error Over Full Temperature Range.	12.5ksps	5V to 9V	500 μ A, 3 μ A During Shutdown	N, S	12-Bit ADC with Built-In Sample-and-Hold. Compatible with All Microprocessors' Serial Ports. Automatic Power Down.
LTC1287C,I	12-Bit, 33 μ s, 3.3V Sampling A/D Converter with Serial Output. Input Range with 3.3V Supply: $0V \leq V_{IN} \leq 3.3V$.	12 Bits	± 0.5 LSB Linearity, ± 3 LSB Offset, and ± 0.5 LSB Full-Scale Error Over Full Temperature Range.	30ksps	2.7V to 3.3V	5mA	J, N,	12-Bit ADC with Built-In Sample-and-Hold. Guaranteed Operation on a 2.7V Supply. Compatible with All Microprocessors' Serial Ports.

Application Note 62

PART NUMBER	DESCRIPTION	RESOLUTION	TOTAL UNADJUSTED ERROR	SAMPLE RATE	VOLTAGE SUPPLY	MAXIMUM SUPPLY CURRENT	PKGS. AVAIL.	IMPORTANT FEATURES
LLTC1288C	12-Bit, 8-Pin, Serial I/O, 210 μ A (Typ) 3V Sampling A/D Converter with Automatic Power-Down, Differential Analog Input and 2-Channel Multiplexer.	12 Bits	± 2 LSB Linearity, ± 0.75 Differential Nonlinearity, ± 3 LSB Offset, and ± 8 LSB Full-Scale Error Over Full Temperature Range.	6.6ksps	3V	390 μ A, 3 μ A During Shutdown	N, S	12-Bit ADC with Built-In Sample-and-Hold. Operates on 3V Supply Voltage. Compatible with All Microprocessors' Serial Ports. Automatic Power-Down. 2-Channel Multiplexer.
LTC1289C,I	12-Bit, 40 μ s, 3.3V or ± 3.3 V, Sampling A/D Converter with 8-Channel MUX and Serial Output. Input Range with Split ± 3.3 V Supply: $-3.3\text{V} \leq V_{IN} \leq 3.3\text{V}$; with 3.3V Supply: $0\text{V} \leq V_{IN} \leq 3.3\text{V}$.	12 Bits	± 0.5 LSB Linearity, ± 1.5 LSB Offset, and ± 0.5 LSB Full-Scale Error Over Full Temperature Range.	25ksps	2.7V to 3.3V or ± 2.7 V to ± 3.3 V	5mA, 10 μ A During Shutdown	J, N, S	12-Bit ADC with Built-In Sample-and-Hold and 8-Channel MUX. Guaranteed Operation on a 2.7V Supply. Compatible with All Microprocessors' Serial Ports. Automatic Power-Down.
LTC1290C,I,M	12-Bit, 8-Pin Serial I/O, A/D Converter with 8-Channel Multiplexer. Full Duplex Serial Interface.	12 Bits	± 0.5 LSB Linearity, ± 1.5 LSB Offset, and ± 0.5 LSB Full-Scale Error Over Full Temperature Range.	50ksps	5V or ± 5 V	12mA	J, N, S	12-Bit ADC with Built-In 8-Channel Analog MUX and Sample-and-Hold. Compatible with All Microprocessors' Serial Ports. Software Configurable Bipolar or Unipolar Operation. Full Duplex Serial I/O.
LTC1291C,I,M	12-Bit, 12 μ s, 5V, Sampling A/D Converter with Serial Output. Input Range: $0\text{V} \leq V_{IN} \leq 5\text{V}$.	12 Bits	± 0.5 LSB Linearity, ± 3 LSB Offset, and ± 1 LSB Full-Scale Error Over Full Temperature Range.	54ksps	2.7V to 3.3V or ± 3.3 V	12mA, 10 μ A During Shutdown	J, N	12-Bit ADC with Built-In Sample-and-Hold. Compatible with All Microprocessors' Serial Ports. Automatic Power-Down.
LTC1292C,I,M	12-Bit, 8-Pin A/D Converter Serial Output.	12 Bits	± 0.5 LSB Linearity, ± 3 LSB Offset, and ± 0.5 LSB Full-Scale Error Over Full Temperature Range.	60ksps	5V	12mA	J, N	12-Bit ADC, Unipolar Conversion of Single Differential Input. Separate Reference Pin Allows Reduced Span. Compatible with All Microprocessors' Serial Ports.
LTC1293C,I,M	12-Bit, Serial I/O, A/D Converter System with 6-Channel Multiplexer.	12 Bits	± 0.5 LSB Linearity, ± 3 LSB Offset, and ± 0.5 LSB Full-Scale Error Over Full Temperature Range.	46ksps	5V or ± 5 V	12mA	J, N	12-Bit ADC with Built-In 6-Channel MUX and Sample-and-Hold. Compatible with All Microprocessors' Serial Ports. Software Configurable Bipolar or Unipolar Operation. Full Duplex Serial I/O.
LTC1294C,I,M	12-Bit, Serial I/O, A/D Converter System with 8-Channel Multiplexer.	12 Bits	± 0.5 LSB Linearity, ± 3 LSB Offset, and ± 0.5 LSB Full-Scale Error Over Full Temperature Range.	46ksps	5V or ± 5 V	12mA	J, N	12-Bit ADC with Built-In 8-Channel MUX and Sample-and-Hold. Compatible with All Microprocessors' Serial Ports. Software Configurable Bipolar or Unipolar Operation. Half Duplex Serial I/O.
LTC1296C,I,M	12-Bit, Serial I/O, A/D Converter System with 8-Channel Multiplexer.	12 Bits	± 0.5 LSB Linearity, ± 3 LSB Offset, and ± 0.5 LSB Full-Scale Error Over Full Temperature Range.	46ksps	5V or ± 5 V	12mA, 10 μ A During Shutdown	J, N	12-Bit ADC with Built-In 8-Channel MUX and Sample-and-Hold. Compatible with All Microprocessors' Serial Ports. Software Configurable Bipolar or Unipolar Operation. Programmable Power-Down Includes a System Shutdown Output.
LTC1297C,I,M	12-Bit, 20 μ s, 5V, Sampling A/D Converter with Differential Input and Serial Output. Input Range with 5V Supply: $0\text{V} \leq V_{IN} \leq 5\text{V}$.	12 Bits	± 0.5 LSB Linearity, ± 3 LSB Offset, and ± 1 LSB Full-Scale Error Over Full Temperature Range.	20ksps	5V	12mA, 10 μ A During Shutdown	J, N	12-Bit ADC with Built-In Sample-and-Hold. Compatible with All Microprocessors' Serial Ports. Automatic Power-Down.
LTC1298C,I	12-Bit, 8-Pin, Serial I/O, 340 μ A (Typ) Sampling A/D Converter with Automatic Power-Down.	12 Bits	± 2 LSB Linearity, ± 0.75 LSB Differential Nonlinearity, ± 3 LSB Offset, and ± 8 LSB Full-Scale Error Over Full Temperature Range.	11.1ksps	5V to 9V	640 μ A, 3 μ A During Shutdown	N, S	12-Bit ADC with Built-In Sample-and-Hold and 2-Channel MUX. Compatible with All Microprocessors' Serial Ports. Automatic Power-Down.

Application Note 62

Digital-to-Analog Converter Selection Guide

PART NUMBER	DESCRIPTION	RESOLUTION	TOTAL UNADJUSTED ERROR	SETTLING TIME	VOLTAGE SUPPLY	MAXIMUM SUPPLY CURRENT	PKGS. AVAIL.	IMPORTANT FEATURES
LTC1257C,I	12-Bit, Serial I/O, 8-Pin D/A Converter. Cascadable Serial I/O. Internal 2.048V Reference. Voltage Output.	12 Bits	±0.5LSB DNL, ±3.5LSB INL	6µs (±1/2LSB)	5V to 15.5V	600µA at V _{CC} = 5V	N, S	12-Bit DAC with Cascadable Serial I/O, Built-In Reference, and Voltage Output. Wide Supply Range of 5V to 15.5V. Space Saving SO-8 Package.

APPENDIX B

VOLTAGE REFERENCES

Listed by Temperature Drift (T.C.) and Initial Accuracy

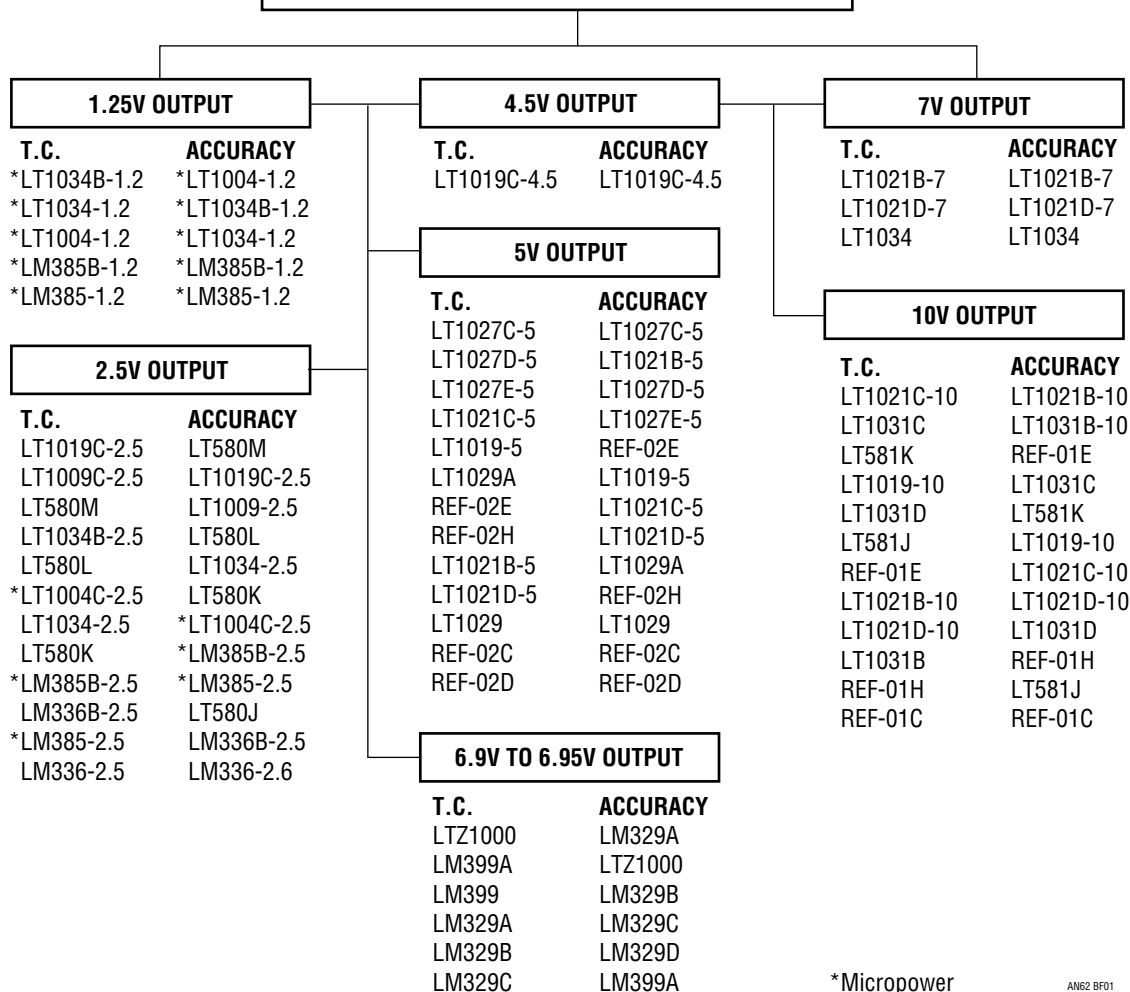

*Micropower

AN62 BF01