



Power Conversion from Milliamps to Amps at Ultra-High Efficiency (Up to 95%)

Dimitry Goder
Randy Flatness

INTRODUCTION

High efficiency is frequently the main goal for power supplies in portable computers and hand-held equipment. Efficient converters are necessary in these applications to minimize power drain on the input source (batteries, etc.) and heat buildup in the power components, allowing for smaller, lighter, and longer-lived systems. Power conversion efficiency must be in the 90% range in order to meet these goals. This application note features power supply circuits that satisfy these design requirements and attain high efficiency over a wide operating range.

The recent development of the LTC[®]1142, LTC1143, LTC1147, LTC1148, and LTC1149 makes ultra-high efficiency conversion possible. In addition, the LTC1148, LTC1149, and LTC1142 are synchronous switching regulators, achieving high efficiency conversion at output currents in excess of 10A. These controllers feature a

current mode architecture that has automatic Burst Mode[™] operation at low currents. This technology makes 90% efficiencies possible at output currents as low as 10mA, maximizing battery life while a product is in sleep or standby mode.

These ultra-high efficiency converters also implement constant off-time architecture, fully synchronous switching and low dropout regulation. All these features make this series of converters a really excellent choice for a vast variety of applications.

Achieving high efficiency is one of the primary goals of switching regulator design. Every application circuit shown in this note includes detailed efficiency graphs. Almost all of the magnetic parts used in the circuits are standard products, available off-the-shelf from various manufacturers.



Application Note 54

TABLE OF CONTENTS

Buck

LTC1148: (5V-14V to 5V/1A) Buck Converter with Surface Mount Technology	Figure 1	AN54-3
LTC1148: (5V-14V to 5V/2A) Buck Converter	Figure 2	AN54-4
LTC1148: (5V-14V to 5V/2A) High Frequency Buck Converter with Surface Mount Technology	Figure 3	AN54-5
LTC1148: (4V-14V to 3.3V/1A) Buck Converter with Surface Mount Technology	Figure 4	AN54-6
LTC1148: (4V-14V to 3.3V/2A) Buck Converter with Surface Mount Technology	Figure 5	AN54-7
LTC1148: (5V to 3.3V/5A) High Efficiency Step-Down Converter	Figure 6	AN54-8
LTC1148: (5V to 3.5V/3A) High Efficiency Step-Down Converter	Figure 7	AN54-9
LTC1149: (10V-48V to 5V/2A) High Voltage Buck Converter	Figure 8	AN54-10
LTC1149: (10V-48V to 5V/2A) High Voltage Buck Converter with Large P-Channel and N-Channel MOSFETs	Figure 9	AN54-11
LTC1149: (10V-48V to 3.3V/2A) High Voltage Buck Converter	Figure 10	AN54-12
LTC1149: (10V-48V to 12V/2A) High Voltage Buck Converter	Figure 11	AN54-13
LTC1149: (16V _{RMS} to 13.8/10A) Buck Converter	Figure 12	AN54-14
LTC1149: (32V _{RMS} to 27.6V/5A) Buck Converter	Figure 13	AN54-15
LTC1147: (5V-14V to 5V/1A) Buck Converter with Surface Mount Technology	Figure 14	AN54-16
LTC1147: (4V-14V to 3.3V/1A) Buck Converter with Surface Mount Technology	Figure 15	AN54-17
LTC1147: (4V-8V to 3.3V/1.5A) Buck Converter with Surface Mount Technology	Figure 16	AN54-18
LTC1148: (10V-14V to 5V/10A) High Current Buck Convert	Figure 17	AN54-19
LTC1149: (12V-36V to 5V/5A) High Current, High Voltage Buck Converter	Figure 18	AN54-20
LTC1149: (12V-48V to 5V/10A) High Current, High Voltage Buck Converter	Figure 19	AN54-21
LTC1149: (32V-48V to 24V/10A) High Current, High Voltage Buck Converter	Figure 20	AN54-22
LTC1143: (5.2V-14V to 3.3V/2A and 5V/2A) Dual Buck Converter	Figure 26	AN54-28
LTC1148HV-5: (5.2V-18V to 5V/1A) High Voltage Buck Converter	Figure 27	AN54-29
LTC1148HV-3.3 (4V-18V to 3.3V/1A) High Voltage Buck Converter	Figure 28	AN54-30
LTC1148HV: (12.5V-18V to 12V/2A) High Voltage Buck Converter	Figure 29	AN54-31
LTC1142: (6.5V-14V to 3.3V/2A, 5V/2A, 12V/0.15A) Triple Output Buck Converter	Figure 30	AN54-32
LTC1142HV: (6.5V-18V to 3.3V/2A, 5V/2A, 12V/0.15A) High Voltage Triple Output Buck Converter	Figure 31	AN54-34
Single LTC1149: Dual Output Buck Converter	Figure 35	AN54-38
LTC1148: (8V-15V to 5V/2A) Constant Frequency Buck Converter	Figure 36	AN54-39
LTC1148: (4.5V-6.5V to 3.3V/2A) Constant Frequency Buck Converter	Figure 37	AN54-40

Buck-Boost and Inverting Topologies

LTC1148: (4V-14V to 5V/1A) SEPIC Converter	Figure 21	AN54-23
LTC1148: (4V-14V to 5V/0.5A, -5V/0.5A) Split Supply Converter	Figure 22	AN54-24
LTC1148: (4V-10V to -5V/1A) Positive-to-Negative Converter	Figure 23	AN54-25
LTC1148: (5V-12V to -15V/0.5A) Buck-Boost Converter	Figure 24	AN54-26

Boost

LTC1148: (2V-5V to 5V/1A) Boost Converter	Figure 25	AN54-27
---	-----------	---------

Battery Charging Circuits

LTC1148: High Efficiency Charger Circuit	Figure 32	AN54-35
LTC1148: High Voltage Charger Circuit	Figure 33	AN54-36
LTC1142A: High Efficiency Power Supply Providing 3.3V/2A with Built-In Battery Charger	Figure 34	AN54-37

Appendix A

Topics of Common Interest		AN54-40
---------------------------------	--	---------

Appendix B

Suggested Manufacturers		AN54-42
-------------------------------	--	---------

LTC1148: (5V-14V to 5V/1A) Buck Converter with Surface Mount Technology

A basic LTC1148 application is shown in Figure 1A. This is a conventional step-down converter that provides 5V output at 1A maximum output current. All the components used are surface mounted and no heat sink is required. During Q1 on-time, inductor L1's current is sensed by R2 and monitored by an internal current sensing comparator. To filter out noise from the current sense waveform, C6 is added to the circuit. When the current ramp reaches a preset value, Q1 is turned off, and a clamp diode D1 starts conducting for a short period of time, until the internal control logic senses that Q1 is completely off. Then N_{DRIVE} output goes high turning Q2 on, which shorts out D1. This provides synchronous rectification and significantly reduces conduction losses during Q1's off-time.

This regulator has a constant off-time defined by the timing capacitor C5. To control the output, on-time is varied,

changing the operating frequency and therefore, the duty cycle. If the input voltage is reduced, frequency decreases keeping output voltage at the same level. Q1's on-time stretches to infinity with low input voltage, providing 100% duty cycle and very low dropout. Under dropout conditions, the output voltage follows the input, less any resistive losses in Q1, L1 and R2.

Under conditions of light output currents, the regulator enters Burst Mode operation to ensure high efficiency. Continuous operation is interrupted by an internal voltage sensing comparator with built-in hysteresis. In this mode both Q1 and Q2 are turned off and the comparator monitors decreasing output voltage. When the output capacitor discharges below a fixed threshold, operation resumes for a short period of time bringing the output voltage back to normal. Then the regulator shuts down again conserving quiescent current. Under Burst Mode operation the output ripple is typically 50mV as set by the hysteresis in the comparator.

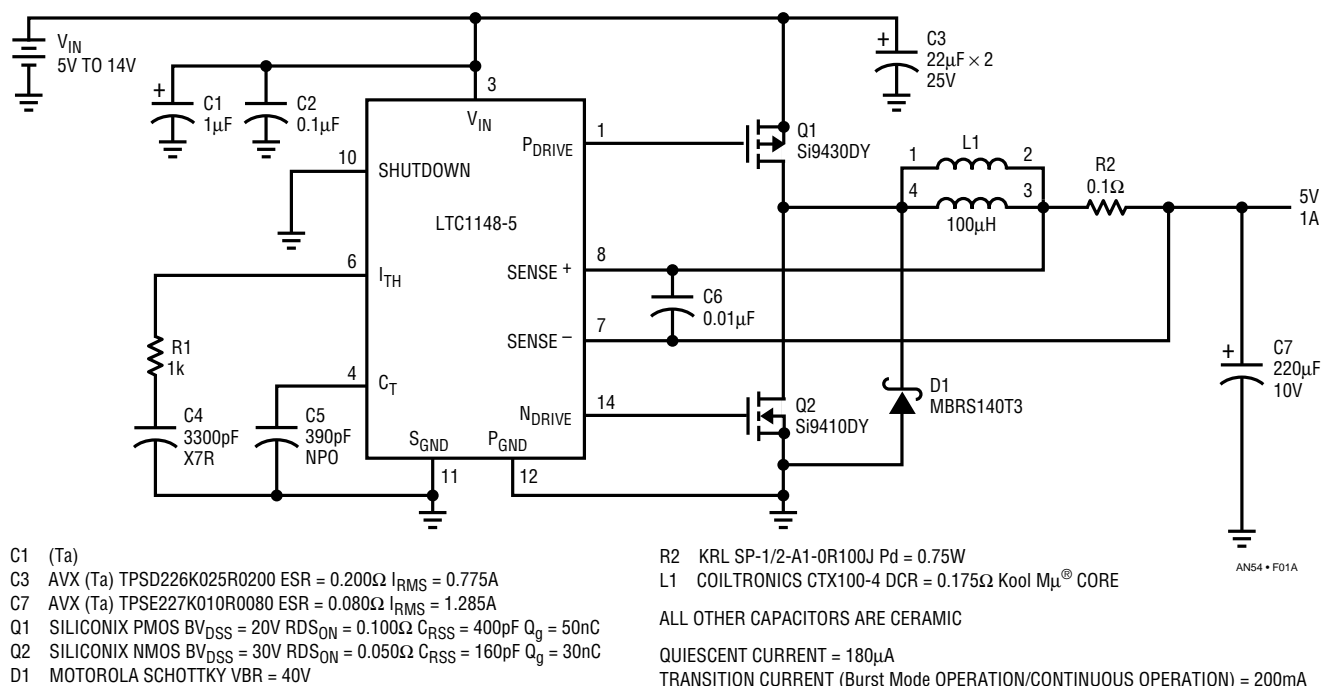
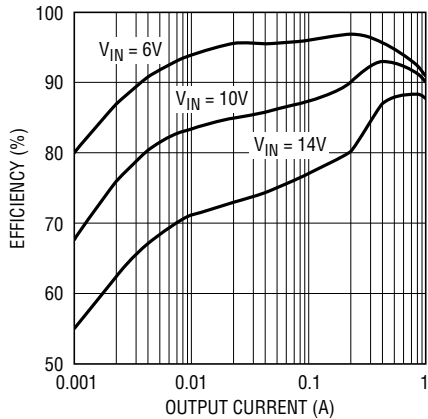

Figure 1A. LTC1148: (5V-14V to 5V/1A) Buck Converter with Surface Mount Technology

Application Note 54

Figure 1B shows efficiency versus output current for three different input voltages. Generally speaking, efficiency drops as a function of input voltage due to gate charge losses and LTC1148 DC bias current. The curves converge at maximum output current as these losses become less significant.



ANS4 • F01B

Figure 1B. LTC1148: (5V-14V to 5V/1A) Buck Converter Measured Efficiency

LTC1148: (5V-14V to 5V/2A) Buck Converter

A step-down regulator with 2A output current capability is shown in Figure 2A. To provide higher output power levels the sense resistor value is decreased, thus increasing the current limit. This also increases maximum allowable ripple current in the inductor, so its value can be reduced. Note that timing capacitor C5 is changed to optimize performance for a standard inductor value. In this Figure C7 consists of two parallel capacitors ensuring minimum capacitance requirement for all conditions. A circuit board has been laid out for this circuit and has subsequently been thoroughly tested under full operating conditions and optimized for mass production requirements. A Gerber file for the board is available upon request.

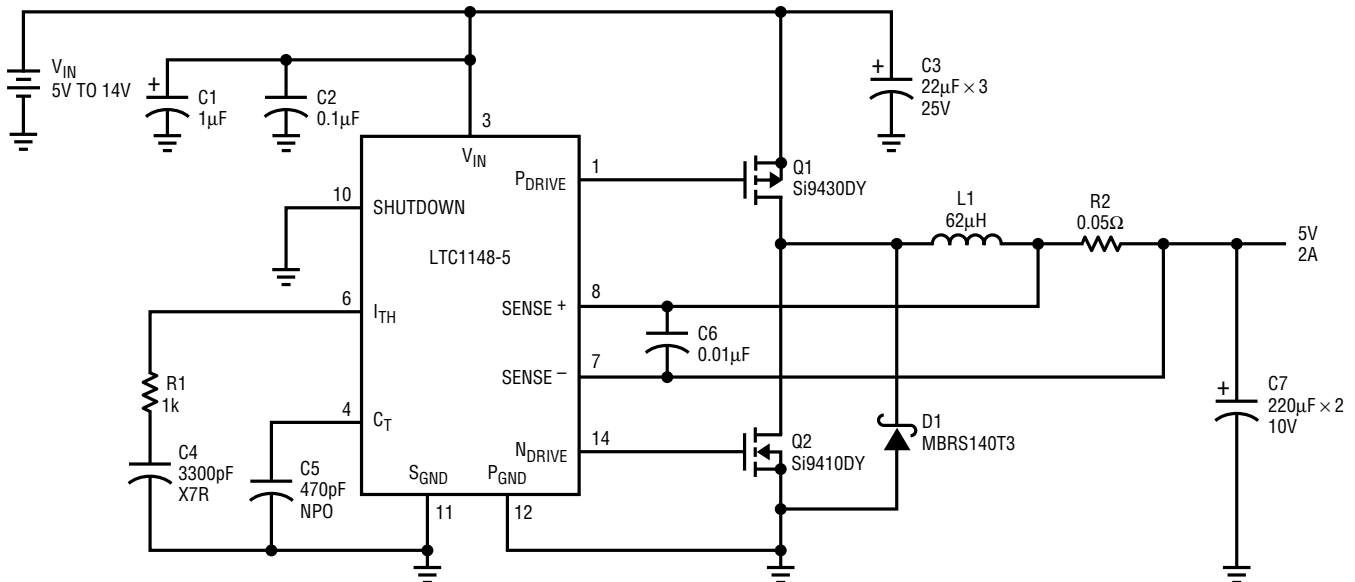

- C1 (Ta)
- C3 AVX (Ta) TPSD226K025R0200 ESR = 0.200Ω I_{RMS} = 0.775A
- C7 AVX (Ta) TPSE227K010R0080 ESR = 0.080Ω I_{RMS} = 1.285A
- Q1 SILICONIX PMOS BV_{DSS} = 20V RDS_{ON} = 0.100Ω C_{RSS} = 400pF Q_g = 50nC
- Q2 SILICONIX NMOS BV_{DSS} = 30V RDS_{ON} = 0.050Ω C_{RSS} = 160pF Q_g = 30nC
- D1 MOTOROLA SCHOTTKY VBR = 40V
- R2 KRL SL-1-C1-0R050J Pd = 1W
- L1 COILTRONICS CTX62-2-MP DCR = 0.040Ω MPP CORE (THROUGH HOLE)

QUIESCENT CURRENT = 180µA
 TRANSITION CURRENT (Burst Mode OPERATION/CONTINUOUS OPERATION) = 400mA

ALL OTHER CAPACITORS ARE CERAMIC

ANS4 • F02A

Figure 2A. LTC1148: (5V-14V to 5V/2A) Buck Converter

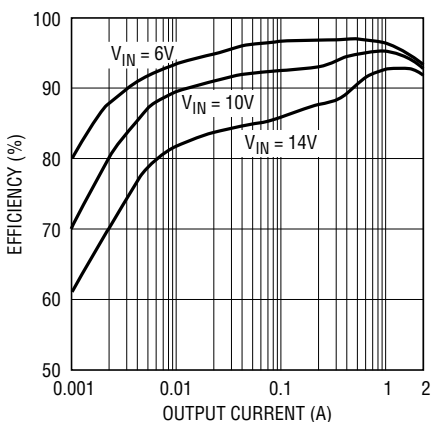

ANS4 • F02B

Figure 2B. LTC1148: (5V-14V to 5V/2A) Buck Converter Measured Efficiency

LTC1148: (5V-14V to 5V/2A) High Frequency Buck Converter with Surface Mount Technology

Figure 3A presents essentially the same circuit as Figure 2A, but implementing changes to operate at a higher frequency. Timing capacitor C5 is reduced to achieve higher switching rate. This approach allows the use of a smaller value inductor with surface mount technology, resulting in a more compact design.

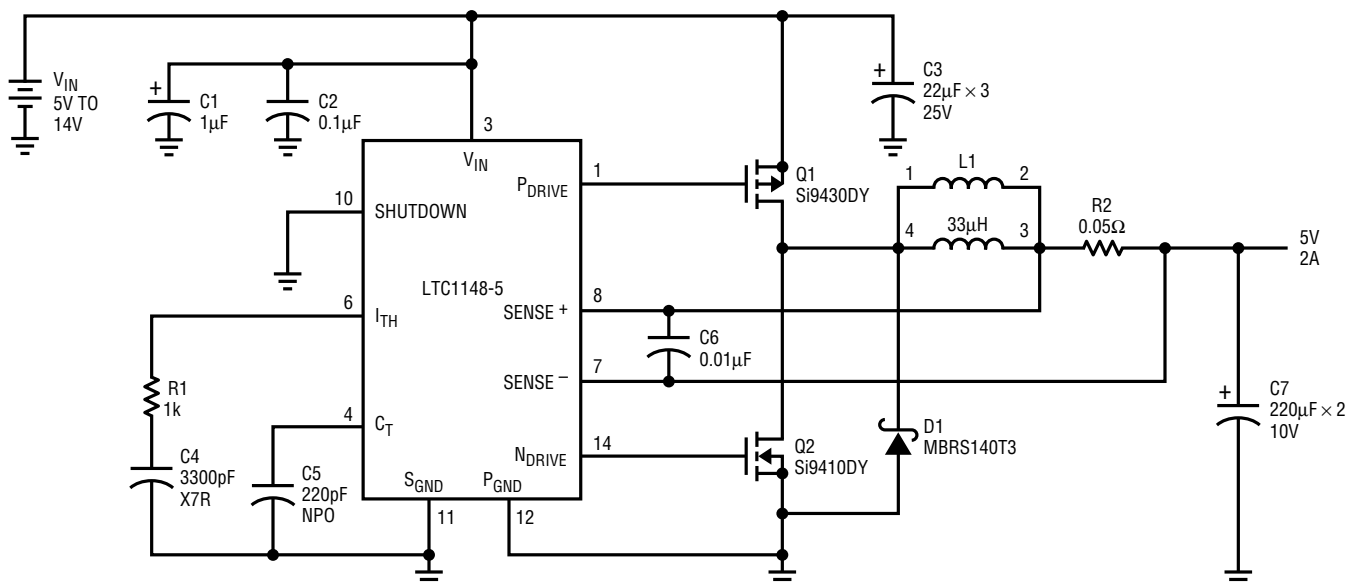

- C1 (Ta)
- C3 AVX (Ta) TPSD226K025R0200 ESR = 0.200Ω I_{RMS} = 0.775A
- C7 AVX (Ta) TPSE227K010R0080 ESR = 0.080Ω I_{RMS} = 1.285A
- Q1 SILICONIX PMOS BV_{DSS} = 20V RDS_{ON} = 0.100Ω C_{RSS} = 400pF Q_g = 50nC
- Q2 SILICONIX NMOS BV_{DSS} = 30V RDS_{ON} = 0.050Ω C_{RSS} = 160pF Q_g = 30nC
- D1 MOTOROLA SCHOTTKY VBR = 40V
- R2 KRL SL-1-C1-0R050J Pd = 1W
- L1 COILTRONICS CTX33-4 DCR = 0.06Ω Kool Mµ CORE

ALL OTHER CAPACITORS ARE CERAMIC

QUIESCENT CURRENT = 180µA
 TRANSITION CURRENT (Burst Mode OPERATION/CONTINUOUS OPERATION) = 400mA

ANS4 • F03A

Figure 3A. LTC1148: (5V-14V to 5V/2A) High Frequency Buck Converter with Surface Mount Technology

Application Note 54

Let us compare efficiency graphs in Figures 2B and 3B. Gate charge losses are directly proportional to operating frequency, and as a result the efficiency of Figure 3A is

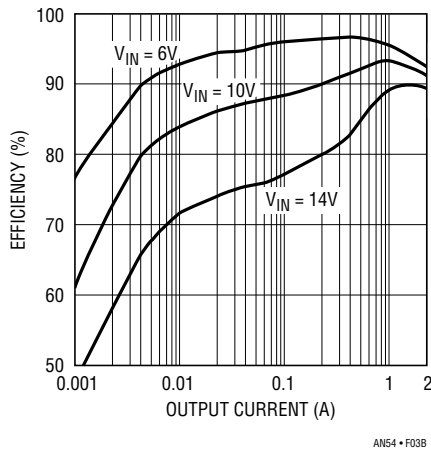
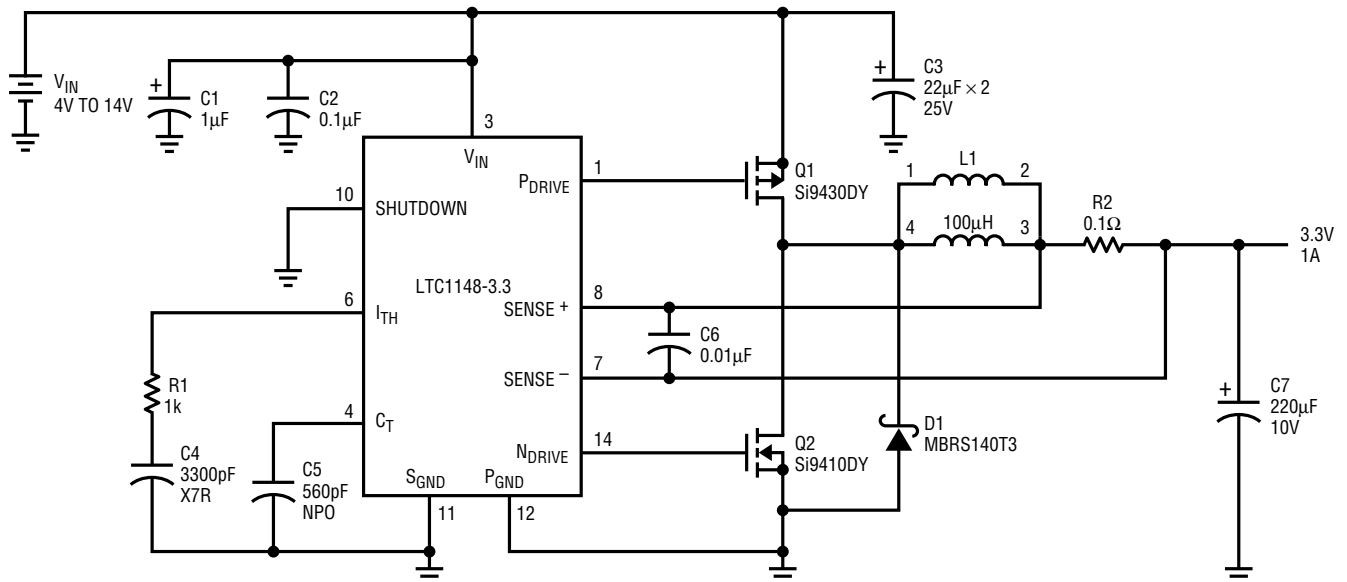

Figure 3B. LTC1148: (5V-14V to 5V/2A) High Frequency Buck Converter Measured Efficiency

decreased. However, the effect is most noticeable at high input voltages and low currents. At maximum load I^2R losses dominate so that the regulator performance varies only slightly. These two circuits illustrate the fact that best overall efficiency is reached at moderate frequencies. They represent a nice example of compromising between regulator compactness and efficiency.

LTC1148: (4V-14V to 3.3V) Buck Converters with Surface Mount Technology

Figures 4A and 5A show application circuits for the LTC1148-3.3 which provides a fixed 3.3V output. The circuits deliver 1A and 2A output currents, and use exactly the same circuit configuration and component values as Figures 1A and 2A. Even though the LTC1148 can achieve low dropout, the minimum input voltage is limited to 4V to meet requirements for power MOSFET gate drive, and to ensure proper operation of the LTC1148 internal circuitry.



- C1 (Ta)
- C3 AVX (Ta) TPSD226K025R0200 ESR = 0.200Ω I_{RMS} = 0.775A
- C7 AVX (Ta) TPSE227K010R0080 ESR = 0.080Ω I_{RMS} = 1.285A
- Q1 SILICONIX PMOS BV_{DSS} = 20V RDS_{ON} = 0.100Ω C_{RSS} = 400pF Q_g = 50nC
- Q2 SILICONIX NMOS BV_{DSS} = 30V RDS_{ON} = 0.050Ω C_{RSS} = 160pF Q_g = 30nC
- D1 MOTOROLA SCHOTTKY VBR = 40V
- R2 KRL SP-1/2-A1-0R100J Pd = 0.75W
- L1 COILTRONICS CTX100-4 DCR = 0.175Ω Kool Mµ CORE

QUIESCENT CURRENT = 180µA
 TRANSITION CURRENT (Burst Mode OPERATION/CONTINUOUS OPERATION) = 250mA

ALL OTHER CAPACITORS ARE CERAMIC

ANS4 • F04A

Figure 4A. LTC1148: (4V-14V to 3.3V/1A) Buck Converter with Surface Mount Technology

Application Note 54

Low output voltage causes efficiency degradation at light loads when the chip's DC supply current and gate charge current play major parts in total losses. Figures 4B and

5B illustrate this point as the efficiency falls off below 10mA output current. High input voltage compounds the problem.

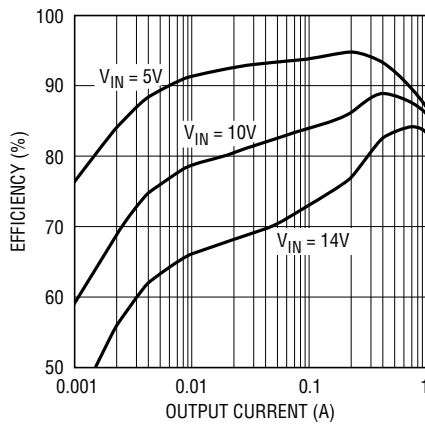

ANS4 • F04B

Figure 4B. LTC1148: (4V-14V to 3.3V/1A) Buck Converter Measured Efficiency

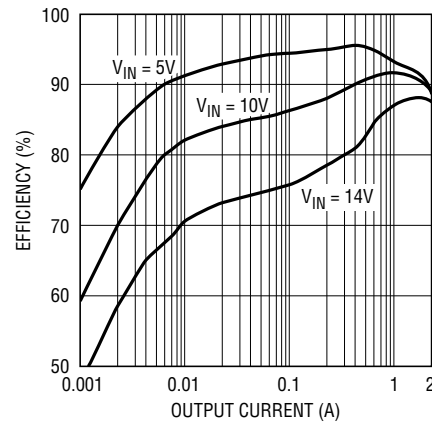

ANS4 • F05B

Figure 5B. LTC1148: (4V-14V to 3.3V/2A) Buck Converter Measured Efficiency

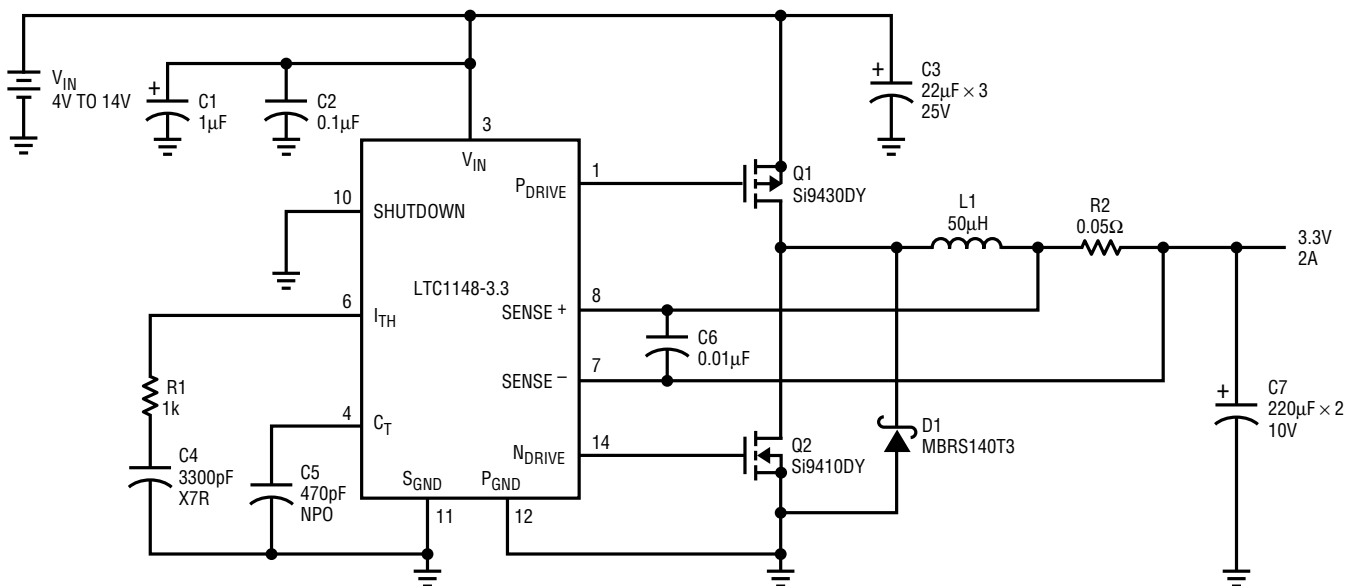

- C1 (Ta)
- C3 AVX (Ta) TPSD226K025R0200 ESR = 0.200Ω I_{RMS} = 0.775A
- C7 AVX (Ta) TPSE227K010R0080 ESR = 0.080Ω I_{RMS} = 1.285A
- Q1 SILICONIX PMOS BV_{DSS} = 20V RDS_{ON} = 0.100Ω CRSS = 400pF Qg = 50nC
- Q2 SILICONIX NMOS BV_{DSS} = 30V RDS_{ON} = 0.050Ω CRSS = 160pF Qg = 30nC
- D1 MOTOROLA SCHOTTKY VBR = 40V
- R2 KRL SL-1-C1-0R050J Pd = 1W
- L1 COILTRONICS CTX50-2-MP DCR = 0.032Ω MPP CORE (THROUGH HOLE)

QUIESCENT CURRENT = 180µA
 TRANSITION CURRENT (Burst Mode OPERATION/CONTINUOUS OPERATION) = 450mA

ALL OTHER CAPACITORS ARE CERAMIC

ANS4 • F05A

Figure 5A. LTC1148: (4V-14V to 3.3V/2A) Buck Converter with Surface Mount Technology

Application Note 54

LTC1148: (5V to 3.3V/5A) High Efficiency Step-Down Converter

Many new microprocessor designs require 3.3V, yet they are used in systems where 5V is the primary source of power. A high efficiency 5V to 3.3V converter is drawn in Figure 6A. It supplies up to 5A load using only surface mount components. Two P-channel MOSFETs are connected in parallel to decrease their conduction losses. Efficiency at 5V input is 90%; this means only 1.6W is lost. The lost power is distributed between R_{SENSE} , L1 and the power MOSFETs, thus no heat sinking is required.

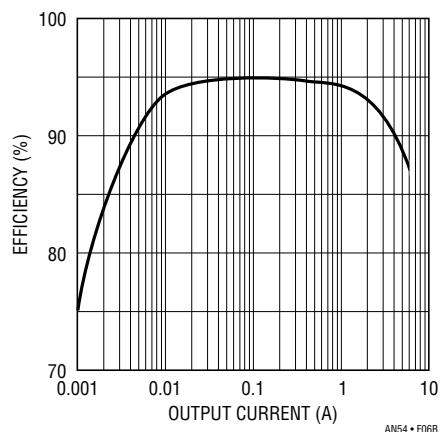

Figure 6B. LTC1148: (5V to 3.3V/5A) Buck Converter Measured Efficiency

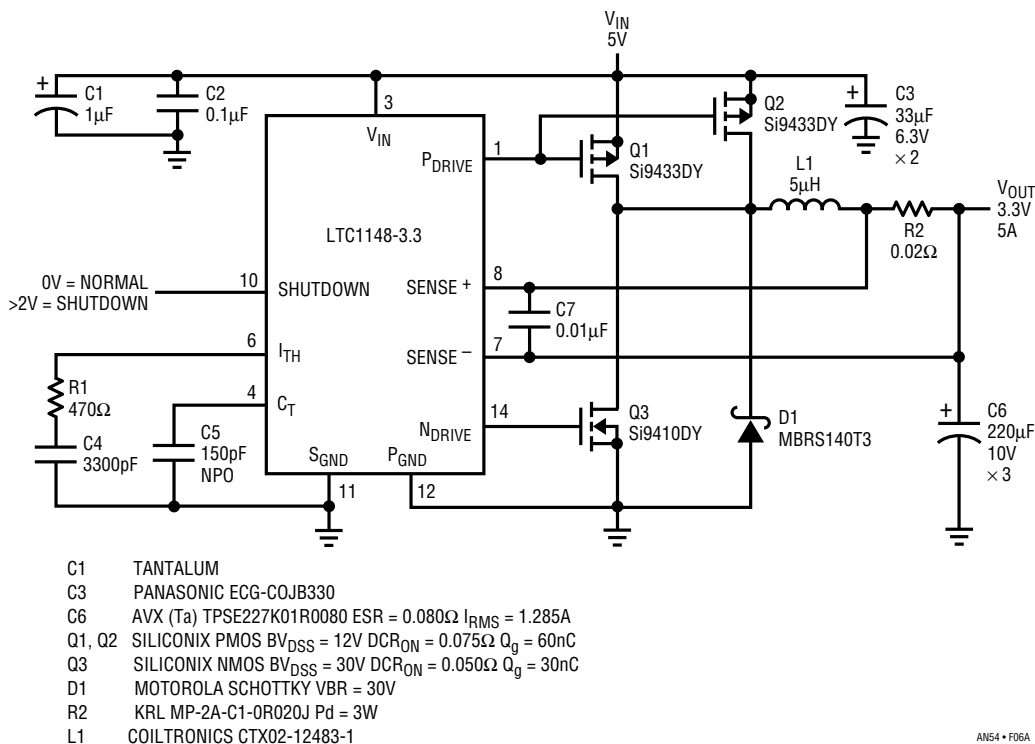
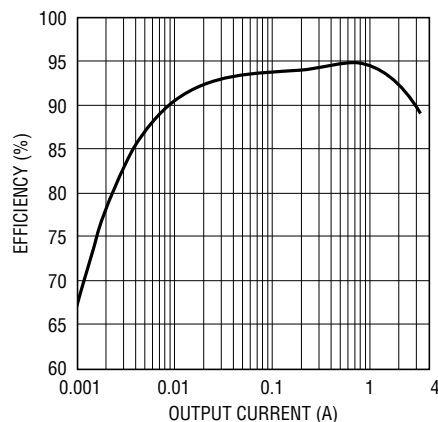

Figure 6A. LTC1148: (5V to 3.3V/5A) High Efficiency Step-Down Converter

LTC1148: (5V to 3.5V/3A) High Efficiency Step-Down Converter

Some processors require 3.5V or other intermediate voltage derived from a 5V supply. A good solution for them is the circuit in Figure 7A. An adjustable version of the LTC1148 allows precise output voltage adjustment, while preserving efficiencies of 95%. The output voltage is set by resistors R3 and R4.



ANS4 • F07B

Figure 7B. LTC1148: (5V to 3.5V/3A) Measured Efficiency

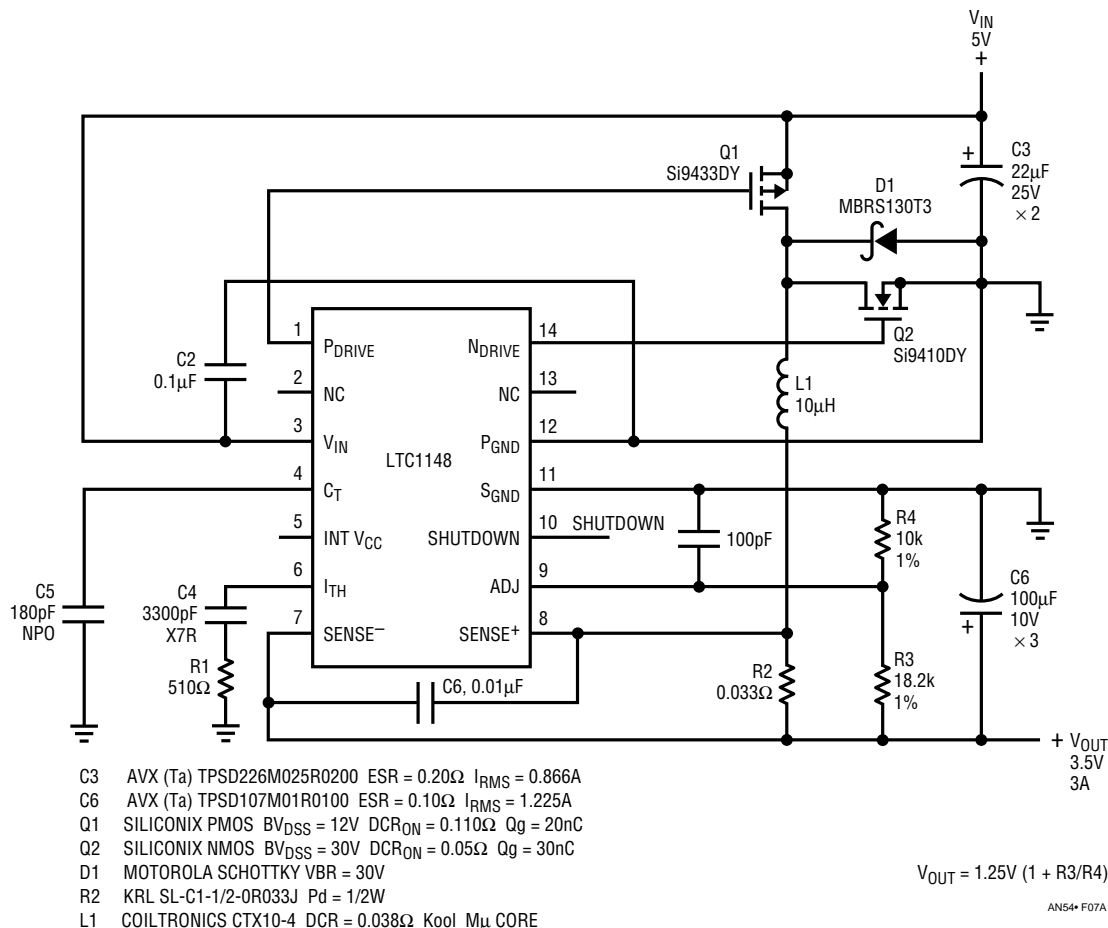

Figure 7A. LTC1148: (5V to 3.5V/3A) High Efficiency Step-Down Converter

Application Note 54

LTC1149: (10V-48V to 5V/2A) High Voltage Buck Converter

Previous circuits can accept inputs up to 14V. If higher input voltage is required the LTC1149 can be used. This IC is designed for inputs of up to 48V. A basic step-down application circuit is shown in Figure 8A. It operates in the same fashion as the circuit in Figure 1A and provides 5V/2A output. However, different MOSFETs are used since they must withstand 48V between source and drain. High current efficiency exceeds 92% over wide range of input voltages. Since the control and drive circuitry are powered directly from the input line, DC bias current and gate charge current result in slightly lower efficiency at light and moderate loads due to high input voltage (relative to LTC1148). This characteristic is eliminated in the circuit of Figure 11A. A circuit board has been laid out for this circuit and has subsequently been thoroughly tested under full

operating conditions and optimized for mass production requirements. A Gerber file for the board is available upon request.

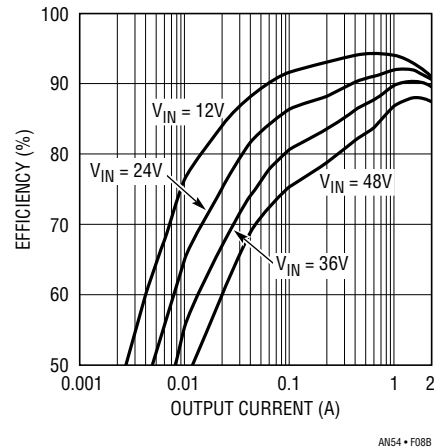
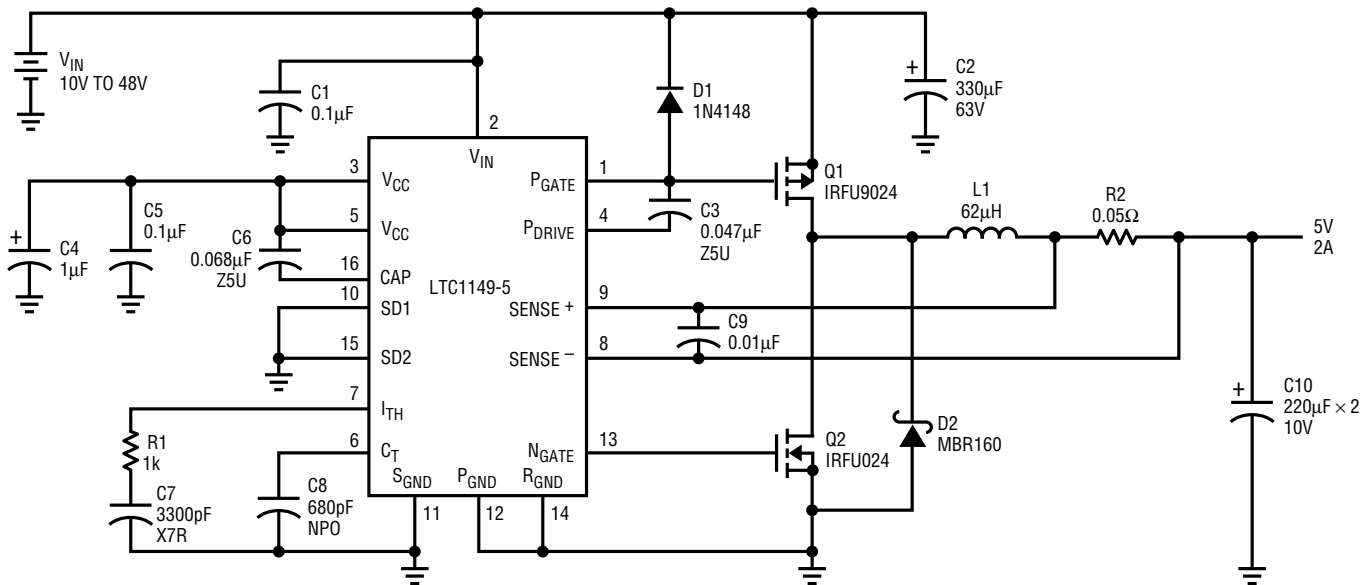

Figure 8B. LTC1149: (10V-48V to 5V/2A) High Voltage Buck Converter Measured Efficiency



- C2 UNITED CHEMI-CON (AI) LXF63VB331M12.5 x 30 ESR = 0.170Ω I_{RMS} = 1.280A
- C4 (Ta)
- C10 SANYO (OS-CON) 10SA220M ESR = 0.035Ω I_{RMS} = 2.360A
- Q1 IR PMOS BV_{DSS} = 60V RDS_{ON} = 0.280Ω CRSS = 65pF Q_g = 19nC
- Q2 IR NMOS BV_{DSS} = 60V RDS_{ON} = 0.100Ω CRSS = 79pF Q_g = 28nC
- D1 SILICON VBR = 75V
- D2 MOTOROLA SCHOTTKY VBR = 60V
- R2 KRL NP-1A-C1-0R050J Pd = 1W
- L1 COILTRONICS CTX62-2-MP DCR = 0.040Ω MPP CORE

QUIESCENT CURRENT = 1.5mA
 TRANSITION CURRENT (Burst Mode OPERATION/CONTINUOUS OPERATION) = 570mA

ALL OTHER CAPACITORS ARE CERAMIC

AN54 • FOBA

Figure 8A. LTC1149: (10V-48V to 5V/2A) High Voltage Buck Converter

LTC1149: (10V-48V to 5V/2A) High Voltage Buck Converter with Large P-Channel and N-Channel MOSFETs

Figure 9A is similar to Figure 8A with much larger MOSFETs (TO220 package). These transistors have lower $R_{DS(ON)}$ which reduces their I^2R losses by roughly a factor of 2. However, the efficiency improves (compared to Figure 8B) only at 2A output current with minimum input voltage. Under other conditions higher gate capacitance causes increased gate charge current leading to higher driver loss. Also for high input voltages (roughly greater than 24V), transition losses play a significant part. These losses are proportional to the reverse transfer capacitance C_{RSS} , maximum output current, and the square of input voltage. Larger C_{RSS} for the oversized P-channel MOSFET causes an efficiency drop (especially for higher input voltages).

Remember, the “best” MOSFET selection depends on the particular application.

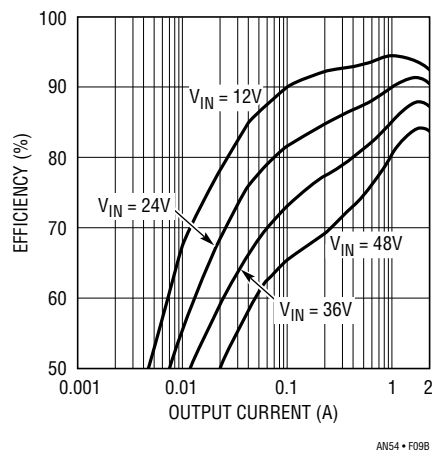
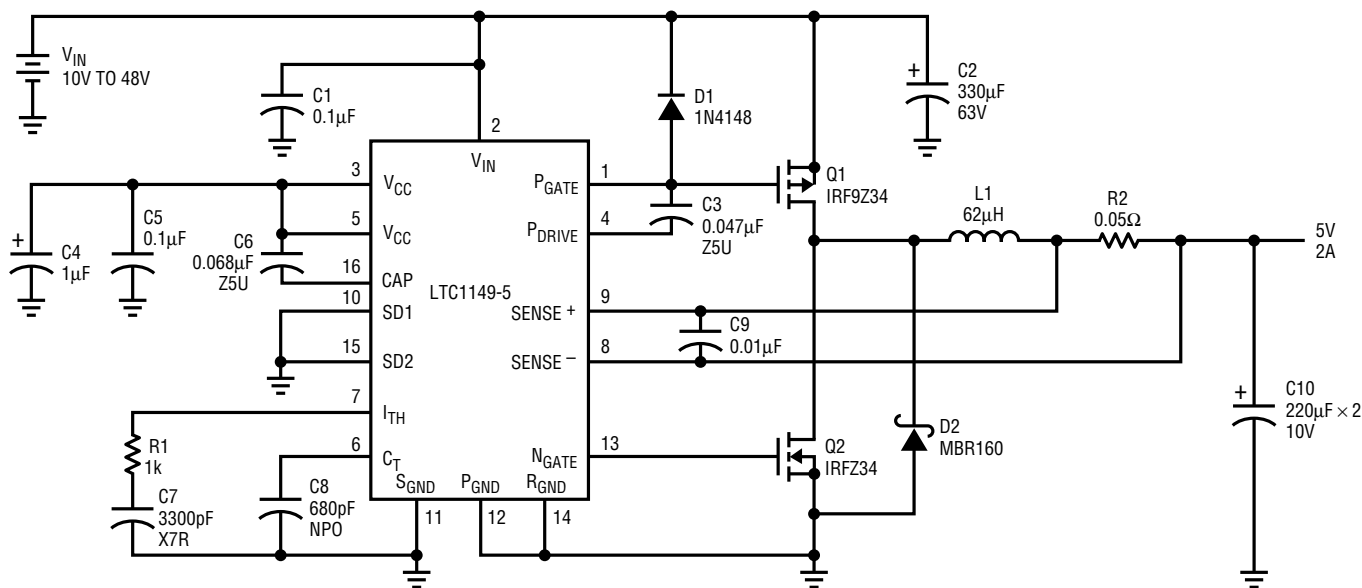

Figure 9B. LTC1149: (10V-48V to 5V/2A) Measured Efficiency with Large P-Channel and N-Channel MOSFETs



- C2 UNITED CHEMI-CON (AI) LXF63VB331M12.5 x 30 ESR = 0.170Ω I_{RMS} = 1.280A
- C4 (Ta)
- C10 SANYO (OS-CON) 10SA220M ESR = 0.035Ω I_{RMS} = 2.360A
- Q1 IR PMOS BV_{DSS} = 60V RDS_{ON} = 0.140Ω C_{RSS} = 100pF Q_g = 34nC
- Q2 IR NMOS BV_{DSS} = 60V RDS_{ON} = 0.050Ω C_{RSS} = 100pF Q_g = 32nC
- D1 SILICON VBR = 75V
- D2 MOTOROLA SCHOTTKY VBR = 60V
- R2 KRL NP-1A-C1-0R050J Pd = 1W
- L1 COILTRONICS CTX62-2-MP DCR = 0.040Ω MPP CORE

QUIESCENT CURRENT = 1.5mA
 TRANSITION CURRENT (Burst Mode OPERATION/CONTINUOUS OPERATION) = 560mA

ALL OTHER CAPACITORS ARE CERAMIC

ANS4 • F09A

Figure 9A. LTC1149: (10V-48V to 5V/2A) High Voltage Buck Converter with Large P-Channel and N-Channel MOSFETs

Application Note 54

LTC1149: (10V-48V to 3.3V/2A) High Voltage Buck Converter

If 3.3V has to be generated efficiently from a high voltage input, use the circuit of Figure 10A. It copies the configuration presented in Figure 8A but uses the LTC1149-3.3 regulator to provide a precise 3.3V output. In spite of the high input and low output voltages, efficiency still reaches 92%.

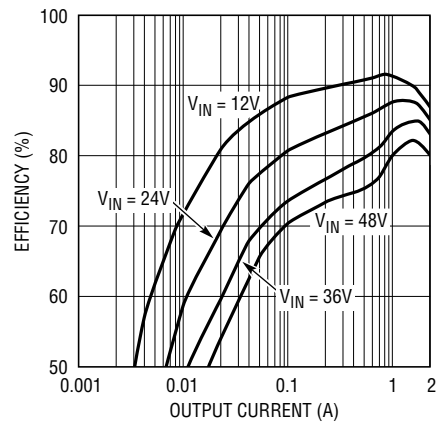
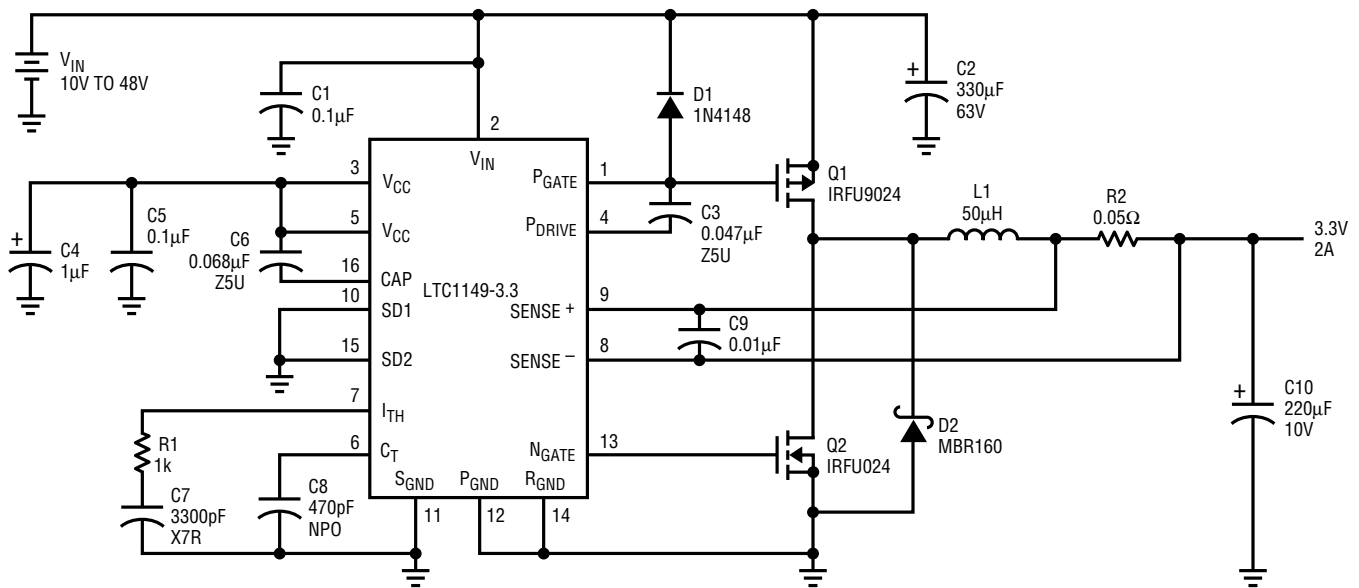

Figure 10B. LTC1149: (10V-48V to 3.3V/2A) High Voltage Buck Converter Measured Efficiency



- C2 UNITED CHEMI-CON (AI) LXF63VB331M12.5 × 30 ESR = 0.170Ω I_{RMS} = 1.280A
 - C4 (Ta)
 - C10 SANYO (OS-CON) 10SA220M ESR = 0.035Ω I_{RMS} = 2.360A
 - Q1 IR PMOS BV_{DSS} = 60V RDS_{ON} = 0.280Ω C_{RSS} = 65pF Q_g = 19nC
 - Q2 IR NMOS BV_{DSS} = 60V RDS_{ON} = 0.100Ω C_{RSS} = 79pF Q_g = 28nC
 - D1 SILICON VBR = 75V
 - D2 MOTOROLA SCHOTTKY VBR = 60V
 - R2 KRL NP-1A-C1-0R050J Pd = 1W
 - L1 COILTRONICS CTX50-2-MP DCR = 0.032Ω MPP CORE
- ALL OTHER CAPACITORS ARE CERAMIC

QUIESCENT CURRENT = 1.5mA
 TRANSITION CURRENT (Burst Mode OPERATION/CONTINUOUS OPERATION) = 570mA

ANS4 • F10A

Figure 10A. LTC1149: (10V-48V to 3.3V/2A) High Voltage Buck Converter

LTC1149: (10V-48V to 12V/2A) High Voltage Buck Converter

The LTC1149 contains an internal 10V low dropout linear regulator to provide power to the control circuitry. It actually means that the DC bias current as well as the gate charge current come directly from the input line, causing slight efficiency degradation, especially for high input voltages (additional power is dissipated by the internal regulator). A solution for this problem is presented in Figure 11A. When the output level reaches about 5V, Zener D3 starts conducting and saturates Q3, which in turn switches Q4 on. Now V_{CC} pins 3 and 5 are powered directly from the output. Losses caused by DC current and gate charge current are significantly reduced allowing improved efficiency at high input voltage.

The regulator output must be set up for an output voltage less than 14.5V to provide a margin for the LTC1149 pin 5 absolute maximum rating of 16V. It should also be

observed that Q4 turns on when the output is less than 10V (the internal regulator output) and stays on or off under all conditions.

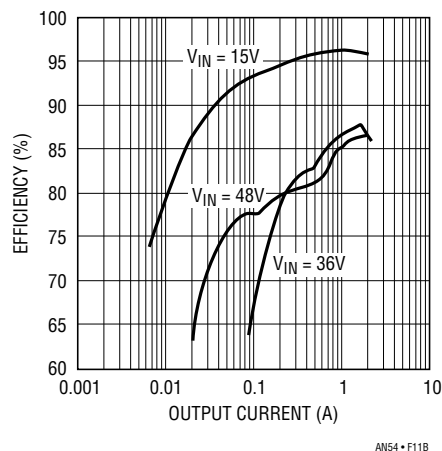
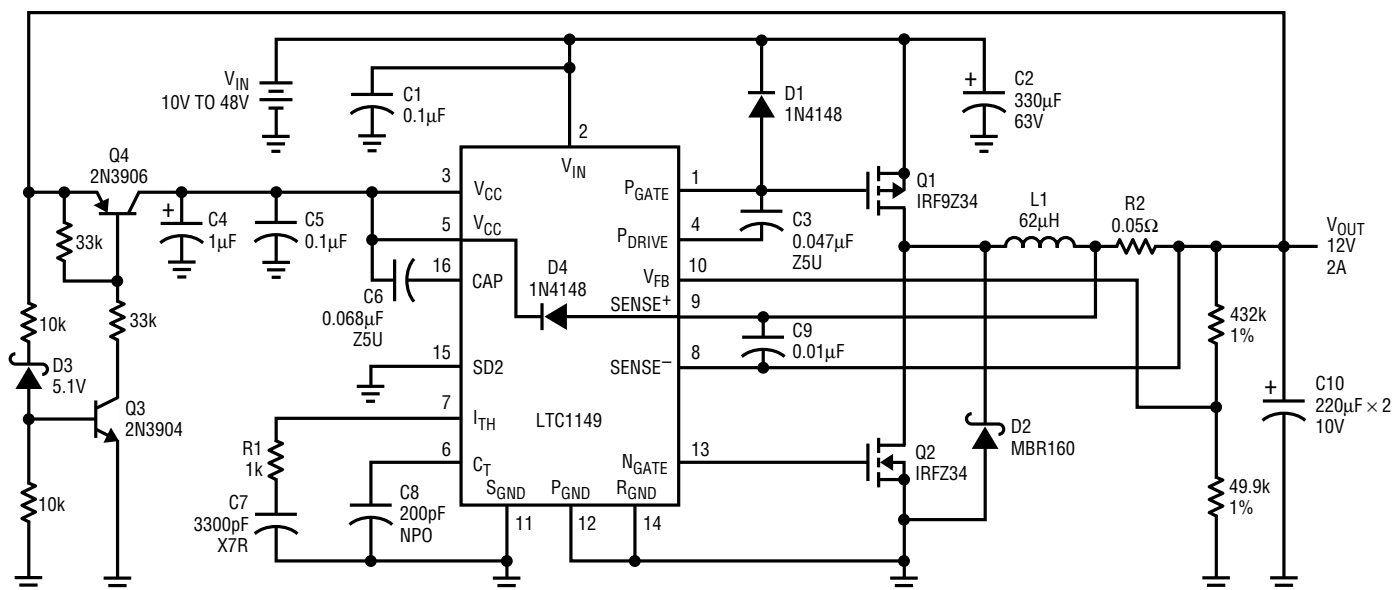

Figure 11B. LTC1149: (10V-48V to 5V/2A) Measured Efficiency with Large P-Channel and N-Channel MOSFETs



- C2 UNITED CHEMI-CON (AI) LXF63VB331M12.5 × 30 ESR = 0.170Ω $I_{RMS} = 1.280A$
 - C4 (Ta)
 - C10 SANYO (OS-CON) 10SA220M ESR = 0.035Ω $I_{RMS} = 2.360A$
 - Q1 IR PMOS $BV_{DSS} = 60V$ $R_{DS(ON)} = 0.140\Omega$ $C_{RSS} = 100pF$ $Q_g = 34nC$
 - Q2 IR NMOS $BV_{DSS} = 60V$ $R_{DS(ON)} = 0.050\Omega$ $C_{RSS} = 100pF$ $Q_g = 32nC$
 - D1 SILICON VBR = 75V
 - D2 MOTOROLA SCHOTTKY VBR = 60V
 - R2 KRL NP-1A-C1-0R050J Pd = 1W
 - L1 COILTRONICS CTX62-2-MP DCR = 0.040Ω MPP CORE
- ALL OTHER CAPACITORS ARE CERAMIC

QUIESCENT CURRENT = 1.5mA
 TRANSITION CURRENT (Burst Mode OPERATION/CONTINUOUS OPERATION) = 560mA

Figure 11A. LTC1149: (10V-48V to 12V/2A) High Voltage Buck Converter

Application Note 54

LTC1149: High Power Buck Converters

Figures 12A and 13A are examples of high power (more than 100W) converters that use the LTC1149. The regulators are powered from the full wave rectified output of a 16V_{RMS} to 32V_{RMS} transformer. Input capacitance is very bulky, but it has to ensure that ripple valleys do not dip below the minimum regulator input requirement. The circuit in Figure 13A has additional gate driver circuits which are required to improve MOSFET switching times. Overall efficiency goes as high as 98%! Remember, at these output current levels layout becomes extremely important, and all the recommendations from the LTC1149 data sheet must be closely followed.

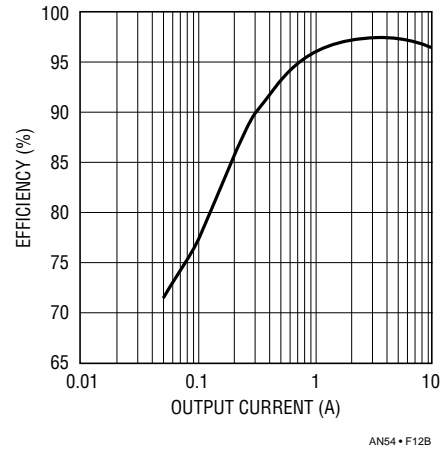

Figure 12B. LTC1149: (16V_{RMS} to 13.8V/10A) Buck Converter Measured Efficiency

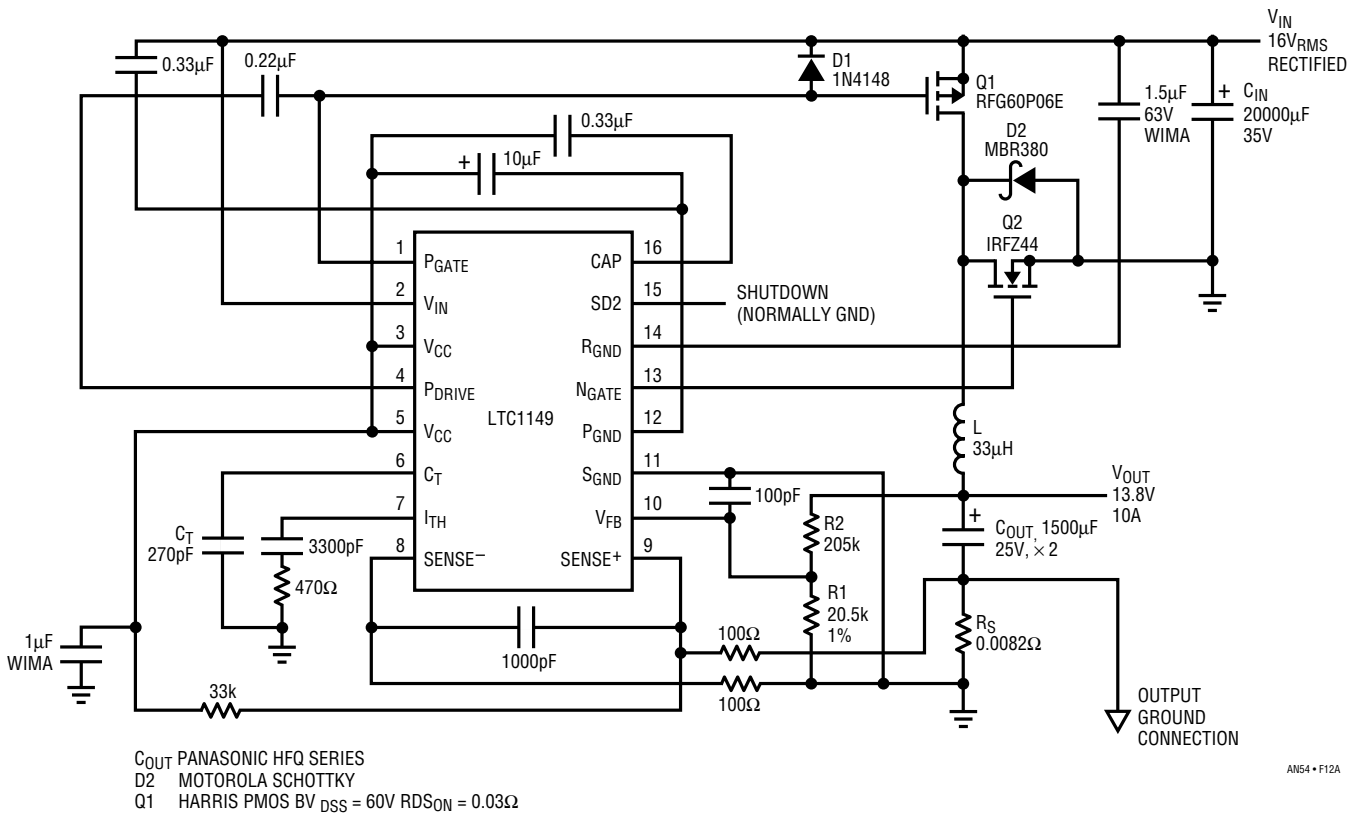
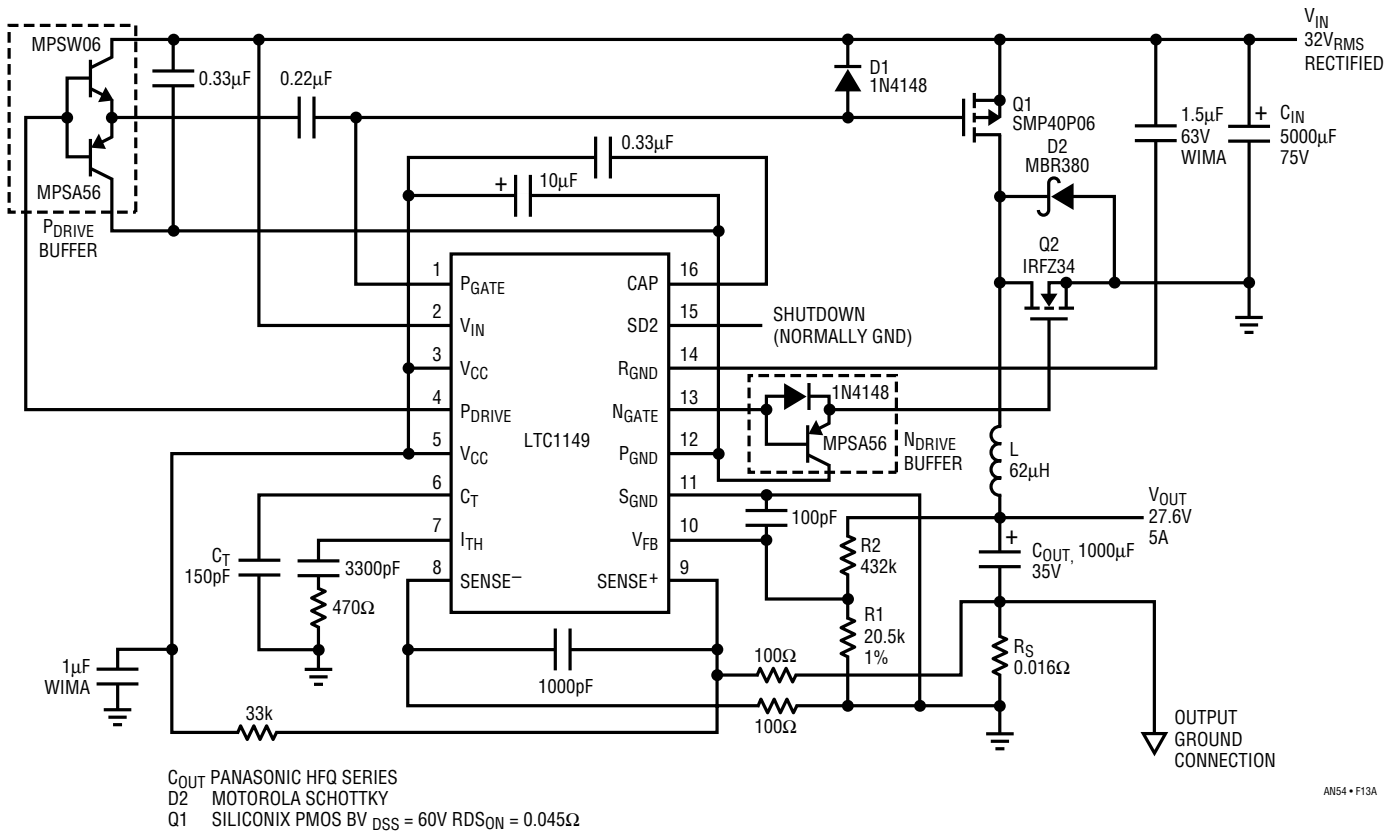
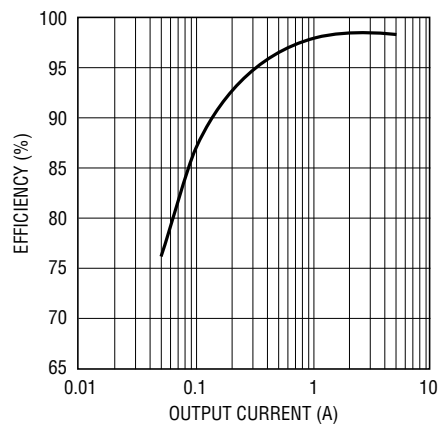

Figure 12A. LTC1149: (16V_{RMS} to 13.8V/10A) Buck Converter



AN54 • F13A

Figure 13A. LTC1149: (32V_{RMS} to 27.6V/5A) Buck Converter



AN54 • F13B

Figure 13B. LTC1149: (32V_{RMS} to 27.6V/5A) Buck Converter Measured Efficiency

Application Note 54

LTC1147: (5V-14V to 5V/1A) Buck Converter with Surface Mount Technology

The LTC1147 (Figure 14A) is a great way to implement a high efficiency regulator using a minimum number of external components and occupying the least board space. This regulator provides many advantages of the LTC1148 including constant off-time configuration, low dropout regulation and Burst Mode operation, comes in a smaller package and does not require the N-channel MOSFET. The only sacrifice made is synchronous rectification which degrades the efficiency of this circuit up to three percentage points. Compare efficiency graphs in Figures 1B and 14B! Since the clamp diode D1 conducts all the time during the off-time, a larger diode (MBRD330) is used for this circuit. The LTC1147 is an excellent choice where the output current is less than 1A, and where the input voltage is less than twice the output voltage.

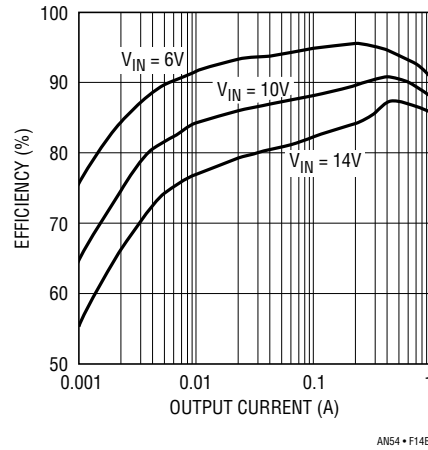
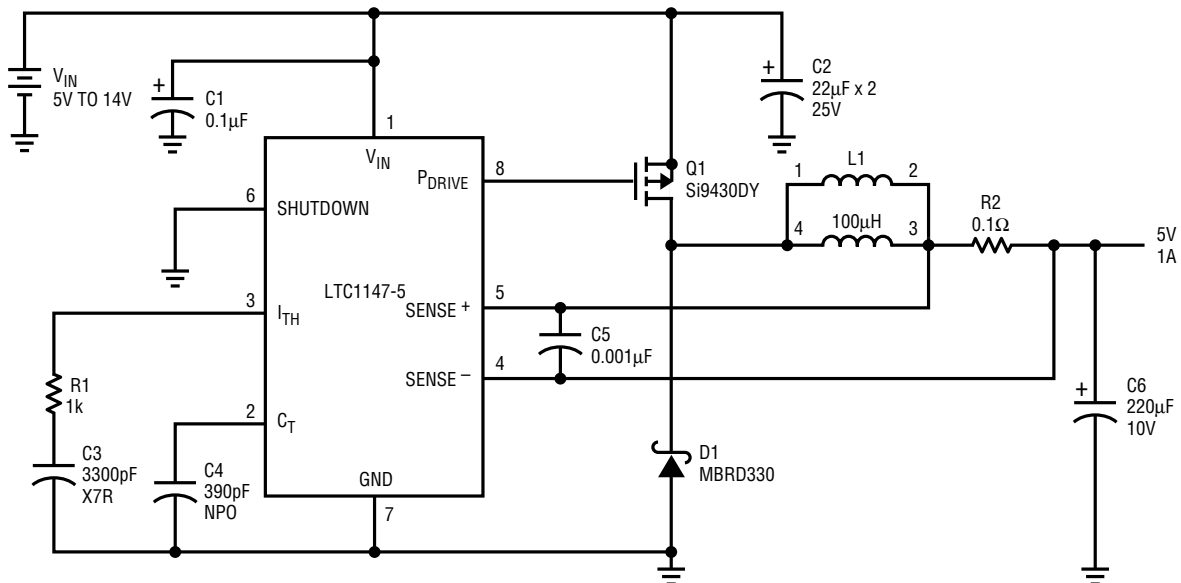

Figure 14B. LTC1147: (5V-14V to 5V/1A) Buck Converter Measured Efficiency



- C2 AVX (Ta) TPSD226K025R0200 ESR = 0.200Ω I_{RMS} = 0.775A
- C5 AVX (Ta) TPSE227K010R0080 ESR = 0.080Ω I_{RMS} = 1.285A
- Q1 SILICONIX PMOS BV_{DSS} = 20V RDS_{ON} = 0.100Ω CRSS = 400pF Q_g = 50nC
- D1 MOTOROLA SCHOTTKY VBR = 30V
- R2 KRL SP-1/2-A1-0R100J Pd = 0.75W
- L1 COILTRONICS CTX100-4 DCR = 0.175Ω Kool Mμ CORE

ALL OTHER CAPACITORS ARE CERAMIC

QUIESCENT CURRENT = 190μA
 TRANSITION CURRENT (Burst Mode OPERATION/
 CONTINUOUS OPERATION) = 170mA

AN54 • F14A

Figure 14A. LTC1147: (5V-14V to 5V/1A) Buck Converter with Surface Mount Technology

LTC1147: (4V-14V to 3.3V/1A) Buck Converter with Surface Mount Technology

Figure 15A shows another compact circuit with the LTC1147 series. It generates 3.3V/1A output using the same configuration as in the previous example. Despite the lack of synchronous rectification, efficiency approaches 95% with 5V input.

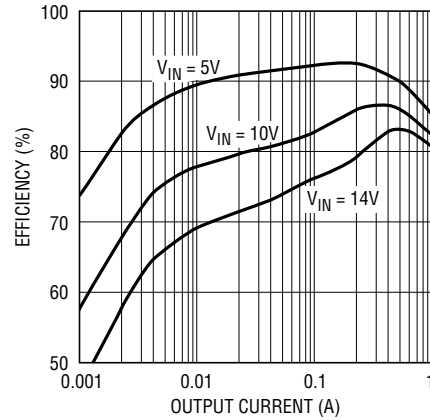

ANS4 • F15B

Figure 15B. LTC1147: (4V-14V to 3.3V/1A) Buck Converter Measured Efficiency

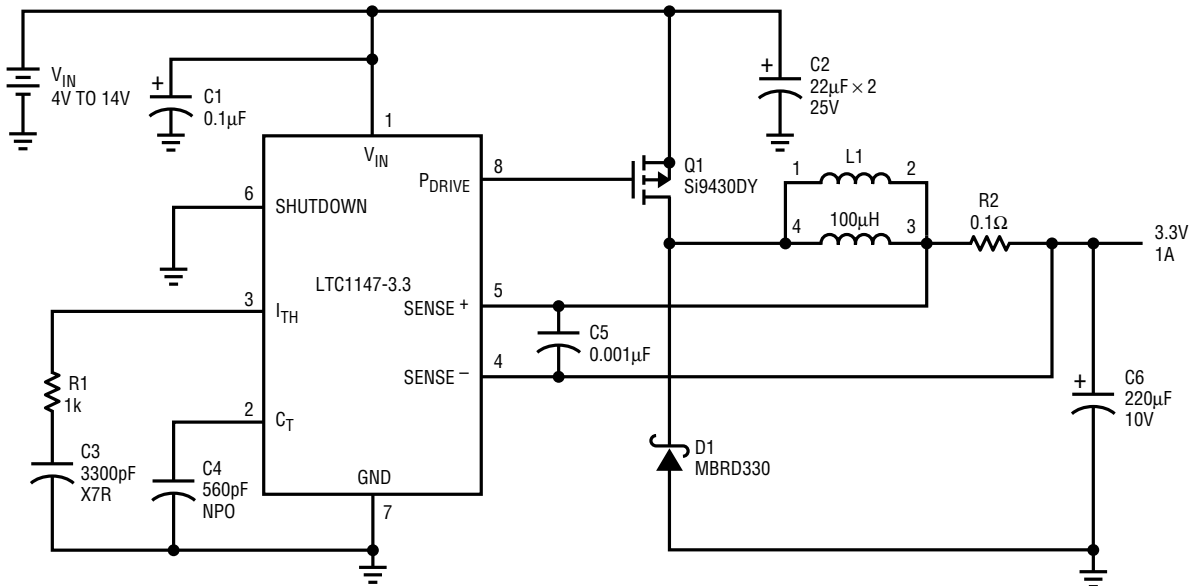

- C2 AVX (Ta) TPSD226K025R0200 ESR = 0.200Ω I_{RMS} = 0.775A
- C6 AVX (Ta) TPSE227K010R0080 ESR = 0.080Ω I_{RMS} = 1.285A
- Q1 SILICONIX BV_{DSS} = 20V DCR_{ON} = 0.100Ω C_{RSS} = 400pF Q_g = 50nC
- D1 MOTOROLA
- R2 KRL SP-1/2-A1-0R100 Pd = 0.75W
- L1 COILTRONICS CTX100-4 DCR = 0.175Ω Kool Mµ CORE

QUIESCENT CURRENT = 170µA
 TRANSITION CURRENT (Burst Mode OPERATION/CONTINUOUS OPERATION) = 170mA

ANS4 • F15A

Figure 15A. LTC1147: (4V-14V to 3.3V/1A) Buck Converter with Surface Mount Technology

Application Note 54

LTC1147: (4V-8V to 3.3V/1.5A) Buck Converter with Surface Mount Technology

One more application circuit with LTC1147 is presented in Figure 16A. It is optimized for 5V to 3.3V conversion with input voltages of 4V to 8V (limited by the P-channel MOSFET). A circuit board has been laid out for this circuit and has subsequently been thoroughly tested under full operating conditions and optimized for mass production requirements. A Gerber file for the board is available upon request.

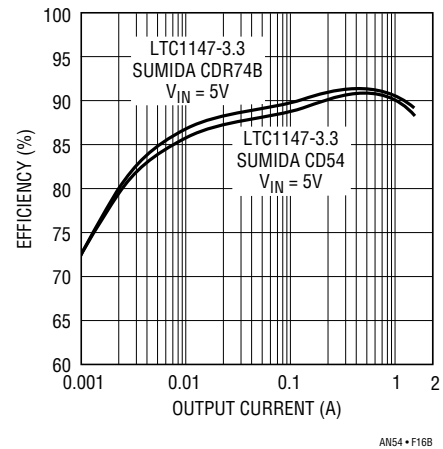
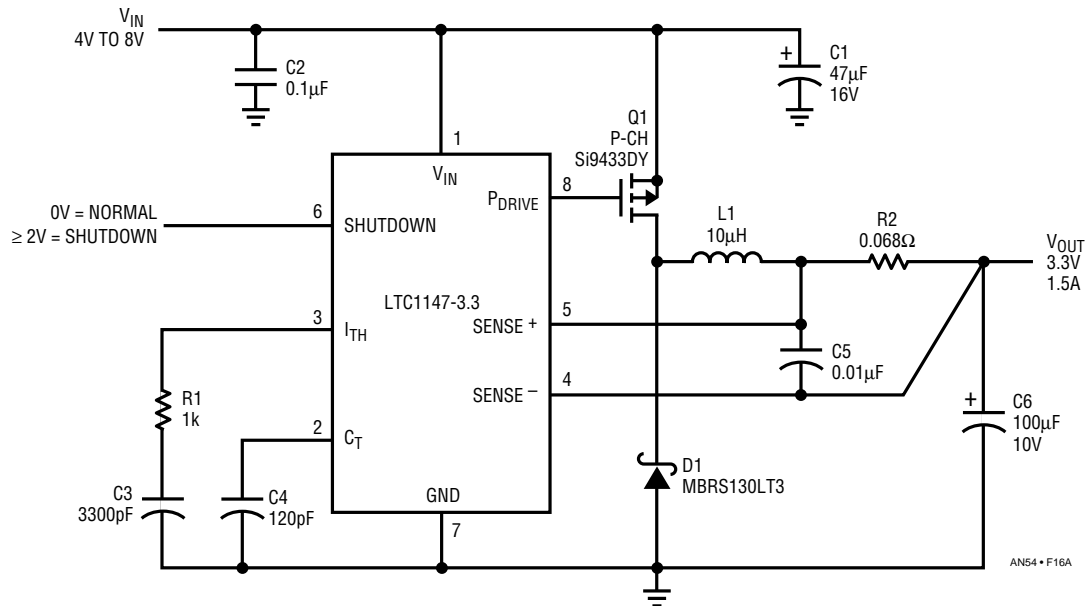

Figure 16B. LTC1147: (4V-8V to 3.3V/1.5A) Buck Converter Measured Efficiency



- C1 AVX TPSD476M016R0150 TANTALUM 47μF 16V
- C6 AVX TPSD107M010R0100 TANTALUM 100μF 10V
- D1 MOTOROLA MBRS130LT3 BVR = 30V
- L1 SUMIDA CDR74B-100LC 10 μH
- Q1 SILICONIX PMOS Si9433
- R2 IRC LRC-LR2010-01-R068-F
- ALL OTHER CAPACITORS CERAMIC

Figure 16A. LTC1147: (4V-8V to 3.3V/1.5A) Buck Converter with Surface Mount Technology

LTC1148: (10V-14V to 5V/10A) High Current Buck Converter

Due to differences in physical structure between N- and P-channel MOSFETs, the former are usually more cost effective, more available, and provide better internal parameters for the same size. This is especially important when high output currents are required. With 5A to 10A output currents the use of N-channel MOSFETs in place of P-channel is the most preferable solution. An implementation of this idea is presented in Figure 17A.

A special Q4 gate drive circuit that uses a bootstrapping technique is added to provide required gate drive. When pin 1 goes high it turns Q3 on, providing a path for fast Q4 gate capacitance discharge. With Q3 off, Q1 and Q2 saturate each other feeding positive voltage to Q4's gate. As a result Q4 turns on, and the positive pulse at its source is AC coupled through C6 supplying bootstrapped V_{CC} for the gate drive "SCR." The external LTC driver circuit contains

only inexpensive, readily available small-signal transistors, yet allows the use of all N-channel MOSFETs. Efficiency reaches 96% (see Figure 17B).

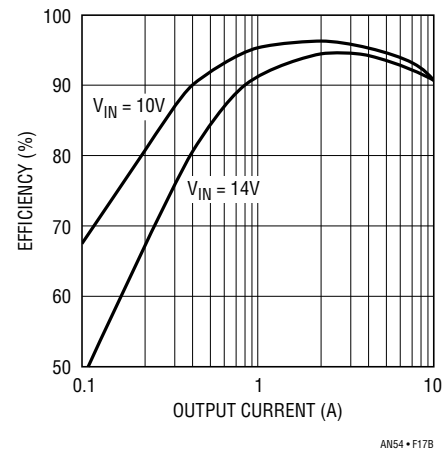
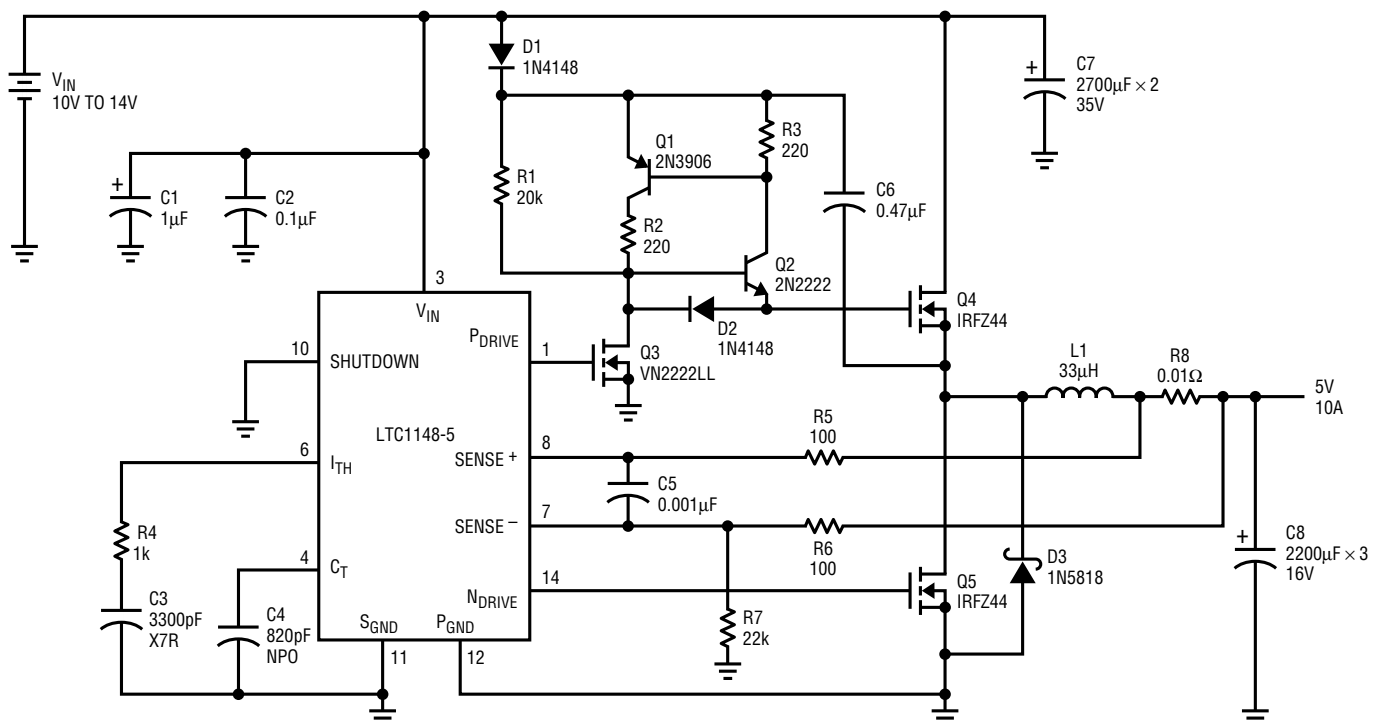

Figure 17B. LTC1148: (10V-14V to 5V/10A) High Current Buck Converter Measured Efficiency



- C1 (Ta)
- C7 UNITED CHEMI-CON (AI) LXF35VB272M16 X 40 ESR = 0.018Ω I_{RMS} = 2.900A
- C8 NICHICON (AI) UPL1C222MRH ESR = 0.028Ω I_{RMS} = 2.010A
- Q4, Q5 IR NMOS $BV_{DSS} = 60V$ $DCR_{ON} = 0.028\Omega$ $C_{RSS} = 310pF$ $Q_g = 69nC$
- D1, D2 MOTOROLA SILICON VBR = 75V
- D3 MOTOROLA SCHOTTKY VBR = 30V

- R8 KRL NP-2A-C1-0R010J Pd = 3W
- L1 COILTRONICS CTX33-10-KM DCR = 0.010Ω Kool Mµ CORE
- ALL OTHER CAPACITORS ARE CERAMIC
- QUIESCENT CURRENT = 22mA

Figure 17A. LTC1148: (10V-14V to 5V/10A) High Current Buck Converter

Application Note 54

Two resistors are placed in series with the current sense pins. This significantly improves circuit noise immunity which is of great importance when switching high current. R7, connected between pin 7 and ground, disables Burst Mode operation so that the regulator operates continuously.

LTC1149: (12V-36V to 5V/5A) High Current, High Voltage Buck Converter

Figure 18A shows a high current, high voltage buck converter. The LTC1149 is used to accommodate the input voltage requirement. As in Figure 17A the top N-channel MOSFET is driven by an external circuit which inverts the chip's P-drive output and uses bootstrapping to provide positive gate-source voltage. The peak-to-peak gate voltage is defined by the DC portion of the gate driver V_{CC} . Therefore, not to exceed maximum gate voltage for the MOSFET, D1's anode is connected to internal 10V regulator output. In this application P_{DRIVE} pin 4 is used because

an output referenced to ground is required. P_{GATE} pin 1 provides the same drive signal referenced to V_{CC} .

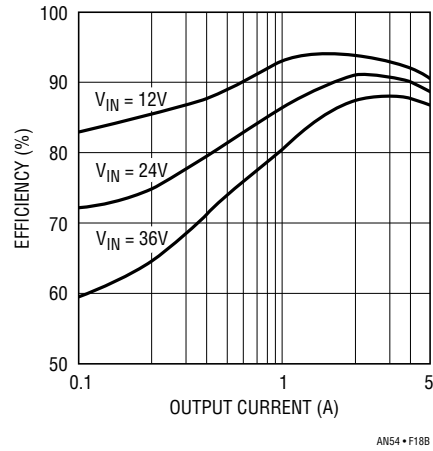
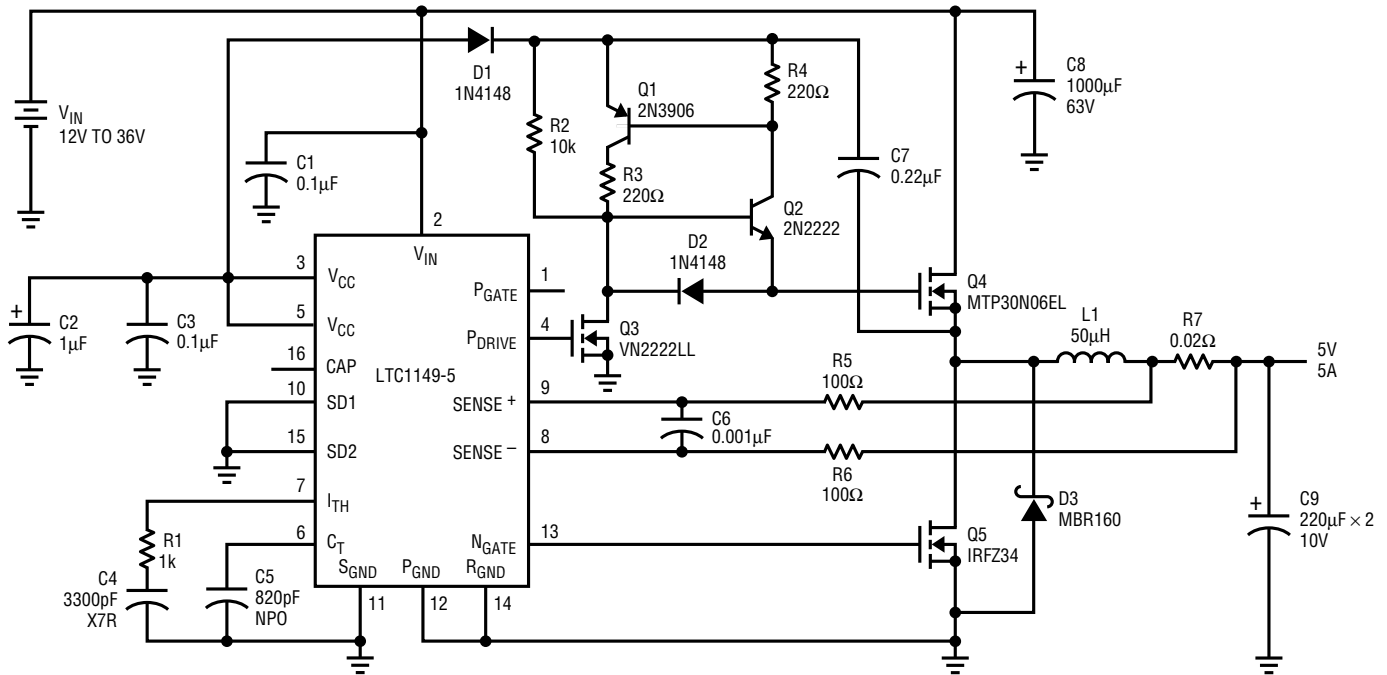

Figure 18B. LTC1149: (12V-36V to 5V/5A) High Current, High Voltage Buck Converter Measured Efficiency



- C2 (Ta)
- C8 NICHICON (AI) UPL1J102MRH ESR = 0.027Ω I_{RMS} = 2.370A
- C9 SANYO (OS-CON) 10SA220M ESR = 0.035Ω I_{RMS} = 2.360A
- Q1 PNP BV_{CEO} = 30V
- Q2 NPN BV_{CEO} = 40V
- Q3 SILICONIX NMOS BV_{DSS} = 60V RDS_{ON} = 5.000Ω
- Q4 MOTOROLA NMOS BV_{DSS} = 60V RDS_{ON} = 0.050Ω C_{RSS} = 100pF Q_g = 40nC

- Q5 IR NMOS BV_{DSS} = 60V RDS_{ON} = 0.050Ω C_{RSS} = 100pF Q_g = 32nC
- D1, D2 SILICON VBR = 75V
- D3 MOTOROLA SCHOTTKY VBR = 60V
- R7 KRL NP-2A-C1-0R020J Pd = 3W
- L1 COILTRONICS CTX50-5-52 DCR = 0.021Ω #52 IRON POWDER CORE

ALL OTHER CAPACITORS ARE CERAMIC

ANS4 • F18A

Figure 18A. LTC1149: (12V-36V to 5V/5A) High Current, High Voltage Buck Converter

LTC1149: (12V-48V to 5V/10A) High Current, High Voltage Buck Converter

The circuit in Figure 19A uses the same configuration but is designed to provide up to 10A output current. Besides the usual external component changes, the circuit uses higher current MOSFETs to improve efficiency at maximum power levels. Efficiency at 5A output is several percentage points better than in the previous example (compare Figures 18B and 19B). R7 keeps the regulator in continuous mode causing the rapid efficiency decrease at lighter loads.

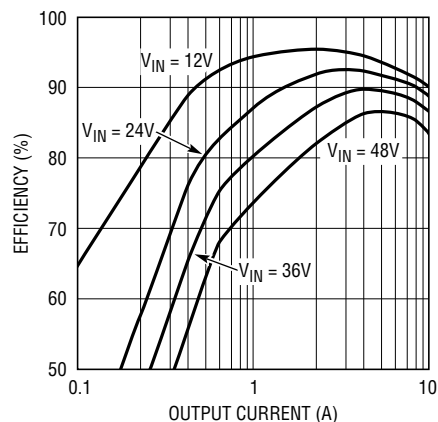

ANS4 • F19B

Figure 19B. LTC1149: (12V-48V to 5V/10A) High Current, High Voltage Buck Converter Measured Efficiency

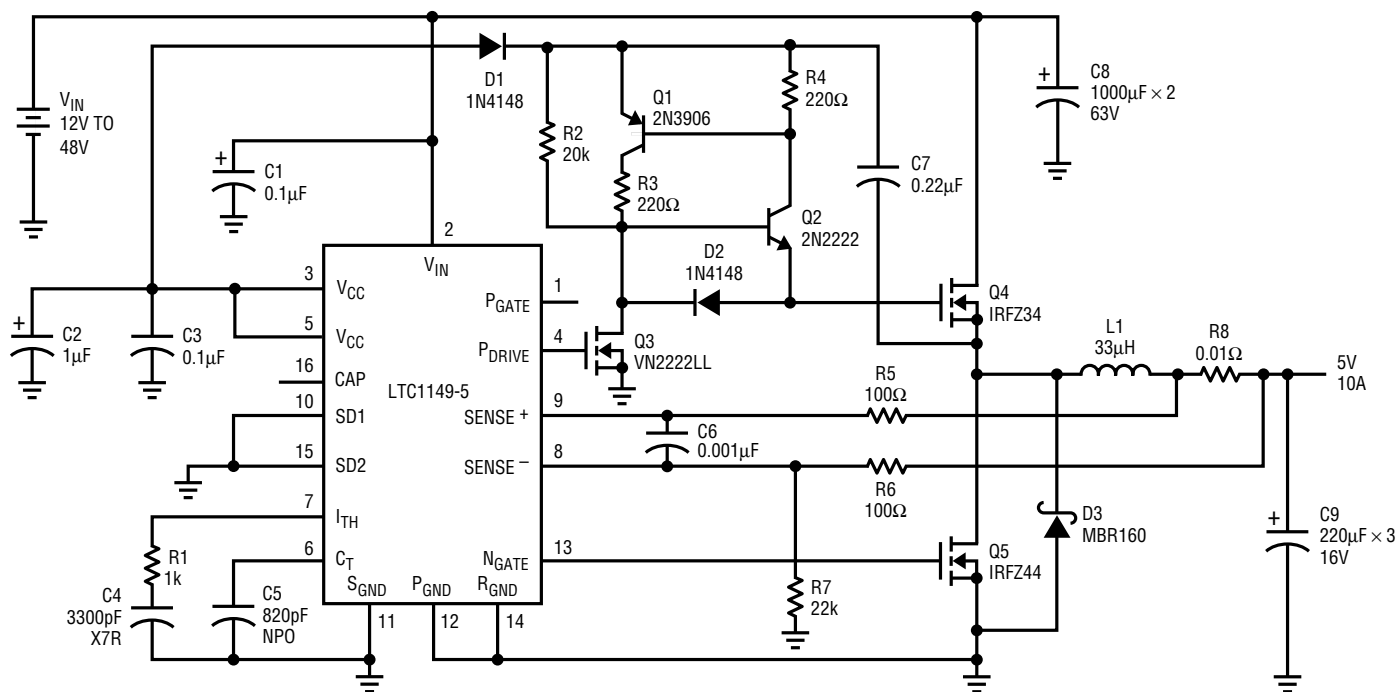

- C2 (Ta)
- C8 NICHICON (AI) UPL1J102MRH ESR = 0.027Ω I_{RMS} = 2.370A
- C9 NICHICON (AI) UPL1C222MRH ESR = 0.028Ω I_{RMS} = 2.010A
- Q1 PNP BV_{CEO} = 30V
- Q2 NPN BV_{CEO} = 40V
- Q3 SILICONIX NMOS BV_{DSS} = 60V RDS_{ON} = 5.000Ω
- Q4 IR NMOS BV_{DSS} = 60V RDS_{ON} = 0.050Ω C_{RSS} = 100pF Q_g = 32nC
- Q5 IR NMOS BV_{DSS} = 60V RDS_{ON} = 0.028Ω C_{RSS} = 310pF Q_g = 69nC

- D1, D2 SILICON VBR = 75V
- D3 MOTOROLA SCHOTTKY VBR = 60V
- R8 KRL NP-2A-C1-0R010J Pd = 3W
- L1 COILTRONICS CTX33-10-KM DCR = 0.010Ω Kool Mμ CORE

ALL OTHER CAPACITORS ARE CERAMIC

QUIESCENT CURRENT = 26mA

ANS4 • F19A

Figure 19A. LTC1149: (12V-48V to 5V/10A) High Current, High Voltage Buck Converter

Application Note 54

LTC1149: (32V-48V to 24V/10A) High Current, High Voltage Buck Converter

If an output voltage other than 5V or 3.3V is required, an adjustable version of the regulator must be used. A 24V/10A example is shown in Figure 20A. The output voltage is set by resistors R8 and R9. The LTC1149 monitors V_{FB} (pin 10) keeping it at 1.25V. Similar to the previous two circuits, an external gate driver is added to switch the N-channel MOSFET Q2. To ensure consistent start-up of the bootstrapping circuitry, the driver is initially powered by R2 and D2. (The main requirement at start-up is to supply the driver with V_{CC} that exceeds output target voltage.) After the switching starts, D1 and D3 power the external gate drive circuit.

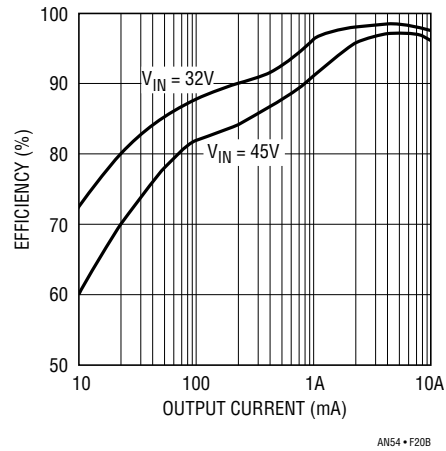
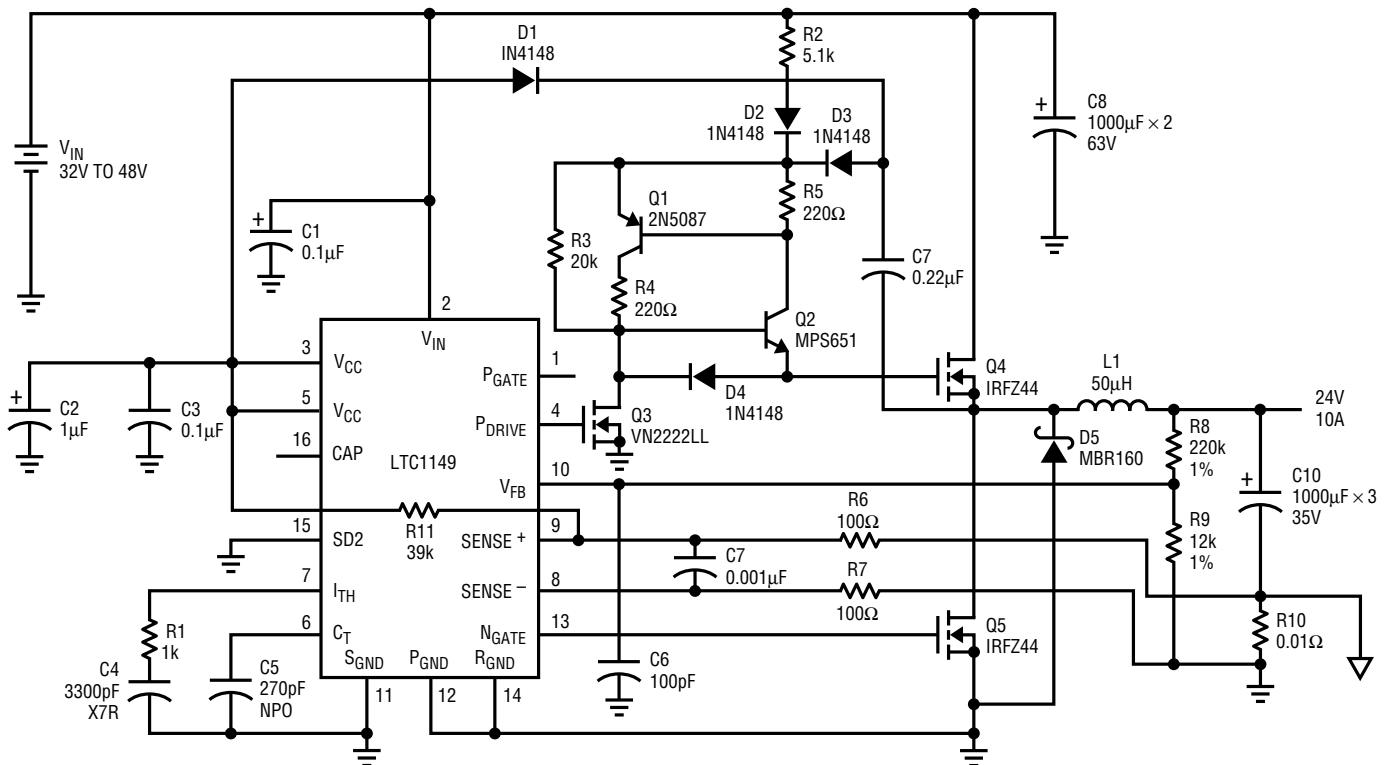

Figure 20B. LTC1149: (32V-48V to 24V/10A) High Current, High Voltage Buck Converter Measured Efficiency



- C2 (Ta)
- C9 NICHICON (AI) UPL1J102MRH ESR = 0.027Ω I_{RMS} = 2.370A
- C10 NICHICON (AI) UPL1V102MRH ESR = 0.029Ω I_{RMS} = 1.980A
- Q4, Q5 IR NMOS BV_{DSS} = 60V RDS_{ON} = 0.028Ω C_{RSS} = 310pF Q_g = 69nC
- Q1 PNP BV_{CEO} = 50V
- Q2 NPN BV_{CEO} = 60V
- D1, D2, D3, D4 SILICON VBR = 75V
- D5 MOTOROLA SCHOTTKY VBR = 60V
- R10 KRL NP-2A-C1-0R010J Pd = 3W
- L1 COILTRONICS CTX50-10-KM DCR = 0.010Ω Kool M_μ CORE

$V_{OUT} = 1.25V (1 + R8/R9)$
 QUIESCENT CURRENT = 26mA
 TRANSITION CURRENT (Burst Mode OPERATION/CONTINUOUS OPERATION) = 1.5A

ALL OTHER CAPACITORS ARE CERAMIC

ANS4 • F20A

Figure 20A. LTC1149: (32V-48V to 24V/10A) High Current, High Voltage Buck Converter

LT1148: (4V-14V to 5V/1A) SEPIC Converter

Figure 21A provides the function of a step-up and step-down converter without using a transformer. This topology is called a SEPIC converter. The P-channel transistor and L1 are arranged similarly to a buck-boost topology providing the boost part of the regulator. Pulses at Q2's drain (actually two paralleled devices) are coupled via C8 to the buck portion that includes Q3 and L2. This circuit accepts 4V to 14V input and provides a solid 5V output. Even though the schematic shows two inductors, they carry the same current and can be wound on a single core. Such dual coils are readily available (see circuit parts list). This topology is acceptable for moderate loads only, as the coupling capacitor C8 carries the full load current and must be sized accordingly. When the sense resistor is placed at ground potential, such as the case in this circuit, the off-time increases approximately 40%.

An adjustable version of the regulator is required when the

current sense resistor is placed at ground. This allows to provide different output voltages. D2 is included for foldback short-circuit protection. When V_{OUT} equals zero (output is shorted) D2 clamps pin 6 and limits the output current.

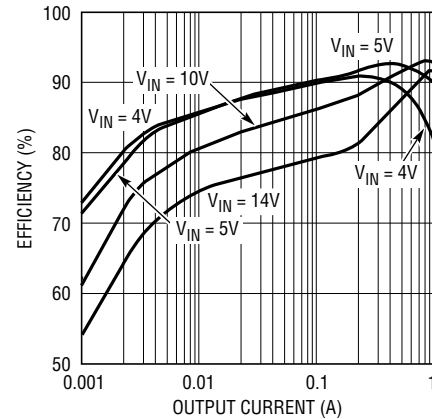
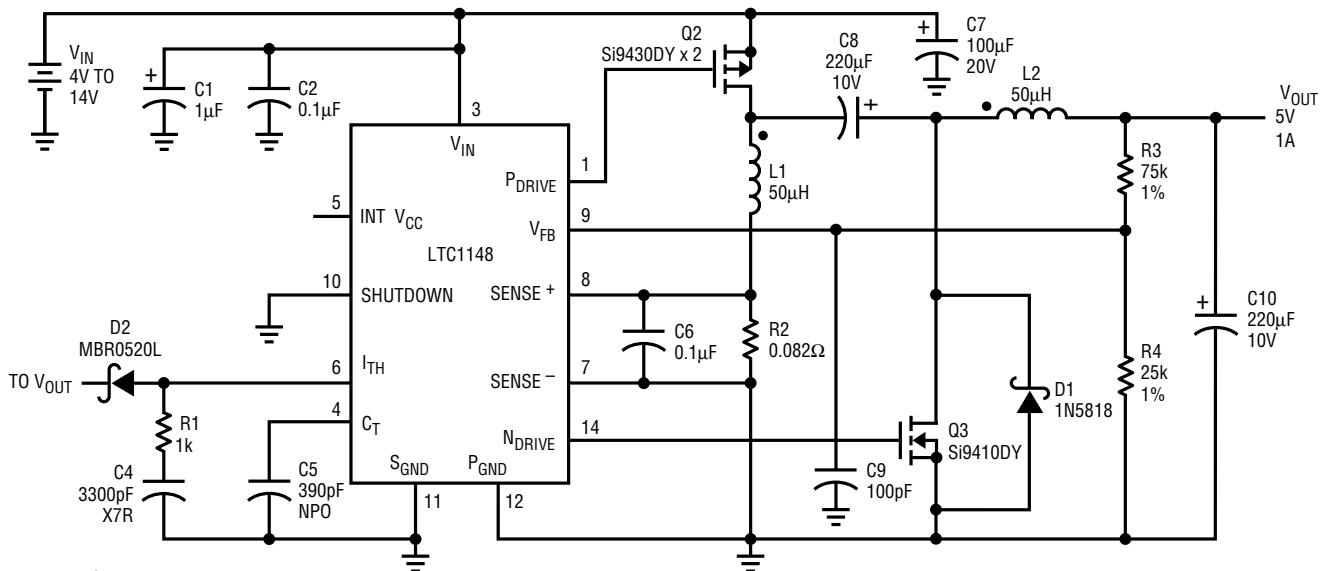

Figure 21B. LTC1148: (4V-14V to 5V/1A) Buck-Boost Converter Measured Efficiency



- C1 (Ta)
- C7 SANYO (OS-CON) 20SA100M ESR = 0.037Ω I_{RMS} = 2.250A
- C8, C10 SANYO (OS-CON) 10SA220M ESR = 0.035Ω I_{RMS} = 2.360A
- Q2 SILICONIX PMOS BV_{DSS} = 20V RDS_{ON} = 0.100Ω C_{RSS} = 400pF Q_g = 50nC
- Q3 SILICONIX NMOS BV_{DSS} = 30V RDS_{ON} = 0.050Ω C_{RSS} = 160pF Q_g = 30nC
- D1 MOTOROLA SCHOTTKY VBR = 30V
- R2 KRL NP-1A-C1-0R082J Pd = 1W
- L1 COILTRONICS CTX50-4P, CTX50-5P

$V_{OUT} = 1.25V (1 + R3/R4)$
 QUIESCENT CURRENT = 200µA
 TRANSITION CURRENT (Burst Mode OPERATION/
 CONTINUOUS OPERATION) = 250mA/V_{IN} = 5V

ALL OTHER CAPACITORS ARE CERAMIC

ANS4 • F21A

Figure 21A. LTC1148: (4V-14V to 5V/1A) SEPIC Converter

Application Note 54

LTC1148: (4V-14V to 5V/0.5A, -5V/0.5A) Split Supply Converter

Applications requiring a split supply can use the circuit presented in Figure 22A. It contains the converter from Figure 21A and adds a synchronous charge pump Q4 to provide a -5V output. Q4 source is referenced to the -5V line, and its gate drive is AC coupled via C11 and clamped by D3. The outputs exhibit excellent tracking with line and load changes. This is a great way to build a dual output converter without any transformer.

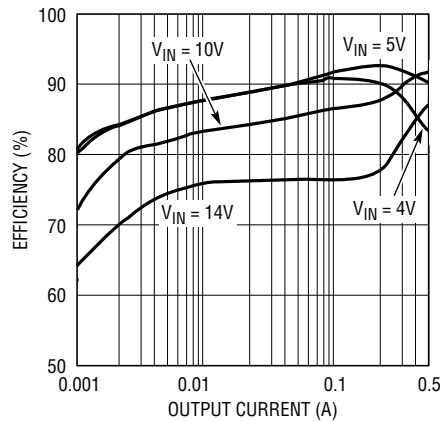

Figure 22B. LTC1148: (4V-14V to 5V/0.5A, -5V/0.5A) Split Supply Converter Measured Efficiency

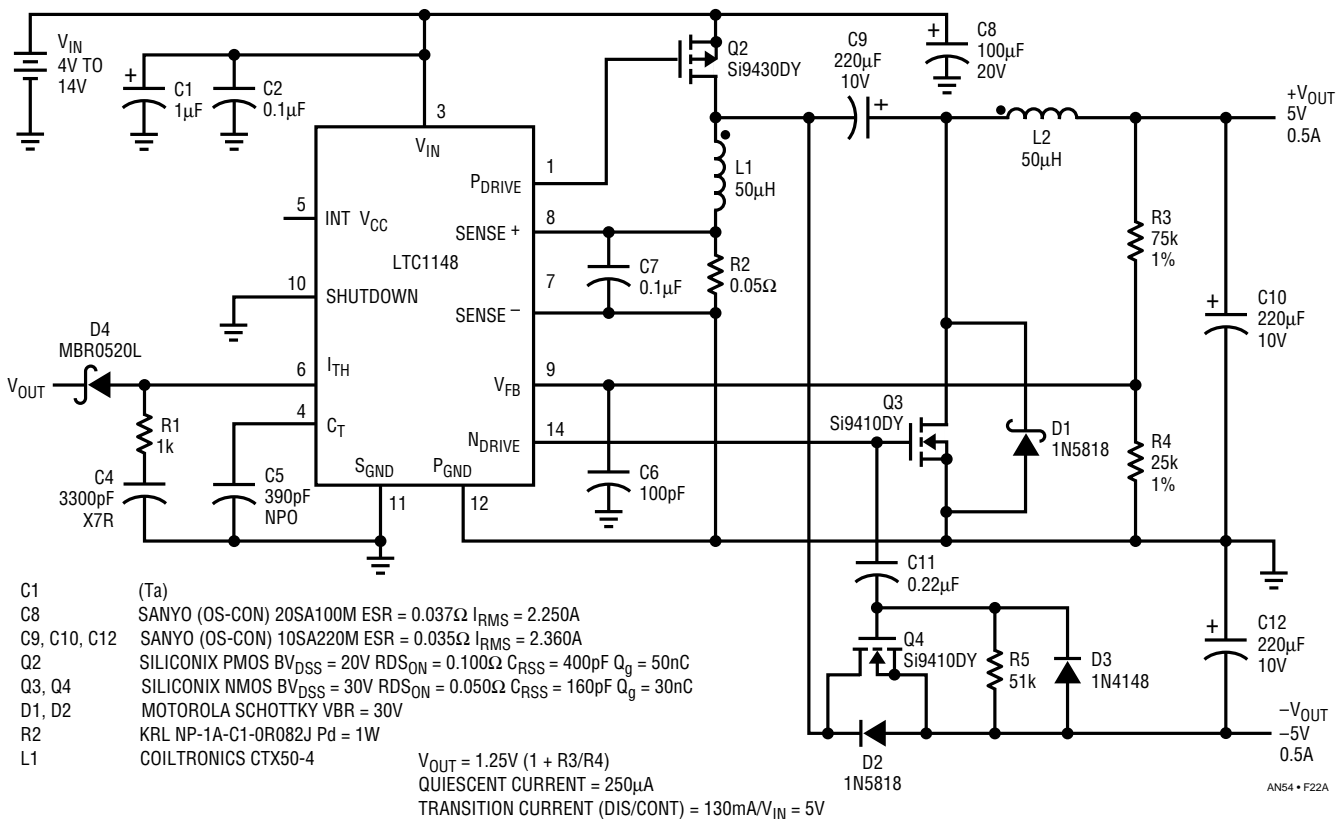

Figure 22A. LTC1148: (4V-14V to 5V/0.5A, -5V/0.5A) Split Supply Converter

LTC1148: (4V-10V to -5V/1A) Positive-to-Negative Converter

Figure 23A shows a buck-boost converter using the LTC1148. This is an inverting topology, and it can inherently buck or boost the input voltage. Ground pins of the chip are referenced to the output line; no additional level shifting circuit is required to drive the N-channel FET Q3 (its source is referenced to -5V as well). Now even with minimum input level, the circuit provides a solid 9V peak-to-peak MOSFET drive signal. However, so as not to exceed absolute maximum voltage at pin 3, the input line is limited to 10V. If the circuit is required to accept a higher input voltage, the LTC1148HV can be used instead. Q1 is added to provide a logic level shutdown feature. If shutdown is not needed omit Q1 and R1, and short pin 10 to pin 11.

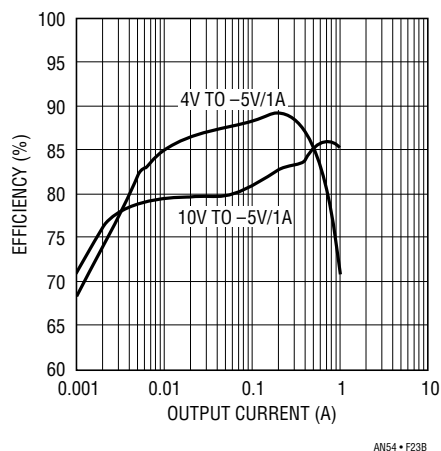
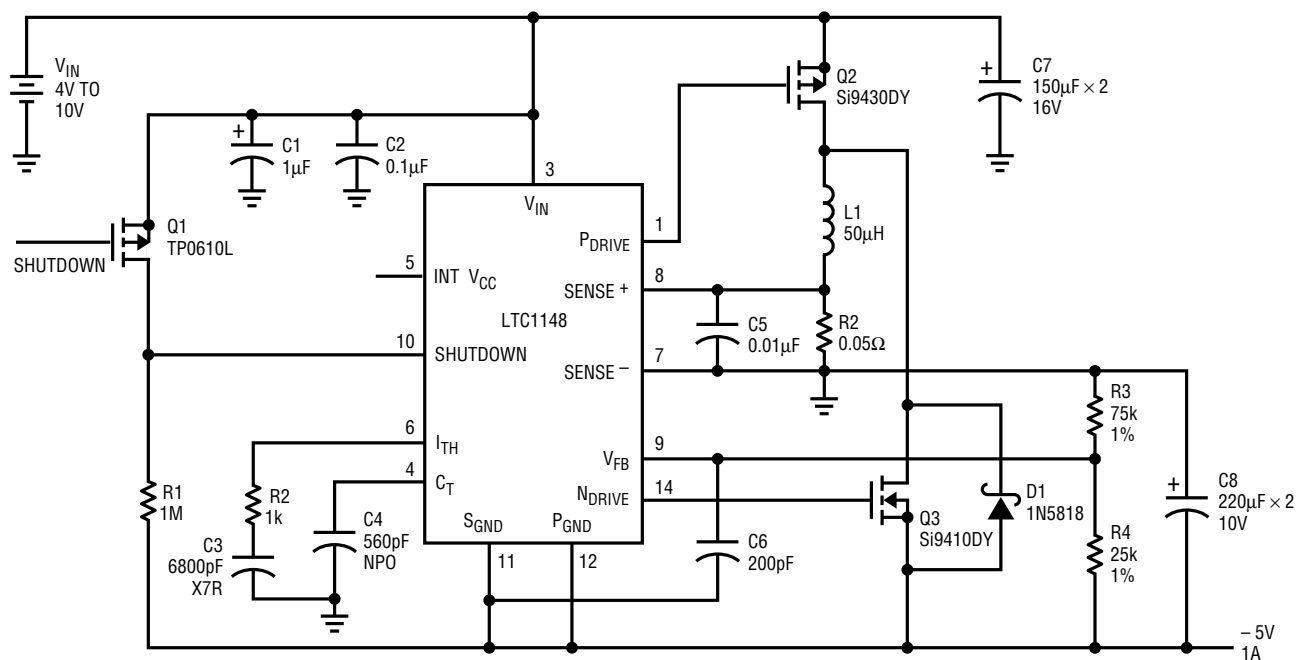

Figure 23B. LTC1148: (4V-10V to -5V/1A) Positive-to-Negative Converter Measured Efficiency



- C1 (Ta)
- C7 SANYO (OS-CON) 16SA150M ESR = 0.035Ω I_{RMS} = 2.280A
- C8 SANYO (OS-CON) 10SA220M ESR = 0.035Ω I_{RMS} = 2.360A
- Q2 SILICONIX PMOS BV_{DSS} = 20V RDS_{ON} = 0.100Ω C_{RSS} = 400pF Q_g = 50nC
- Q3 SILICONIX NMOS BV_{DSS} = 30V RDS_{ON} = 0.050Ω C_{RSS} = 160pF Q_g = 30nC
- D1 MOTOROLA SCHOTTKY VBR = 30V
- R2 KRL NP-1A-C1-0R050J
- L1 COILTRONICS CTX50-2-MP DCR = 0.032Ω MPP CORE

ALL OTHER CAPACITORS ARE CERAMIC

$$V_{OUT} = 1.25V (1 + R3/R4)$$

ANS4 • F23A

Figure 23A. LTC1148: (4V-10V to -5V/1A) Positive-to-Negative Converter

Application Note 54

LTC1148: (5V-12V to -15V/0.5A) Buck-Boost Converter

Figure 24A presents an inverting regulator designed to accommodate higher output voltages. The LTC1148 cannot accept feedback directly from a negative output. To regulate negative outputs, the feedback must be inverted and compared against 1.25V. This function is provided by a DC level shifting amplifier consisting of Q1 and associated components. Resistor R4 provides amplifier negative feedback, effectively cancelling variations in V_{CC} , and Q2 provides temperature compensation. The output voltage is set by resistors R4 and R5. As usual, with the sense resistor at ground potential, the off-time increases roughly by 40%.

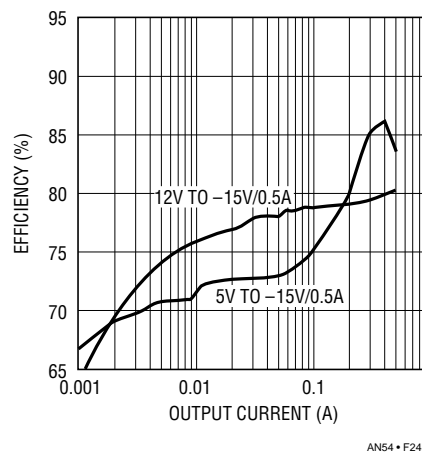

Figure 24B. LTC1148: (5V-12V to -15V/0.5A) Buck-Boost Converter Measured Efficiency

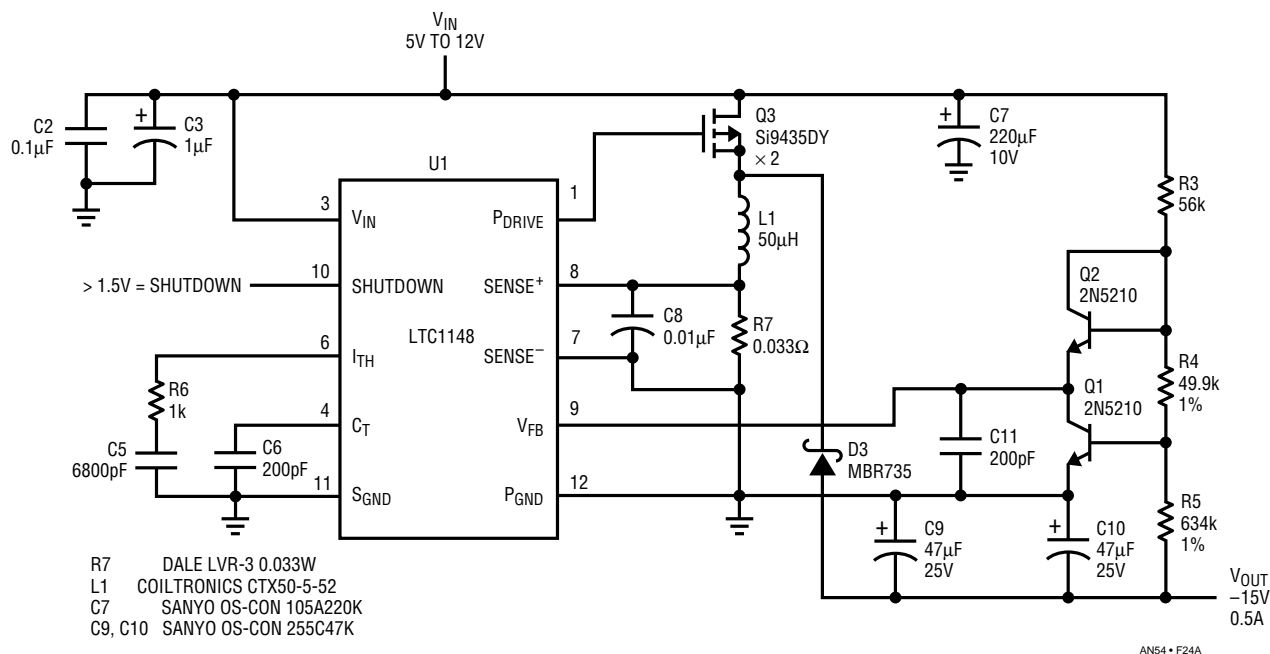

Figure 24A. LTC1148: (5V-12V to -15V/0.5A) Buck-Boost Converter

LTC1148: (2V-5V to 5V/1A) Boost Converter

Even though the LTC1148 is mainly used in step-down converters, it can also show excellent performance in the boost configuration. A boost implementation is shown in Figure 25A. This is a two-cell to 5V converter that uses the LT1109 to provide 12V to power the main regulator chip (unfortunately, MOSFETs do not operate with only 2V at the gate). The LT1109 is a small micropower IC that requires only three external components and provides great efficiency. An N-channel transistor is used as the switch, and general purpose MOSFETs Q1 and Q2 are used to form an inverting gate driver. When Q3 turns off, the voltage at its drain rises above V_{IN} , and a Schottky diode D2 starts conducting. In a short period of time Q4 shorts it out providing a synchronous rectification feature and increasing efficiency. If 12V is already available, the LT1109 can be omitted and the 12V line connected directly to pin 3.

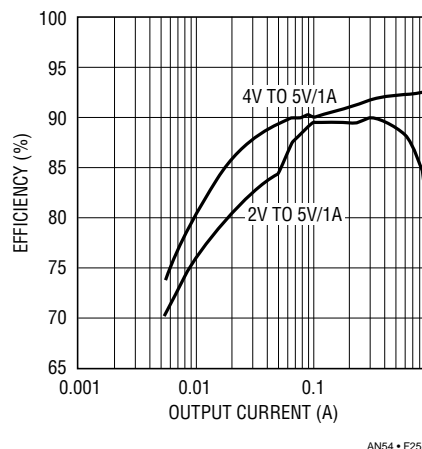
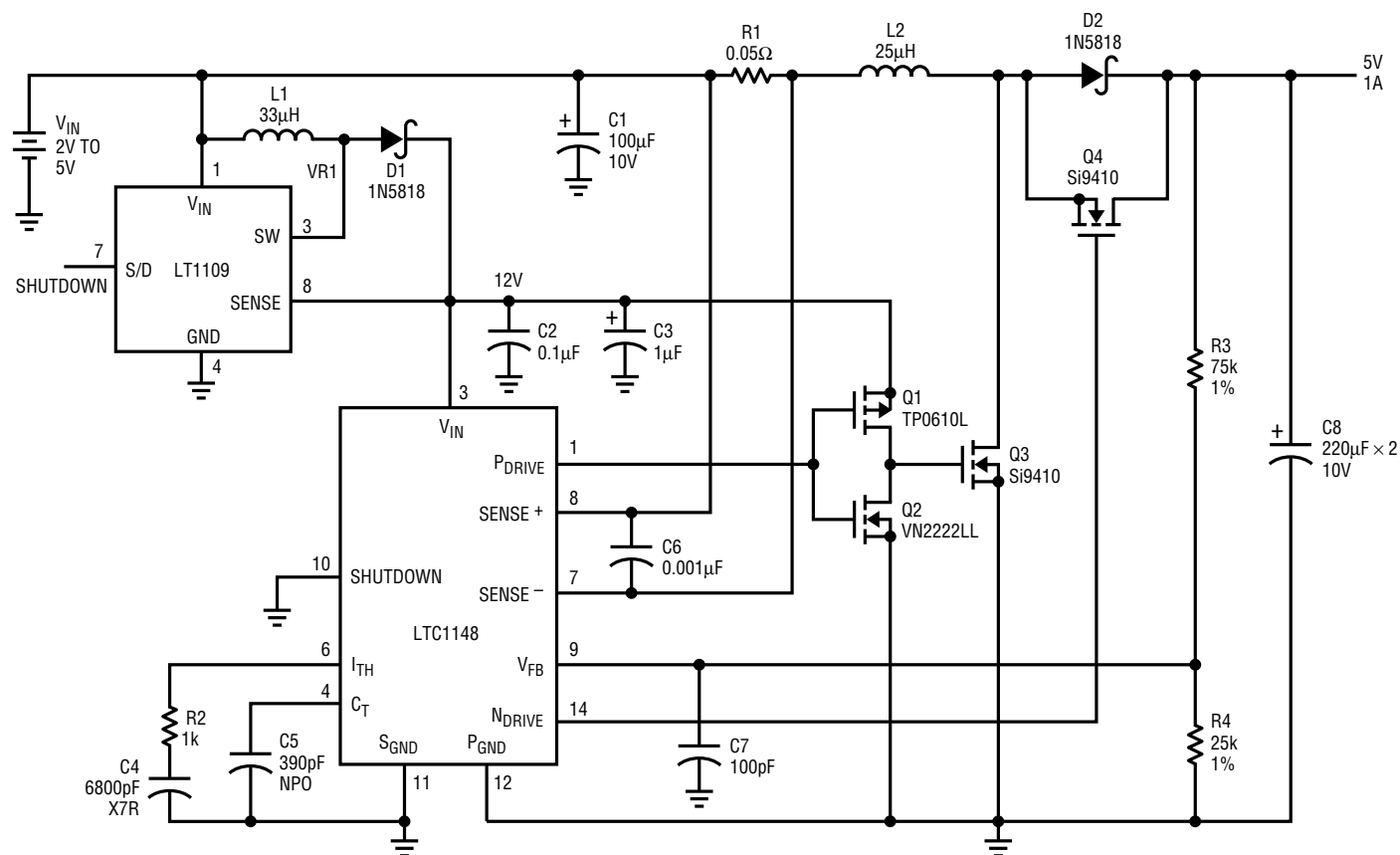

Figure 25B. LTC1148: (2V-5V to 5V/1A) Boost Converter Measured Efficiency



- C1 SANYO (OS-CON) 10SA100M ESR = 0.045Ω I_{RMS} = 1.870A
- C3 (Ta)
- C8 SANYO (OS-CON) 10SA220M ESR = 0.035Ω I_{RMS} = 2.360A
- Q3, Q4 SILICONIX NMOS BV_{DSS} = 30V RDS_{ON} = 0.050Ω C_{RSS} = 160pF Q_g = 30nC
- D1, D2 MOTOROLA SCHOTTKY VBR = 30V

- R2 KRL SL-1-C1-0R050J Pd = 1W
- L1 COILTRONICS CTX33-1 DCR = 0.220Ω Kool Mμ CORE
- L2 COILTRONICS CTX25-4

$V_{OUT} = 1.25V (1 + R3/R4)$

Figure 25A. LTC1148: (2V-5V to 5V/1A) Boost Converter

Application Note 54

LTC1143: (5.2V-14V to 3.3V/2A and 5V/2A) Dual Buck Converter

A circuit that provides dual 3.3V/5V output is shown in Figure 26A. It uses a dual LTC1143 regulator that combines two LTC1147, non-synchronous switching regulators. The efficiency was measured with only one output loaded which provided worse results for low output current due to the presence of the second half's quiescent current. This circuit provides very simple means to power dual voltage logic. It occupies small amount of board space and is very efficient!

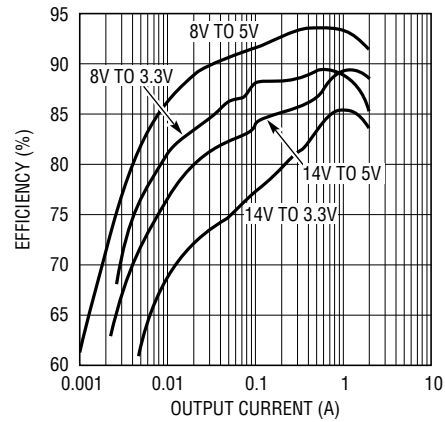

AN54 • F26B

Figure 26B. LTC1143: (5.2V-14V to 3.3V/2A and 5V/2A) Dual Buck Converter Measured Efficiency

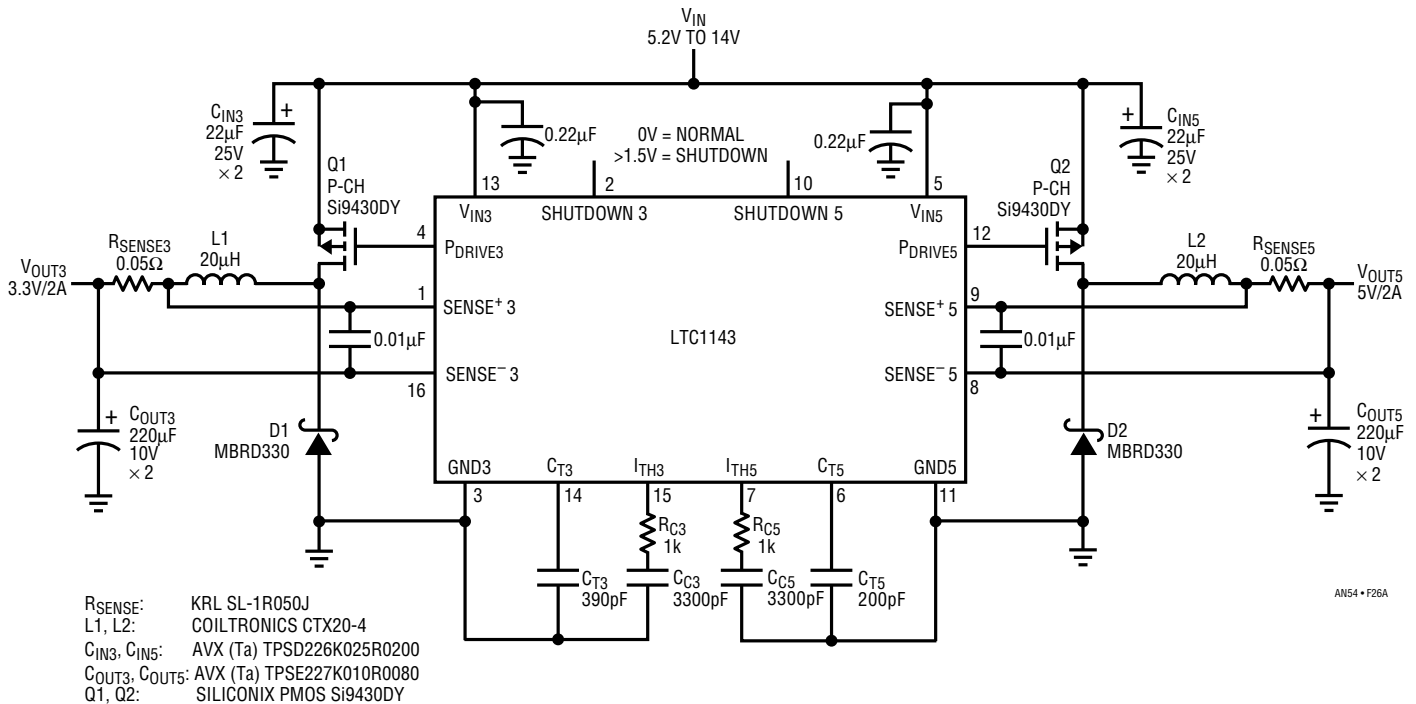

AN54 • F26A

Figure 26A. LTC1143: (5.2V-14V to 3.3V/2A and 5V/2A) Dual Buck Converter

LTC1148HV-5: (5.2V-18V to 5V/1A) High Voltage Buck Converter

The standard LTC1148 input voltage is limited to 16V absolute maximum level, which is not sufficient in some applications. Figure 27A shows a step-down regulator using the high voltage LTC1148HV. It contains the same internal functions but accepts up to 20V input (remember, MOSFET's gates are usually rated at 20V maximum). As a building block it can be used in the same manner as LTC1148. Input tantalum capacitors now have to be rated at 35V to ensure reliable operation under maximum input voltage.

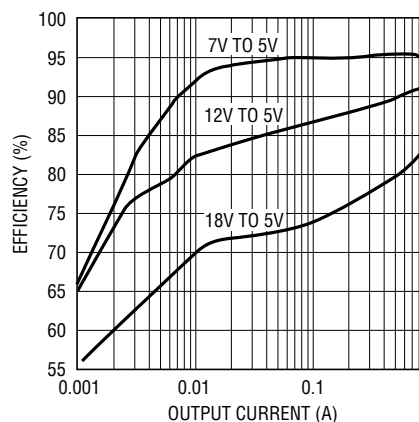

ANS4 • F27B

Figure 27B. LTC1148HV-5: (5.2V-18V to 5V/1A) High Voltage Buck Converter Measured Efficiency

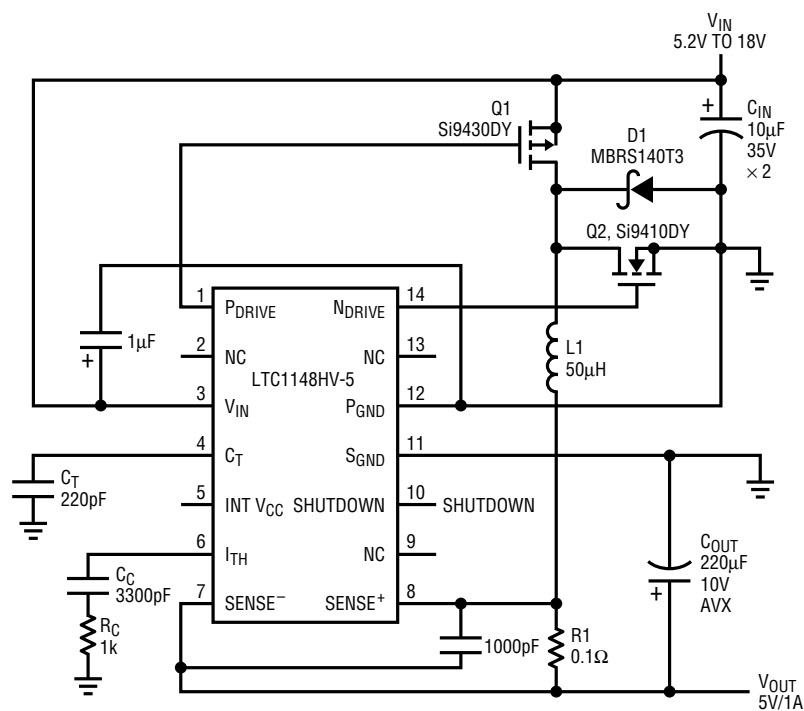

- C_{IN} AVX (Ta) TPSD106K035R0300
- C_{OUT} AVX (Ta) TPSE227K010R0080
- L1 COILTRONICS CTX50-4
- R1 KRL SP-1/2-A1-0R100
- Q1 SILICONIX PMOS Si9430DY
- Q2 SILICONIX NMOS Si9410DY

ANS4 • F27A

Figure 27A. LTC1148HV-5: (5.2V-18V to 5V/1A) High Voltage Buck Converter

Application Note 54

LTC1148HV-3.3 (4V-18V to 3.3V/1A) High Voltage Buck Converter

Figure 28A: Here is a high voltage version of the circuit shown in Figure 4A with input voltage increased to 18V.

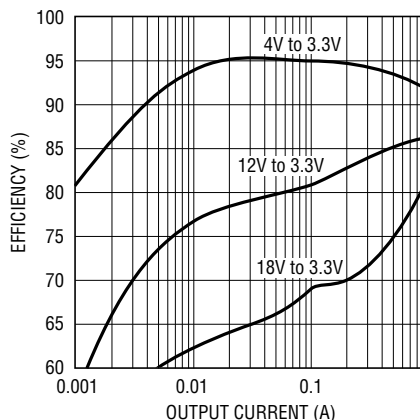

AN54 • F28B

Figure 28B. LTC1148HV-3.3: (4V-18V TO 3.3V/1A) High Voltage Buck Converter Measured Efficiency

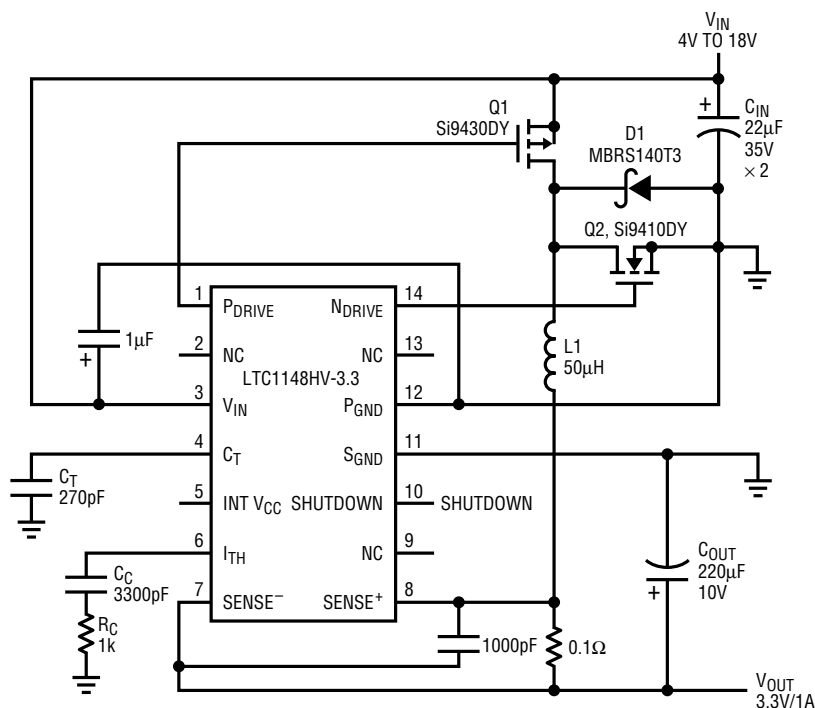

- C_{IN} AVX (Ta) TPSE226K035R0300
- C_{OUT} AVX (Ta) TPSE227K010R0080
- L1 COILTRONICS CTX50-4 Kool Mµ CORE
- R1 IRC LR2010-01-R100-G
- Q1 SILICONIX PMOS Si9430DY
- Q2 SILICONIX NMOS Si9410DY

AN54 • F28A

Figure 28A. LTC1148HV-3.3: (4V-18V to 3.3V/1A) High Voltage Buck Converter

LTC1148HV: (12.5V-18V to 12V/2A) High Voltage Buck Converter

Figure 29A is another application of the LTC1148HV which is configured as a step-down converter to provide 12V/2A output. With this low dropout regulator, the input can go as low as 12.5V and still produce a regulated output. Resistors R2 and R3 set the output voltage level.

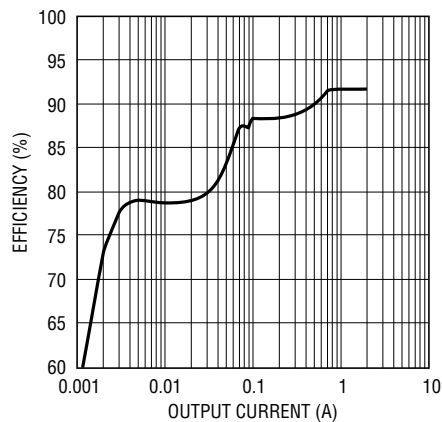

ANS4 • F29B

Figure 29B. LTC1148HV: (16V to 12V/2A) High Voltage Buck Converter Measured Efficiency

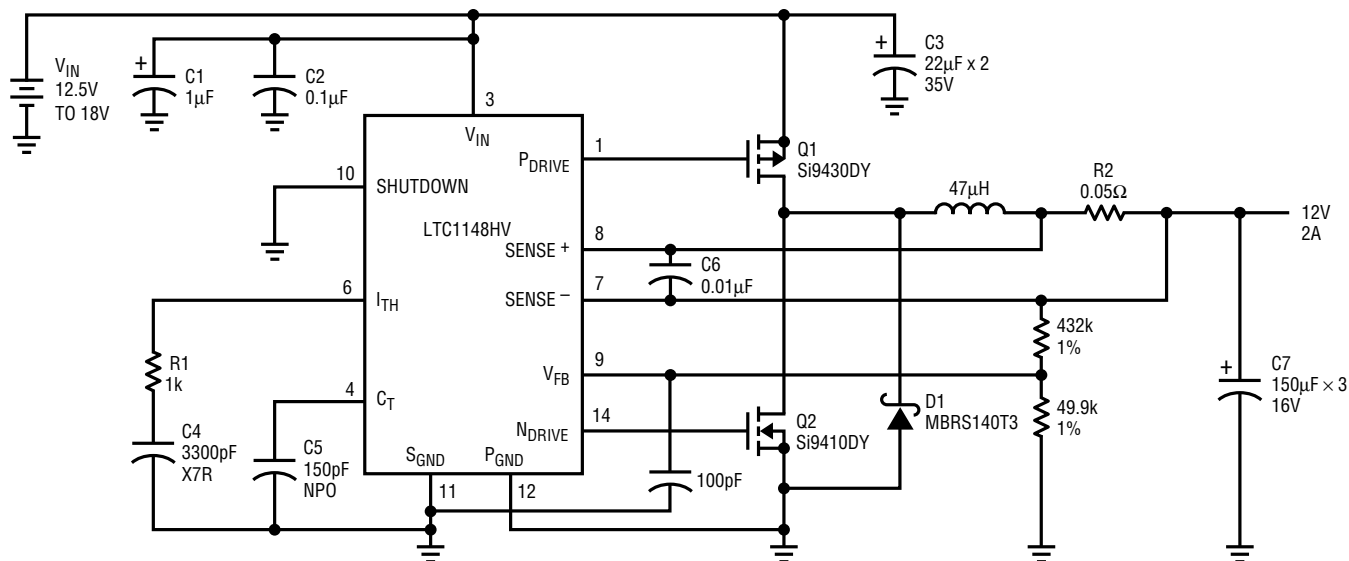

- C1 (Ta)
- C7 SANYO (OS-CON) 16SA150M
- Q1 SILICONIX PMOS $BV_{DSS} = 20V$ $R_{DS(ON)} = 0.100\Omega$ $C_{RSS} = 400pF$ $Q_g = 50nC$
- Q2 SILICONIX NMOS $BV_{DSS} = 30V$ $R_{DS(ON)} = 0.050\Omega$ $C_{RSS} = 160pF$ $Q_g = 30nC$
- D1 MOTOROLA SCHOTTKY VBR = 40V
- R2 KRL SL-1-C1-0R050J Pd = 1W
- L1 COILTRONICS CTX47-5P

ANS4 • F29A

Figure 29A. LTC1148HV: (12.5V-18V to 12V/2A) High Voltage Buck Converter

Application Note 54

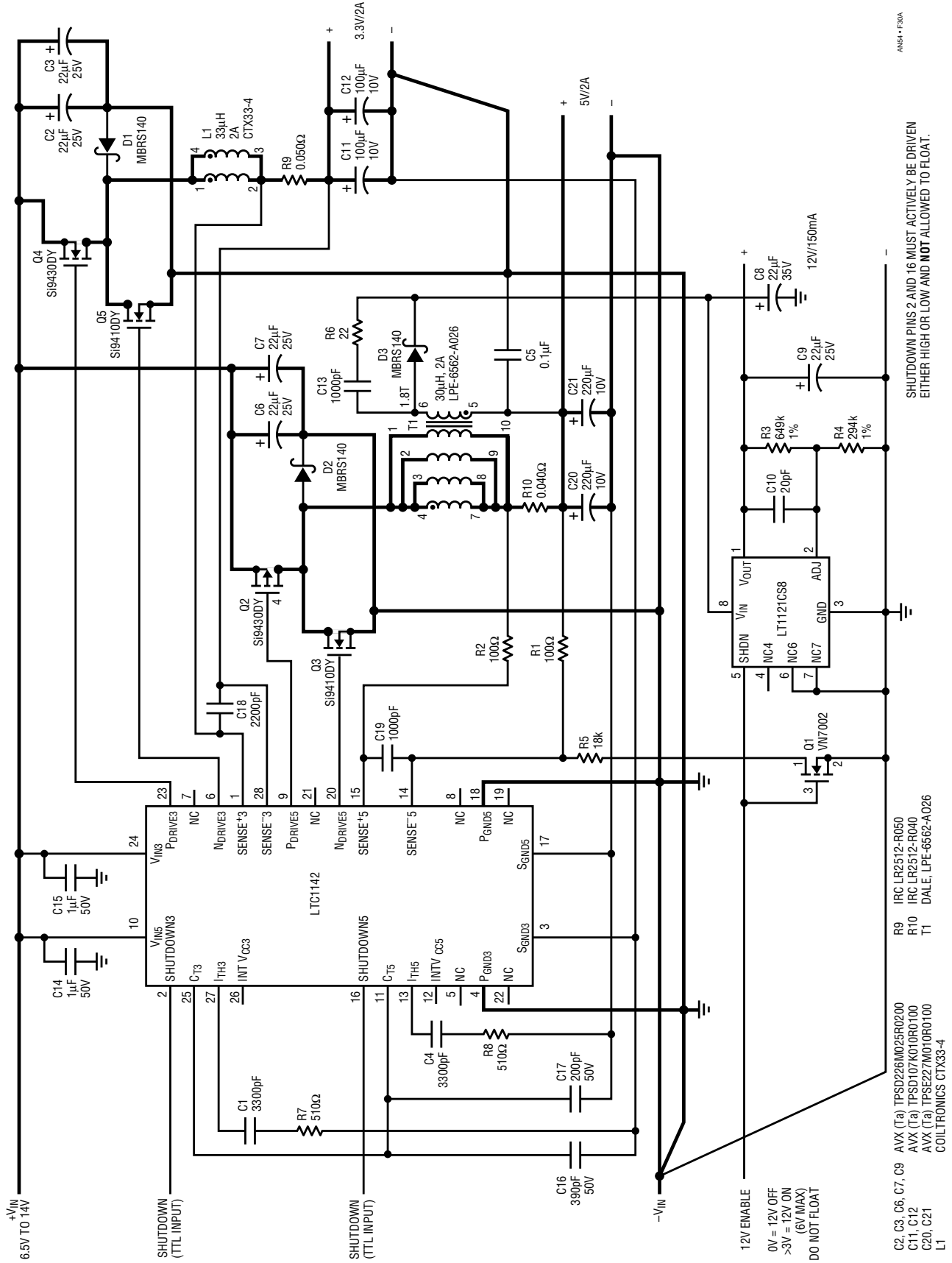

Figure 30A. LTC1142: (6.5V-14V to 3.3V/2A, 5V/2A, 12V/0.15A) Triple Output Buck Converter

LTC1142: (6.5V-14V to 3.3V/2A, 5V/2A, 12V/0.15A) Triple Output Buck Converter

LTC1142 is a dual output synchronous switching regulator controller. Two independent controller blocks (LTC1148-based) simultaneously provide 3.3V and 5V outputs. The circuit in Figure 30A shows an application of this IC; it generates triple output voltages with 12V for flash memory programming in addition to the usual logic power levels. The 3.3V section is a regular buck converter circuit, the 5V section contains an off-the-shelf transformer T1 in place of the inductor. The secondary winding is used to boost the output level which is rectified and regulated by an LT1121 to provide a clean and stable 12V output. A turns ratio of 1:1.8 is used to ensure that the input voltage to the LT1121 is high enough to keep the regulator out of dropout. With LTC1142 synchronous switching, the auxiliary 12V output may be loaded without regard to the 5V primary output load as long as the loop remains in continuous operation mode. Continuous operation is ensured by R5 which inhibits Burst Mode whenever the 12V output is enabled (enable line goes high). Make sure that the enable lines are not floating and are driven by TTL level signals. A circuit board has been laid out for this circuit and has subsequently been thoroughly tested under full operating conditions and optimized for mass production requirements. A Gerber file for the board is available upon request.

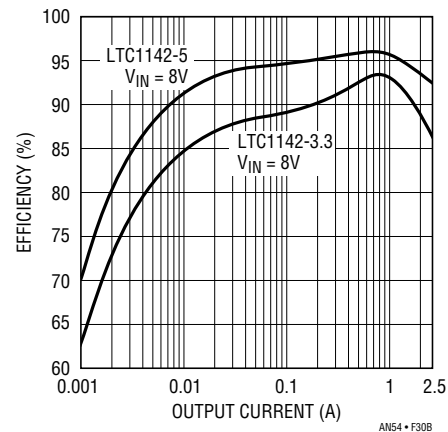

Figure 30B. LTC1142:(6.5V-14V to 3.3V/2A, 5V/2A, 12V/0.15A) Triple Output Buck Converter Measured Efficiency

Application Note 54

LTC1142HV: (6.5V-18V to 3.3V/2A, 5V/2A, 12V/0.15A) High Voltage Triple Output Buck Converter

Figure 31A shows the same configuration as Figure 30A using the high voltage LTC1142HV. Circuit operation is identical, but now it can accept up to 18V at the input.

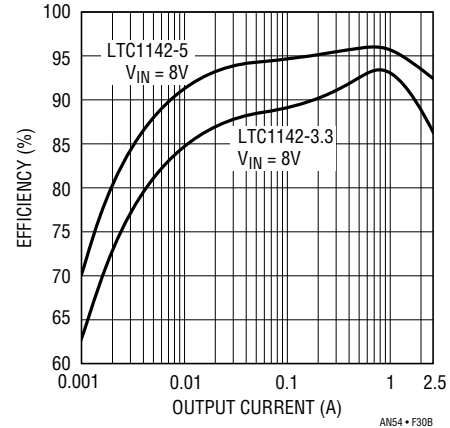

Figure 31B. LTC1142HV: (6.5V-18V to 3.3V/2A, 5V/2A, 12V/0.15A) Measured Efficiency

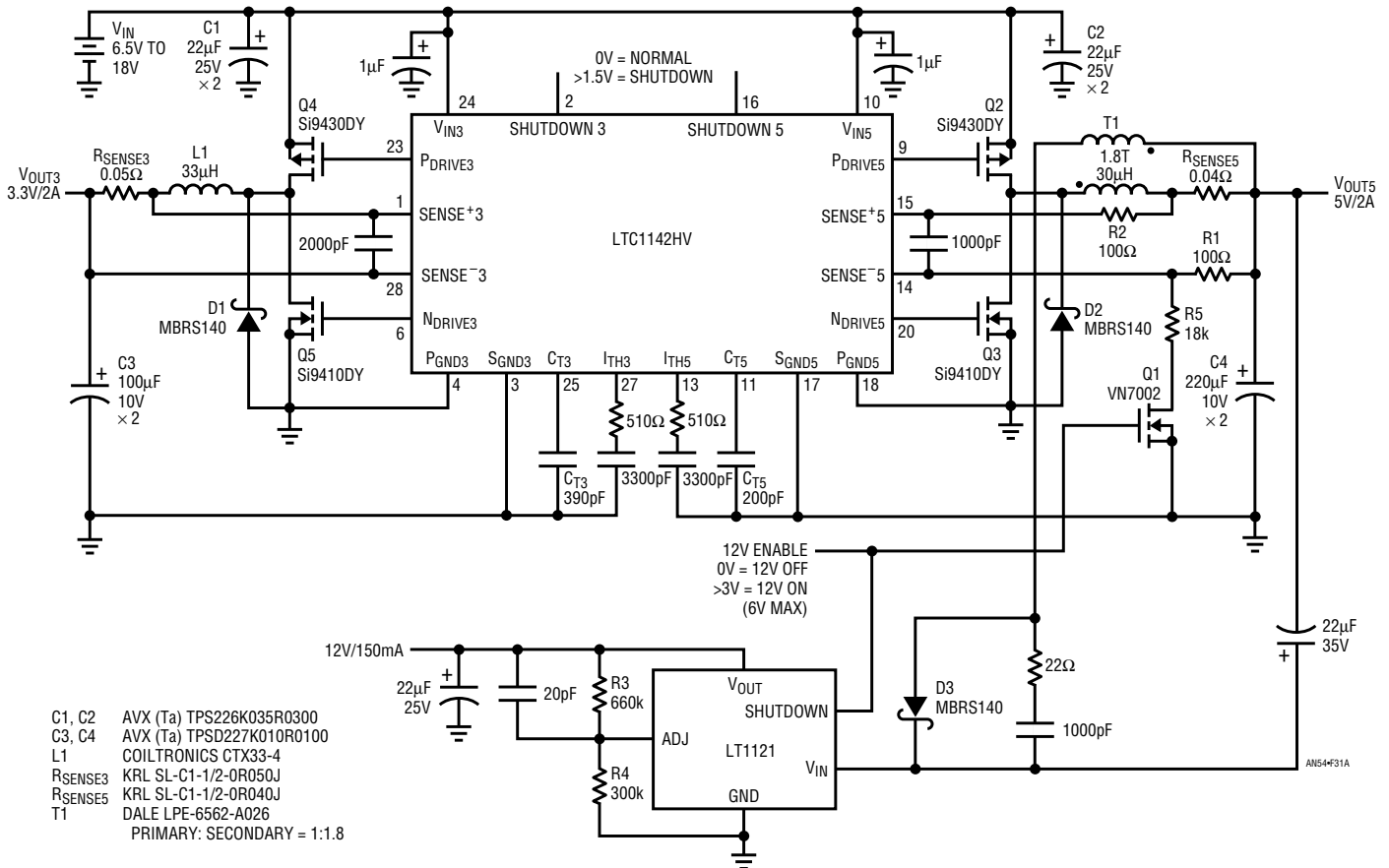

Figure 31A. LTC1142HV: (6.5V-18V to 3.3V/2A, 5V/2A, 12V/0.15A) High Voltage Triple Output Buck Converter

LTC1148: High Efficiency Charger Circuit

The LTC1148 regulator can be used as a highly efficient battery charging device. Figure 32 shows a circuit that is programmable for 1.3A fast charge or 100mA trickle charge mode. During the fast charge interval, the resistor divider network (R4 and R5) forces the LTC1148 feedback pin below 1.25V causing the regulator to operate at the maximum output current. Sense resistor R3 controls the current at approximately 1.3A. When the batteries are disconnected, the error amplifier sets the output voltage to be 8.1V (for proper operation this voltage should exceed

maximum possible voltage across the battery pack). Diode D2 prevents the batteries from discharging through the divider network when the charger is shut down.

Dual rate charging is controlled by Q3 which selects between fast and trickle charge. When the transistor turns on, R1 limits error amplifier output so that the current limiter starts operating at 100mA. If the trickle charge current needs to be altered, adjust R1. With 1.3A output current, this charger is capable of efficiency in excess of 90% which minimizes power dissipated in surface mount components.

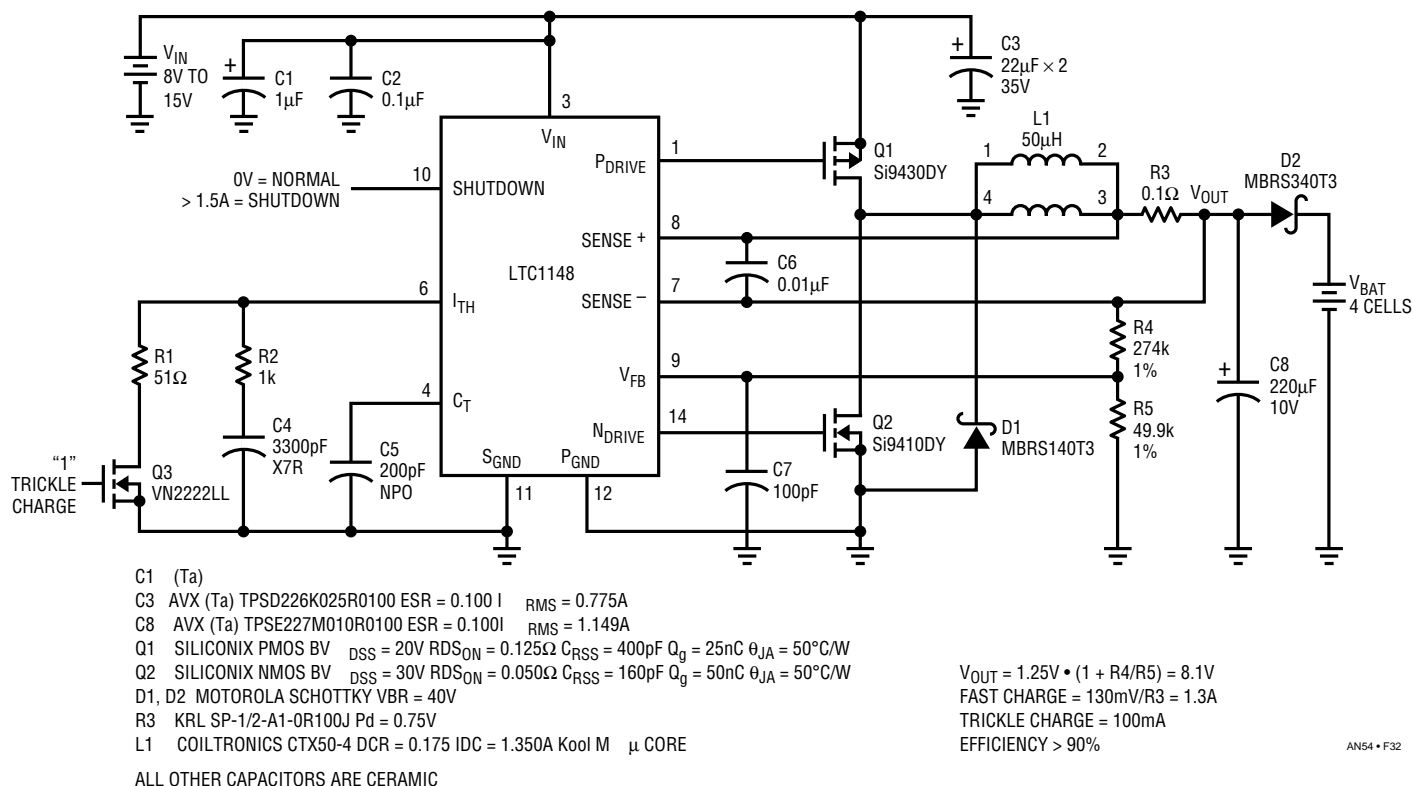

Figure 32. LTC1148: High Efficiency Charger Circuit

Application Note 54

LTC1148: High Voltage Charger Circuit

Figure 33 is a variation of Figure 32. It is designed to charge 6 cells and uses the LTC1148HV for higher input voltages. R4 value has been changed to provide 12.3V output when the battery is not connected.

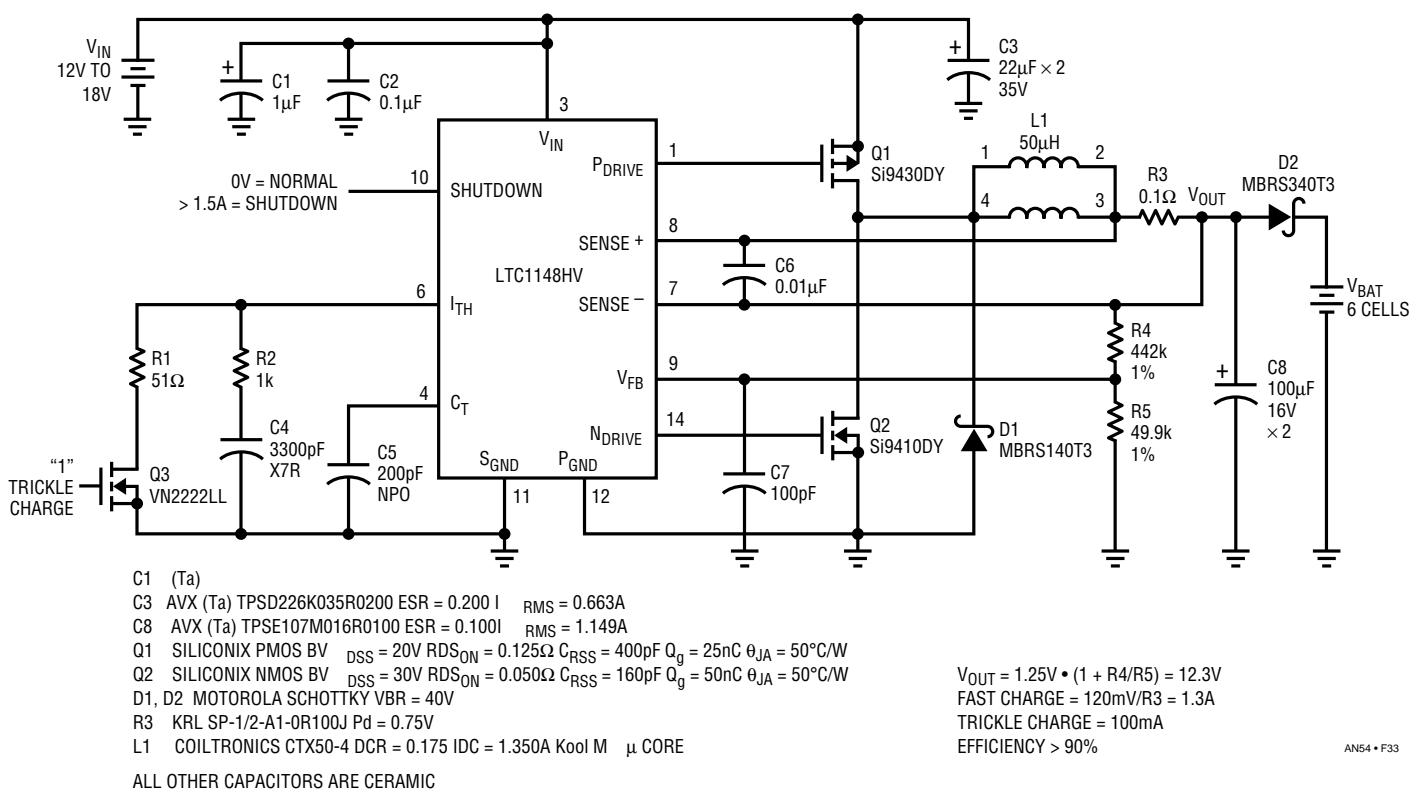

Figure 33. LTC1148: High Voltage Charger Circuit

LTC1142A: High Efficiency Power Supply Providing 3.3V/2A with Built-In Battery Charger

Figure 34 implements a high efficiency step-down converter with a built-in battery charger using a single IC. One section of the dual LTC1142A is used to convert 4-cells to

3.3V/2A in a regular buck configuration. The other section is configured in the same way as the battery charger from Figure 32. It is powered from a wall adapter and provides the battery with fast or trickle charging rate. When the adapter is not connected, D3 prevents the battery from discharging through the R2/R1 divider network.

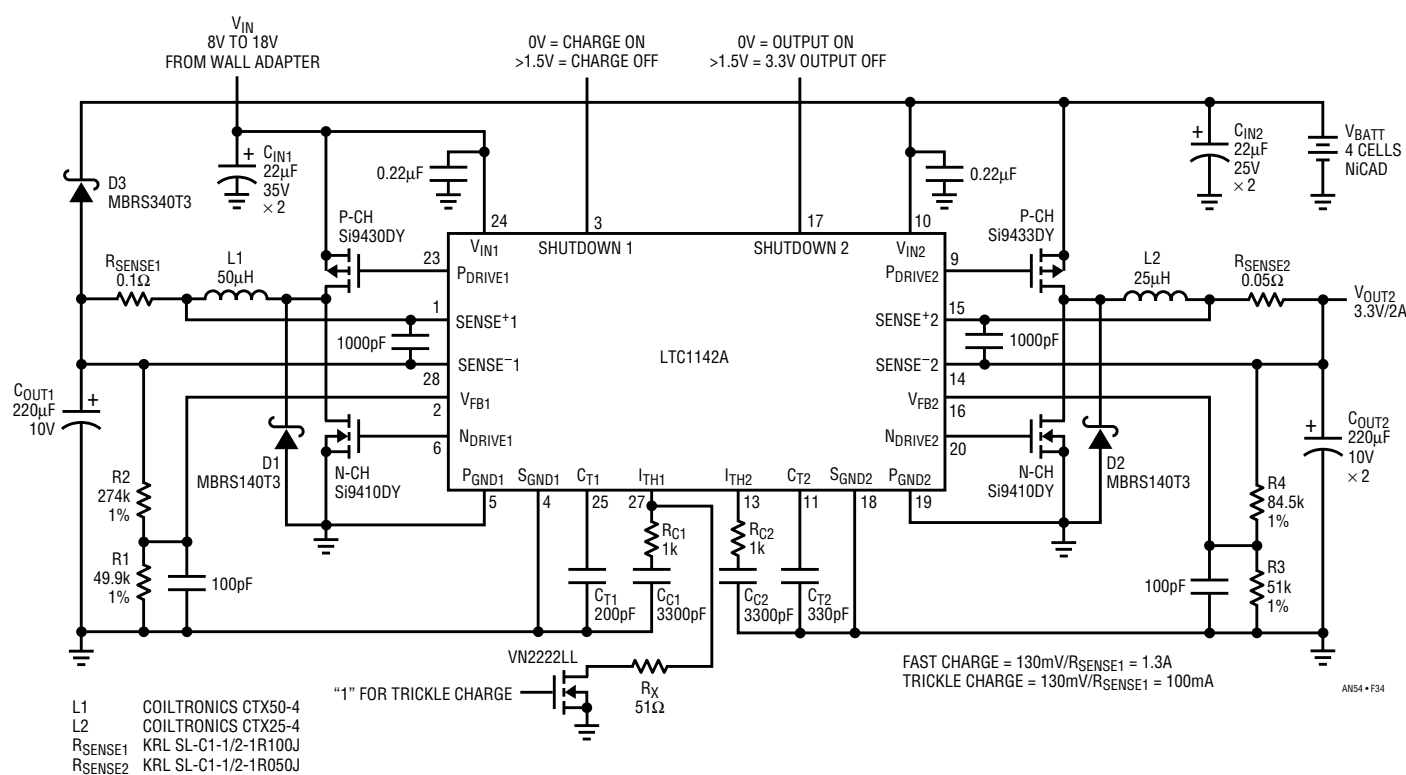

Figure 34. LTC1142A: High Efficiency Power Supply Providing 3.3V/2A with Built-In Battery Charger

Application Note 54

LTC1149: Dual Output Buck Converter

The circuit shown in Figure 35A implements the most elegant approach for dual output regulators that provide 3.3V and 5V outputs. It uses a *single* LTC1149. The synchronous rectification feature of this chip is used to provide excellent efficiency, as well as good cross regulation between the two outputs. Maximum output power of the converter is 17W, which may be drawn in any combination between 3.3V and 5V outputs.

A regular buck regulator is used for producing 3.3V output with T1's primary in place of the buck inductor. The secondary of T1 forms a boost winding for 5V output. The transformer is wound with a simple trifilar winding to ensure that the primary is closely coupled to the secondary. Superior cross regulation is achieved by the close primary-to-secondary coupling and by splitting voltage feedback paths (resistors R1 and R2 provide feedback signals from both 3.3V and 5V outputs). Diodes D1, D2 and capacitor C7 comprise a soft-start circuit that causes the output voltage to increase slowly when the power is first applied to the circuit. This circuit prevents overshoot

at the 3.3V output. The transformer used in this example is a standard product (see the parts list). A circuit board has been laid out for this circuit and has subsequently been thoroughly tested under full operating conditions and optimized for mass production requirements. A Gerber file for the board is available upon request.

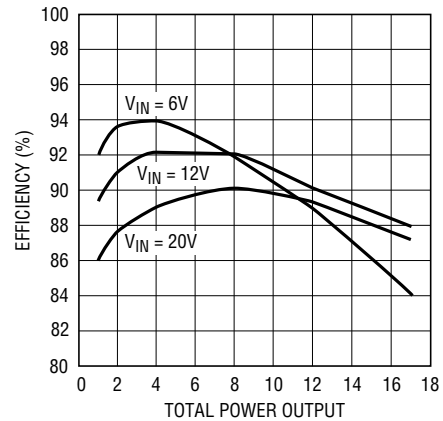
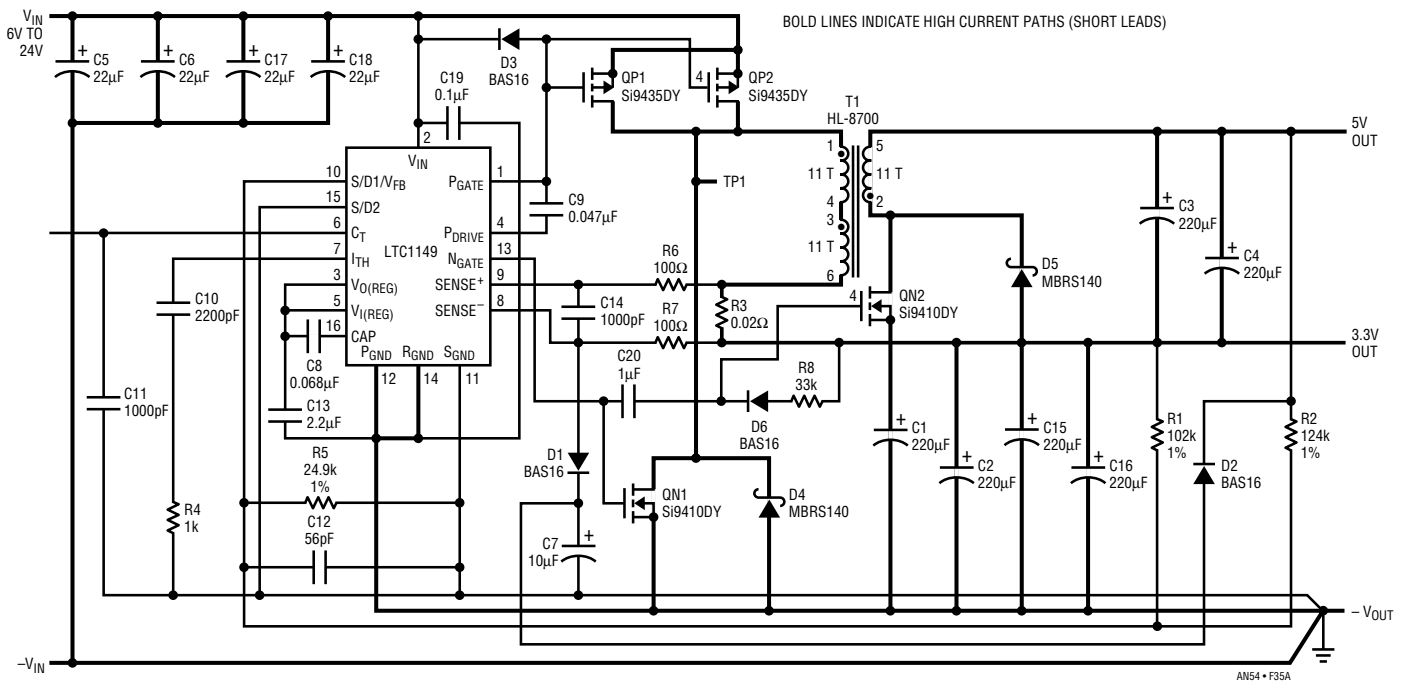

Figure 35B. LTC1149: Dual Output Buck Converter Measured Efficiency



- C3, C4, C15, C16 AVX (Ta) TPSE227M010R 498BCPA
- C5, C6, C8, C17 AVX (Ta) TPSE226M035R 498BCPA
- R3 IRC LR512-01-R020F
- T1 HURRICANE, HL-8700

Figure 35A. Single LTC1149: Dual Output Buck Converter

LTC1148: Constant Frequency Buck Converters

Finally, Figures 36A and 37A show circuits that completely satisfy the demand in ultra-high efficiency converters operating synchronously with an external clock. The rising edge of the clock saturates Q3 pulling pin 4 below the internal comparator threshold. The internal logic assumes the end of the off-time, and turns Q1 on. Now the LTC1148 operates as a conventional constant frequency current mode controller and therefore requires slope compensation. Q2 generates an artificial ramp signal that is superimposed on the inductor current waveform sensed by the shunt R7. This is a standard technique to eliminate subharmonic oscillation, a phenomenon that occurs under simultaneous conditions of fixed frequency and fixed amplitude of inductor current when the duty cycle exceeds 50%. Subharmonic oscillations are not related to the closed-loop transfer function.

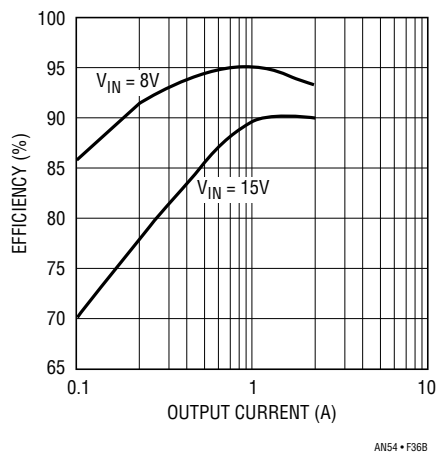

Figure 36B. LTC1148: (8V-15V to 5V/2A) Constant Frequency Buck Converter Measured Efficiency

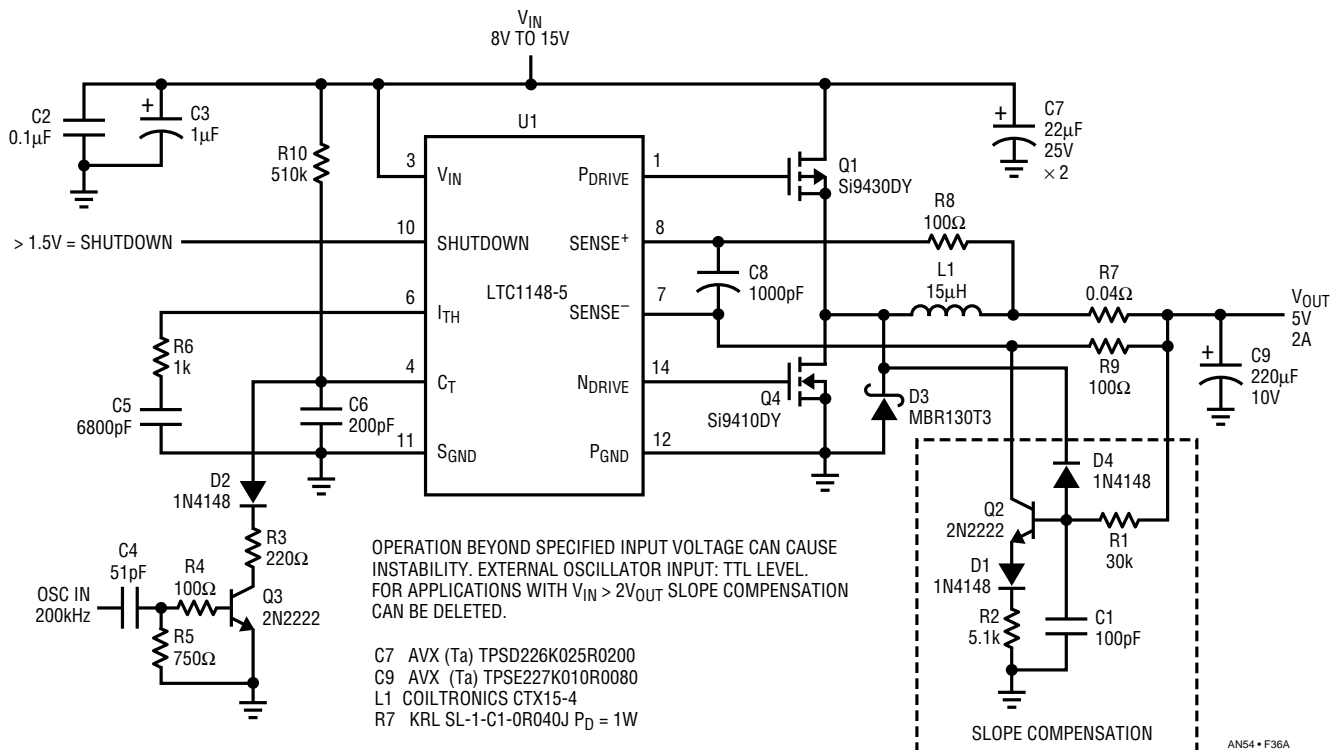

Figure 36A. LTC1148: (8V-15V to 5V/2A) Constant Frequency Buck Converter

Application Note 54

If the input voltage always exceeds twice the output (duty cycle in this case would be less than 50%) the circuit inside the dashed box can be omitted. Resistor R11 is added to the circuit to disable Burst Mode operation ensuring true in-sync operation over the full range of output current. The circuitry is designed to be synchronized by a 200kHz clock to accommodate other external frequencies; nothing more than component value changes is required. If the input voltage goes beyond specified range, the controller will lose synchronization (it will still regulate, however). R10 increases input voltage pull-in range and can be omitted if it is not required. Values above 430k ensure proper start-up.

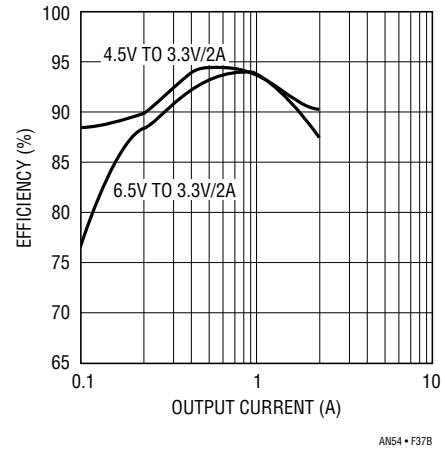

Figure 37B. LTC1148: (4.5V-6.5V to 3.3V/2A) Constant Frequency Buck Converter Measured Efficiency

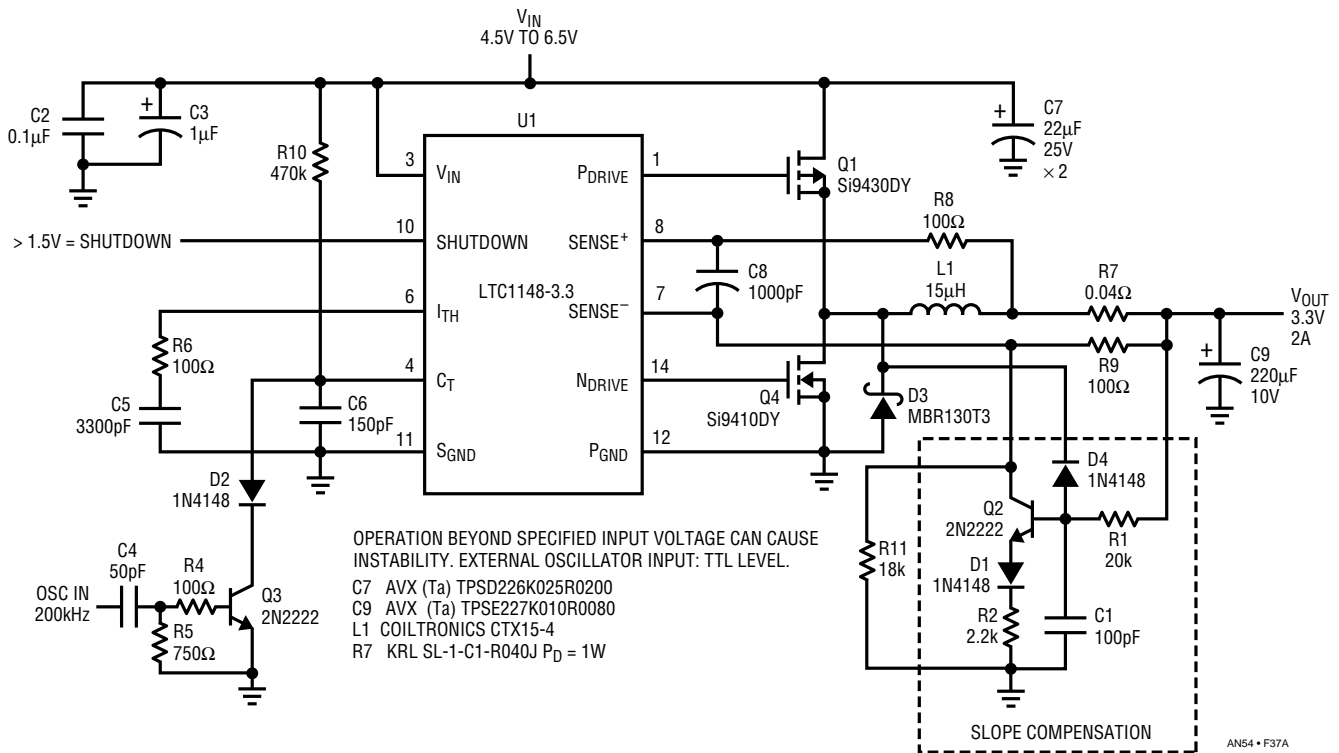

Figure 37A. LTC1148: (4.5V-6.5V to 3.3V/2A) Constant Frequency Buck Converter

APPENDIX A

TOPICS OF COMMON INTEREST

Defeating Burst Mode Operation

Sometimes applications require Burst Mode operation to be defeated. It might be useful in a high output current circuit which never operates at light loads. Ensuring continuous operation in this case usually improves the circuit noise immunity and helps to eliminate audible noise from certain types of inductors when they are lighter loaded. The Burst Mode operation should be disabled if an overwinding is used to provide boosted voltage, additional to the main output (for example, see Figure 30A). This allows to draw power from the secondary with improved cross-regulation, even if the primary output is not loaded. Defeating of Burst Mode operation should also be considered when the fixed frequency circuits from Figures 36A and 37A are used. With continuous operation these circuits always operate fully synchronized to the external clock.

Whatever the reason, Burst Mode operation can be suppressed with a simple external network which cancels the 25mV minimum current comparator threshold. An external offset is put in series with the SENSE⁻ pin to subtract from the built-in 25mV offset. An example of this technique is shown in Figure A1.

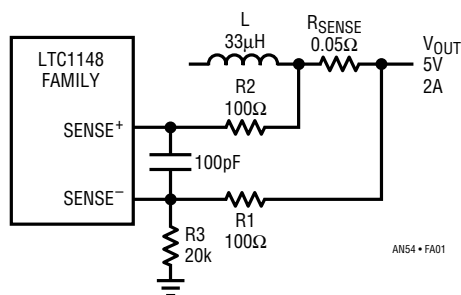

Figure A1. Defeating Burst Mode

Two 100Ω resistors are inserted in series with the leads from the sense resistor. With the addition of R3, a current is generated through R1 causing an offset of:

$$V_{\text{OFFSET}} = V_{\text{OUT}} \times \left(\frac{R1}{R1 + R3} \right)$$

If V_{OFFSET} exceeds 25mV the minimum threshold will be cancelled and Burst Mode operation is prevented from occurring. Since the offset voltage is constant, the maximum load current is also decreased. Thus to get back to the same output current, the sense resistor must be lower:

$$R_{\text{SENSE}} = \frac{75\text{mV}}{I_{\text{MAX}}}$$

Soft-Start Circuits

Right after the power-on, the regulator operates in a short-circuit condition while charging output capacitors. With earlier voltage mode converters, this led to enormous current transient at start-up. Soft-start circuits were usually added to fix this problem. The LTC1148 series implements current mode technique which inherently provides current limiting and does not require any special soft-start circuits. Start-up current is limited to the short-circuit current value of $150\text{mV}/R_{\text{SENSE}}$.

Some applications might, however, require softer start. It helps to avoid output overshoot when the power is first applied to the circuit, and it also prevents the input supply's overcurrent protection from latching, when the input voltage increases slowly. Figures A2 and A3 provide possible solutions for soft-start. Capacitor C1 in Figure A2 holds down I_{TH} pin limiting the output current. C1 is charged via R1, when the voltage across its terminals exceeds DC level of I_{TH} pin, D2 becomes reverse-biased and the capacitor no longer has an effect on the circuit operation. D1 provides discharge path for C1 when the input voltage is removed. The soft-start time constant is defined by R1 and C1.

In Figure A3, capacitor C1 holds down the SENSE⁻ pin providing additional offset to the current comparator. C1 charges through D1 and R2, slowly increasing maximum operating current. When C1 is fully charged D1 is reverse-biased and the capacitor no longer affects the operation.

Application Note 54

D2 provides a discharge path for C1 when the output voltage disappears. The soft-start time constant is defined by R2 and C1.

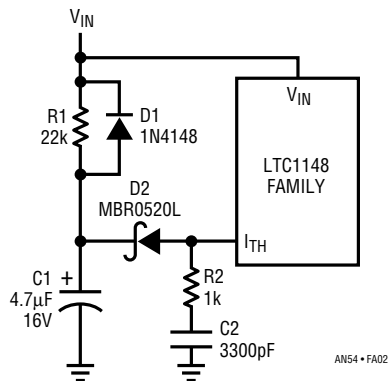

Figure A2. Soft-Start Circuit with I_{TH} Pin Clamping

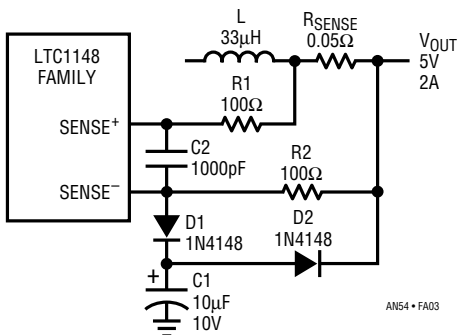

Figure A3. Soft-Start Circuit with Sense Pin Clamping

The simplest approach uses load step transient by switching in an additional load resistor and simultaneously monitoring the output. Switching regulators take several cycles to respond to a step in resistive load current. When a load step occurs, output voltage shifts by an amount equal to $\Delta I_{LOAD} \times ESR$, where ESR is the output capacitor effective series resistance. Load current change also begins to charge or discharge output capacitor until the regulator loop adapts to the current change and returns V_{OUT} to its steady state value. If during this recovery time V_{OUT} has ringing, it indicates a stability problem, and the capacitor at I_{TH} pin should be increased.

A simple dynamic load circuit is shown in Figure A4 where the MOSFET Q1, driven by an external generator, switches a load resistor R2 in and out. The generator should provide 10V gate drive (not a TTL level). The drive signal frequency is not critical. A good starting point is 500Hz and the load change from 50% to the full load.

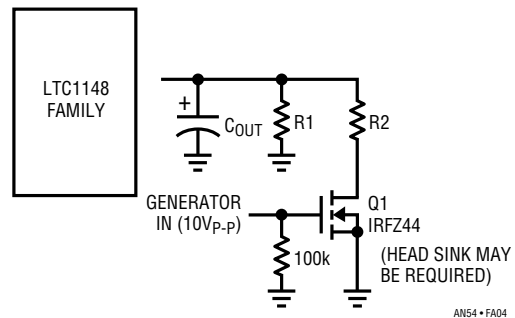

Figure A4. Simple Dynamic Load

Frequency Compensation

The LTC1148 family of regulators contains both voltage and current loops, which, together with external capacitors and inductors, require a pretty complex mathematical approach to frequency compensation. Operating point changes with input voltage and output current variations add complications and suggest a more practical empirical method.

The LTC1148 series regulators provide a very stable operation. The compensation values used in the circuits in this note have been tested over the wide range of operating conditions and proved to provide an adequate compensation for most applications. Usually no stability testing, as described above, is required.

APPENDIX B

SUGGESTED MANUFACTURERS

Linear Technology provides this list of manufacturers to get you started in your component selection process. We make no claims about any of these companies except that they provide components necessary in switching power supplies. There are many more companies to choose from; for a more complete list refer to the PCIM Buyer's

Guide. PCIM (Power Conversion & Intelligent Motion) is published by Intertec International Inc., 2472 Eastman Ave., Bldg. 33-34, Ventura, California 93003-5774, (805) 650-7070. PCIM is free to qualified applicants. Back issues, such as the Buyer's Guide can be purchased.

Batteries

Duracell
OEM Sales & Marketing
Berkshire Industrial Park
Bethel, CT 06801
(800) 431-2656

Eveready Battery Co.
Checkerboard Square
St. Louis, MO 63164
(314) 982-2000

Bipolar Transistors

Motorola Inc.
3102 North 56th St.
MS 56-126
Phoenix, AZ 85018
(800) 521-6274
Full Line

Zetex
87 Modular Ave.
Commack, NY 11725
(516) 543-7100
High Gain Bipolar Switching Transistors
including Surface Mount Devices

Capacitors

AVX Corporation
P.O. Box 867
Myrtle Beach, SC 29578
(803) 946-0690
Tant., Cer., Surface Mount

Elpac
1567 Reynolds Ave.
Irvine, CA 92714
Film Capacitors
(714) 476-6070
Film Capacitors

Intertechnical Group
2269 Saw Mill River Rd., Bldg. 4C
P.O. Box 217
Elmsford, NY 10523
(914) 347-2474
Polycarbonate Film

Philips Components
1440 W. Indian Town Rd.
Jupiter, FL 33458
(407) 744-4200
Cer., Chip Capacitors

Murata Erie North America
1900 W. College Ave.
State College, PA 16801
(814) 237-1431

Nichicon (America) Corporation
927 East State Parkway
Schaumburg, IL 60173
(708) 843-7500
Aluminum Electrolytic

Sanyo Video Components (USA) Corp.
2001 Sanyo Ave.
San Diego, CA 92173
(619) 661-6835
Low ESR Filter Capacitors-Solid Aluminum
Electrolytic Capacitors (OS-CON)

Sprague
678 Main St.
P.O. Box 231
Sanford, ME 04073
(207) 324-4140
Tantalum Capacitors

Current Sense Resistors

Dale Electronics
1122 23rd St.
P.O.Box 609
Columbus, NE 68602
(402) 564-3131
Resistors, Inductors, Xformers

IRC
4222 South Staples St.
Corpus Christi, TX 78411
(512) 992-7900

KRL
160 Bouchard St.
Manchester, NH 03103
(603) 668-3210

Diodes

Fuji/Collmer
14368 Proton Rd.
Dallas, TX 75244
(214) 233-1589
Low Current Schottkys

General Instruments
10 Melville Park Rd.
Melville, NY 11747
(516) 847-3222

Motorola Inc.
5005 E. McDowell Rd.
P.O. Box 2953
Phoenix, AZ 85062
(602) 244-5768
Diodes

Philips Components Disc. Prod. Div.
100 Providence Pike
Slatersville, RI 02876
(401) 762-3800
Discrete Semi Group

Ferrite Beads

Fair-Rite Products Corp.
1 Commercial Row
P.O. Box J
Wallkill, NY 12589
(914) 895-2055

Toshiba America Elec. Components
9775 Toledo Way
Irvine, CA 92718
(714) 455-2000

Heat Sinks

Aavid Engineering, Inc.
One Kool Path Box 400
Laconia, NH 03247
(603) 528-3400

Int'l Electronic Research Group
135 W. Magnolia Blvd.
Burbank, CA 91502
(213) 849-2481

Application Note 54

Thermalloy
2021 W. Valley View Lane
Dallas, TX 75234
(214) 243-4321

Inductors and Transformers

Beckman Industrial Corp.
4200 Bonita Place
Fullerton, CA 92635
(714) 447-2345
Inductors, Xformers including SMT

Caddell-Burns
258 East Second St.
Mineola, NY 11501
(516) 746-2310

Coilcraft
1102 Silver Lake Rd.
Cary, IL 60013
(800) 322-2645

Coiltronics
6000 Park of Commerce Blvd.
Boca Raton, FL 33487
(407) 241-7876
Full Line including Surface Mount Inductors

Dale Electronics
E. Highway 50
P. O. Box 180
Yankton, SD 57078
(605) 665-9301
Inductors, Xformers including SMT

Gowanda Electronics Corp.
1 Industrial Place
Gowanda, NY 14070
(716) 532-2234

Hurricane Electronics Lab
P.O. Box 1280
Hurricane, UT 84737
(801) 635-2003

Murata Erie North America
2200 Lake Park Drive
Smyrna, GA 30080
(404) 436-1300

Renco
60 E. Jefryn Blvd.
Deerpark, NY 11729
(516) 586-5566

Sumida Electronic
5999 New Wilke Rd., Ste. 110
Rolling Meadows, IL 60008
(708) 956-0666

TDK Corp. of America
1600 Feehanville Dr.
Mount Prospect, IL 60056
(708) 803-6100

Toko America Incorporated
1250 Feehanville Dr.
Mount Prospect, IL 60056
(708) 635-3200

Magnetic Materials

Fair-Rite Products Corp.
1 Commercial Row
P. O. Box J
Wallkill, NY 12589
(914) 895-2055
Ferrite

Micrometals, Inc.
1190 N. Hawk Circle
Anaheim, CA 92807
(800) 356-5977
Powdered Iron

Magnetics Div. Spang & Co
P.O. Box 391
Butler, PA 16003-0391
(412) 282-8282
Molypermalloy, Kool M μ , Ferrite

Philips Components Disc. Prod. Div.
Materials Group
1033 King Highway
Saugerties, NY 12477
(914) 246-2811
Ferrite

Pyroferic International, Inc.
200 Madison St.
Toledo, IL 62468
(217) 849-3300
Powdered Iron

Siemens Components, Inc.
186 Wood Ave. South
Iselin, NJ 08830
(908) 906-4300
Ferrite

TDK Corp. of America
1600 Feehanville Dr.
Mount Prospect, IL 60056
(708) 803-6100
Ferrite

Mounting Hardware

Bergquist
5300 Edina Industrial Blvd.
Minneapolis, MN 55439
(612) 835-2322
Thermally Conductive Insulators

Stockwell Rubber
4749 Tolbut St.
Philadelphia, PA 19136
(800) 523-0123
Thermally Conductive Insulators

Thermalloy
2021 W. Valley View Lane
Dallas, TX 75234
(214) 243-4321
Power Sockets, Thermal Compounds,
and Adhesives Thermally Conductive
Insulators, Mounting Kits

Power MOSFETs

International Rectifier Corp.
233 Kansas St.
El Segundo, CA 90245
(310) 322-3331

Motorola Inc.
5005 E. McDowell Rd.
Phoenix, AZ 85008
(602) 244-3576

Siliconix
2201 Laurelwood Rd.
Santa Clara, CA 96056
(800) 554-5565

Resistors

Micro-Ohm Corp.
1088 Hamilton Rd.
Duarte, CA 91010
(818) 357-5377

Thermo Disc
1981 Port City Blvd.
Muskegon, MI 49443
(616) 777-2602

RCD Components, Inc.
520 East Industrial Park Dr.
Manchester, NH 03109
(603) 669-0054

Caddock Electronics
1717 Chicago Ave.
Riverside, CA 92507-2364
(909) 788-1700

Wire

Belden Wire & Cable
P.O. BOX 1980
Richmond, IN 47375
(317) 983-5200