



LT138A/LT338A
LM138/LM338

5A Positive Adjustable Voltage Regulator

FEATURES

- *Guaranteed* 1% Initial Tolerance
- *Guaranteed* 0.3% Load Regulation
- *Guaranteed* 5A Output Current
- 100% Thermal Limit Burn-In
- 12A Transient Output Current
- Available in 3-Lead Plastic TO-3P Package

APPLICATIONS

- High Power Linear Regulator
- Battery Chargers
- Power Driver
- Constant-Current Regulator

DESCRIPTION

The LT[®]138A series of adjustable regulators provide 5A output current over an output voltage range of 1.2V to 32V. The internal voltage reference is trimmed to less than 1%, enabling a very tight output voltage. In addition to excellent line and load regulation, with full overload protection, the LT138A incorporates new current limiting circuitry allowing large transient load currents to be handled for short periods. Transient load currents of up to 12A can be supplied without limiting, eliminating the need for a large output capacitor.

The LT138A is an improved version of the popular LM138 with improved circuit design and advanced process techniques to provide superior performance and reliability.

The graph below shows the significant improvement in output voltage tolerance achieved by using the LT138A or LT338A.

LT, LTC and LT are registered trademarks of Linear Technology Corporation. All other trademarks are the property of their respective owners.

TYPICAL APPLICATION

Parallel Regulators for Higher Current*

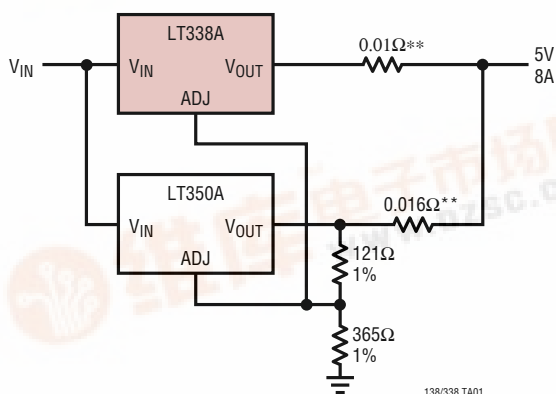

138/338 TA01

Output Voltage Error

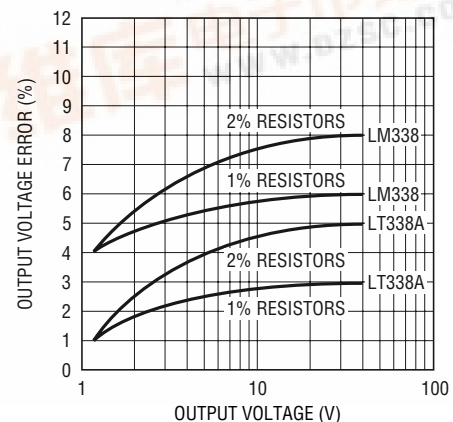

138A/338A TA02

*THIS CIRCUIT WILL NOT WORK WITH LM VERSION DEVICES
**CURRENT SHARING RESISTORS DEGRADE REGULATION TO 1%

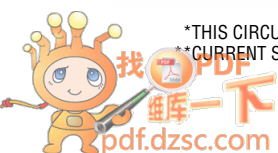

LT138A/LT338A LM138/LM338

ABSOLUTE MAXIMUM RATINGS (Note 1)

Power Dissipation Internally Limited
 Input-to-Output Voltage Differential 35V
 Operating Junction Temperature Range
 LT138A/LM138 -55°C to 150°C
 LT338A/LM338 0°C to 125°C

Storage Temperature Range -65°C to 150°C
 Lead Temperature (Soldering, 10 sec) 300°C

PRECONDITIONING

100% Thermal Limit Burn-In

PACKAGE/ORDER INFORMATION

<p>OBSELETE PACKAGE Consider the P Package for Alternate Source</p>	ORDER PART NUMBER LT138AK LT338AK LM138K LM338K		ORDER PART NUMBER LM338P

Consult LTC Marketing for parts specified with wider operating temperature ranges.

ELECTRICAL CHARACTERISTICS

The ● denotes the specifications which apply over the full operating temperature range, otherwise specifications are at $T_A = 25^\circ\text{C}$. (Note 2)

SYMBOL	PARAMETER	CONDITIONS	LT138A			LM138			UNITS
			MIN	TYP	MAX	MIN	TYP	MAX	
V_{REF}	Reference Voltage	$I_{OUT} = 10\text{mA}$, $T_J = 25^\circ\text{C}$	1.238	1.250	1.262				V
		$3\text{V} \leq (V_{IN} - V_{OUT}) \leq 35\text{V}$, $10\text{mA} \leq I_{OUT} \leq 5\text{A}$, $P \leq 50\text{W}$	● 1.225	1.250	1.270	1.19	1.24	1.29	V
$\frac{\Delta V_{OUT}}{\Delta V_{IN}}$	Line Regulation	$3\text{V} \leq (V_{IN} - V_{OUT}) \leq 35\text{V}$, (Note 3)		0.005	0.01	0.005	0.01	%/V	
		●	0.02	0.04	0.02	0.04	%/V		
$\frac{\Delta V_{OUT}}{\Delta I_{OUT}}$	Load Regulation	$10\text{mA} \leq I_{OUT} \leq 5\text{A}$, (Note 3)							
		$V_{OUT} \leq 5\text{V}$		5	15	5	15	mV	
		$V_{OUT} \geq 5\text{V}$		0.1	0.3	0.1	0.3	%	
		$V_{OUT} \leq 5\text{V}$	●	20	30	20	30	mV	
		$V_{OUT} \geq 5\text{V}$	●	0.3	0.6	0.3	0.6	%	
	Thermal Regulation	20ms Pulse		0.002	0.01	0.002	0.01	%/W	
	Ripple Rejection	$V_{OUT} = 10\text{V}$, $f = 120\text{Hz}$ $C_{ADJ} = 0\mu\text{F}$ $C_{ADJ} = 10\mu\text{F}$	●	60	60	60	60	dB	
		●	60	75	60	75	dB		
I_{ADJ}	Adjust Pin Current		●	45	100	45	100	μA	
ΔI_{ADJ}	Adjust Pin Current Change	$10\text{mA} \leq I_{OUT} \leq 5\text{A}$, $3\text{V} \leq (V_{IN} - V_{OUT}) \leq 35\text{V}$	●	0.2	5	0.2	5	μA	
	Minimum Load Current	$(V_{IN} - V_{OUT}) = 35\text{V}$	●	3.5	5	3.5	5	mA	

LT138A/LT338A LM138/LM338

ELECTRICAL CHARACTERISTICS

The ● denotes the specifications which apply over the full operating temperature range, otherwise specifications are at $T_A = 25^\circ\text{C}$. (Note 2)

SYMBOL	PARAMETER	CONDITIONS	LT138A			LM138			UNITS
			MIN	TYP	MAX	MIN	TYP	MAX	
I_{SC}	Current Limit	$(V_{IN} - V_{OUT}) \leq 10\text{V}$ DC 0.5ms Peak	●	5	8				A
			●	6	12				A
		$(V_{IN} - V_{OUT}) = 30\text{V}, T_J = 25^\circ\text{C}$			1	2		1	A
$\frac{\Delta V_{OUT}}{\Delta \text{Temp}}$	Temperature Stability			1	2		1	%	
$\frac{\Delta V_{OUT}}{\Delta \text{Time}}$	Long-Term Stability	$T_A = 125^\circ\text{C}, 1000$ Hours		0.3	1		0.3	1	%
e_n	RMS Output Noise (% of V_{OUT})	$10\text{Hz} \leq f \leq 10\text{kHz}$		0.001			0.003		%
θ_{JC}	Thermal Resistance Junction-to-Case	K Package			1		1	$^\circ\text{C}/\text{W}$	

The ● denotes the specifications which apply over the full operating temperature range, otherwise specifications are at $T_A = 25^\circ\text{C}$. (Note 2)

SYMBOL	PARAMETER	CONDITIONS	LT338A			LM338			UNITS
			MIN	TYP	MAX	MIN	TYP	MAX	
V_{REF}	Reference Voltage	$I_{OUT} = 10\text{mA}$		1.238	1.250	1.262			V
		$3\text{V} \leq (V_{IN} - V_{OUT}) \leq 35\text{V},$ $10\text{mA} \leq I_{OUT} \leq 5\text{A}, P \leq 50\text{W}$	●	1.225	1.250	1.270	1.19	1.24	1.29
$\frac{\Delta V_{OUT}}{\Delta V_{IN}}$	Line Regulation	$3\text{V} \leq (V_{IN} - V_{OUT}) \leq 35\text{V},$ (Note 3)		0.005	0.01		0.005	0.03	%/V %/V
$\frac{\Delta V_{OUT}}{\Delta I_{OUT}}$	Load Regulation	$10\text{mA} \leq I_{OUT} \leq 5\text{A},$ (Note 3) $V_{OUT} \leq 5\text{V}$ $V_{OUT} \geq 5\text{V}$		5	15		5	25	mV %
				0.1	0.3		0.1	0.5	
		$V_{OUT} \leq 5\text{V}$ $V_{OUT} \geq 5\text{V}$	● ●	20 0.3	30 0.6		20 0.3	50 1	mV %
	Thermal Regulation	20ms Pulse		0.002	0.02		0.002	0.02	%/W
	Ripple Rejection	$V_{OUT} = 10\text{V}, f = 120\text{Hz}$ $C_{ADJ} = 0\mu\text{F}$ $C_{ADJ} = 10\mu\text{F}$	● ●	60	60 75		60	60 75	dB dB
I_{ADJ}	Adjust Pin Current		●	45	100		45	100	μA
ΔI_{ADJ}	Adjust Pin Current Change	$10\text{mA} \leq I_{OUT} \leq 5\text{A},$ $3\text{V} \leq (V_{IN} - V_{OUT}) \leq 35\text{V}$	●	0.2	5		0.2	5	μA
	Minimum Load Current	$(V_{IN} - V_{OUT}) = 35\text{V}$	●	3.5	10		3.5	10	mA
I_{SC}	Current Limit	$(V_{IN} - V_{OUT}) \leq 10\text{V}$ DC 0.5ms Peak	●	5	8		5	8	A
			●	6	12		6	12	A
		$(V_{IN} - V_{OUT}) = 30\text{V}, T_J = 25^\circ\text{C}$			1	2		1	A
$\frac{\Delta V_{OUT}}{\Delta \text{Temp}}$	Temperature Stability			1	2		1	%	
$\frac{\Delta V_{OUT}}{\Delta \text{Time}}$	Long-Term Stability	$T_A = 125^\circ\text{C}, 1000$ Hours		0.3	1		0.3	1	%
e_n	RMS Output Noise (% of V_{OUT})	$10\text{Hz} \leq f \leq 10\text{kHz}$		0.001			0.003		%
θ_{JC}	Thermal Resistance Junction-to-Case	K Package			1		1	$^\circ\text{C}/\text{W}$	

Note 1: Absolute Maximum Ratings are those values beyond which the life of the device may be impaired.

Note 2: Unless otherwise specified, these specifications apply: $V_{IN} - V_{OUT} = 5\text{V}$ and $I_{OUT} = 2.5\text{A}$. These specifications are applicable for power dissipations up to 50W.

Note 3: See thermal regulation specifications for changes in output voltage due to heating effects. Load and line regulation are measured at a constant junction temperature by low duty cycle pulse testing.

LT138A/LT338A LM138/LM338

TYPICAL PERFORMANCE CHARACTERISTICS

Load Regulation

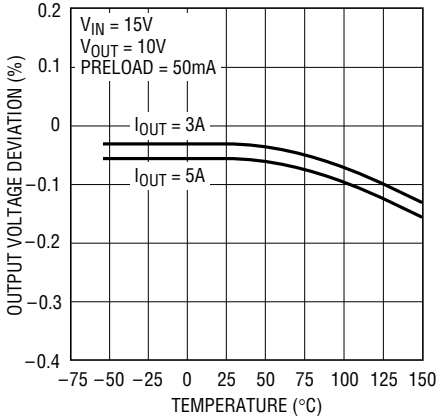

138/338 G01

Dropout Voltage

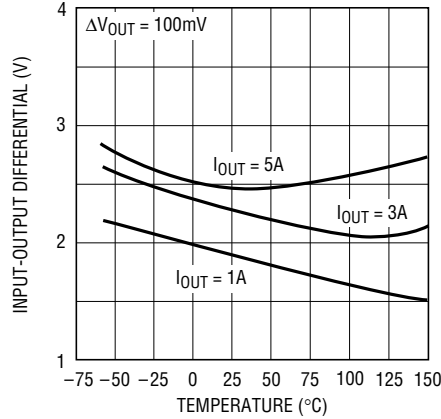

138/338 G02

Adjustment Current

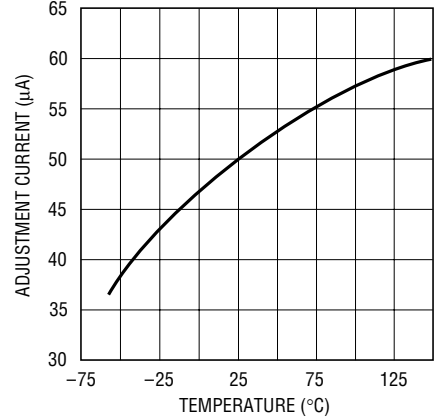

138A/338A G03

Temperature Stability

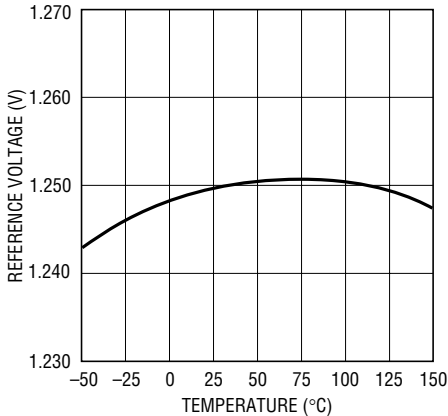

138A/338A G04

Output Impedance

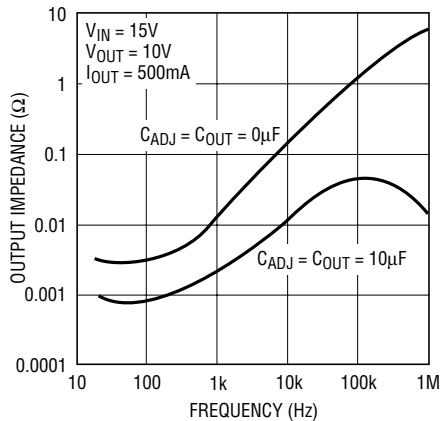

138/338 G05

Minimum Operating Current

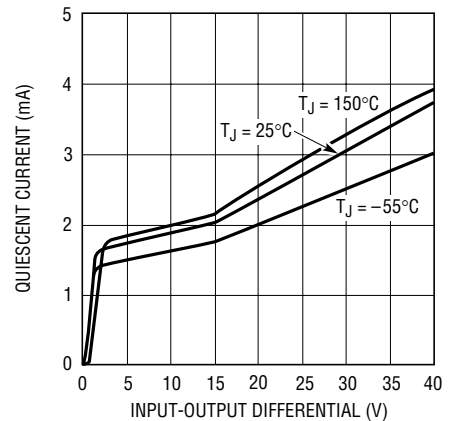

138A/338A G06

Ripple Rejection

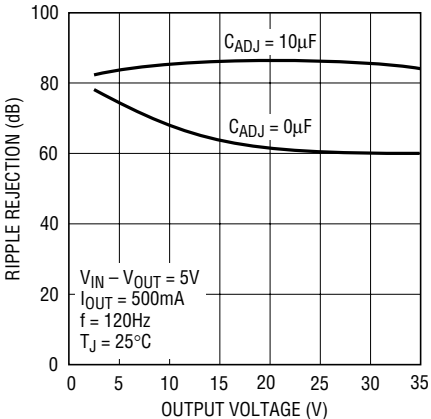

138A/338A G07

Ripple Rejection

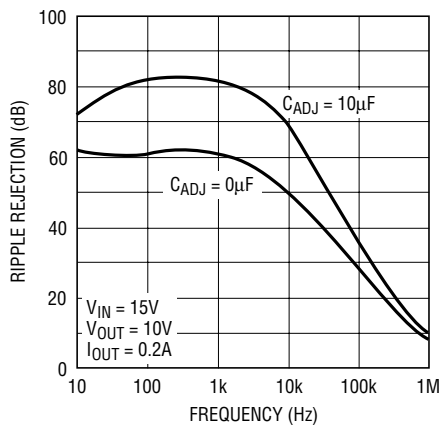

138A/338A G08

Ripple Rejection

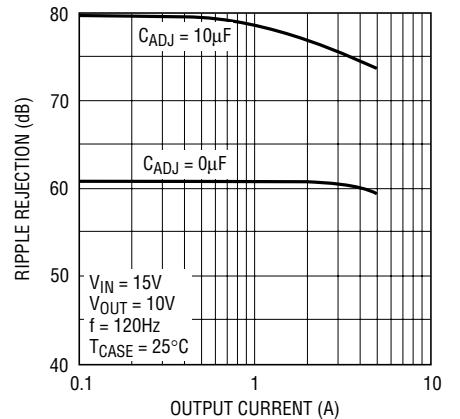

138/338 G09

TYPICAL PERFORMANCE CHARACTERISTICS

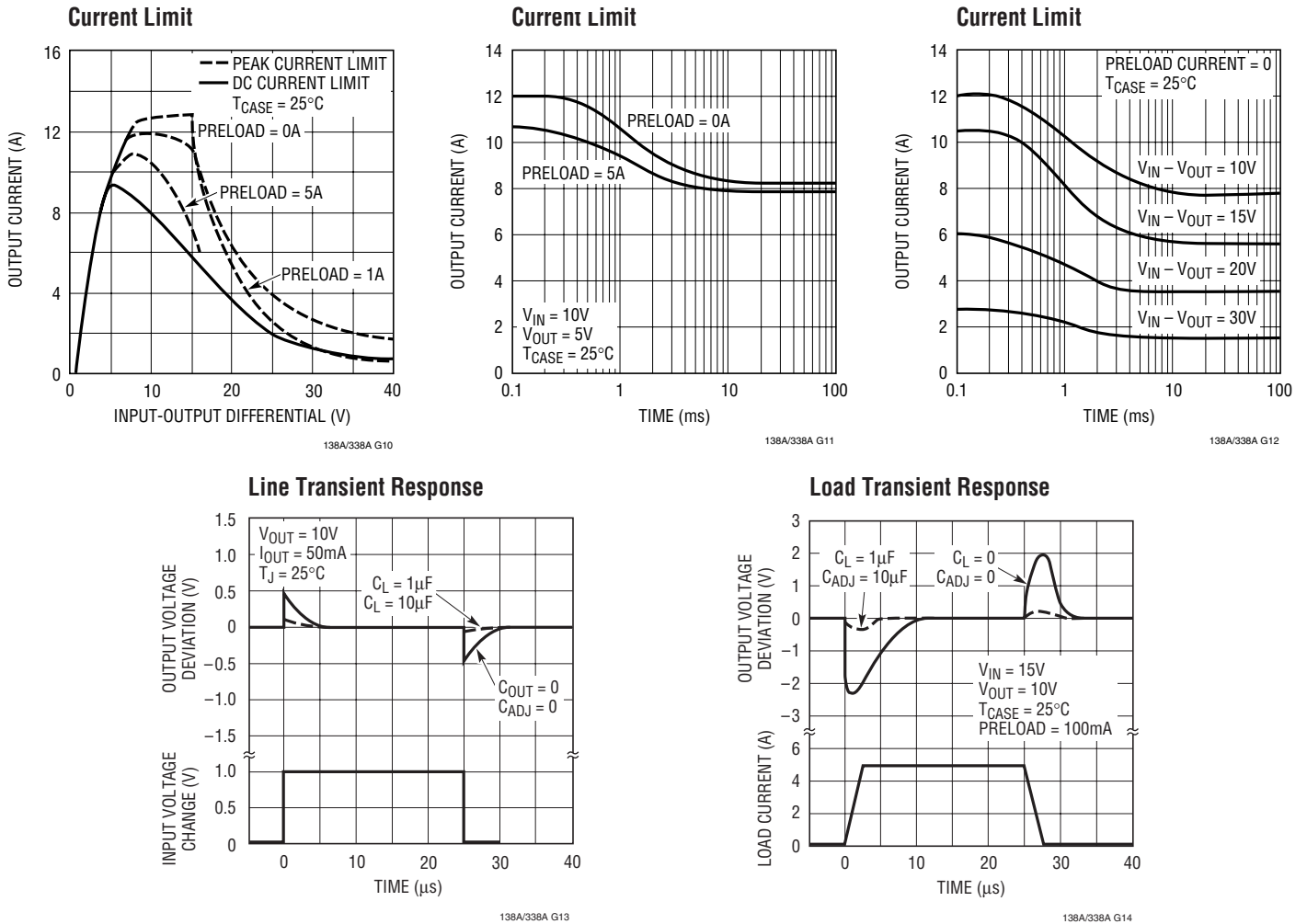

APPLICATIONS INFORMATION

General

The LT138A develops a 1.25V reference voltage between the output and the adjustable terminal (see Figure 1). By placing a resistor, R1, between these two terminals, a constant current is caused to flow through R1 and down through R2 to set the overall output voltage. Normally this current is the specified minimum load current of 5mA or 10mA. Because I_{ADJ} is very small and constant when compared with the current through R1, it represents a small error and can usually be ignored. It is easily seen from the output voltage equation, that even if the resistors were of exact value, the accuracy of the output is limited by the accuracy of V_{REF} . Earlier adjustable regulators had a reference

tolerance of $\pm 4\%$ which is dangerously close to the $\pm 5\%$ supply tolerance required in many logic and analog systems. Further, even 1% resistors can drift $0.01\%/^{\circ}C$, adding additional error to the output voltage tolerance.

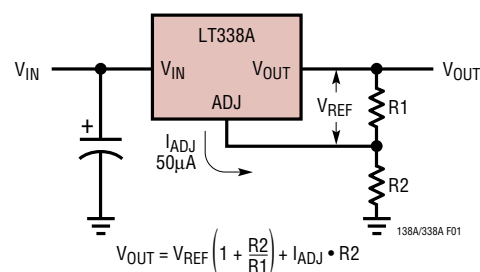

Figure 1. Basic Adjustable Regulator

LT138A/LT338A LM138/LM338

APPLICATIONS INFORMATION

For example, using 2% resistors and $\pm 4\%$ tolerance for V_{REF} , calculations will show that the expected range of a 5V regulator design would be $4.66V \leq V_{OUT} \leq 5.36V$ or approximately $\pm 7\%$. If the same example were used for a 15V regulator, the expected tolerance would be $\pm 8\%$. With these results most applications required some method of trimming, usually a trim pot. This solution is both expensive and not conducive to volume production.

One of the enhancements of Linear Technology's adjustable regulators over existing devices is the tightened initial tolerance of V_{REF} . This allows relatively inexpensive 1% or 2% film resistors to be used for R1 and R2 to set the output voltage within an acceptable tolerance.

With a guaranteed 1% reference, a 5V power supply design, using $\pm 2\%$ resistors, would have a worst-case manufacturing tolerance of $\pm 4\%$. If 1% resistors are used, the tolerance will drop to $\pm 2.5\%$. A plot of the worst-case output voltage tolerance as a function of resistor tolerance is shown on the front page of this data sheet.

For convenience, a table of standard 1% resistor values is shown in Table 1.

Table 1. 0.5% and 1% Standard Resistance Values

1.00	1.47	2.15	3.16	4.64	6.81
1.02	1.50	2.21	3.24	4.75	6.98
1.05	1.54	2.26	3.32	4.87	7.15
1.07	1.58	2.32	3.40	4.99	7.32
1.10	1.62	2.37	3.48	5.11	7.50
1.13	1.65	2.43	3.57	5.23	7.68
1.15	1.69	2.49	3.65	5.36	7.87
1.18	1.74	2.55	3.74	5.49	8.06
1.21	1.78	2.61	3.83	5.62	8.25
1.24	1.82	2.67	3.92	5.76	8.45
1.27	1.87	2.74	4.02	5.90	8.66
1.30	1.91	2.80	4.12	6.04	8.87
1.33	1.96	2.87	4.22	6.19	9.09
1.37	2.00	2.94	4.32	6.34	9.31
1.40	2.05	3.01	4.42	6.49	9.53
1.43	2.10	3.09	4.53	6.65	9.76

Standard resistance values are obtained from the Decade Table by multiplying by multiples of 10. As an example, 1.21 can represent 1.21 Ω , 12.1 Ω , 121 Ω , 1.21k etc.

Bypass Capacitors

Input bypassing using a 1 μ F tantalum or 25 μ F electrolytic is recommended when the input filter capacitors are more than 5 inches from the device. Improved ripple rejection

(80dB) can be accomplished by adding a 10 μ F capacitor from the ADJ pin to ground. Increasing the size of the capacitor to 20 μ F will help ripple rejection at low output voltage since the reactance of this capacitor should be small compared to the voltage setting resistor, R2. For improved AC transient response and to prevent the possibility of oscillation due to unknown reactive load, a 1 μ F capacitor is also recommended at the output. Because of their low impedance at high frequencies, the best type of capacitor to use is solid tantalum.

Protection Diodes

The LT138A/LT338A do not require a protection diode from the adjustment terminal to the output (see Figure 2). Improved internal circuitry eliminates the need for this diode when the adjustment pin is bypassed with a capacitor to improve ripple rejection.

If a very large output capacitor is used, such as a 100 μ F shown in Figure 2, the regulator could be damaged or destroyed if the input is accidentally shorted to ground or crowbarred, due to the output capacitor discharging into the output terminal of the regulator. To prevent this, a diode D1 as shown, is recommended to safely discharge the capacitor.

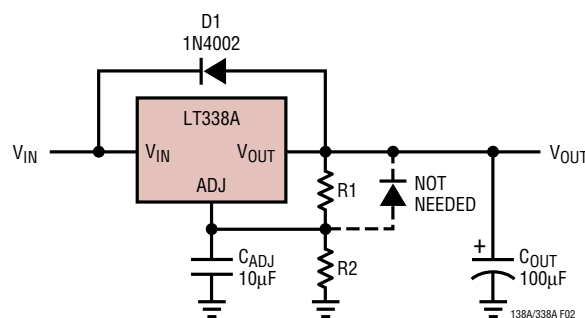

Figure 2

Load Regulation

Because the LT138A is a three-terminal device, it is not possible to provide true remote load sensing. Load regulation will be limited by the resistance of the wire connecting the regulator to the load. The data sheet specification for load regulation is measured at the bottom of the package. Negative side sensing is a true Kelvin connection, with the bottom of the output divider returned to the

APPLICATIONS INFORMATION

negative side of the load. Although it may not be immediately obvious, best load regulation is obtained when the top of the resistor divider, R1, is connected *directly* to the case *not to the load*. This is illustrated in *Figure 3*. If R1 were connected to the load, the effective resistance between the regulator and the load would be:

$$R_P \left(\frac{R_2 + R_1}{R_1} \right), R_P = \text{Parasitic Line Resistance}$$

Connected as shown, R_P is not multiplied by the divider ratio. R_P is about 0.004Ω per foot using 16 gauge wire. This translates to 4mV/ft at 1A load current, so it is important to keep the positive lead between regulator and load as short as possible, and use large wire or PC board traces.

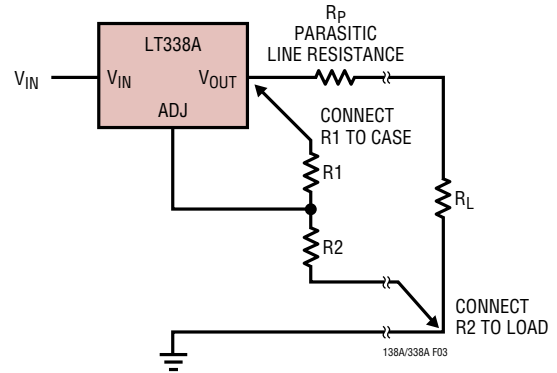
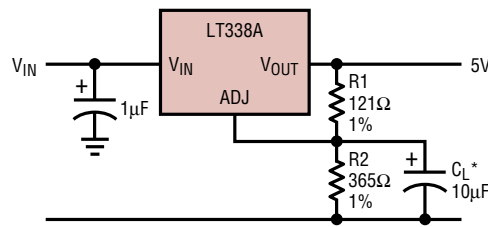

Figure 3. Connections for Best Load Regulation

TYPICAL APPLICATIONS

Improving Ripple Rejection



*C1 IMPROVES RIPPLE REJECTION, X_C SHOULD BE SMALL COMPARED TO R2

1.2V to 25V Adjustable Regulator

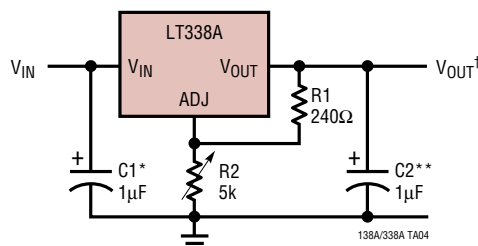

*NEEDED IF DEVICE IS FAR FROM FILTER CAPACITORS
**OPTIONAL, IMPROVES TRANSIENT RESPONSE

$$V_{OUT}^{\dagger} = 1.25V \left(1 + \frac{R_2}{R_1} \right)$$

TYPICAL APPLICATIONS

5V Regulator with Shutdown

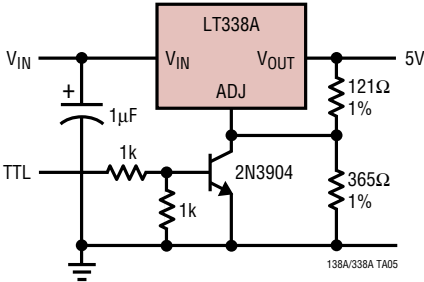

Temperature Compensated Lead Acid Battery Charger

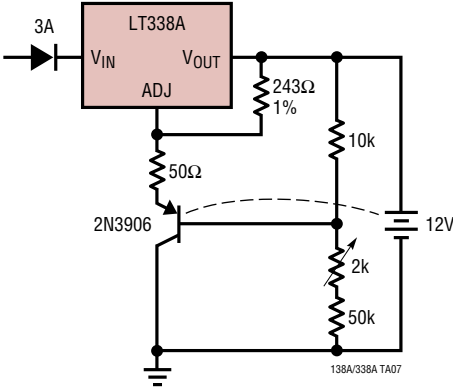

Remote Sensing

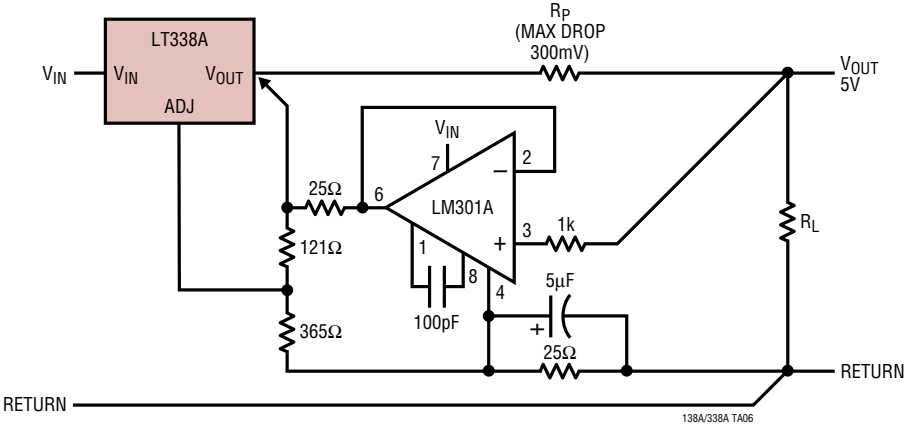

SCHEMATIC DIAGRAM LT138A/LT338A

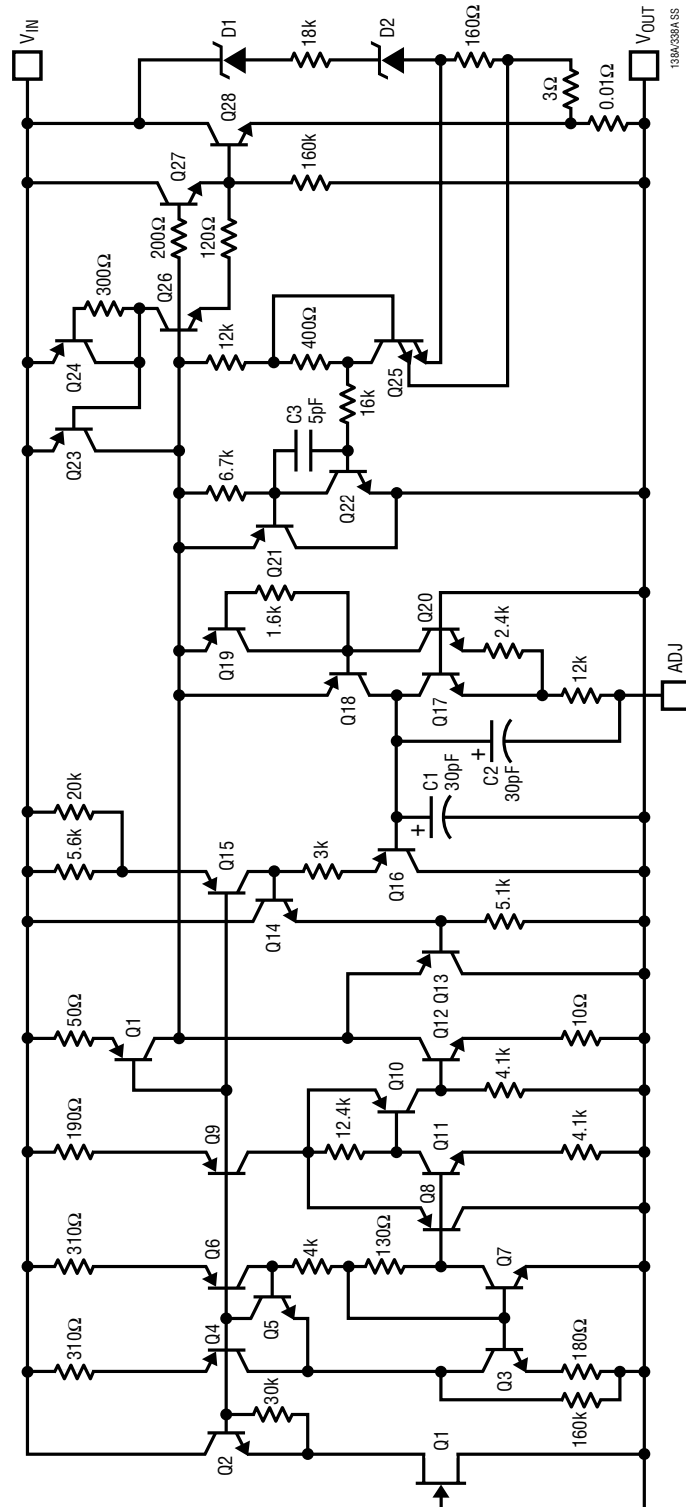

LT138A/LT338A
LM138/LM338

PACKAGE DESCRIPTION

K Package
2-Lead TO-3 Metal Can
(Reference LTC DWG # 05-08-1310)

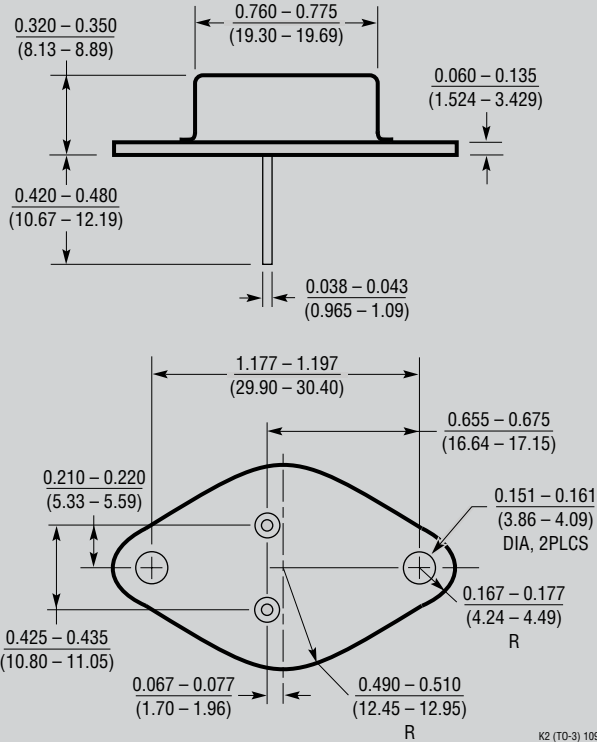

K2 (TO-3) 1098

OBsolete PACKAGE

PACKAGE DESCRIPTION

P Package
3-Lead Plastic TO-3P (Similar to TO-247)
(Reference LTC DWG # 05-08-1450)

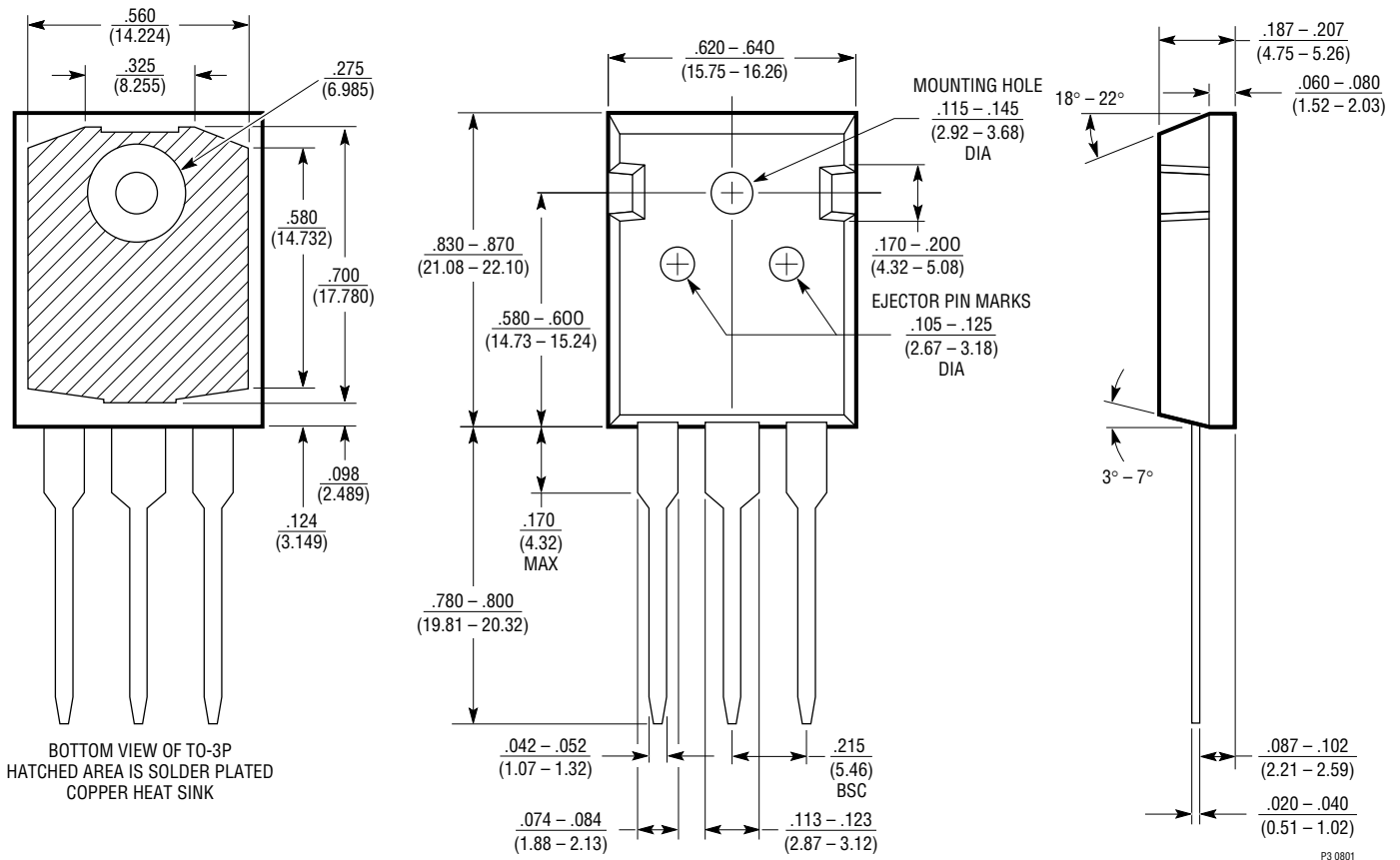

P3 0801

LT138A/LT338A LM138/LM338

TYPICAL APPLICATIONS

Lamp Flasher

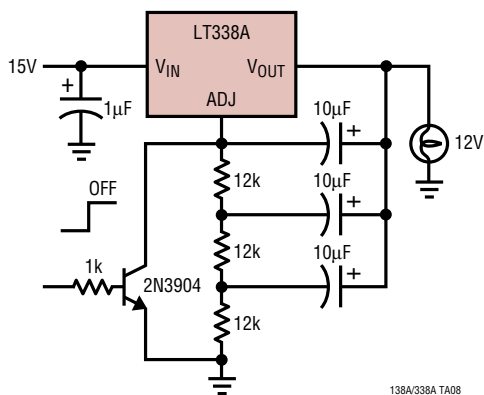

Automatic Light Control

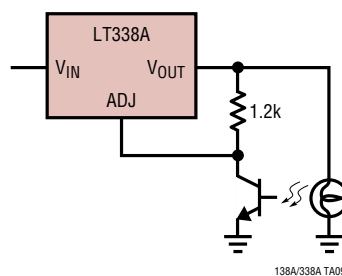

Protected High Current Lamp Driver

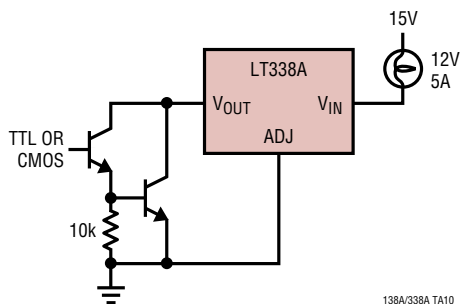

RELATED PARTS

PART NUMBER	DESCRIPTION	COMMENTS
LT1083/LT1084/LT1085	3A/5A/7.5A Low Dropout Regulators	Fixed Outputs, V_{IN} Up to 30V
LT1580	7A Fast Transient Response Regulator with 0.7V Dropout	For 3.3V to 2.xxV Applications
LT1581	10A Fast Transient Response Regulator	For 3.3V to 2.xxV Applications
LT1584/LT1585/LT1587	7A/4.6A/3A Low Dropout Fast Transient Response Regulator	For 1.2V to 3.3V Outputs from 5V
LT1764	3A Fast Transient Response Regulator	Dropout Voltage 340mV, Low Noise: 40µV _{RMS}