



## LM134 Series

# Constant Current Source and Temperature Sensor

## FEATURES

- 1μA to 10mA Operation
- 0.02%/V Regulation
- 0.8V to 40V Operating Voltage
- Can be Used as Linear Temperature Sensor
- Draws No Reverse Current
- Supplied in Standard Transistor Packages

## APPLICATIONS

- Current Mode Temperature Sensing
- Constant Current Source for Shunt References
- Cold Junction Compensation
- Constant-Gain Bias for Bipolar Differential Stage
- Micropower Bias Networks
- Buffer for Photoconductive Cell
- Current Limiter

## DESCRIPTION

The LM134 is a three-terminal current source designed to operate at current levels from 1μA to 10mA, as set by an external resistor. The device operates as a true two-terminal current source, requiring no extra power connections or input signals. Regulation is typically 0.02%/V and terminal-to-terminal voltage can range from 800mV to 40V.

Because the operating current is *directly proportional to absolute temperature* in degrees Kelvin, the device will also find wide applications as a temperature sensor. The temperature dependence of the operating current is 0.336%/°C at room temperature. For example, a device operating at 298μA will have a temperature coefficient of 1μA/°C. The temperature dependence is extremely accurate and repeatable. Devices specified as temperature sensors in the 100μA to 1mA range are the LM134-3, LM234-3 and the LM134-6, LM234-6, with the dash numbers indicating ±3°C and ±6°C accuracies, respectively.

If a zero temperature coefficient current source is required, this is easily achieved by adding a diode and a resistor.

LT, LTC and LT are registered trademarks of Linear Technology Corporation.

## TYPICAL APPLICATION

### Remote Temperature Sensor with Voltage Output

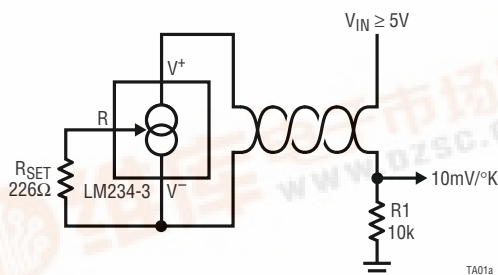

### Operating Current vs Temperature

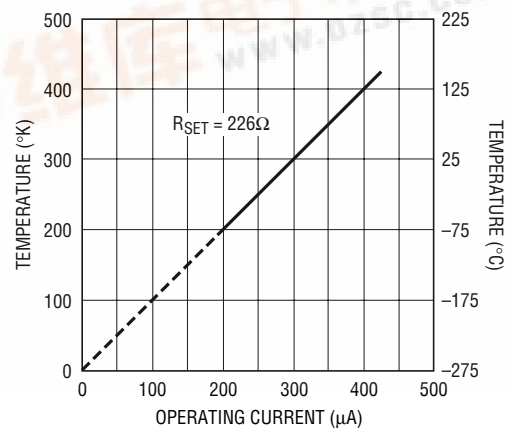

# LM134 Series

## ABSOLUTE MAXIMUM RATINGS (Note 1)

V <sup>+</sup> to V <sup>-</sup> Forward Voltage	Power Dissipation .....	200mW
LM134 .....	Operating Temperature Range	
LM134-3/LM134-6/LM234-3/	LM134 ( <b>OBSOLETE</b> ) .....	-55°C to 125°C
LM234-6/LM334 .....	LM234-3/LM234-6 .....	-25°C to 100°C
V <sup>+</sup> to V <sup>-</sup> Reverse Voltage .....	LM334 .....	0°C to 70°C
R Pin to V <sup>-</sup> Voltage .....	Storage Temperature Range .....	-65°C to 150°C
Set Current .....	Lead Temperature (Soldering, 10 sec) .....	300°C

## PACKAGE/ORDER INFORMATION

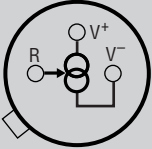
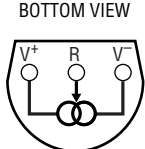
 <p>BOTTOM VIEW</p> <p>H PACKAGE 3-LEAD TO-46 METAL CAN</p> <p>T<sub>JMAX</sub> = 150°C, θ<sub>JA</sub> = 440°C/W, θ<sub>JA</sub> = 80°C/W</p> <p><b>OBSOLETE PACKAGE</b> Consider the S8 or Z Packages for Alternate Source</p>	ORDER PART NUMBER		 <p>BOTTOM VIEW</p> <p>Z PACKAGE 3-LEAD PLASTIC TO-92</p> <p>T<sub>JMAX</sub> = 100°C, θ<sub>JA</sub> = 160°C/W</p>	ORDER PART NUMBER	
	CURRENT SOURCE	TEMP SENSOR		CURRENT SOURCE	TEMP SENSOR
LM134H	LM134H-3	LM334Z	LM234Z-3		
LM334H	LM234H-3		LM234Z-6		
	LM134H-6				
	LM234H-6				
			ORDER PART NUMBER		
			LM334S8		
			S8 PART MARKING		
			334		

Consult LTC Marketing for availability of LM234Z-3 and LM234Z-6

## ELECTRICAL CHARACTERISTICS

### CURRENT SOURCE (Note 2)

SYMBOL	PARAMETER	CONDITIONS	LM134			LM334			UNITS
			MIN	TYP	MAX	MIN	TYP	MAX	
$\Delta I_{SET}$	Set Current Error, $V^+ = 2.5V$ (Note 3)	$10\mu A \leq I_{SET} \leq 1mA$			3			6	%
		$1mA < I_{SET} \leq 5mA$			5			8	%
		$2\mu A \leq I_{SET} < 10\mu A$			8			12	%
	Ratio of Set Current to $V^-$ Current	$10\mu A \leq I_{SET} \leq 1mA$ $1mA \leq I_{SET} \leq 5mA$ $2\mu A \leq I_{SET} \leq 10\mu A$	14	18	23	14	18	26	
$V_{MIN}$	Minimum Operating Voltage	$2\mu A \leq I_{SET} \leq 100\mu A$		0.8			0.8		V
		$100\mu A < I_{SET} \leq 1mA$		0.9			0.9		V
		$1mA < I_{SET} \leq 5mA$		1.0			1.0		V
$\frac{\Delta I_{SET}}{\Delta V_{IN}}$	Average Change in Set Current with Input Voltage	$1.5V \leq V^+ \leq 5V$ $2\mu A \leq I_{SET} \leq 1mA$ $5V \leq V^+ \leq V_{MAX}$ (Note 5)		0.02	0.05		0.02	0.1	%/V
		$1.5V \leq V \leq 5V$ $1mA < I_{SET} \leq 5mA$ $5V \leq V \leq V_{MAX}$ (Note 5)		0.01	0.03		0.01	0.05	%/V
		$1.5V \leq V \leq 5V$ $1mA < I_{SET} \leq 5mA$ $5V \leq V \leq V_{MAX}$ (Note 5)		0.03			0.03		%/V
	Temperature Dependence of Set Current (Note 4)	$25\mu A \leq I_{SET} \leq 1mA$	0.96		1.04	0.96		1.04	
$C_S$	Effective Shunt Capacitance			15			15		pF

### TEMPERATURE SENSOR (Note 2)

SYMBOL	PARAMETER	CONDITIONS	LM134-3, LM234-3			LM134-6, LM234-6			UNITS
			MIN	TYP	MAX	MIN	TYP	MAX	
$\Delta I_{SET}$	Set Current Error, $V^+ = 2.5V$ (Note 3)	$100\mu A \leq I_{SET} \leq 1mA$ $T_j = 25^\circ C$			$\pm 1$			$\pm 2$	%
		Equivalent Temperature Error			$\pm 3$			$\pm 6$	$^\circ C$
	Ratio of Set Current to $V^-$ Current	$100\mu A \leq I_{SET} \leq 1mA$	14	18	26	14	18	26	
$V_{MIN}$	Minimum Operating Voltage	$100\mu A \leq I_{SET} \leq 1mA$		0.9			0.9		V
$\frac{\Delta I_{SET}}{\Delta V_{IN}}$	Average Change in Set Current with Input Voltage	$1.5V \leq V^+ \leq 5V$ $100\mu A \leq I_{SET} \leq 1mA$ $5V \leq V^+ \leq 30V$		0.02	0.05		0.02	0.1	%/V
		$1.5V \leq V \leq 5V$ $100\mu A \leq I_{SET} \leq 1mA$ $5V \leq V \leq 30V$		0.01	0.03		0.01	0.05	%/V
	Temperature Dependence of Set Current (Note 4)	$100\mu A \leq I_{SET} \leq 1mA$	0.98		1.02	0.97		1.03	
	Equivalent Slope Error			$\pm 2$			$\pm 3$		%
$C_S$	Effective Shunt Capacitance			15			15		pF

**Note 1:** Absolute Maximum Ratings are those values beyond which the life of a device may be impaired.

**Note 2:** Unless otherwise specified, tests are performed at  $T_j = 25^\circ C$  with pulse testing so that junction temperature does not change during test.

**Note 3:** Set current is the current flowing into the  $V^+$  pin. It is determined by the following formula:  $I_{SET} = 67.7mV/R_{SET}$  (at  $25^\circ C$ ). Set current error

is expressed as a percent deviation from this amount.  $I_{SET}$  increases at  $0.336\%/^\circ C$  at  $T_j = 25^\circ C$ .

**Note 4:**  $I_{SET}$  is nominally directly proportional to absolute temperature ( $^\circ K$ ).  $I_{SET}$  at any temperature can be calculated from:  $I_{SET} = I_0 (T/T_0)$  where  $I_0$  is  $I_{SET}$  measured at  $T_0$  ( $^\circ K$ ).

**Note 5:**  $V_{MAX} = 40V$  for LM134 and  $30V$  for other grades.

# LM134 Series

## TYPICAL PERFORMANCE CHARACTERISTICS

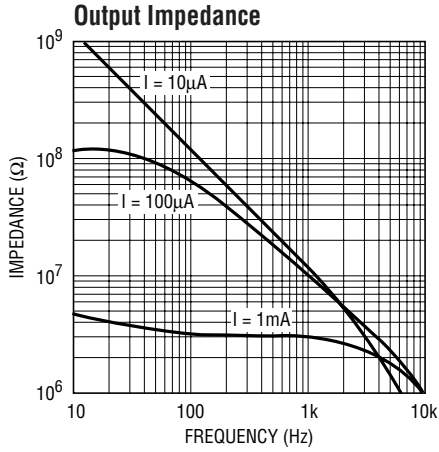

134 G01

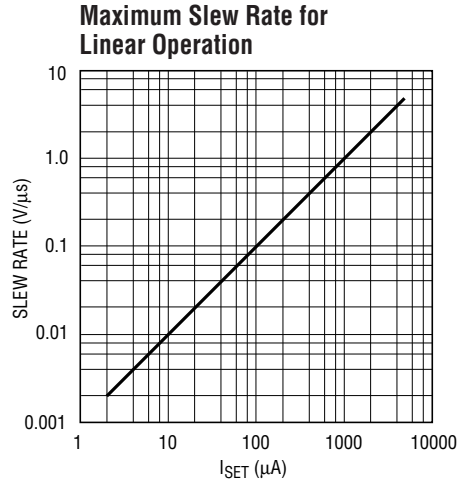

134 G02

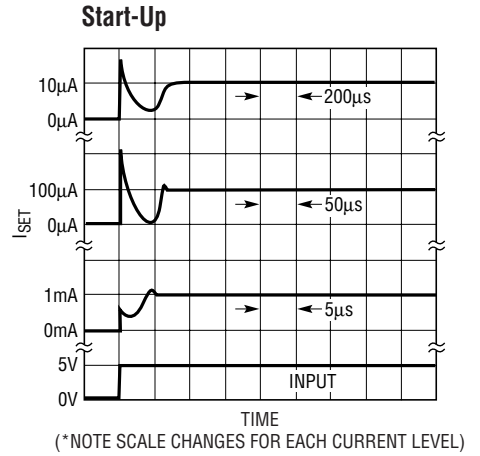

134 G03

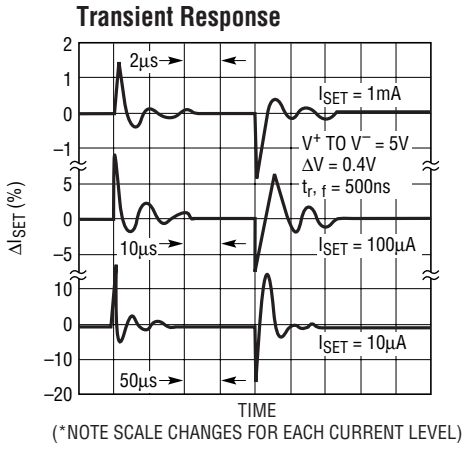

134 G04

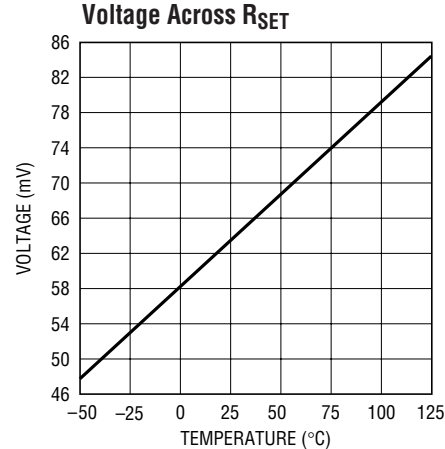

1314/15 G01

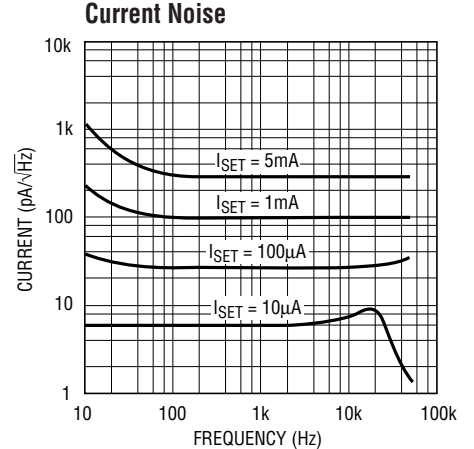

134 G06

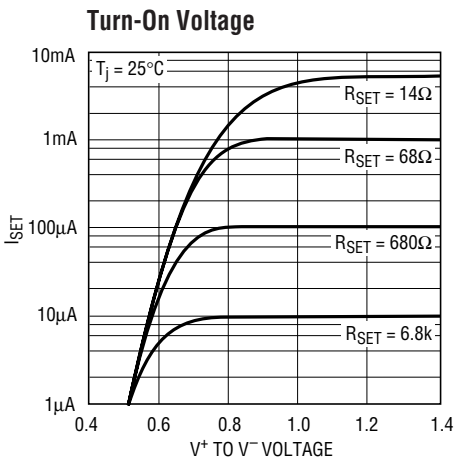

134 G02

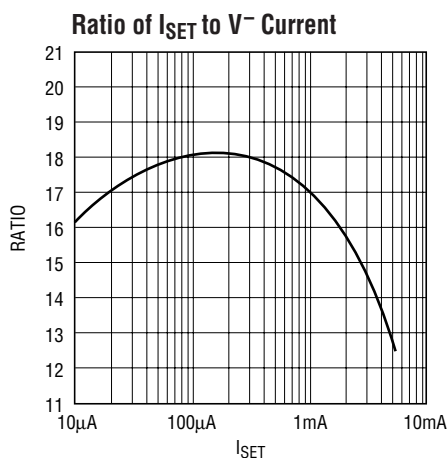

134 G08

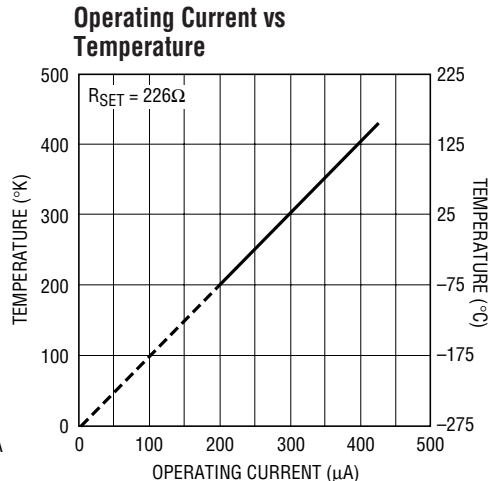

134 G09

## APPLICATIONS INFORMATION

### Basic Theory of Operation

The equivalent circuit of the LM134 is shown in Figure 1. A reference voltage of 64mV is applied to the minus input of A1 with respect to the  $V^-$  pin. A1 serves the drive to Q2 to keep the R pin at 64mV, independent of the value of  $R_{SET}$ . Transistor Q1 is matched to Q2 at a 17:1 ratio so that the current flowing out of the  $V^-$  pin is always 1/18 of the total current into the  $V^+$  pin. This total current is called  $I_{SET}$  and is equal to:

$$\left( \frac{64\text{mV}}{R_{SET}} \right) \left( \frac{18}{17} \right) = \frac{67.7\text{mV}}{R_{SET}}$$

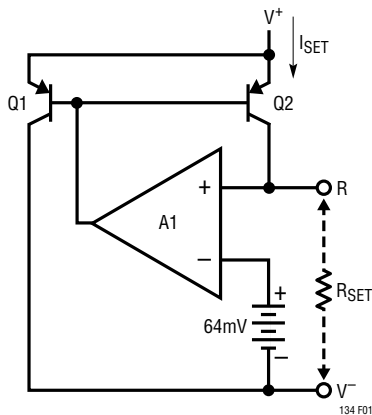

Figure 1.

The 67.7mV equivalent reference voltage is directly proportional to absolute temperature in degrees Kelvin (see curve, "Operating Current vs Temperature"). This means that the reference voltage can be plotted as a straight line going from 0mV at absolute zero temperature to 67.7mV at 298°K (25°C). The slope of this line is 67.7mV/298 = 227 $\mu$ V/°C.

The accuracy of the device is specified as a percent error at room temperature, or in the case of the -3 and -6 devices, as both a percent error and an equivalent temperature error. The LM134 operating current changes at a percent rate equal to  $(100)(227\mu\text{V}/^\circ\text{C})/(67.7\text{mV}) = 0.336\%/^\circ\text{C}$  at 25°C, so each 1% operating current error is equivalent to  $\approx 3^\circ\text{C}$  temperature error when the device is used as a temperature sensor. The slope accuracy (temperature coefficient) of the LM134 is expressed as a ratio compared to unity. The LM134-3, for instance, is specified at 0.98 to 1.02, indicating that the maximum slope error of

the device is  $\pm 2\%$  when the room temperature current is set to the exact desired value.

### Supply Voltage Slew Rate

At slew rates above a given threshold (see curve), the LM134 may exhibit nonlinear current shifts. The slewing rate at which this occurs is directly proportional to  $I_{SET}$ . At  $I_{SET} = 10\mu\text{A}$ , maximum  $dv/dt$  is 0.01V/ $\mu\text{s}$ ; at  $I_{SET} = 1\text{mA}$ , the limits is 1V/ $\mu\text{s}$ . Slew rates above the limit do not harm the LM134, or cause large currents to flow.

### Thermal Effects

Internal heating can have a significant effect on current regulation for  $I_{SET}$  greater than 100 $\mu\text{A}$ . For example, each 1V increase across the LM134 at  $I_{SET} = 1\text{mA}$  will increase junction temperature by  $\approx 0.4^\circ\text{C}$  in still air. Output current ( $I_{SET}$ ) has a temperature coefficient of  $\approx 0.33\%/^\circ\text{C}$ , so the change in current due to temperature rise will be  $(0.4)(0.33) = 0.132\%$ . This is a 10:1 degradation in regulation compared to true electrical effects. Thermal effects, therefore, must be taken into account when DC regulation is critical and  $I_{SET}$  exceeds 100 $\mu\text{A}$ . Heat sinking of the TO-46 package or the TO-92 leads can reduce this effect by more than 3:1.

### Shunt Capacitance

In certain applications, the 15pF shunt capacitance of the LM134 may have to be reduced, either because of loading problems or because it limits the AC output impedance of the current source. This can be easily accomplished by buffering the LM134 with a FET, as shown in the applications. This can reduce capacitance to less than 3pF and improve regulation by at least an order of magnitude. DC characteristics (with the exception of minimum input voltage) are not affected.

### Noise

Current noise generated by the LM134 is approximately 4 times the shot noise of a transistor. If the LM134 is used as an active load for a transistor amplifier, input referred noise will be increased by about 12dB. In many cases, this is acceptable and a single stage amplifier can be built with a voltage gain exceeding 2000.

# LM134 Series

## APPLICATIONS INFORMATION

### Lead Resistance

The sense voltage which determines the operating current of the LM134 is less than 100mV. At this level, thermocouple or lead resistance effects should be minimized by locating the current setting resistor physically close to the device. Sockets should be avoided if possible. It takes only  $0.7\Omega$  contact resistance to reduce output current by 1% at the 1mA level.

### Start-Up Time

The LM134 is designed to operate at currents as low as  $1\mu\text{A}$ . This requires that internal biasing current be well below that level because the device achieves its wide operating current range by using part of the operating current as bias current for the internal circuitry. To ensure start-up, however, a fixed trickle current must be provided internally. This is typically in the range of 20nA to 200nA and is provided by the special ultralow  $I_{\text{DSS}}$  FETs shown in the Schematic Diagrams as Q7 and Q8. The start-up time of the LM134 is determined by the  $I_{\text{DSS}}$  of these FETs and the capacitor C1. This capacitor must charge to approximately 500mV before Q3 turns on to start normal circuit operation. This takes as long as  $(500\text{mV})(50\text{pF})/(20\text{nA}) = 1.25\text{ms}$  for very low  $I_{\text{DSS}}$  values.

### Using the LM134 as a Temperature Sensor

Because it has a highly linear output characteristic, the LM134 makes a good temperature sensor. It is particularly useful in remote sensing applications because it is a current output device and is therefore not affected by long wire runs. It is easy to calibrate, has good long term stability and can be interfaced directly with most data acquisition systems, eliminating the expensive preamplifiers required for thermocouples and platinum sensors.

A typical temperature sensor application is shown in Figure 2. The LM134 operating current at  $25^\circ\text{C}$  is set at  $298\mu\text{A}$  by the  $226\Omega$  resistor, giving an output of  $1\mu\text{A}/^\circ\text{K}$ . The current flows through the twisted pair sensor leads to the 10k termination resistor, which converts the current output to a voltage of  $10\text{mV}/^\circ\text{K}$  referred to ground. The

voltage across the 10k resistor will be 2.98V at  $25^\circ\text{C}$ , with a slope of  $10\text{mV}/^\circ\text{C}$ . The simplest way to convert this signal to a Centigrade scale is to subtract a constant 2.73V in software. Alternately, a hardware conversion can be used, as shown in Figure 3, using an LT1009 as a level shifter to offset the output to a Centigrade scale.

The resistor ( $R_{\text{SET}}$ ) used to set the operating current of the LM134 in temperature sensing applications should have low temperature coefficient and good long term stability. A  $30\text{ppm}/^\circ\text{C}$  drift in the resistor will change the slope of the temperature sensor by 1%, assuming that the resistor is at the same temperature as the sensor, which is usually the case since the resistor should be located physically close to the LM134 to prevent errors due to wire resistance. A long term shift of 0.3% in the resistor will create a  $1^\circ\text{C}$  temperature error. The long term drift of the LM134 is typically much better than this, so stable resistors must be used for best long term performance.

Calibration of the LM134 as a temperature sensor is extremely easy. Referring to Figure 2, calibration is achieved by trimming the termination resistor. *This theoretically trims both zero and slope simultaneously for Centigrade and Fahrenheit applications.* The initial errors in the LM134 are directly proportional to absolute temperature, just like the actual output. This allows the sensor to be trimmed at any temperature and have the slope error be corrected at the same time. Residual slope error is typically less than 1% after this single trim is completed.

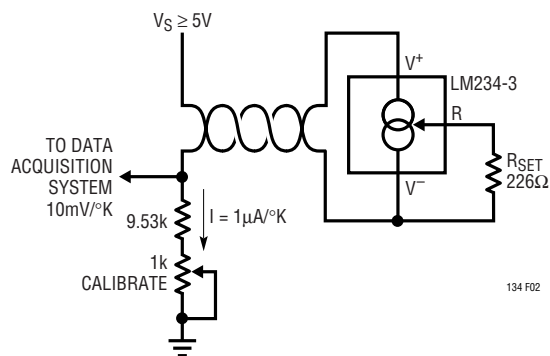

Figure 2 Kelvin Temperature Sensor

## APPLICATIONS INFORMATION

The two trims shown in Figure 3 are still intended to be a “one point” temperature calibration, where the zero and the slope are trimmed at a single temperature. The LT1009 reference is adjusted to give 2.700V at node “a” at  $T_{\text{SENSOR}} = 25^{\circ}\text{C}$ . The 1k trimmer then adjusts the output for 0.25V, completing the calibration. If the calibration is to be done at a temperature other than  $25^{\circ}\text{C}$ , trim the LT1009 for  $2.7025 - (1\mu\text{A})[T_{\text{SENSOR}} (^{\circ}\text{C})](100\Omega)$  at node “a”, then adjust the 1k trimmer for proper output.

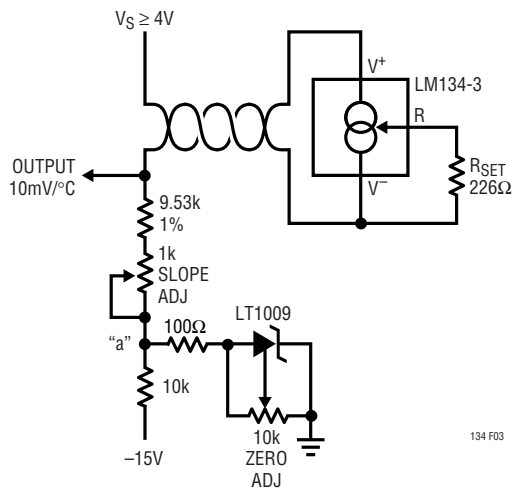

Figure 3. Centigrade Temperature Sensor

If higher accuracy is required, a two point calibration technique can be used. In Figure 4, separate zero and slope trims are provided. Residual nonlinearity is now the limitation on accuracy. Nonlinearity of the LM134 in a  $100^{\circ}\text{C}$  span is typically less than  $0.5^{\circ}\text{C}$ . This particular method of trimming has the advantage that the slope trim does not interact with the zero trim. Trim procedure is to adjust for zero output with  $T_{\text{SENSOR}} = 0^{\circ}\text{C}$ , then trim slope for proper output at some convenient second temperature. No further trimming is required.

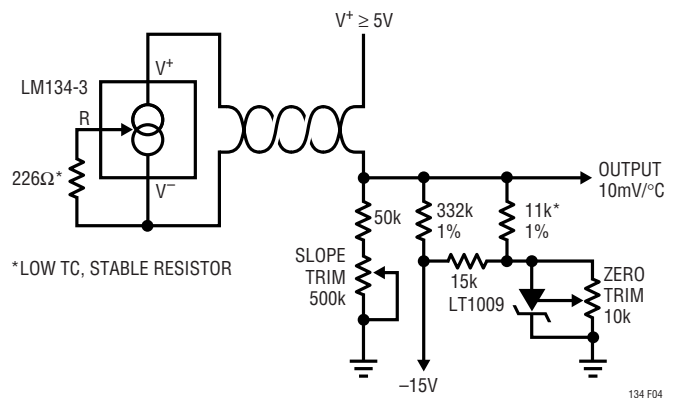
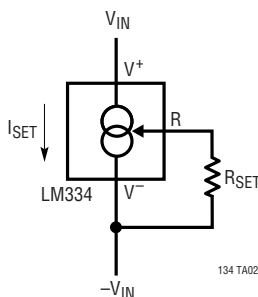

Figure 4. Centigrade Temperature Sensor with 2 Point Trim

## TYPICAL APPLICATIONS

### Basic 2-Terminal Current Source



134 TA02

### Low Output Impedance Thermometer (Kelvin Output)

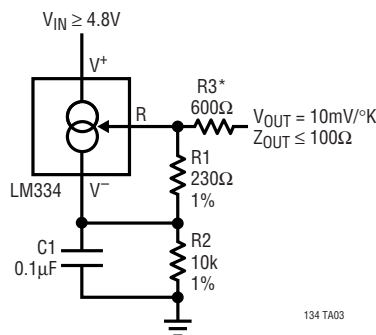

134 TA03

### Zero Temperature Coefficient Current Source

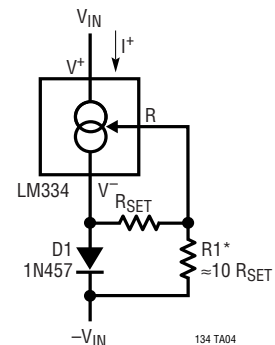

134 TA04

\*OUTPUT IMPEDANCE OF THE LM134 AT THE “R” PIN IS APPROXIMATELY  $-\frac{R_0}{16} \Omega$ , WHERE  $R_0$  IS THE EQUIVALENT EXTERNAL RESISTANCE CONNECTED TO THE  $V^-$  PIN. THIS NEGATIVE RESISTANCE CAN BE REDUCED BY A FACTOR OF 5 OR MORE BY INSERTING AN EQUIVALENT RESISTOR IN SERIES WITH THE OUTPUT.

\*SELECT RATIO OF  $R_1$  TO  $R_{\text{SET}}$  TO OBTAIN ZERO DRIFT.  $I^+ \approx 2 I_{\text{SET}}$ .



# LM134 Series

## TYPICAL APPLICATIONS

### Higher Output Current

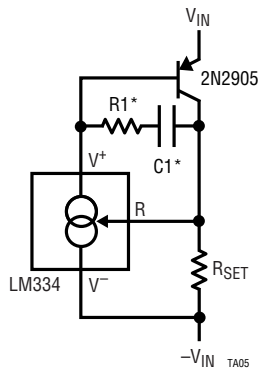

\*SELECT R1 AND C1 FOR OPTIMUM STABILITY

### Low Output Impedance Thermometer

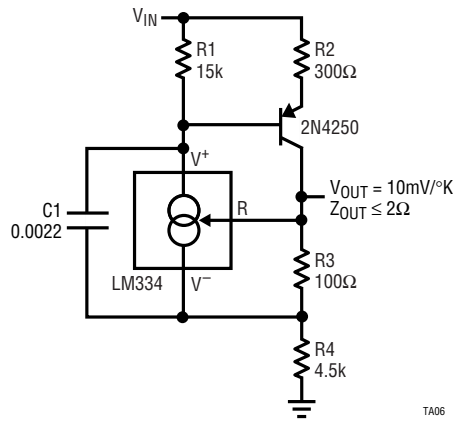

TA06

### Low Input Voltage Reference Driver

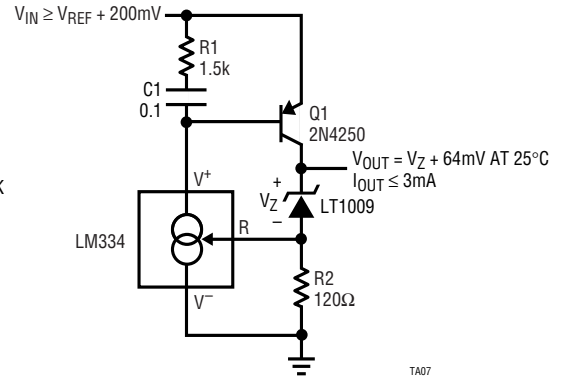

TA07

### Micropower Bias

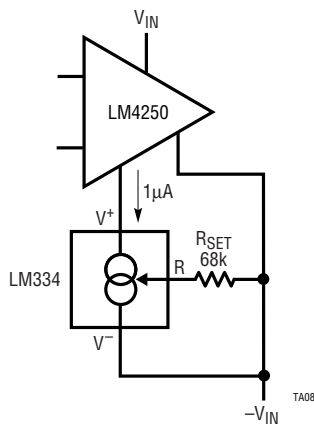

TA08

### 1.2V Regulator with 1.8V Minimum Input

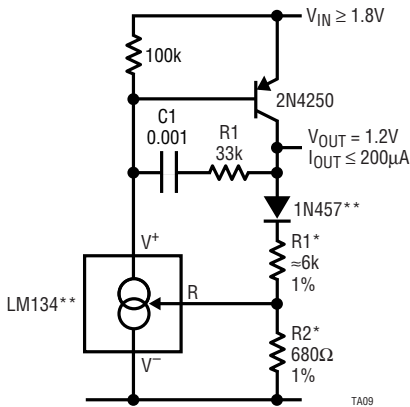

TA09

\*SELECT RATIO OF R1 TO R2 FOR ZERO TEMPERATURE DRIFT  
\*\*LM134 AND DIODE SHOULD BE ISOTHERMAL

### Zener Biasing

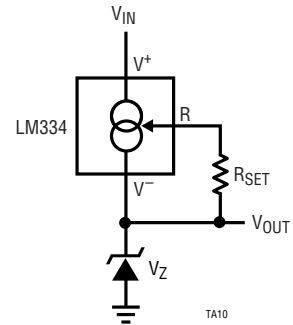

TA10

### Alternate Trimming Technique

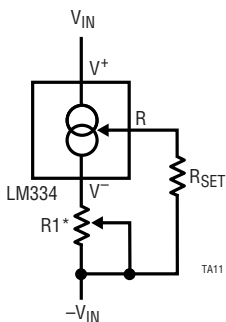

TA11

\*FOR ±10% ADJUSTMENT, SELECT RSET 10% HIGH AND MAKE R1 ≈ 3RSET

### Buffer for Photoconductive Cell

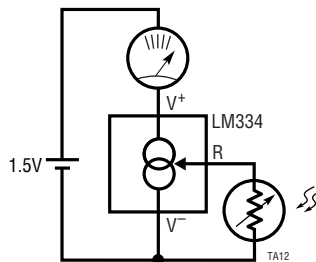

TA12

### High Precision Low TC Current Source

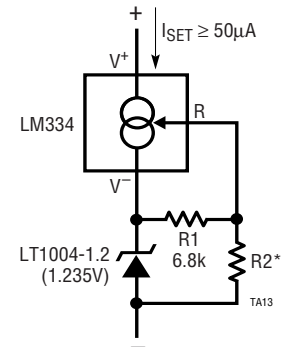

TA13

\* $I_{SET} = \frac{1.37V}{R2} + 10\mu A$   
 $I_{SET} TC = 0.016\%/^{\circ}C + 33nA/^{\circ}C$   
REGULATION ≈ 0.001%/V



# TYPICAL APPLICATIONS

Precision 10nA Current Source

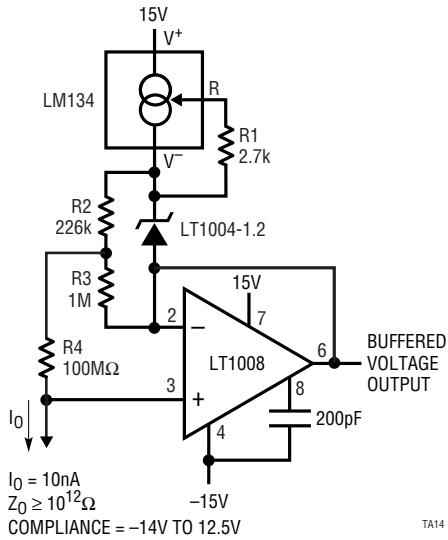

TA14

Micropower 5V Reference

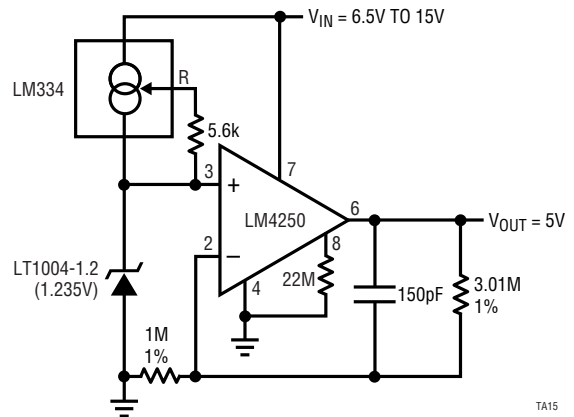

TA15

FET Cascoding for Low Capacitance and/or Ultrahigh Output Impedance

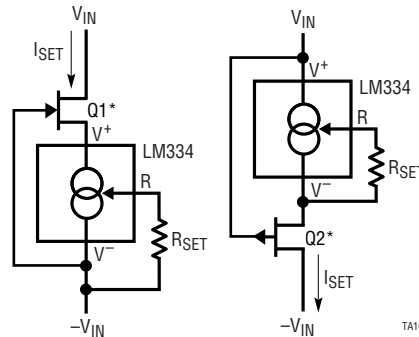

TA16

\*SELECT Q1 OR Q2 TO ENSURE AT LEAST 1V ACROSS THE LM134.  $V_P (1 - I_{SET}/I_{DSS}) \geq 1.2V$ .

# SCHEMATIC DIAGRAM

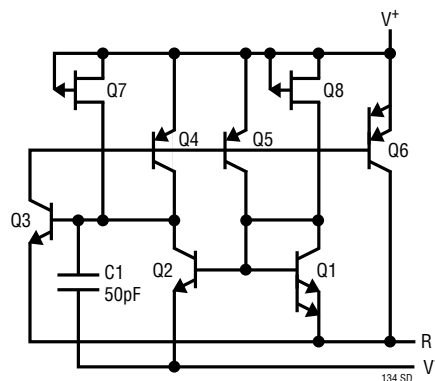

134 SD

# LM134 Series

## PACKAGE DESCRIPTION

### H Package 2-Lead and 3-Lead TO-46 Metal Can (Reference LTC DWG # 05-08-1340)

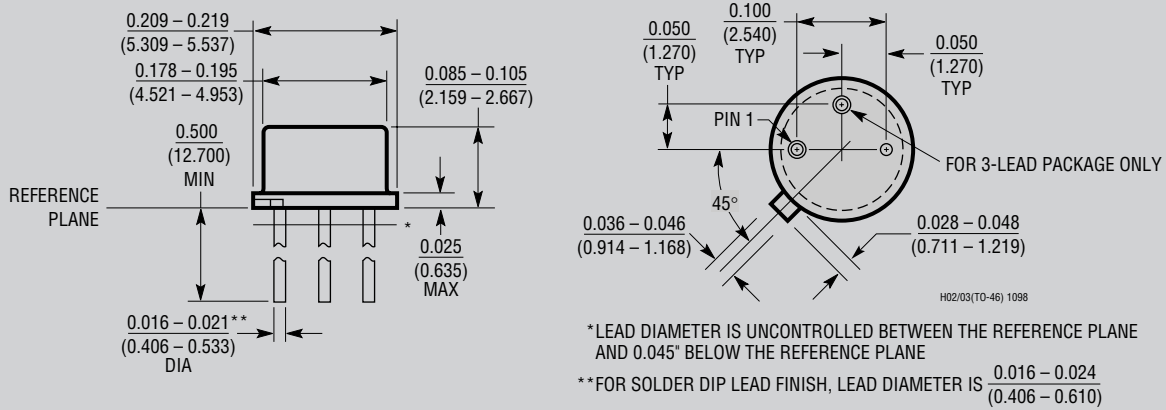

**OBSOLETE PACKAGE**

### Z Package 3-Lead Plastic TO-92 (Similar to TO-226) (Reference LTC DWG # 05-08-1410)

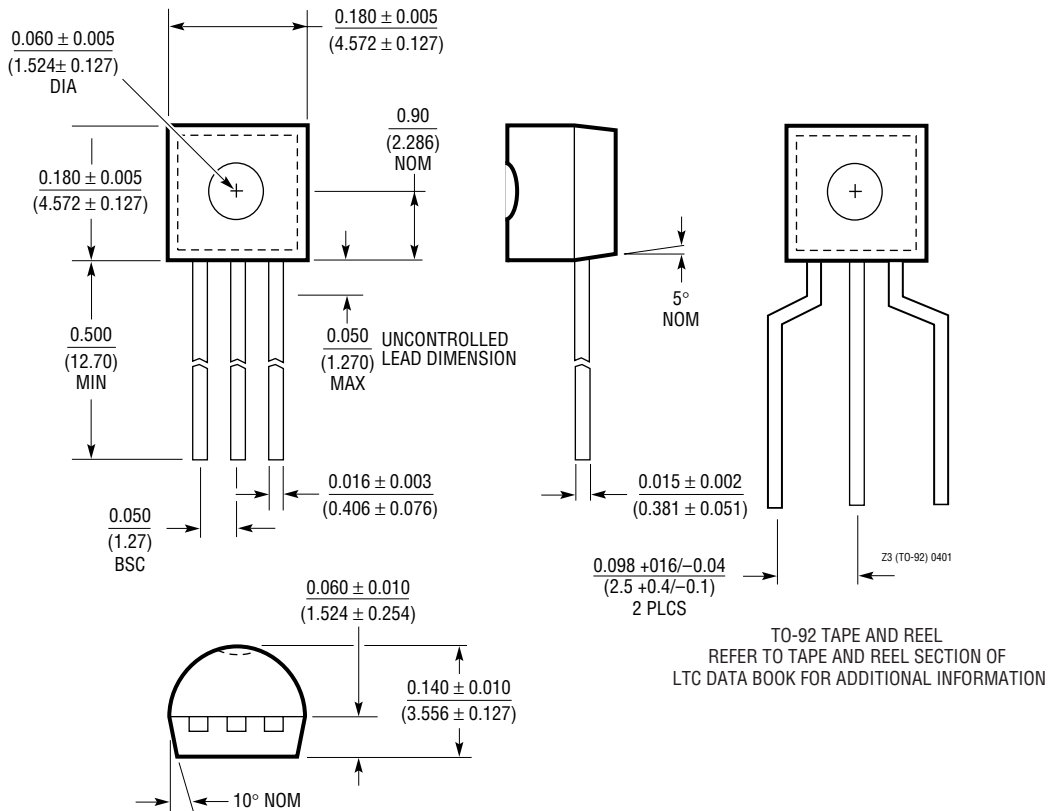

**PACKAGE DESCRIPTION**

**S8 Package**  
**8-Lead Plastic Small Outline (Narrow .150 Inch)**  
 (Reference LTC DWG # 05-08-1610)

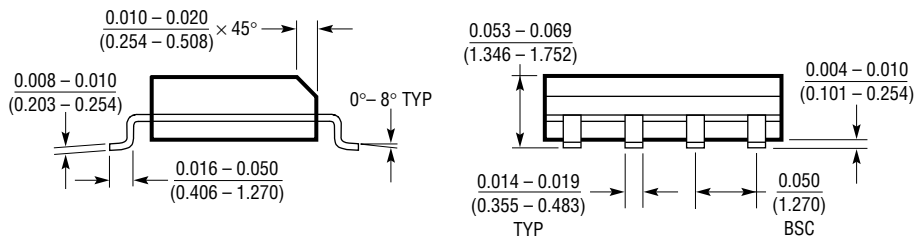
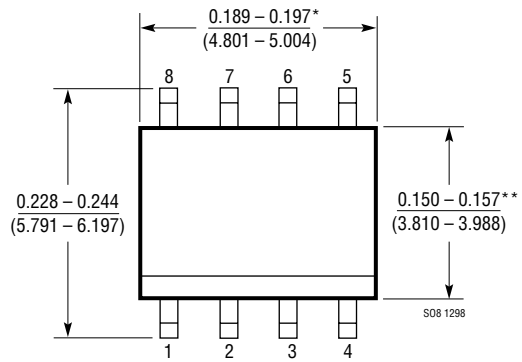

\*DIMENSION DOES NOT INCLUDE MOLD FLASH. MOLD FLASH SHALL NOT EXCEED 0.006" (0.152mm) PER SIDE

\*\*DIMENSION DOES NOT INCLUDE INTERLEAD FLASH. INTERLEAD FLASH SHALL NOT EXCEED 0.010" (0.254mm) PER SIDE

# LM134 Series

## TYPICAL APPLICATIONS

**In-Line Current Limiter**

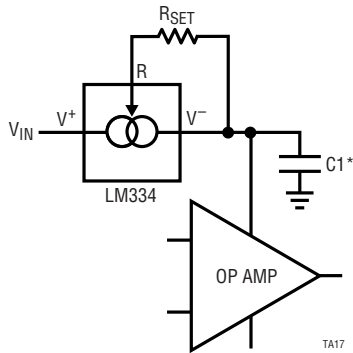

\*USE MINIMUM VALUE REQUIRED TO ENSURE STABILITY OF PROTECTED DEVICE. THIS MINIMIZES INRUSH CURRENT TO A DIRECT SHORT.

**Generating Negative Output Impedance**

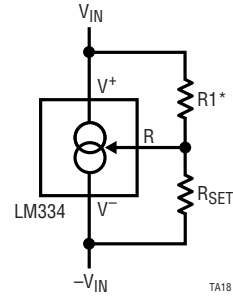

\* $Z_{OUT} = -16 \cdot R1(R1/V_{IN}$  MUST NOT EXCEED  $I_{SET}$ ).

**Ground Referred Fahrenheit Thermometer**

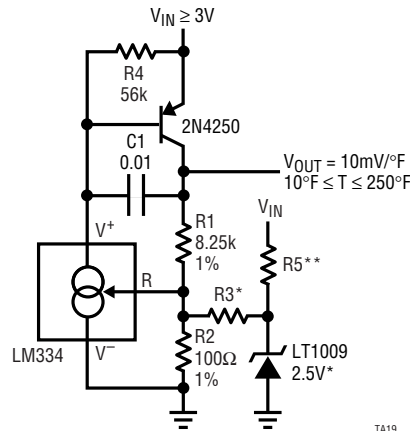

\*SELECT  $R3 = V_{REF}/583\mu A$   
 \*\*SELECT FOR 1.2mA