



LT1033

# 3A Negative Adjustable Regulator

**NOT RECOMMENDED FOR NEW DESIGNS**  
Contact Linear Technology for Potential Replacement

## FEATURES

- *Guaranteed* 1% Initial Voltage Tolerance
- *Guaranteed* 0.015%/V Line Regulation
- *Guaranteed* 0.02%/W Thermal Regulation

## PRECONDITIONING

- 100% Thermal Limit Burn-in

## APPLICATIONS

- Adjustable Power Supplies
- System Power Supplies
- Precision Voltage/Current Regulators
- On-Card Regulators

## DESCRIPTION

The LT<sup>®</sup>1033 negative adjustable regulator will deliver up to 3A output current over an output voltage range of -1.2V to -32V. Linear Technology has made significant improvements in these regulators compared to previous devices, such as better line and load regulation, and a maximum output voltage error of 1%.

The LT1033 is easy to use and difficult to damage. Internal current and power limiting as well as true thermal limiting prevents device damage due to overloads or shorts, even if the regulator is not fastened to a heat sink.

Maximum reliability is attained with Linear Technology's advanced processing techniques combined with a 100% burn-in in the thermal limit mode. This assures that all device protection circuits are working and eliminates field failures experienced with other regulators that receive only standard electrical testing.

LT, LTC and LT are registered trademarks of Linear Technology Corporation.

## TYPICAL APPLICATION

Negative 5V Regulator

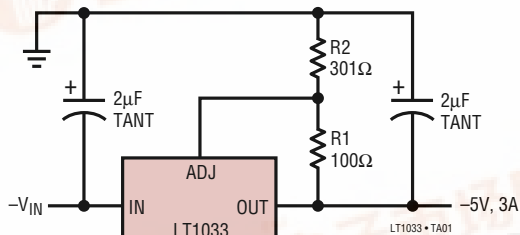

Current Limit

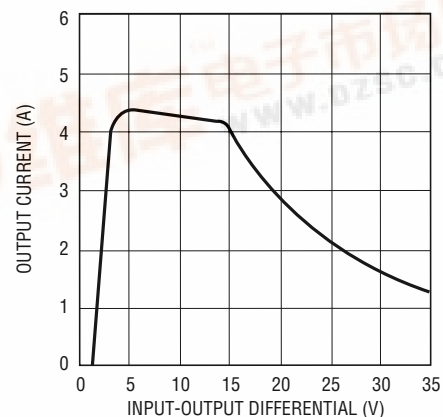

LT1033 • G01



# LT1033

## ABSOLUTE MAXIMUM RATINGS (Note 1)

Power Dissipation ..... Internally Limited  
 Input to Output Voltage Differential ..... 35V  
 Operating Junction Temperature Range  
 LT1033M (OBSOLETE) ..... -55°C to 150°C  
 LT1033C ..... 0°C to 125°C

Storage Temperature Range  
 LT1033M (OBSOLETE) ..... -65°C to 150°C  
 LT1033C ..... -65°C to 150°C  
 Lead Temperature (Soldering, 10 sec.) ..... 300°C

## PACKAGE/ORDER INFORMATION

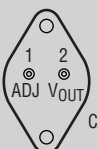
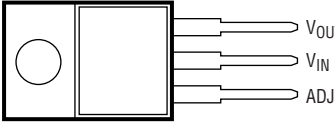
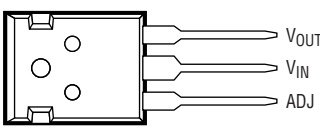
<p>BOTTOM VIEW</p>  <p>CASE IS V<sub>IN</sub></p> <p>K PACKAGE          4-LEAD TO-3 METAL CAN          T<sub>JMAX</sub> = 150°C, θ<sub>JA</sub> = 35°C/W(MK)          T<sub>JMAX</sub> = 125°C, θ<sub>JA</sub> = 35°C/W(CK)</p> <p><b>OBSOLETE PACKAGE</b>          Consider the P or T Packages for Alternate Source</p>	<p>FRONT VIEW</p>  <p>CASE IS V<sub>IN</sub></p> <p>T PACKAGE          3-LEAD PLASTIC TO-220          T<sub>JMAX</sub> = 125°C, θ<sub>JA</sub> = 50°C/W</p>	<p>FRONT VIEW</p>  <p>CASE IS V<sub>IN</sub></p> <p>P PACKAGE          3-LEAD PLASTIC TO-3P          T<sub>JMAX</sub> = 125°C, θ<sub>JA</sub> = 35°C/W</p>
ORDER PART NUMBER	ORDER PART NUMBER	ORDER PART NUMBER
LT1033MK LT1033CK	LT1033CT	LT1033CP

Consult LTC Marketing for parts specified with wider operating temperature ranges.

## ELECTRICAL CHARACTERISTICS (Note 2)

The ● denotes specifications which apply over the full operating temperature range, otherwise specifications are T<sub>A</sub> = 25°C.

SYMBOL	PARAMETER	CONDITIONS	LT1033M			LT1033C			UNITS
			MIN	TYP	MAX	MIN	TYP	MAX	
V <sub>REF</sub>	Reference Voltage	V <sub>IN</sub> - V <sub>OUT</sub>   = 5V, I <sub>OUT</sub> = 5mA, T <sub>J</sub> = 25°C	-1.238	-1.250	-1.262	-1.238	-1.250	-1.262	V
		3V ≤  V <sub>IN</sub> - V <sub>OUT</sub>   ≤ 35V 5mA ≤ I <sub>OUT</sub> ≤ I <sub>MAX</sub> , P ≤ P <sub>MAX</sub>	●	-1.215	-1.250	-1.285	-1.200	-1.250	-1.300
ΔV <sub>OUT</sub> / ΔI <sub>OUT</sub>	Load Regulation	10mA ≤ I <sub>OUT</sub> ≤ I <sub>MAX</sub> , (Note 3) T <sub>J</sub> = 25°C,  V <sub>OUT</sub>   ≤ 5V		10	50		10	50	mV
		T <sub>J</sub> = 25°C,  V <sub>OUT</sub>   ≥ 5V		0.2	1.0		0.2	1.0	%
		V <sub>OUT</sub>   ≤ 5V	●	20	75		20	75	mV
		V <sub>OUT</sub>   ≥ 5V	●	0.4	1.5		0.4	1.5	%
ΔV <sub>OUT</sub> / ΔV <sub>IN</sub>	Line Regulation	3V ≤  V <sub>IN</sub> - V <sub>OUT</sub>   ≤ 35V, (Note 2) T <sub>J</sub> = 25°C		0.005	0.015		0.01	0.02	%/V
		●		0.01	0.04		0.02	0.05	%/V
	Ripple Rejection	V <sub>OUT</sub> = -10V, f = 120Hz C <sub>ADJ</sub> = 0	56	66			60		dB
		C <sub>ADJ</sub> = 10μF	70	80		66	77		dB
	Thermal Regulation	T <sub>J</sub> = 25°C, 10ms Pulse		0.002	0.02		0.002	0.02	%/W

## ELECTRICAL CHARACTERISTICS (Note 2)

The ● denotes specifications which apply over the full operating temperature range, otherwise specifications are  $T_A = 25^\circ\text{C}$ .

SYMBOL	PARAMETER	CONDITIONS	LT1033M			LT1033C			UNITS
			MIN	TYP	MAX	MIN	TYP	MAX	
$I_{ADJ}$	Adjust Pin Current		●	65	100		65	100	$\mu\text{A}$
$\Delta I_{ADJ}$	Adjust Pin Current Change	$10\text{mA} \leq I_{OUT} \leq I_{MAX}$ $3\text{V} \leq  V_{IN} - V_{OUT}  \leq 35\text{V}$	●	0.2	2	●	0.5	2	$\mu\text{A}$
	Minimum Load Current	$ V_{IN} - V_{OUT}  \leq 35\text{V}$ $ V_{IN} - V_{OUT}  \leq 10\text{V}$		2.5	5.0		2.5	5.0	$\text{mA}$
				1.2	3.0		1.2	3.0	$\text{mA}$
$I_{SC}$	Current Limit	$ V_{IN} - V_{OUT}  \leq 10\text{V}$ , (Note 3) $ V_{IN} - V_{OUT}  = 35\text{V}$ , $T_J = 25^\circ\text{C}$		3	4.3	6	3	4.3	A
				0.5	1.3	2.5	0.5	1.3	A
$\frac{\Delta V_{OUT}}{\Delta \text{Temp}}$	Temperature Stability of Output Voltage	$T_{MIN} \leq T \leq T_{MAX}$	●	0.6	1.5		0.6	1.5	%
$\frac{\Delta V_{OUT}}{\Delta \text{Time}}$	Long Term Stability	$T_A = 125^\circ\text{C}$ , 1000 Hours		0.3	1.0		0.3	1.0	%
$e_n$	RMS Output Noise (% of $V_{OUT}$ )	$T_A = 25^\circ\text{C}$ , $10\text{Hz} \leq f \leq 10\text{kHz}$		0.003			0.003		%
$\theta_{JC}$	Thermal Resistance Junction to Case	T Package K Package P Package					2.5 1.2 1.8	4.0 2.0 2.7	$^\circ\text{C}/\text{W}$ $^\circ\text{C}/\text{W}$ $^\circ\text{C}/\text{W}$

**Note 1:** Absolute Maximum Ratings are those values beyond which the life of a device may be impaired.

**Note 2:** Unless otherwise indicated, these specifications apply:  $|V_{IN} - V_{OUT}| = 5\text{V}$ ; and  $I_{OUT} = 5\text{mA}$ . Power dissipation is internally limited. However, these specifications apply for power dissipation up to 30W.

See guaranteed minimum output current curve.  $I_{MAX} = 3\text{A}$ .

**Note 3:** Testing is done using a pulsed low duty cycle technique. See thermal regulation specifications for output changes due to heating effects. Load regulation is measured on the output pin at a point 1/8" below the base of the package.

## TYPICAL PERFORMANCE CHARACTERISTICS

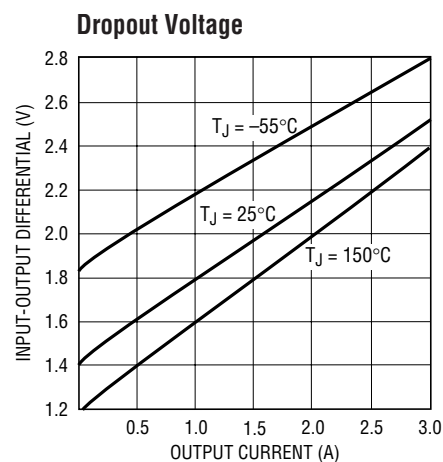

LT1033 • G02

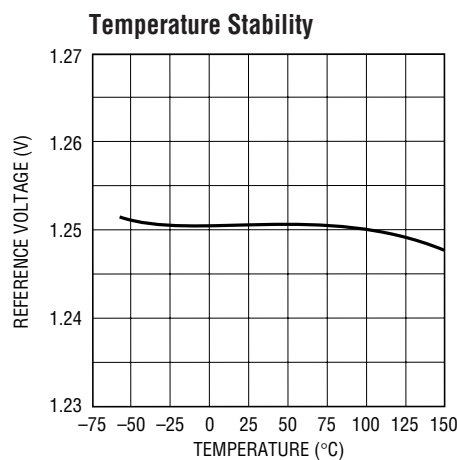

LT1033 • G03

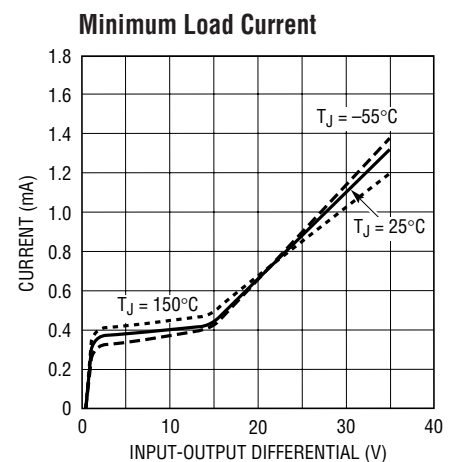

LT1033 • G04

## TYPICAL PERFORMANCE CHARACTERISTICS

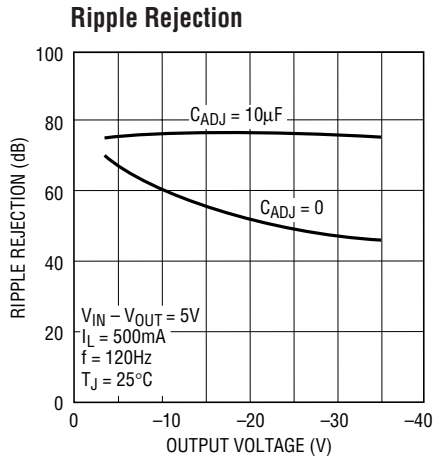

LT1033 • G05

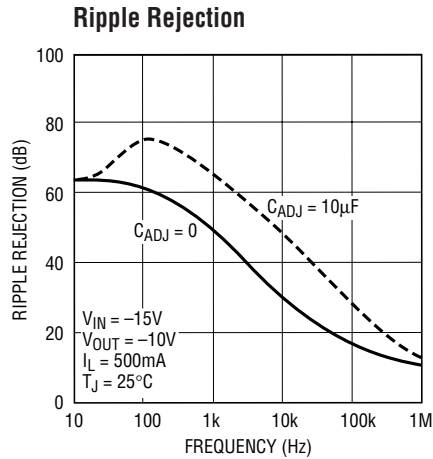

LT1033 • G06

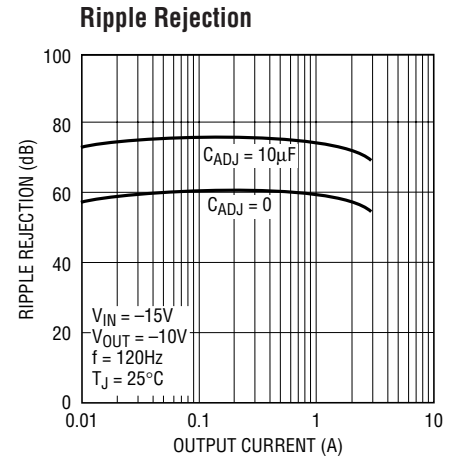

LT1033 • G07

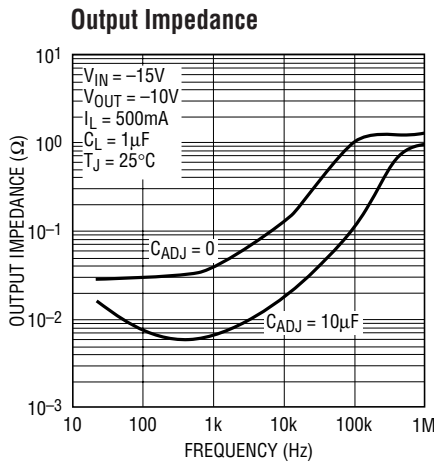

LT1033 • G08

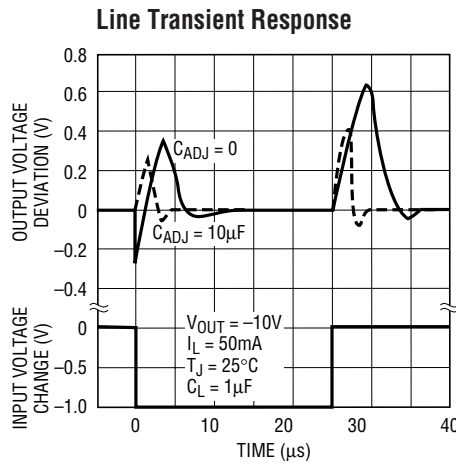

LT1033 • G09

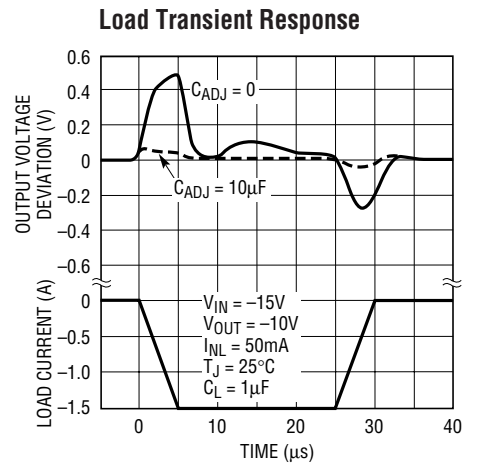

LT1033 • G10

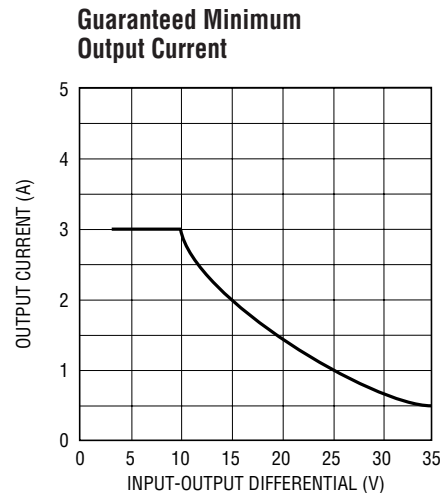
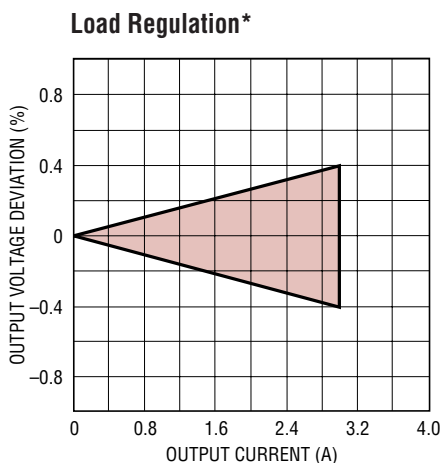

LT1033 • G12

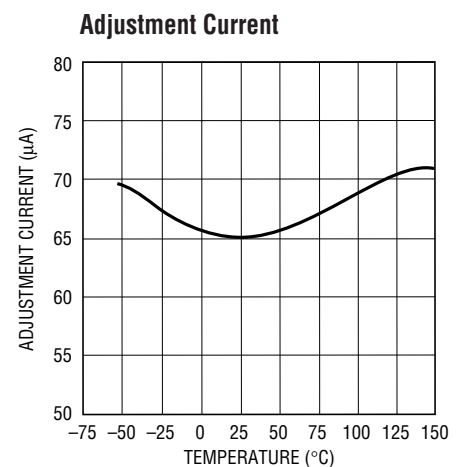

LT1033 • G13

\*THE LT1033 HAS LOAD REGULATION COMPENSATION WHICH MAKES THE TYPICAL UNIT READ CLOSE TO ZERO. THIS BAND REPRESENTS THE TYPICAL PRODUCTION SPREAD

## APPLICATIONS INFORMATION

### Output Voltage

The output voltage is determined by two external resistors, R1 and R2 (see Figure 1). The exact formula for the output voltage is:

$$V_{OUT} = V_{REF} \left( 1 + \frac{R2}{R1} \right) + I_{ADJ}(R2)$$

Where:  $V_{REF}$  = Reference Voltage,  $I_{ADJ}$  = Adjustment Pin Current. In most applications, the second term is small enough to be ignored, typically about 0.5% of  $V_{OUT}$ . In more critical applications, the exact formula should be used, with  $I_{ADJ}$  equal to 65 $\mu$ A. Solving for R2 yields:

$$R2 = \frac{V_{OUT} - V_{REF}}{\frac{V_{REF}}{R1} - I_{ADJ}}$$

Smaller values of R1 and R2 will reduce the influence of  $I_{ADJ}$  on the output voltage, but the no-load current drain on the regulator will be increased. Typical values for R1 are between 100 $\Omega$  and 300 $\Omega$ , giving 12.5mA and 4.2mA no-load current respectively. There is an additional consideration in selecting R1, the minimum load current specification of the regulator. The operating current of the LT1033 flows from input to output. If this current is not absorbed by the load, the output of the regulator will rise above the regulated value. The current drawn by R1 and R2 is normally high enough to absorb the current, but care must be taken in no-load situations where R1 and R2 have high values. The maximum value for the operating current,

which must be absorbed, is 5mA for the LT1033. If input-output voltage differential is less than 10V, the operating current that must be absorbed drops to 3mA.

### Capacitors and Protection Diodes

An output capacitor, C3, is required to provide proper frequency compensation of the regulator feedback loop. A 2 $\mu$ F or larger solid tantalum capacitor is generally sufficient for this purpose if the 1MHz impedance of the capacitor is 1 $\Omega$  or less. High Q capacitors, such as Mylar, are not recommended because their extremely low ESR (effective series resistance) can drastically reduce phase margin. When these types of capacitors must be used because of other considerations, add a 0.5 $\Omega$  carbon resistor in series with 1 $\mu$ F. Aluminum electrolytic capacitors may be used, but the minimum value should be 25 $\mu$ F to ensure a low impedance at 1MHz. The output capacitor should be located within a few inches of the regulator to keep lead impedance to a minimum. The following caution should be noted: if the output voltage is greater than 6V and an output capacitor greater than 20 $\mu$ F has been used, it is possible to damage the regulator if the input voltage becomes shorted, due to the output capacitor discharging into the regulator. This can be prevented by using diode D1 (see Figure 2) between the input and the output.

The input capacitor, C2, is only required if the regulator is more than 4 inches from the raw supply filter capacitor.

### Bypassing the Adjustment Pin

The adjustment pin of the LT1033 may be bypassed with a capacitor to ground, C1, to reduce output ripple, noise, and impedance. These parameters scale directly with output voltage if the adjustment pin is not bypassed. A bypass capacitor reduces ripple, noise and impedance to that of a 1.25V regulator. In a 15V regulator for example, these parameters are improved by 15V/1.25V = 12 to 1. This improvement holds only for those frequencies where the impedance of the bypass capacitor is less than R1. Ten microfarads is generally sufficient for 60Hz power line applications where the ripple frequency is 120Hz, since  $X_C = 130\Omega$ . The capacitor should have a voltage rating at least as high as the output voltage of the regulator. Values

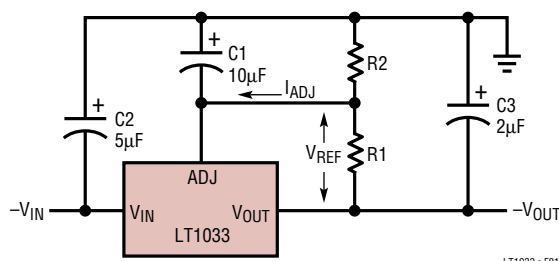

EXAMPLE:  
1. A PRECISION 10V REGULATOR TO SUPPLY UP TO 3A LOAD CURRENT.

A. SELECT  $R1 = 100\Omega$  TO MINIMIZE EFFECT OF  $I_{ADJ}$

B. CALCULATE  $R2 = \frac{V_{OUT} - V_{REF}}{\frac{V_{REF}}{R1} - I_{ADJ}} = \frac{10V - 1.25V}{\frac{1.25V}{100\Omega} - 65\mu A} = 704\Omega$

Figure 1

## APPLICATIONS INFORMATION

larger than  $10\mu\text{F}$  may be used, but if the output is larger than 25V, a diode, D2, should be added between the output and adjustment pins (see Figure 2).

### Proper Connection of Divider Resistors

The LT1033 has a load regulation specification of 0.8% and is measured at a point 1/8" from the bottom of the package. To prevent degradation of load regulation, the resistors which set output voltage, R1 and R2, must be connected as shown in Figure 3. Note that the positive side of the load has a true force and sense (Kelvin) connection, but the negative side of the load does not.

R1 should be connected *directly* to the output lead of the regulator, as close as possible to the specified point 1/8" from the case. R2 should be connected to the positive side of the load separately from the positive (ground) connection to the raw supply. With this arrangement, load regulation is degraded only by the resistance between the regulator output pin and the load. If R1 is connected to the load, regulation will be degraded.

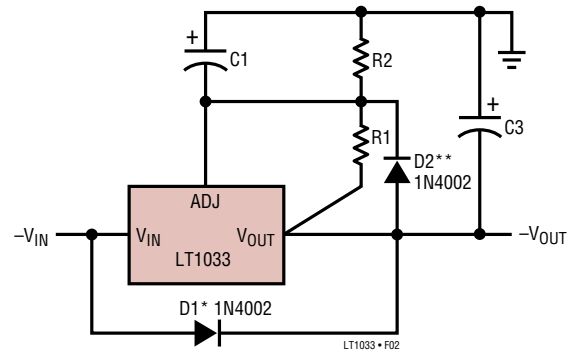

\*D1 PROTECTS THE REGULATOR FROM INPUT SHORTS TO GROUND. IT IS REQUIRED ONLY WHEN C3 IS LARGER THAN  $20\mu\text{F}$  AND  $V_{OUT}$  IS LARGER THAN 6V

\*\* D2 PROTECTS THE ADJUST PIN OF THE REGULATOR FROM OUTPUT SHORTS IF C2 IS LARGER THAN  $10\mu\text{F}$  AND  $V_{OUT}$  IS LARGER THAN -25V

Figure 2

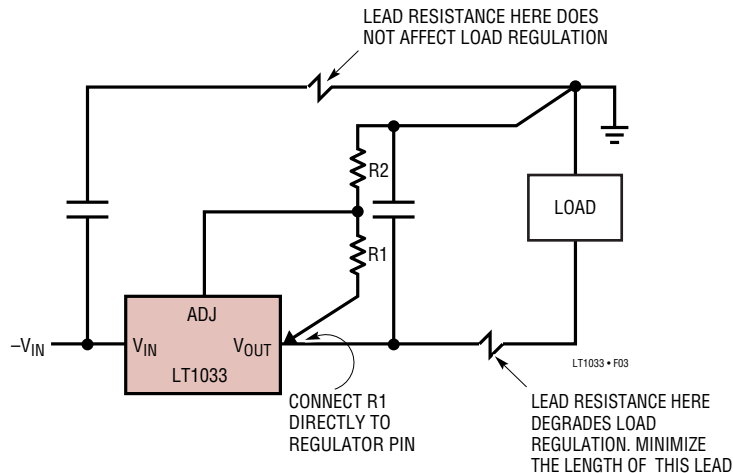

Figure 3

## TYPICAL APPLICATIONS

The output stability, load regulation, line regulation, thermal regulation, temperature drift, long term drift, and noise can be improved by a factor of 6.6 over the standard regulator configuration. This assumes a zener whose drift and noise is considerably better than the regulator itself. The LM329B has 20ppm/°C maximum drift and about 10 times lower noise than the regulator.

In the application shown below, regulators #2 to "N" will track regulator #1 to within ±24mV initially, and to ±60mV over all load, line, and temperature conditions. If any regulator output is shorted to ground, all other outputs will drop to ≈ -2V. Load regulation of regulators #2 to "N" will be improved by  $V_{OUT}/1.25V$  compared to a standard regulator, so regulator #1 should be the one which has the lowest load current.

High Stability Regulator

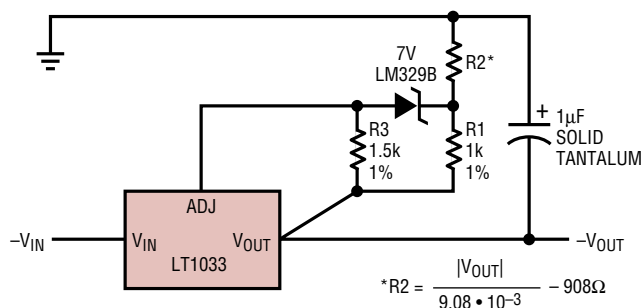

LT1033 • TA06

Multiple Tracking Regulators

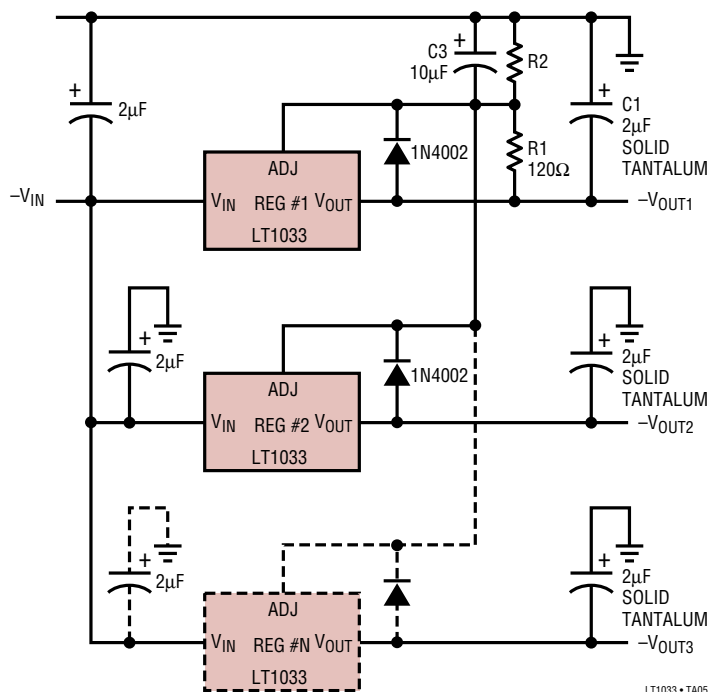

LT1033 • TA05

Dual Tracking 3A Supply ± 1.25V to ± 20V

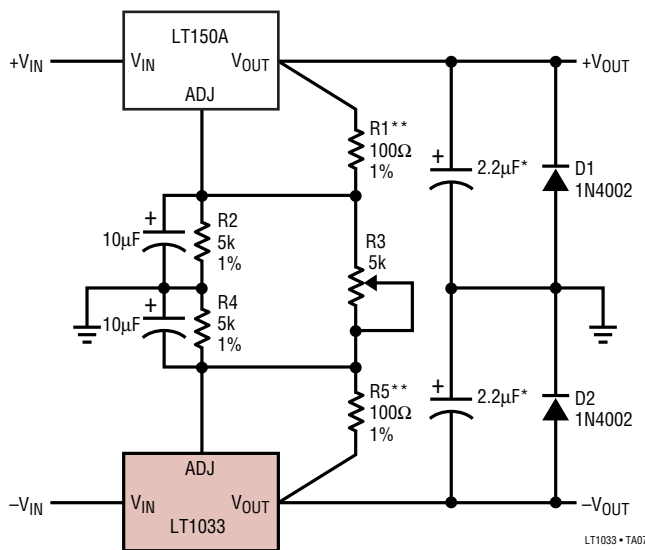

LT1033 • TA07

\*SOLID TANTALUM  
\*\*R1 OR R5 MAY BE TRIMMED SLIGHTLY TO IMPROVE TRACKING

Current Regulator

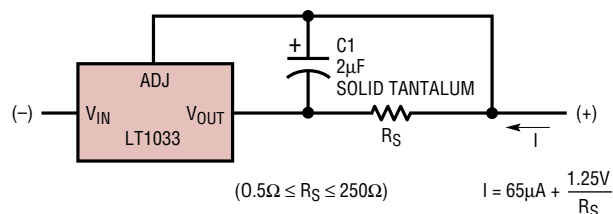

LT1033 • TA08

LT1033

# SCHEMATIC DIAGRAM

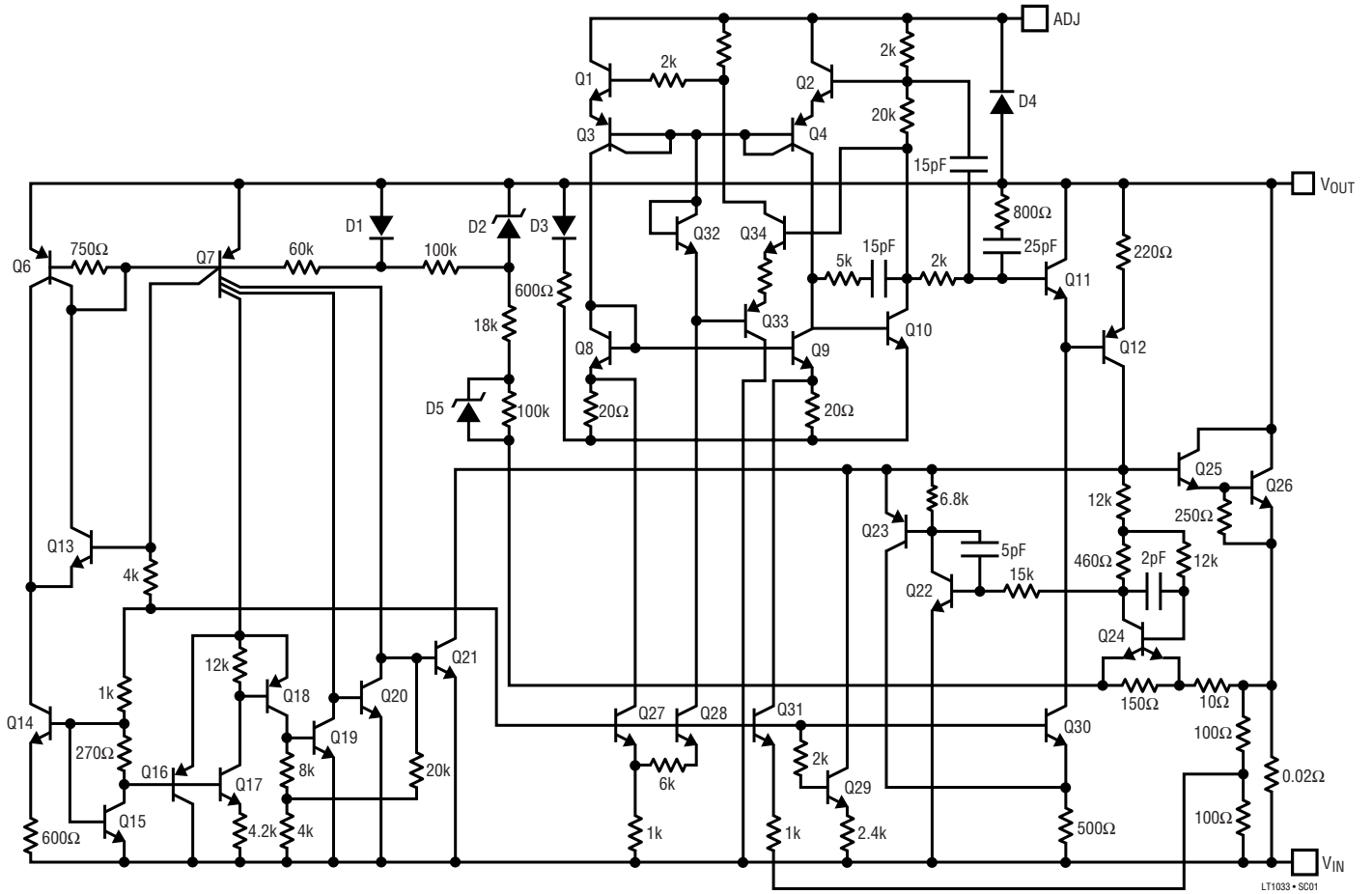

## PROGRAM RESISTOR SELECTION

The following table allows convenient selection of program resistors from standard 1% values.

V <sub>OUT</sub>	R1	R2	OUTPUT ERROR (%)
5	100	301	0.6
6	121	453	-0.7
8	115	619	0.6
10	115	806	0.6
12	118	1020	1.0
15	100	1100	0.5
18	150	2000	0.2
20	121	1820	0.8
22	130	2150	0.2
24	121	2210	0.9
28	115	2430	-0.7
30	121	2740	-0.9

## PACKAGE DESCRIPTION

**K Package**  
**2-Lead TO-3 Metal Can**  
 (Reference LTC DWG # 05-08-1310)

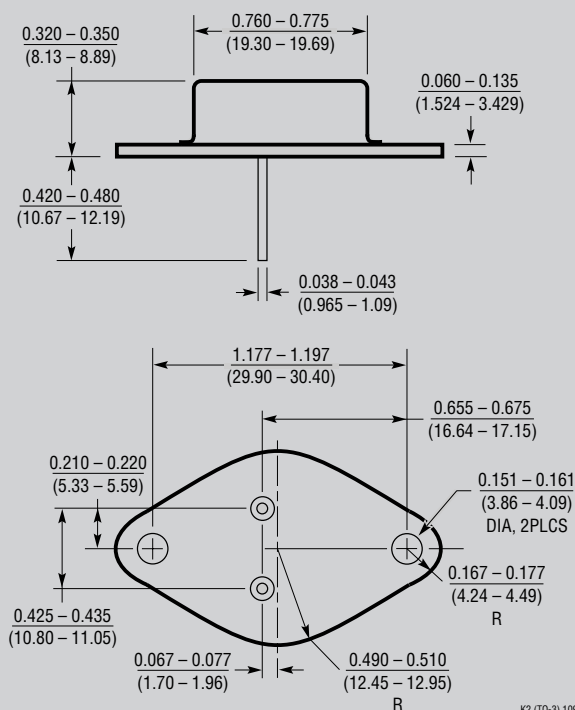

**OBSOLETE  
 PACKAGE**

K2 (TO-3) 1098

LT1033

## PACKAGE DESCRIPTION

**T Package**  
**3-Lead Plastic TO-220**  
(Reference LTC DWG # 05-08-1420)

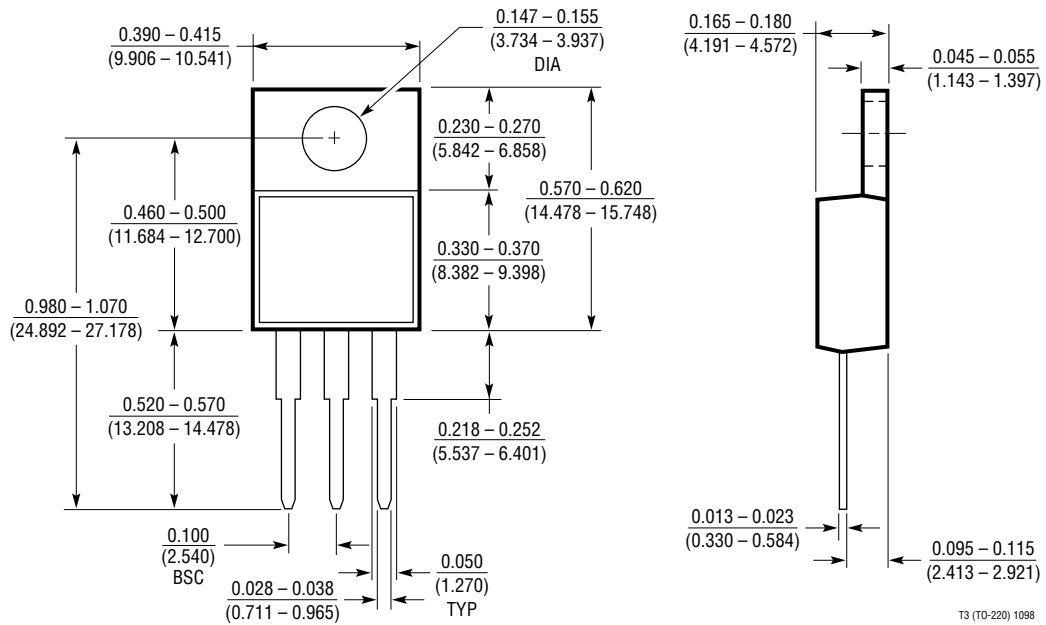

# PACKAGE DESCRIPTION

**P Package**  
**3-Lead Plastic TO-3P (Similar to TO-247)**  
 (Reference LTC DWG # 05-08-1450)

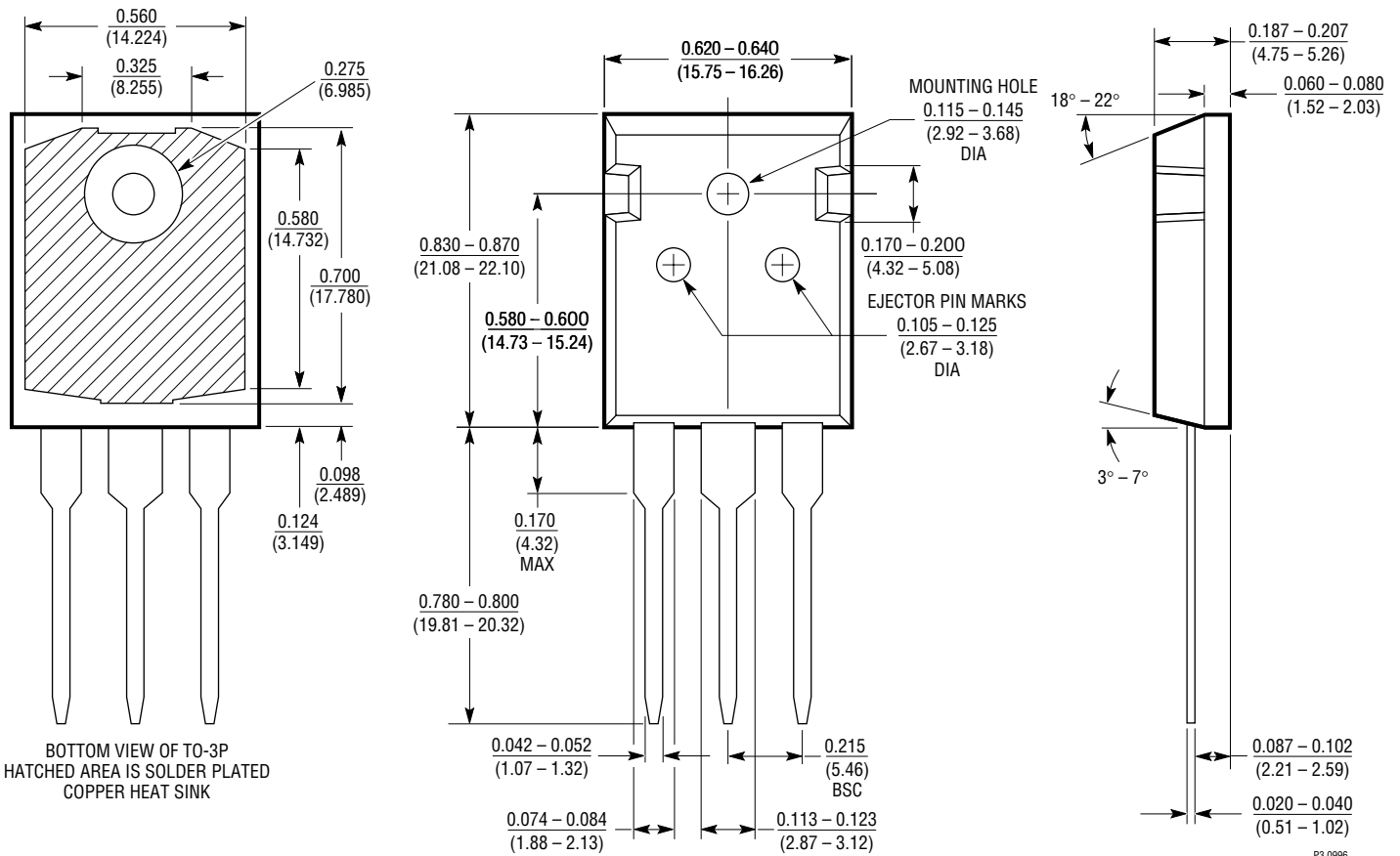

BOTTOM VIEW OF TO-3P  
 HATCHED AREA IS SOLDER PLATED  
 COPPER HEAT SINK

P3 0996

# LT1033

## RELATED PARTS

PART NUMBER	DESCRIPTION	COMMENTS
LT1120	125mA Low Dropout Regulator with 20 $\mu$ A I <sub>Q</sub>	Includes 2.5V Reference and Comparator
LT1121	150mA Micropower Low Dropout Regulator	30 $\mu$ A I <sub>Q</sub> , SOT-223 Package
LT1129	700mA Micropower Low Dropout Regulator	50 $\mu$ A Quiescent Current
LT1175	500mA Negative Low Dropout Micropower Regulator	45 $\mu$ A I <sub>Q</sub> , 0.26V Dropout Voltage, SOT-223 Package
LT1374	4.5A, 500kHz Step-Down Converter	4.5A, 0.07 $\Omega$ Internal Switch, SO-8 Package
LT1521	300mA Low Dropout Micropower Regulator with Shutdown	15 $\mu$ A I <sub>Q</sub> , Reverse Battery Protection
LT1529	3A Low Dropout Regulator with 50 $\mu$ A I <sub>Q</sub>	500mV Dropout Voltage
LT1573	UltraFast™ Transient Response Low Dropout Regulator	Drives External PNP
LT1575	UltraFast Transient Response Low Dropout Regulator	Drives External N-Channel MOSFET
LT1735	Synchronous Step-Down Converter	High Efficiency, OPTI-LOOP® Compensation
LT1761 Series	100mA, Low Noise, Low Dropout Micropower Regulators in SOT-23	20 $\mu$ A Quiescent Current, 20 $\mu$ V <sub>RMS</sub> Noise, SOT-23 Package
LT1762 Series	150mA, Low Noise, LDO Micropower Regulators	25 $\mu$ A Quiescent Current, 20 $\mu$ V <sub>RMS</sub> Noise, MSOP Package
LT1763 Series	500mA, Low Noise, LDO Micropower Regulators	30 $\mu$ A Quiescent Current, 20 $\mu$ V <sub>RMS</sub> Noise, SO-8 Package
LT1764	3A, Low Noise, Fast Transient Response LDO	40 $\mu$ V <sub>RMS</sub> Noise
LT1962	300mA, Low Noise, LDO Micropower Regulator	20 $\mu$ V <sub>RMS</sub> Noise, MSOP Package
LT1963	1.5A, Low Noise, Fast Transient Response LDO	40 $\mu$ V <sub>RMS</sub> Noise, SOT-223 Package

OPTI-LOOP is a registered trademark of Linear Technology Corporation. UltraFast is a trademark of Linear Technology Corporation.