



FEATURES

- Generates + and - from Single Input
- Up to $\pm 18V$ Output
- Only Needs Four $1\mu F$ Capacitors
- No Inductors
- 10mA Output Current Minimum
- Operates Down to 4V
- No Latchup
- 8-Pin Minidip

APPLICATIONS

- Line Drivers
- Op Amp Suppliers
- Battery Splitters
- RS232 Power

DESCRIPTION

The LT[®]1026 is a switched capacitor voltage doubler and inverter on a single monolithic die. Capable of operating from a 4V to 10V input, it provides $\pm 7V$ to $\pm 18V$ output. Output currents of over 10mA are available. Two charge pumps first double the input voltage then invert the doubled voltage. Manufactured in bipolar technology, the LT1026 is not susceptible to latchup and generates up to 36V.

The LT1026 offers a convenient way of generating additional system voltages without using inductors. Powering interface circuits, op amps or data acquisition circuitry off logic supplies is simplified.

LT, LTC and LT are registered trademarks of Linear Technology Corporation.

TYPICAL APPLICATION

Voltage Doubler and Inverter

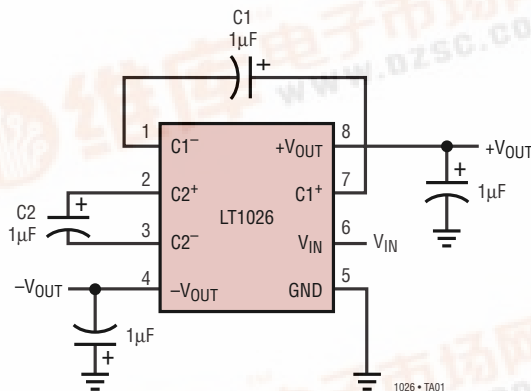

Output Voltage

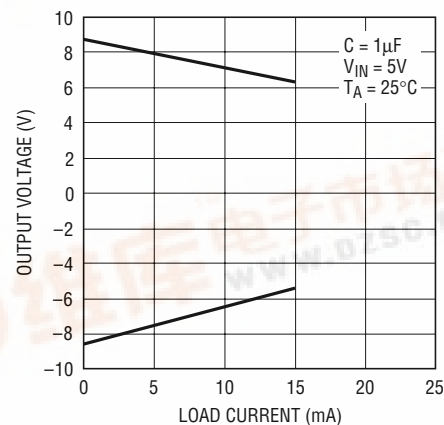

LT1026

ABSOLUTE MAXIMUM RATINGS (Note 1)

Supply Voltage	10V	Operating Temperature Range	
V ⁺	20V	LT1026C	0°C to 70°C
V ⁻	-20V	LT1026I	-40°C to 85°C
Short-Circuit Duration	10 sec	LT1026M (OBSOLETE)	-55°C to 125°C
		Lead Temperature (Soldering, 10 sec)	300°C

PACKAGE/ORDER INFORMATION

<p>H PACKAGE 8-LEAD TO-5 METAL CAN T_{JMAX} = 150°C, θ_{JA} = 150°C/W</p>	<p>J8 PACKAGE 8-LEAD CERDIP T_{JMAX} = 150°C, θ_{JA} = 150°C/W</p>	<p>N8 PACKAGE 8-LEAD PDIP S8 PACKAGE 8-LEAD PLASTIC SO T_{JMAX} = 150°C, θ_{JA} = 100°C/W (N8) T_{JMAX} = 150°C, θ_{JA} = 150°C/W (S8)</p>	
ORDER PART NUMBER	ORDER PART NUMBER	ORDER PART NUMBER	S8 PART MARKING
LT1026CH LT1026MH	LT1026CJ8 LT1026MJ8	LT1026CN8 LT1026CS8 LT1026IS8	1026 1026I
OBSOLETE PACKAGES Consider the N8 or S8 Packages for Alternate Source			

Consult LTC Marketing for parts specified with wider operating temperature ranges.

ELECTRICAL CHARACTERISTICS

The ● denotes the specifications which apply over the full operating temperature range, otherwise specifications are at T_A = 25°C.

PARAMETERS	CONDITIONS				MIN	TYP	MAX	UNITS
Output Voltage	V _{IN} = 4V (Note 2)	I _L = 0mA	Positive	●	6.5	7		V
		I _L = 0mA	Negative	●	-6	-6.7		V
		I _L = 10mA	Positive	●	5.25	5.7		V
		I _L = -10mA	Negative	●	-4.5	-5		V
	V _{IN} = 5V	I _L = 15mA	Positive	●	6.25	7		V
		I _L = -15mA	Negative	●	-5.5	-6.2		V
	V _{IN} = 10V	I _L = 0mA	Positive	●	18	18.5		V
		I _L = 0mA	Negative	●	-17.7	-18		V
		I _L = 10mA	Positive	●	16	17.6		V
		I _L = -10mA	Negative	●	-15.3	-17		V
		I _L = 15mA	Positive	●	15.25	17		V
		I _L = -15mA	Negative	●	-14.5	-16.5		V
	V _{IN} = 5V	I _L = 10mA, -10mA	Positive	●	6.25	7.2		V
			Negative	●	-5.5	-6.5		V
V _{IN} = 10V	I _L = 10mA, -10mA	Positive	●	15	16.8		V	
		Negative	●	-14.25	-15.75		V	

ELECTRICAL CHARACTERISTICS The ● denotes the specifications which apply over the full operating temperature range, otherwise specifications are at $T_A = 25^\circ\text{C}$.

PARAMETERS	CONDITIONS		MIN	TYP	MAX	UNITS
Supply Current	$V_{IN} = 4\text{V}$ $I_L = 0\text{mA}$	●		7	12.5	mA
	$V_{IN} = 10\text{V}$ $I_L = 0\text{mA}$	●		15	30	mA

Note 1: Absolute Maximum Ratings are those values beyond which the life of a device may be impaired.

Note 2: $V_{IN\text{ min}} = -4.5$ for $T_A \leq 40^\circ\text{C}$

TYPICAL PERFORMANCE CHARACTERISTICS

Load Regulation (Both Outputs Loaded)

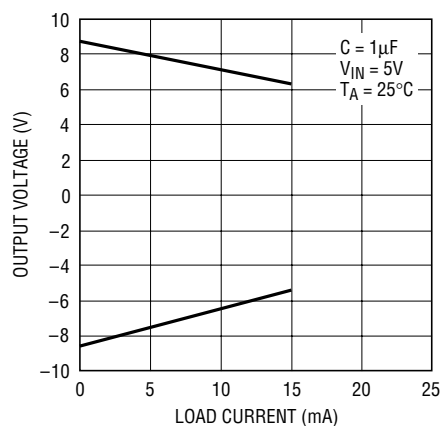

LT1026 • TPC01

Load Regulation for Positive Loading

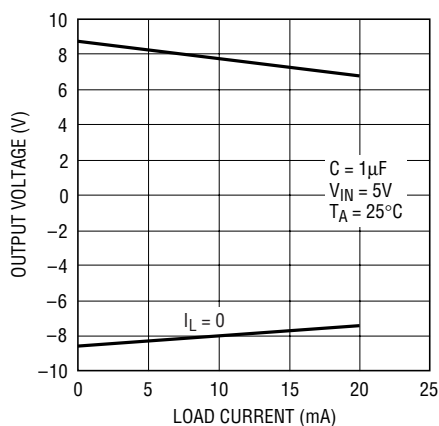

LT1026 • TPC02

Load Regulation for Negative Loading

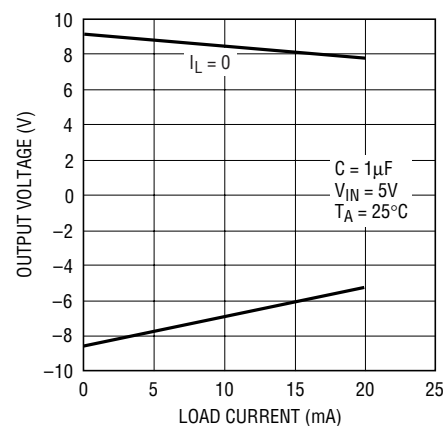

LT1026 • TPC03

Supply Current

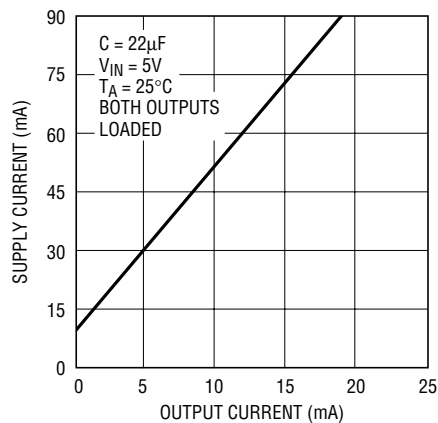

LT1026 • TPC04

Supply Current

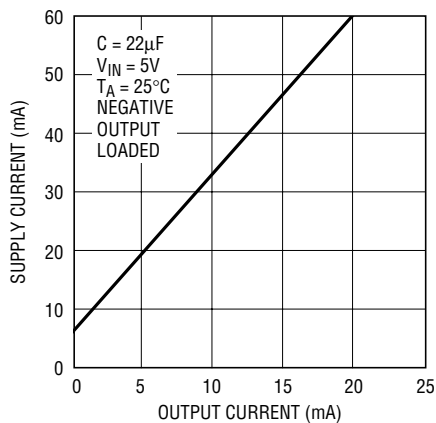

LT1026 • TPC05

Supply Current

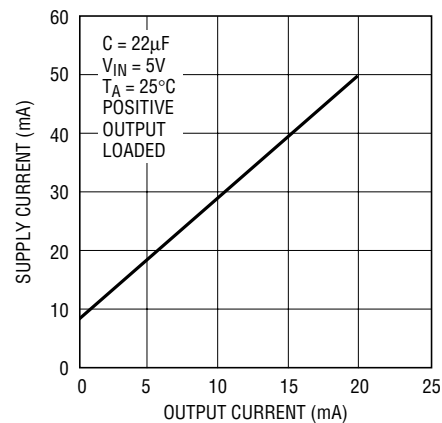

LT1026 • TPC06

TYPICAL PERFORMANCE CHARACTERISTICS

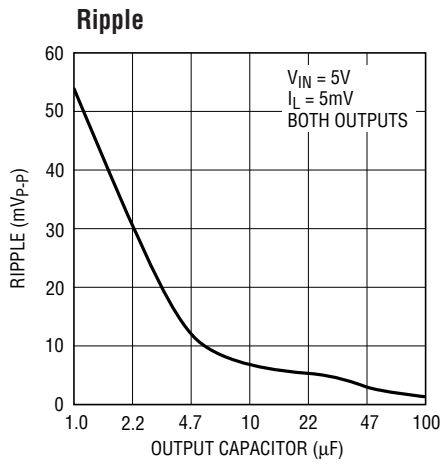

1026 • TPC07

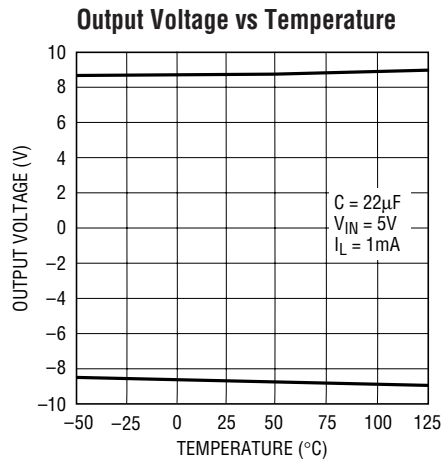

LT1026 • TPC08

APPLICATIONS INFORMATION

The LT1026 is a nonregulating voltage converter that converts a single input voltage into both a positive and negative output at up to 15mA. A positive input voltage is first doubled and then the doubled voltage is inverted. The voltage output level is dependent on both the input voltage and the output loading. The total output current available depends on the individual loading of the outputs since loading on one output affects the load and the voltage of the other.

Only four external components are needed for operation. Two charge pump capacitors and two output storage capacitors. Nominal value for these capacitors is 1μF, but the LT1026 will operate (with reduced performance) down to 0.1μF. Higher value capacitors (22μF) will reduce ripple and slightly lower output impedance. For higher output currents the outputs of several converters may be paralleled with common output capacitors.

The substrate diodes are an inherent part of the IC, and must always be reversed biased to isolate the individual transistors. In the LT1026 the substrate is tied to the negative output. If the negative output is not used, such as when only the voltage doubler output is needed, $-V_{OUT}$ must be tied to ground so the substrate diodes are properly biased. The substrate diodes must never become forward biased even during overload conditions. For example, pulling $-V_{OUT}$ positive with respect to ground can forward bias the substrate diodes. Clamping the substrate to ground with an external diode would be needed to ensure proper operation and prevent the substrate from carrying any current.

No overload protection is included on the LT1026. Neither output is damaged by momentary shorts, but during sustained shorts the resulting high current flow will overheat the IC.

TYPICAL APPLICATIONS

Positive to Negative Converter

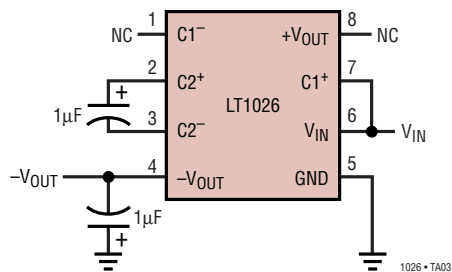

Voltage Doubler

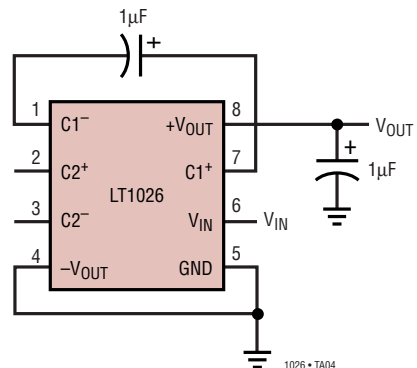

Standard Configuration Voltage Doubler and Inverter

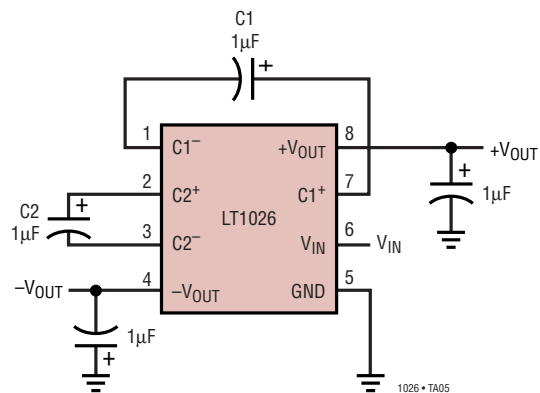

Voltage Quadrupler

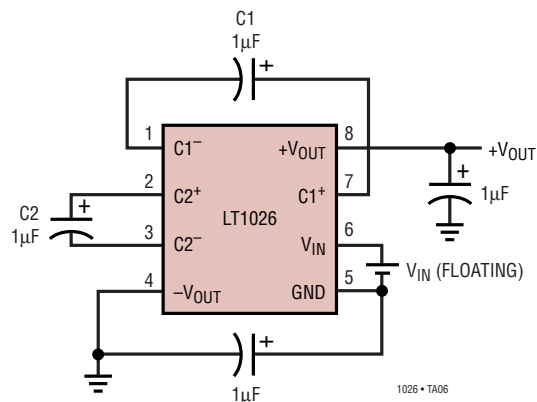

Parallel Converters for Higher Output Current and Lower Output Impedance

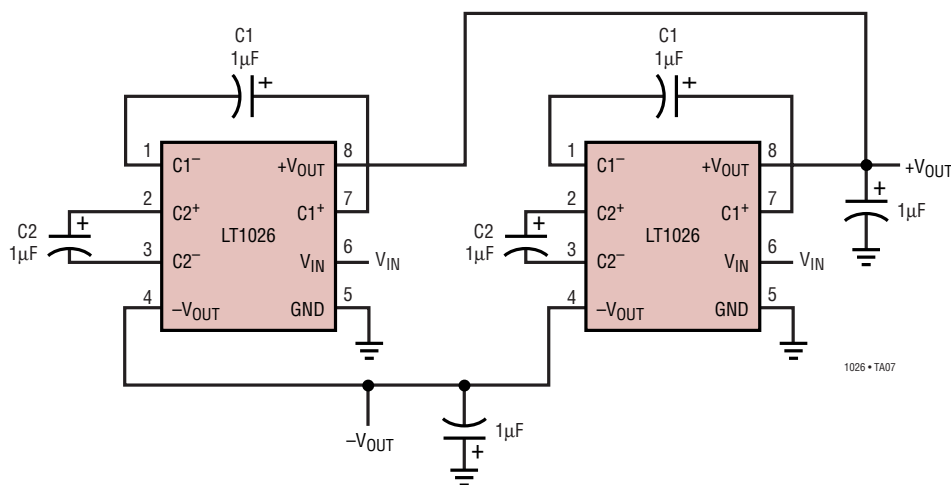

TYPICAL APPLICATIONS

5V Powered RS232 Line Driver

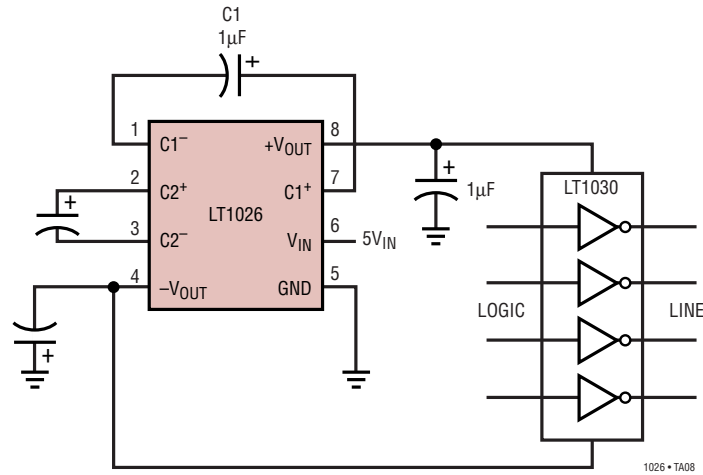

PACKAGE DESCRIPTION

H Package
8-Lead TO-5 Metal Can (.230 Inch PCD)
 (Reference LTC DWG # 05-08-1321)

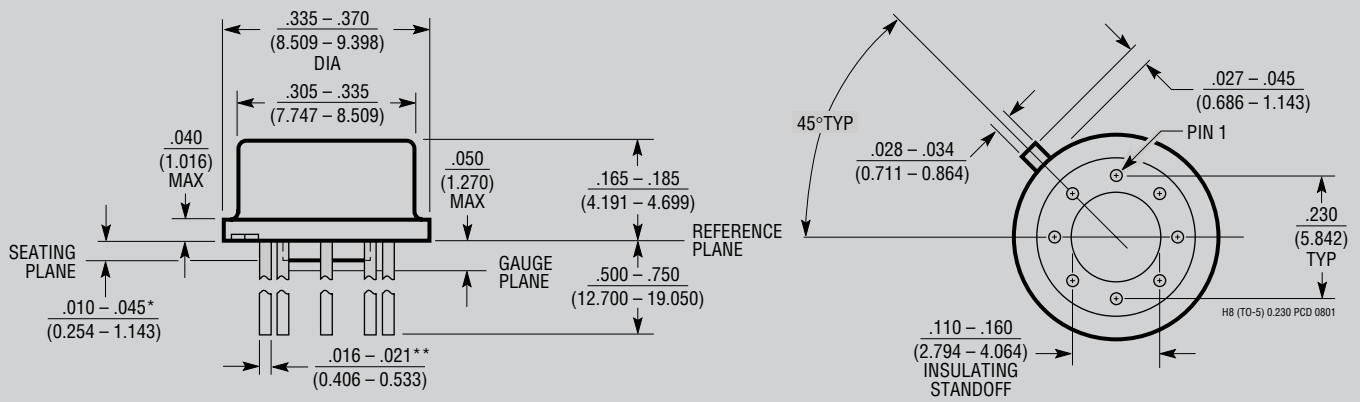

*LEAD DIAMETER IS UNCONTROLLED BETWEEN THE REFERENCE PLANE AND THE SEATING PLANE
 **FOR SOLDER DIP LEAD FINISH, LEAD DIAMETER IS $\frac{.016 - .024}{(0.406 - 0.610)}$

OBSOLETE PACKAGE

PACKAGE DESCRIPTION

J8 Package 8-Lead Cerdip (Narrow .300 Inch, Hermetic) (Reference LTC DWG # 05-08-1110)

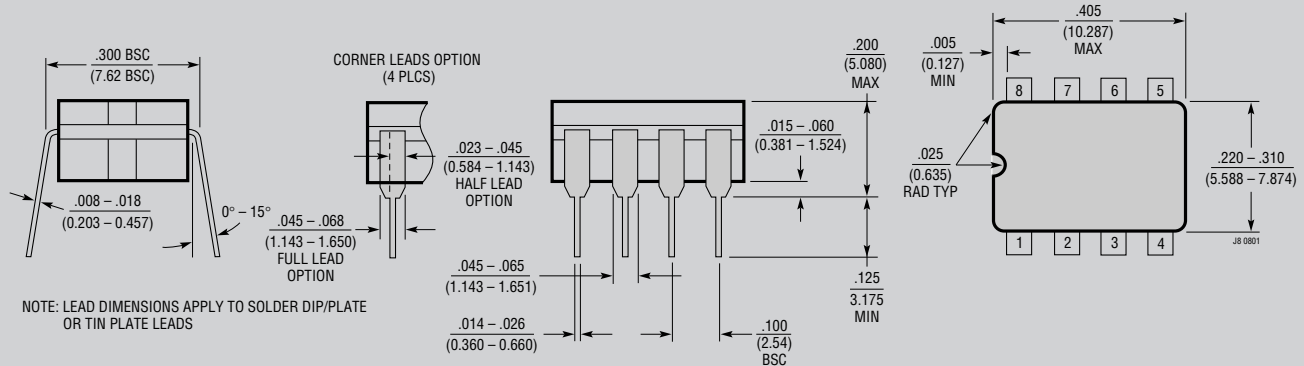

OBSOLETE PACKAGE

N8 Package 8-Lead PDIP (Narrow .300 Inch) (Reference LTC DWG # 05-08-1510)

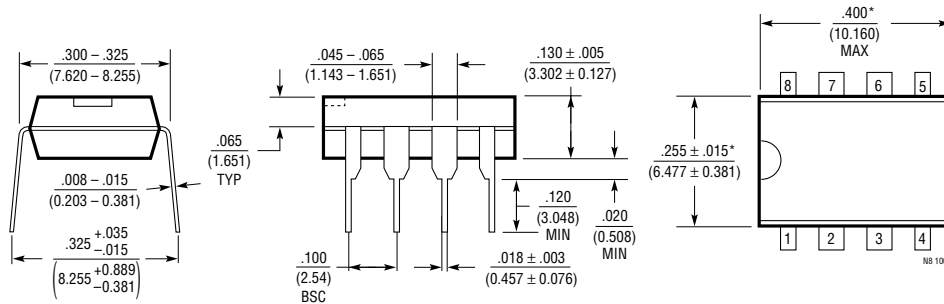

NOTE:
1. DIMENSIONS ARE $\frac{\text{INCHES}}{\text{MILLIMETERS}}$
*THESE DIMENSIONS DO NOT INCLUDE MOLD FLASH OR PROTRUSIONS.
MOLD FLASH OR PROTRUSIONS SHALL NOT EXCEED .010 INCH (0.254mm)

S8 Package 8-Lead Plastic Small Outline (Narrow 0.150) (LTC DWG # 05-08-1610)

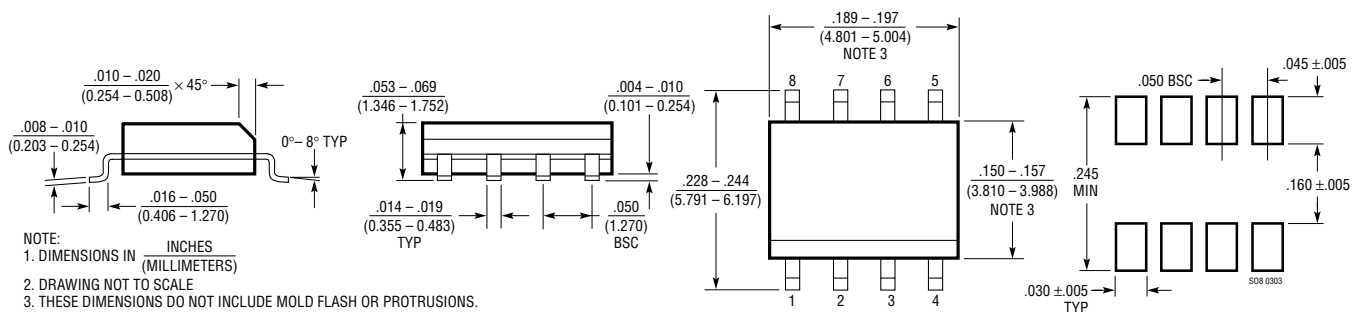

RECOMMENDED SOLDER PAD LAYOUT

LT1026

TYPICAL APPLICATION

Regulated Converter

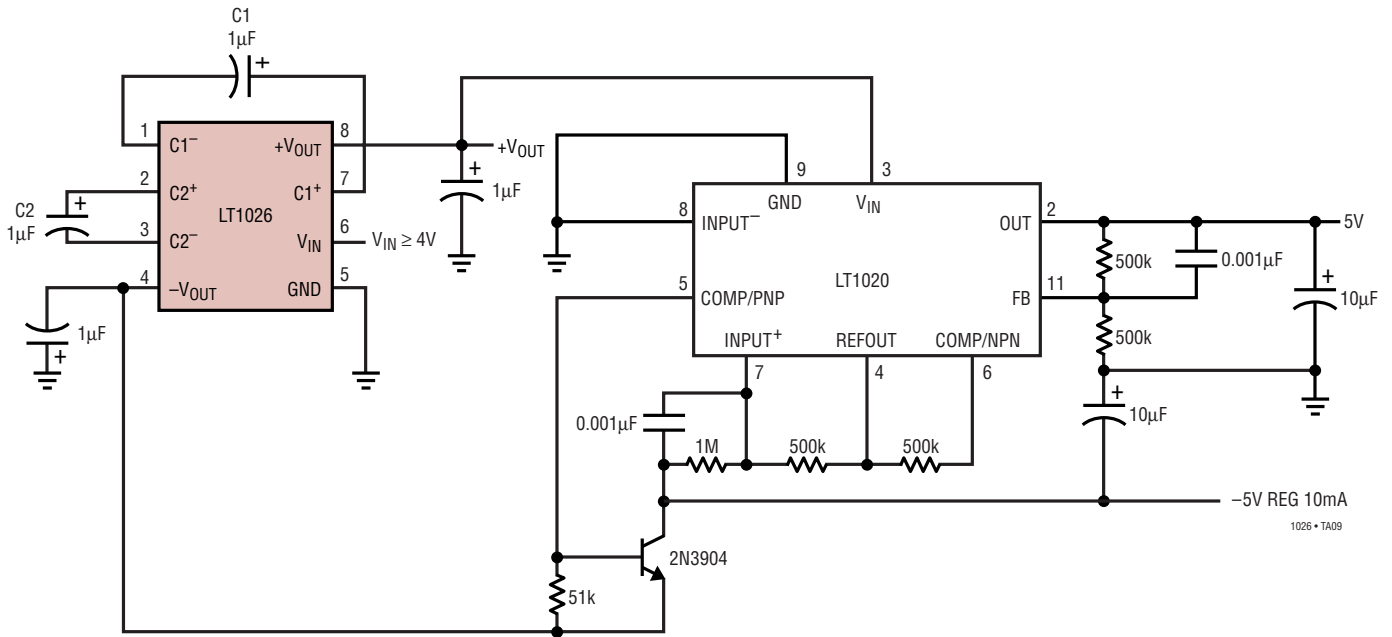

RELATED PARTS

PART NUMBER	DESCRIPTION	COMMENTS
LT1044	Switched Capacitor Voltage Converter	Can be Used as Inverter/Doubler/Divider or a Multiplier, $V_{IN} = 1.5V$ to $9V$, $I_Q = 60\mu A$, SO-8
LT1054/LT1054L	Switched Capacitors Voltage Converters with Regulator	I_{OUT} to $100mA/125mA$, $V_{IN} = 3.5V$ to $15V$, Inverter, Neg/Pos Doubler
LTC1517-5	Micropower, Regulated 5V In SOT-23	Ultralow Power: $I_{CC} = 6\mu A$ Typical, Small 5-Pin SOT-23
LTC1550/LTC1551	Low Noise, Switched Capacitor Regulator Voltage Inverter	$< 1mVp-p$ Typical Output Ripple, $900kHz$, $I_{OUT} = 10mA$
LTC1555/LTC1556	SIM Power Supply and Level Translator	Step-Up/Step-Down Generates 5V, Input Voltage Range: $2.7V$ to $10V$, $> 10kV$ ESD, Short-Circuit and Overtemp Protection