



LT1024

Dual, Matched Picoampere, Microvolt Input, Low Noise Op Amp

FEATURES

- *Guaranteed* Offset Voltage: 50µV Max
- *Guaranteed* Bias Current:
 - 25°C: 120pA Max
 - 55°C to 125°C: 700pA Max
- *Guaranteed* Drift: 1.5µV/°C Max
- Low Noise, 0.1Hz to 10Hz: 0.5µV_{P-P}
- *Guaranteed* Supply Current: 600µA Max
- *Guaranteed* CMRR: 112dB Min
- *Guaranteed* PSRR: 112dB Min
- *Guaranteed* Voltage Gain with 5mA Load Current
- *Guaranteed* Matching Characteristics

APPLICATIONS

- Strain Gauge Signal Conditioner
- Dual Limit Precision Threshold Detection
- Charge Integrators
- Wide Dynamic Range Logarithmic Amplifiers
- Light Meters
- Low Frequency Active Filters
- Standard Cell Buffers
- Thermocouple Amplifiers

LT, LTC and LT are registered trademarks of Linear Technology Corporation.

DESCRIPTION

The LT[®]1024 dual, matched internally compensated universal precision operational amplifier can be used in practically all precision applications requiring multiple op amps. The LT1024 combines picoampere bias currents (which are maintained over the full -55°C to 125°C temperature range), microvolt offset voltage (and low drift with time and temperature), low voltage and current noise and low power dissipation. Extremely high common mode and power supply rejection ratios, practically immeasurable warm-up drift, and the ability to deliver 5mA load current with a voltage gain of a million, round out the LT1024's superb precision specifications.

Tight matching is guaranteed on offset voltage, noninverting bias currents and common mode and power supply rejections.

The all-around excellence of the LT1024 eliminates the necessity of the time-consuming error analysis procedure of precision system design in many dual applications; the LT1024 can be stocked as the universal dual op amp in the 14-pin DIP configuration.

For a single op amp with similar specifications, see the LT1012 data sheet; for a single supply dual precision op amp in the 8-pin configuration, see the LT1013 data sheet.

TYPICAL APPLICATION

Two Op Amp Instrumentation Amplifier

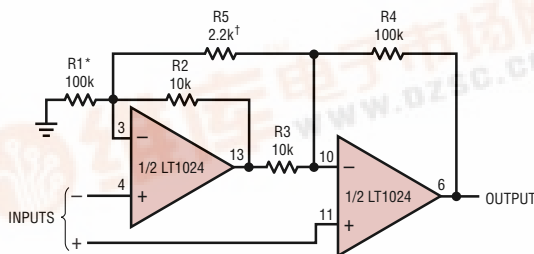

$$GAIN = \frac{R4}{R3} \left[1 + \frac{1}{2} \left(\frac{R2 + R3}{R1} \right) + \frac{R2 + R3}{R5} \right] \approx 100$$

TYPICAL PERFORMANCE:
 OFFSET VOLTAGE = 20µV
 BIAS CURRENT = ±30pA
 OFFSET CURRENT = 30pA

Input Bias Current vs Temperature

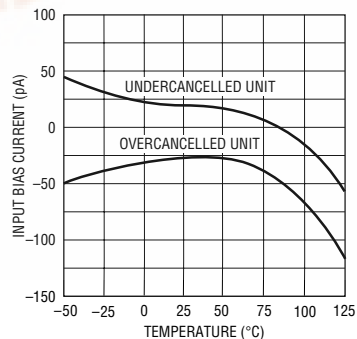

LT1024 • TA02

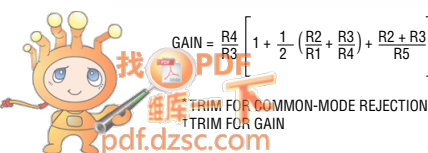

LT1024

ABSOLUTE MAXIMUM RATINGS

(Note 1)

Supply Voltage	±20V
Differential Input Current (Note 2)	±10mA
Input Voltage	±20V
Output Short Circuit Duration	Indefinite
Operating Temperature Range	
LT1024AM/LT1024M (OBSOLETE).....	-55°C to 125°C
LT1024AC/LT1024C	0°C to 70°C
Storage Temperature Range	-65°C to 150°C
Lead Temperature (Soldering, 10 sec).....	300°C

PACKAGE/ORDER INFORMATION

<p>TOP VIEW</p> <p>NULL (A) 1, 2 -IN (A) 3 +IN (A) 4 V⁻ (B) 5 OUT (B) 6 V⁺ (B) 7</p> <p>14 V⁺ (A) 13 OUT (A) 12 V⁻ (A) 11 +IN (B) 10 -IN (B) 9 NULL (B) 8 NULL (B)</p> <p>N PACKAGE 14-PIN PDIP</p> <p>T_{JMAX} = 100°C, θ_{JA} = 100°C/W, θ_{JC} = 60°C/W (N)</p> <p>NOTE: DEVICE MAY BE OPERATED EVEN IF INSERTION IS REVERSED; THIS IS DUE TO INHERENT SYMMETRY OF PIN LOCATIONS OF AMPLIFIERS A AND B (NOTE 3)</p>	ORDER PART NUMBER
	LT1024ACN LT1024CN
<p>D PACKAGE 14-PIN SIDE BRAZED (HERMETIC)</p> <p>T_{JMAX} = 150°C, θ_{JA} = 100°C/W, θ_{JC} = 60°C/W (D)</p>	ORDER PART NUMBER
	LT1024AMD LT1024MD
<p>OBSOLETE PACKAGE</p> <p>Consider the N14 Package as an Alternate Source</p>	

Consult LTC Marketing for parts specified with wider operating temperature ranges.

ELECTRICAL CHARACTERISTICS

Individual Amplifiers. V_S = ±15V, V_{CM} = 0V, T_A = 25°C unless otherwise noted.

SYMBOL	PARAMETER	CONDITIONS	LT1024AM/LT1024AC			LT1024M/LT1024C			UNITS	
			MIN	TYP	MAX	MIN	TYP	MAX		
V _{OS}	Input Offset Voltage			15	50		20	100	μV	
	Long Term Input Offset Voltage Stability			0.3			0.3		μV/month	
I _{OS}	Input Offset Current			20	100		25	180	pA	
I _B	Input Bias Current			±25	±120		±30	±200	pA	
e _n	Input Noise Voltage	0.1Hz to 10Hz		0.5			0.5		μV _{P-P}	
e _n	Input Noise Voltage Density	f ₀ = 10Hz (Note 4)		17	33		17	33	nV/√Hz	
		f ₀ = 1000Hz (Note 4)		14	24		14	24	nV/√Hz	
i _n	Input Noise Current Density	f ₀ = 10Hz		20			20		fA/√Hz	
A _{VOL}	Large-Signal Voltage Gain	V _{OUT} = ±12V, R _L ≥ 10kΩ	250	2000		180	2000		V/mV	
		V _{OUT} = ±10V, R _L ≥ 2kΩ	150	1000		100	1000		V/mV	
CMRR	Common Mode Rejection Ratio	V _{CM} = ±13.5V	112	132		108	132		dB	
PSRR	Power Supply Rejection Ratio	V _S = ±2V to ±20V	112	132		108	132		dB	
		Input Voltage Range		±13.5	±14.0		±13.5	±14.0		V
V _{OUT}	Output Voltage Swing	R _L = 10kΩ		±13	±14		±13	±14		V
		Slew Rate		0.1	0.2		0.1	0.2		V/μs
I _S	Supply Current per Amplifier			380	600		380	700	μA	

ELECTRICAL CHARACTERISTICS

Matching Specifications. $V_S = \pm 15V$, $V_{CM} = 0V$, $T_A = 25^\circ C$ unless otherwise noted.

SYMBOL	PARAMETER	CONDITIONS	LT1024AM/LT1024AC			LT1024M /LT1024C			UNITS
			MIN	TYP	MAX	MIN	TYP	MAX	
	Input Offset Voltage Match			20	75		25	150	μV
I_B^+	Average Noninverting Bias Current			± 30	± 150		± 40	± 250	μA
I_{OS}^+	Noninverting Offset Current			30	150		30	300	μA
$\Delta CMRR$	Common Mode Rejection Ratio Match	$V_{CM} = \pm 13.5V$	110	132		106	132		dB
$\Delta PSRR$	Power Supply Rejection Ratio Match	$V_S = \pm 2V$ to $20V$	110	132		106	132		dB
	Channel Separation	$f \leq 10Hz$ (Note 4)	134	150		134	150		dB

Individual Amplifiers. The ● denotes the specifications which apply over the full operating temperature range of $0^\circ C \leq T_A = 70^\circ C$ for the LT1024AC and LT1024C; $-55^\circ C \leq T_A \leq 125^\circ C$ for the LT1024AM and LT1024M. $V_S = \pm 15V$, $V_{CM} = 0V$, unless otherwise noted.

SYMBOL	PARAMETER	CONDITIONS		LT1024AM/LT1024AC			LT1024M/LT1024C			UNITS
				MIN	TYP	MAX	MIN	TYP	MAX	
V_{OS}	Input Offset Voltage	$0^\circ C$ to $70^\circ C$	●		30	120		35	200	μV
		$-55^\circ C$ to $125^\circ C$	●		40	200		50	300	μV
	Average Temperature Coefficient of Input Offset Voltage		●		0.25	1.5		0.3	2.0	$\mu V/^\circ C$
I_{OS}	Input Offset Current	$0^\circ C$ to $70^\circ C$	●		40	250		50	300	μA
		$-55^\circ C$ to $125^\circ C$	●		80	350		100	500	μA
	Average Temperature Coefficient of Input Offset Current		●		0.5	2.5		0.7	3	$\mu A/^\circ C$
I_B	Input Bias Current	$0^\circ C$ to $70^\circ C$	●		± 40	± 250		± 50	± 400	μA
		$-55^\circ C$ to $125^\circ C$	●		± 100	± 700		± 200	± 1300	μA
	Average Temperature Coefficient of Input Bias Current	$0^\circ C$ to $70^\circ C$	●		0.4	3		0.5	4	$\mu A/^\circ C$
		$-55^\circ C$ to $125^\circ C$	●		1	6		2	12	$\mu A/^\circ C$
A_{VOL}	Large-Signal Voltage Gain	$V_{OUT} = \pm 12V$, $R_L \geq 10k\Omega$	●	150	1000		150	1000		V/mV
		$V_{OUT} = \pm 10V$, $R_L \geq 2k\Omega$	●	100	600		100	600		V/mV
$CMRR$	Common Mode Rejection Ratio	$V_{CM} = \pm 13.5V$	●	108	128		106	128		dB
$PSRR$	Power Supply Rejection Ratio	$V_S = \pm 2.5V$ to $\pm 18V$	●	108	128		106	128		dB
	Input Voltage Range		●	± 13.5			± 13.5			V
V_{OUT}	Output Voltage Swing	$R_L = 10k\Omega$	●	± 13	± 14		± 13	± 14		V
I_S	Supply Current		●		400	800		400	900	μA

LT1024

ELECTRICAL CHARACTERISTICS

Matching Specifications. The ● denotes the specifications which apply over the temperature range of $0^{\circ}\text{C} \leq T_A = 70^{\circ}\text{C}$ for the LT1024AC and LT1024C; $-55^{\circ}\text{C} \leq T_A \leq 125^{\circ}\text{C}$ for the LT1024AM and LT1024M, $V_S = \pm 15\text{V}$, $V_{CM} = 0\text{V}$ unless otherwise noted.

SYMBOL	PARAMETER	CONDITIONS		LT1024AM/LT1024AC			LT1024M/LT1024C			UNITS
				MIN	TYP	MAX	MIN	TYP	MAX	
	Input Offset Voltage Match	0°C to 70°C -55°C to 125°C	● ●		35 50	170 280	45 70	300 500	μV μV	
	Input Offset Voltage Tracking		●		0.3	2	0.4	3.5	$\mu\text{V}/^{\circ}\text{C}$	
I_B^+	Average Noninverting Bias Current	0°C to 70°C -55°C to 125°C	● ●		± 40 ± 100	± 300 ± 800	± 50 ± 200	± 500 ± 1400	pA pA	
I_{OS}^+	Noninverting Offset Current	0°C to 70°C -55°C to 125°C	● ●		40 80	300 800	50 150	500 1500	pA pA	
ΔCMRR	Common Mode Rejection Ratio Match	$V_{CM} = \pm 13.5\text{V}$	●	106	128		104	128	dB	
ΔPSRR	Power Supply Rejection Ratio Match	$V_S = \pm 2.5\text{V}$ to $\pm 18\text{V}$	●	106	128		104	128	dB	

Note 1: Absolute Maximum Ratings are those values beyond which the life of a device may be impaired.

Note 2: Differential input voltages greater than 1V will cause excessive current to flow through the input protection diodes unless limiting resistance is used.

Note 3: The V^+ supply terminals are completely independent and may be powered by separate supplies if desired (this approach, however, would sacrifice the advantages of the power supply rejection ratio matching). The V^- supply terminals are both connected to the common substrate and must be tied to the same voltage. Both V^- pins should be used.

Note 4: This parameter is tested on a sample basis only.

Optional Offset Nulling Circuit

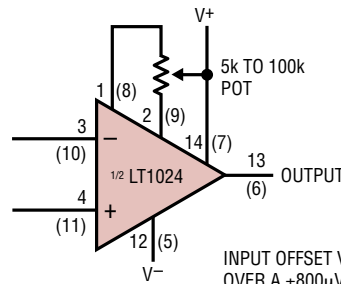

INPUT OFFSET VOLTAGE CAN BE ADJUSTED OVER A $\pm 800\mu\text{V}$ RANGE WITH A 5k TO 100k POTENTIOMETER

LT1024 • EC01

TYPICAL PERFORMANCE CHARACTERISTICS

Offset Voltage vs Source Resistance (Balanced or Unbalanced)

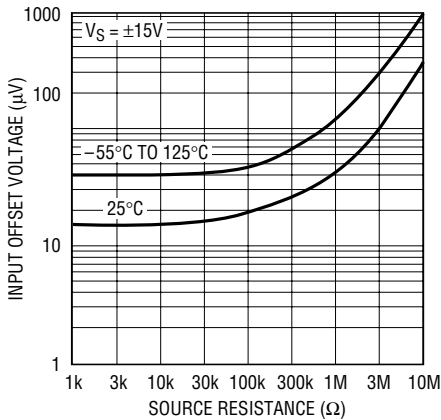

LT1024 • TPC01

Input Offset Current vs Temperature

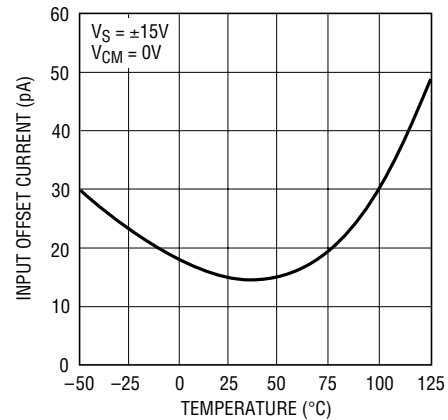

LT1024 • TPC02

TYPICAL PERFORMANCE CHARACTERISTICS

Input Bias Current Over Common Mode Range

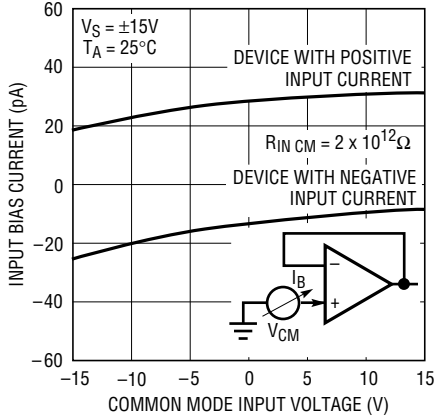

LT1024 • TPC03

Warm-Up Drift

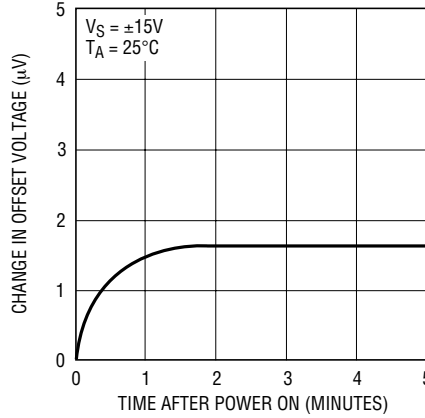

LT1024 • TPC04

Offset Voltage Drift and Tracking with Temperatures of Representative Units

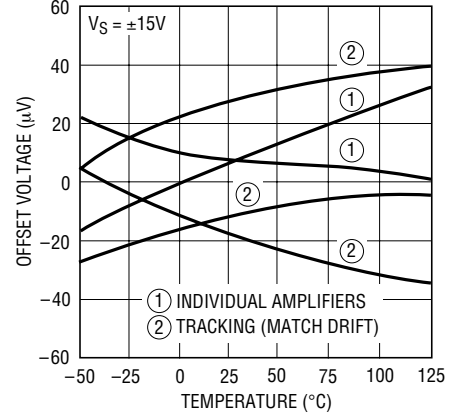

LT1024 • TPC05

Supply Current vs Supply Voltage per Amplifier

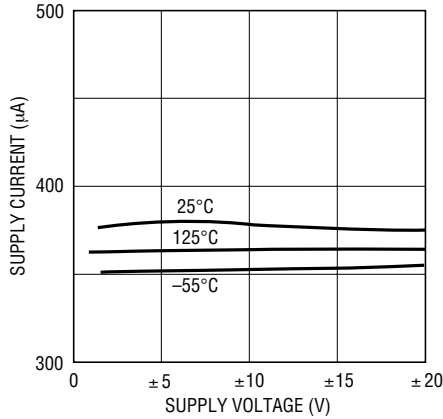

LT1024 • TPC06

0.1Hz to 10Hz Noise

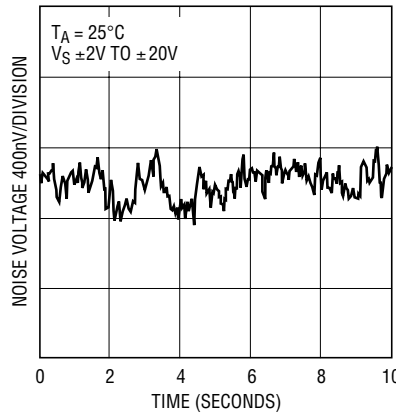

LT1024 • TPC07

Noise Spectrum

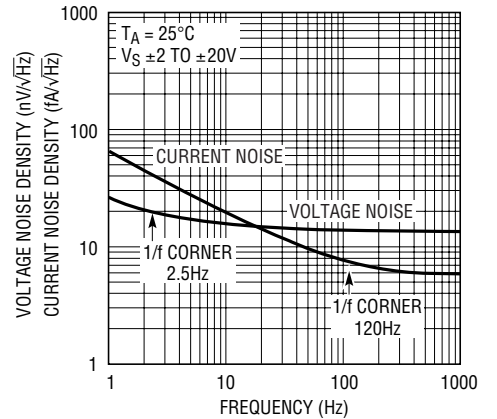

LT1024 • TPC08

Total Noise vs Source Resistance

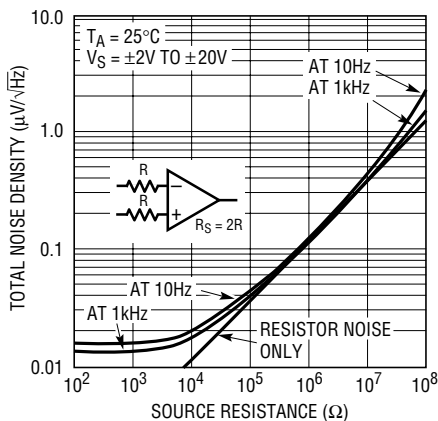

LT1024 • TPC09

Common Mode Rejection and CMRR Match vs Frequency

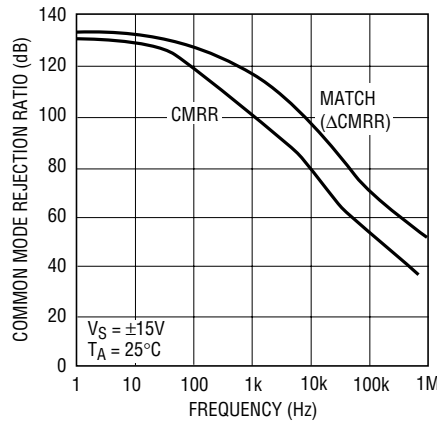

LT1024 • TPC10

Power Supply Rejection vs Frequency

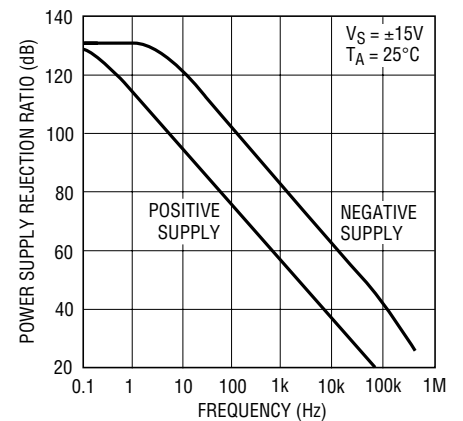

LT1024 • TPC11

TYPICAL PERFORMANCE CHARACTERISTICS

Channel Separation vs Frequency

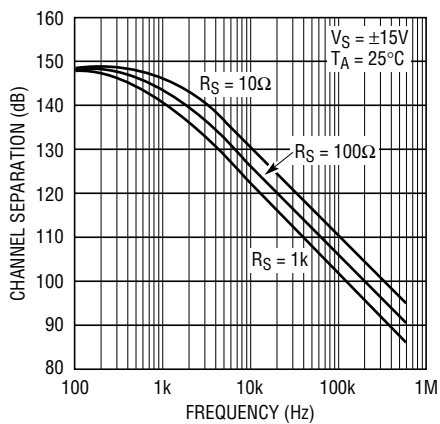

LT1024 • TPC12

Voltage Gain vs Frequency

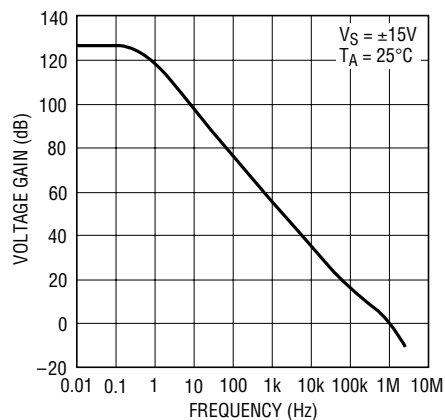

LT1024 • TPC13

Gain, Phase Shift vs Frequency

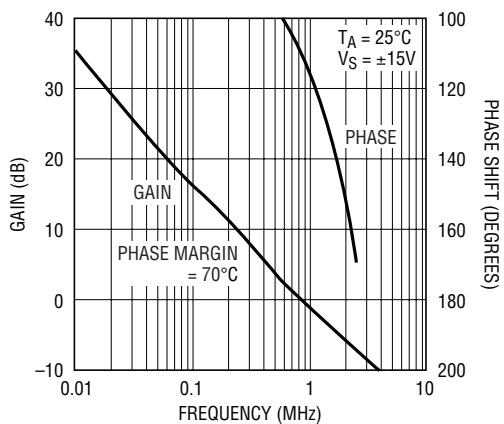

LT1024 • TPC14

Voltage Gain vs Load Resistance

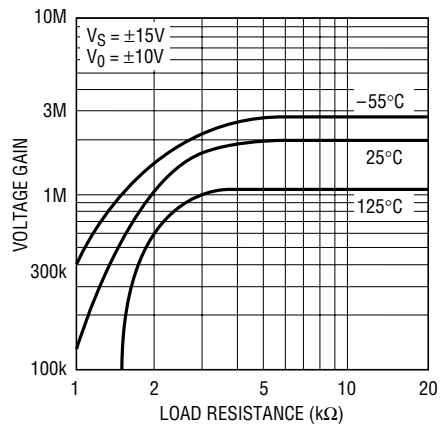

LT1024 • TPC15

Small-Signal Transient Response

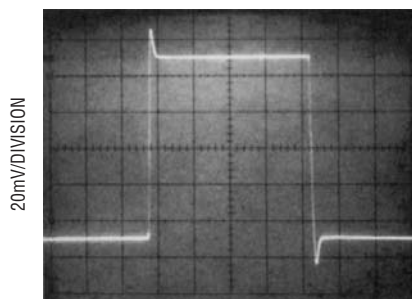

$A_V = +1$
 $C_{LOAD} = 100pF$

Small-Signal Transient Response

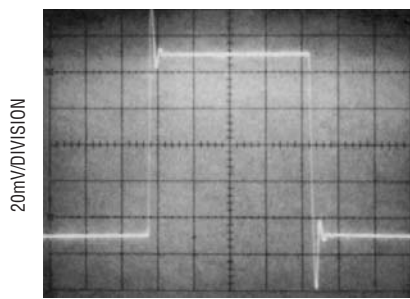

$A_V = +1$
 $C_{LOAD} = 1000pF$

Large-Signal Transient Response

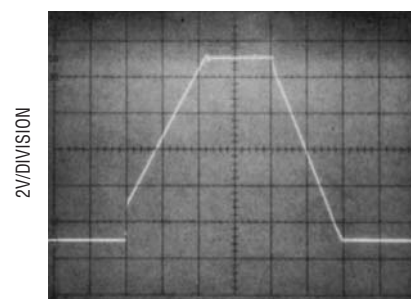

$A_V = +1$
 $20\mu s/DIV$

APPLICATIONS INFORMATION

The LT1024 may be inserted directly into OP-10, OP-207 or OP227 sockets with or without removal of external nulling components.

The LT1024 is specified over a wide range of power supply voltages from $\pm 2V$ to $\pm 18V$. Operation with lower supplies is possible down to $\pm 1.2V$ (two NiCad batteries).

Advantages of Matched Dual Op Amps

In many applications, the performance of a system depends on the matching between two operational amplifiers rather than the individual characteristics of the two op amps. Two or three op amp instrumentation amplifiers, tracking voltage references, and low drift active filters are some of the circuits requiring matching between two op amps.

The well-known triple op amp configuration illustrates these concepts. Output offset is a function of the difference between the offsets of the two halves of the LT1024. This error cancellation principle holds for a considerable number of input-referred parameters in addition to offset voltage and its drift with temperature. Input bias current will be the average of the two noninverting input currents (I_B^+). The difference between

these two currents (I_{OS}^+) is the offset current of the instrumentation amplifier. Common mode and power supply rejections will be dependent only on the match between the two amplifiers (assuming perfect resistor matching).

The concepts of common mode and power supply rejection ratio match ($\Delta CMRR$ and $\Delta PSRR$) are best demonstrated with a numerical example:

Assume $CMRR_A = +1.0\mu V/V$ or 120dB
 and $CMRR_B = +0.5\mu V/V$ or 126dB,
 then $\Delta CMRR = 0.5\mu V/V$ or 126dB
 if $CMRR_B = -0.5\mu V/V$, which is still 126dB,
 then $\Delta CMRR = 1.5\mu V/V$ or 116.5dB.

Typical performance of the instrumentation amplifier:

- Input offset voltage = $25\mu V$.
- Input bias current = 30pA.
- Input resistance = $10^{12}\Omega$.
- Input offset current = 30pA.
- Input noise = $0.7\mu V_{P-P}$.
- Power bandwidth ($V_O = \pm 10V$) = 80kHz.

Clearly, the LT1024, by specifying and guaranteeing all of these matching parameters, can significantly improve the performance of matching dependent circuits.

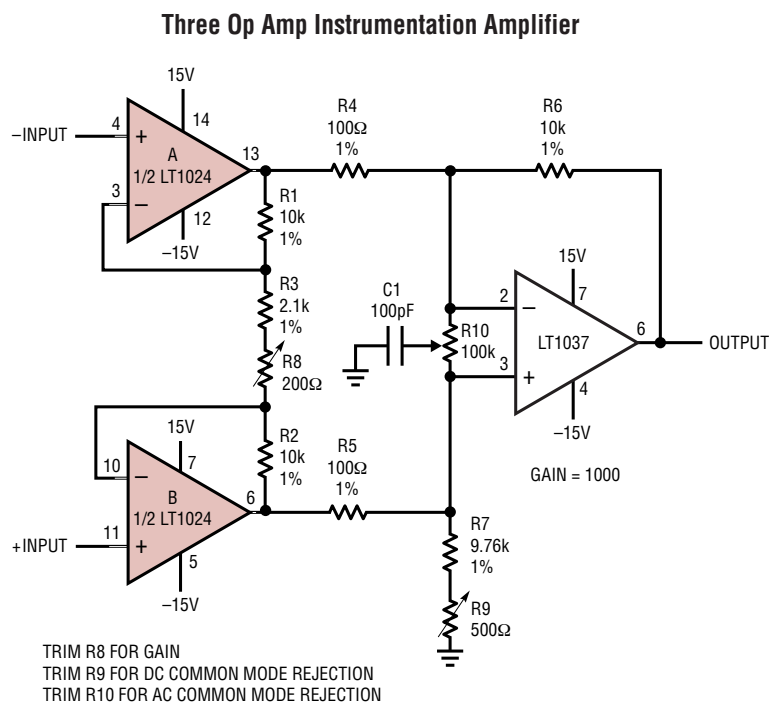

APPLICATIONS INFORMATION

Achieving Picoampere/Microvolt Performance

In order to realize the picoampere/microvolt level accuracy of the LT1024, proper care must be exercised. For example, leakage currents in circuitry external to the op amp can significantly degrade performance. High quality insulation should be used (e.g., Teflon™, Kel-F); cleaning of all insulating surfaces to remove fluxes and other residues will probably be required. Surface coating may be necessary to provide a moisture barrier in high humidity environments.

Board leakage can be minimized by encircling the input circuitry with a guard ring operated at a potential close to that of the inputs: in inverting configurations, the guard ring should be tied to ground; in noninverting connections, to the inverting input. Guarding both sides of the printed circuit board is required. Bulk leakage reduction depends on the guard ring width. Nanoampere level leakage into the offset trim terminals can affect offset voltage and drift with temperature.

Microvolt level error voltages can also be generated in the external circuitry. Thermocouple effects, caused by temperature gradients across dissimilar metals at the contacts to the input terminals, can exceed the inherent drift of the amplifier. Air currents over device leads should be minimized, package leads should be short, and the two input leads should be as close together as possible and maintained at the same temperature.

Teflon is a trademark of Dupont.

Test Circuit for Offset Voltage and its Drift with Temperature

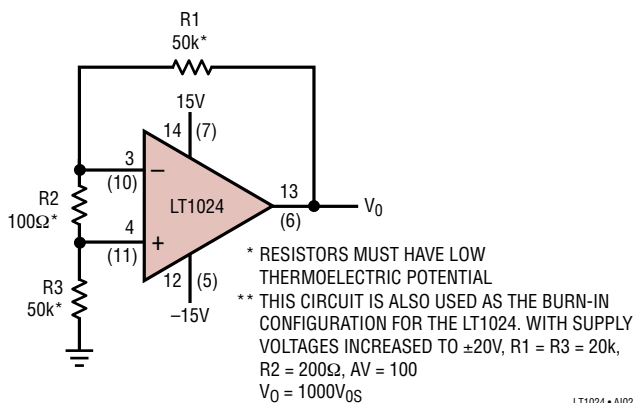

LT1024 • A102

APPLICATIONS INFORMATION

Direct Pressure Transducer to Digital Output Signal Conditioner

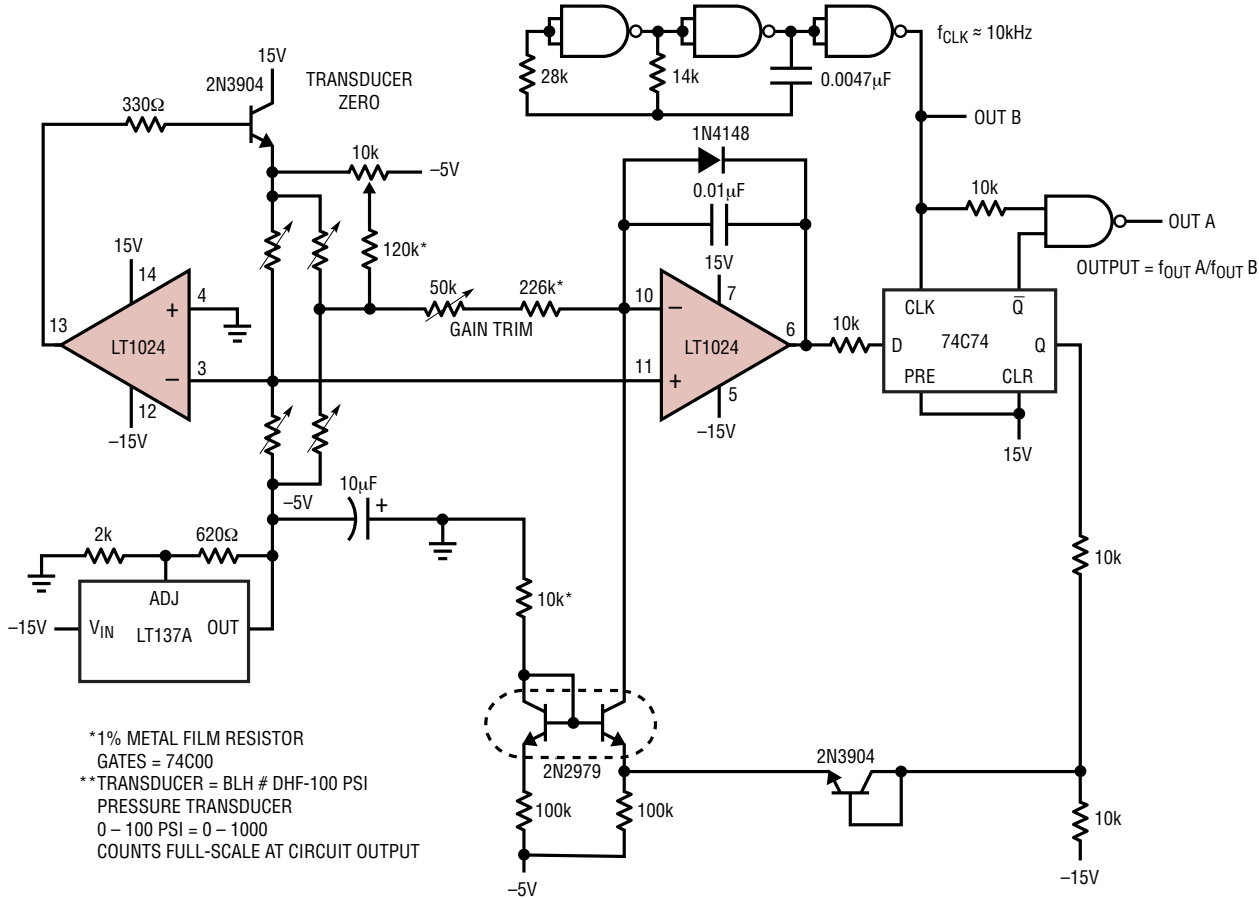

*1% METAL FILM RESISTOR
GATES = 74C00
**TRANSDUCER = BLH # DHF-100 PSI
PRESSURE TRANSDUCER
0 - 100 PSI = 0 - 1000
COUNTS FULL-SCALE AT CIRCUIT OUTPUT

LT1024

SCHEMATIC DIAGRAM

1/2 LT1024

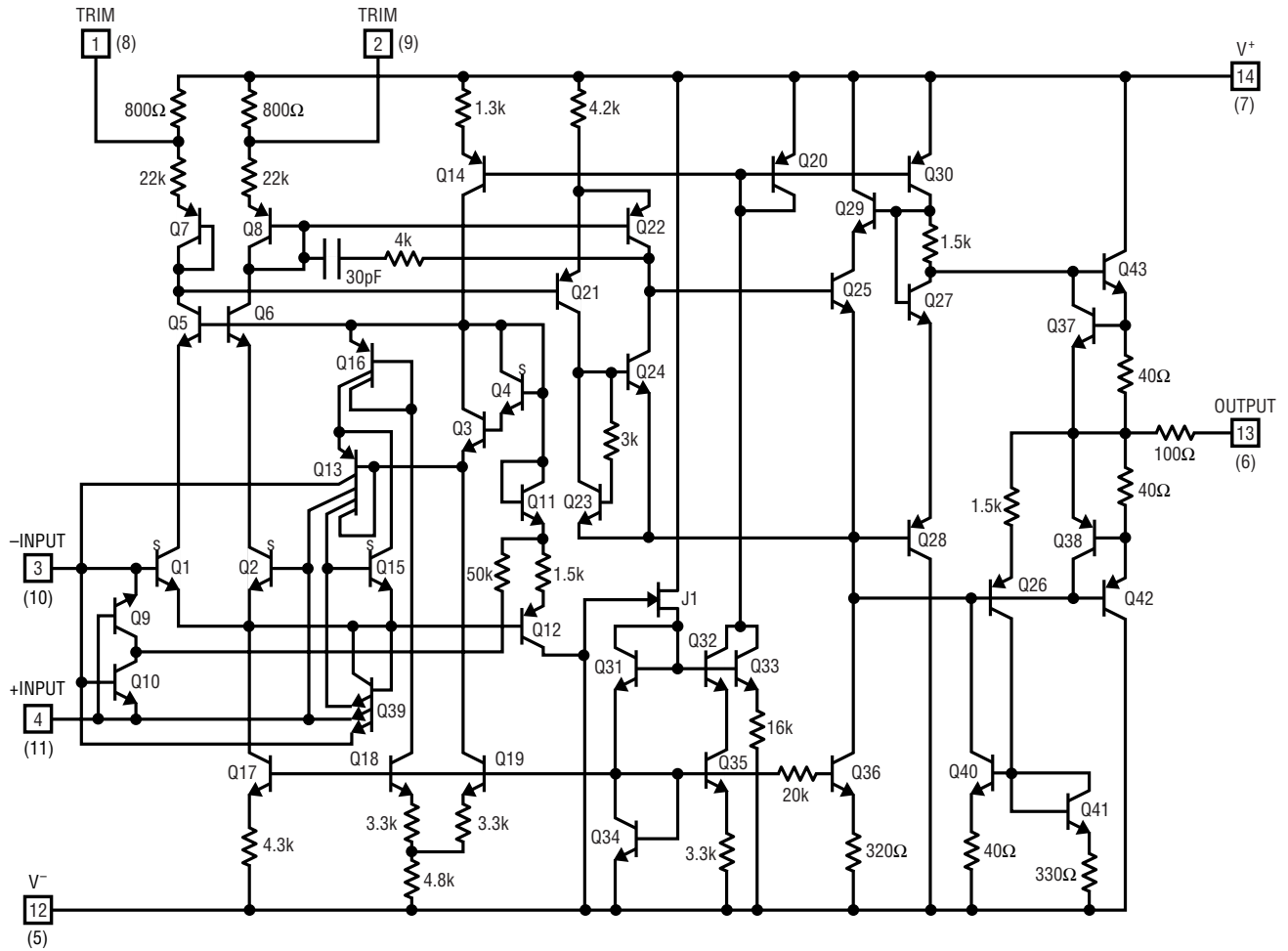

LT1024 * SD01

PACKAGE DESCRIPTION

D Package
14-Lead Side Brazed (Hermetic)
(Reference LTC DWG # 05-08-1210)

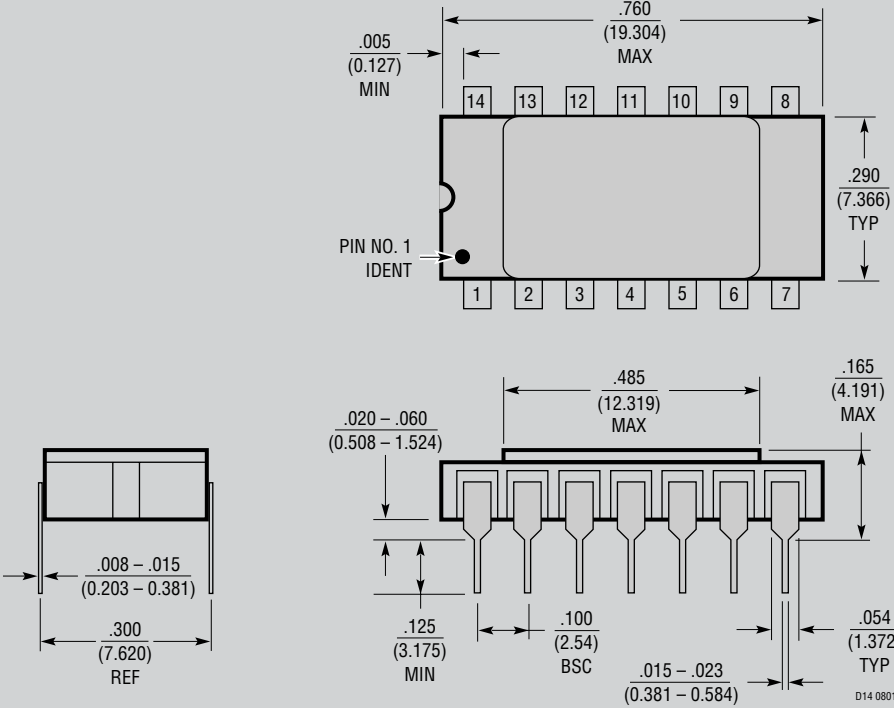

OBSOLETE PACKAGE

LT1024

PACKAGE DESCRIPTION

N Package
14-Lead PDIP (Narrow .300 Inch)
 (Reference LTC DWG # 05-08-1510)

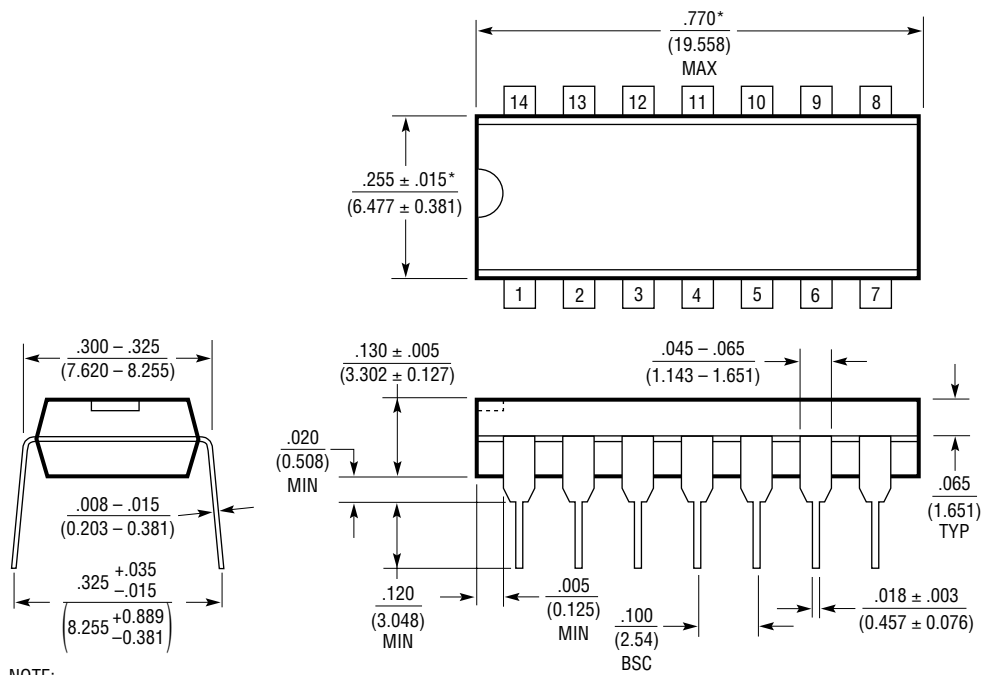

N14 1002

RELATED PARTS

PART NUMBER	DESCRIPTION	COMMENTS
LT1884	Picoamp Input, Precision Op Amp	Rail-to-Rail Output