



General Purpose EMI Reduction IC

Features

- Provides up to 15dB of EMI suppression
- FCC approved method of EMI attenuation
- Generates a 1X, 2X, and 4X low EMI spread spectrum clock of the input frequency
- Input frequency range from 3 to 78MHz
- External loop filter for spread % adjustment
- Spreading ranges from $\pm 0.25\%$ to $\pm 5.0\%$
- Ultra low cycle-to-cycle jitter
- Zero-cycle slip
- 3.3V operating voltage range
- 10 mA output drives
- TTL or CMOS compatible outputs
- Ultra-low power CMOS design
- P278XA is available in 8 pin SOIC and TSSOP Packages
- Available for industrial and automotive temperature ranges.

other digital video and imaging applications. The P278xA reduces electromagnetic interference (EMI) at the clock source, which provides system wide reduction of EMI of all clock dependent signals. The P278xA allows significant system cost savings by reducing the number of circuit board layers and shielding that are traditionally required to pass EMI regulations.

The P278xA uses the most efficient and optimized modulation profile approved by the FCC. The P278xA modulates the output of a single PLL in order to "spread" the bandwidth of a synthesized clock and, more importantly, decreases the peak amplitudes of its harmonics. This results in significantly lower system EMI compared to the typical narrow band signal produced by oscillators and most frequency generators. Lowering EMI by increasing a signal's bandwidth is called spread spectrum clock generation.

Product Description

The P278xA is a versatile spread spectrum frequency modulator designed specifically for digital camera and

Applications

The P278xA is targeted towards MFP, xDSL, fax modem, set-top box, USB controller, DSC, and embedded systems.

Block Diagram

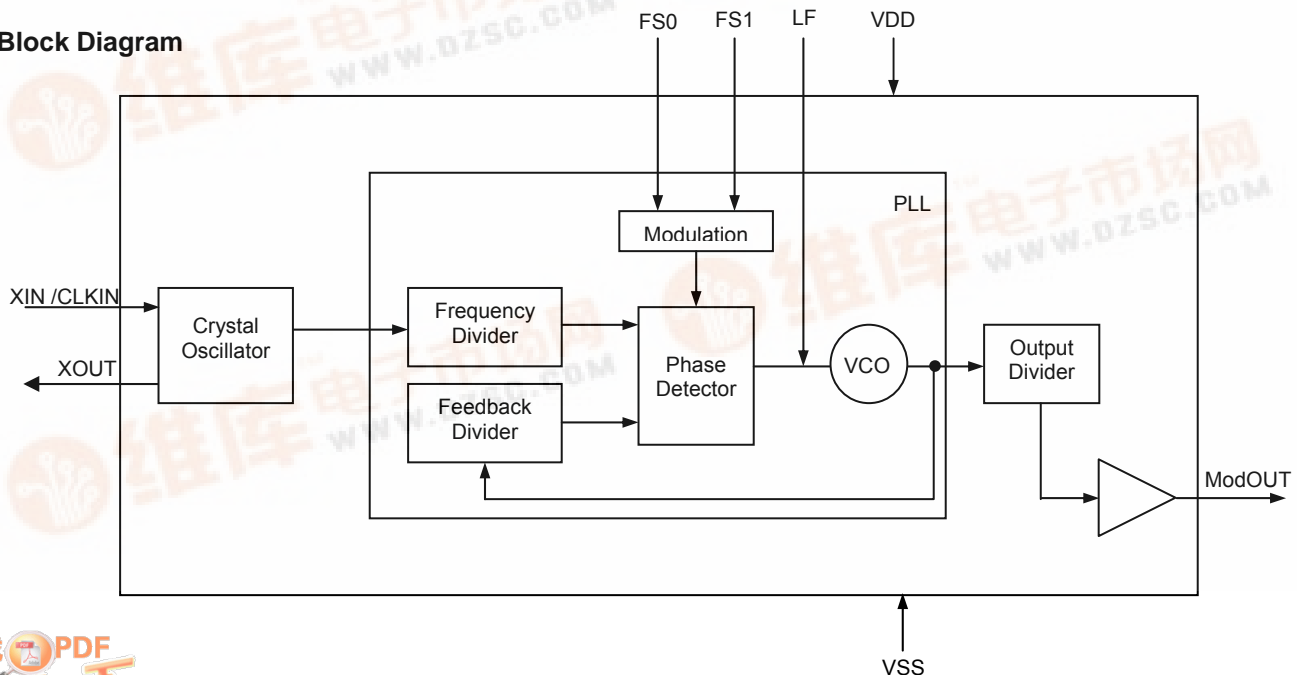



rev 1.5

Pin Configuration

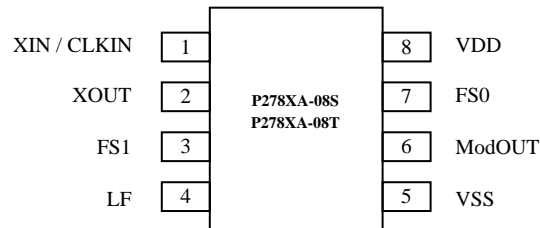

Standard pin Configuration offered in both
8 pin SOIC and TSSOP Packages

Pin Description (P278XA)

Pin#	Pin Name	Type	Description
1	XIN/CLKIN	I	Connect to crystal or clock input. This pin has dual functions. It can be connected either to an external crystal or an external reference clock.
2	XOUT	O	Crystal connection. If using an external reference, this pin must be left unconnected.
3	FS1	I	Digital logic input used to select input frequency range (see the Input Frequency Selection Table). This pin has an internal pull-up resistor.
4	LF	I	External Loop Filter for the PLL. By changing the value of the CRC circuit, the percentage spread can be adjusted accordingly. See the Loop Filter Selection Table for detail value.
5	VSS	I	Ground Connection. Connect to system ground.
6	ModOUT	O	Spread Spectrum Clock Output.
7	FS0	I	Digital logic input used to select input frequency range (see the Input Frequency Selection Table). This pin has an internal pull-up resistor.
8	VDD	P	Connect to +3.3 V

Input Frequency Selection Table

FS1	FS0	Input (MHz)	Output Frequency Scaling (MHz)			Modulation Rate (KHz)
			P2781A	P2782A	P2784A	
0	0	3 to 9	3 to 9	6 to 18	12 to 36	Fin / 128
0	1	10 to 19	10 to 19	20 to 38	40 to 76	Fin / 256
1	0	20 to 38	20 to 38	40 to 76	80 to 152	Fin / 512
1	1	39 to 78	39 to 78	78 to 156	156 to 312	Fin / 1024



rev 1.5

Loop Filter Selection Table VDD 3.3V

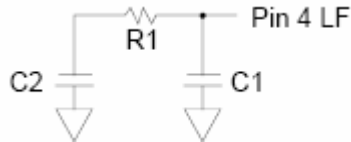

Contact Alliance for loop values that are not listed in the table and for component selection values for industrial and automotive temperatures.

Input MHz	FS1	FS0	BW = ±0.50% ¹			BW = ±0.75% ¹			BW = ±1.00% ¹			BW = ±1.25% ¹		
			C1 (pF)	C2 (pF)	R1 (ohm)	C1 (pF)	C2 (pF)	R1 (ohm)	C1 (pF)	C2 (pF)	R1 (ohm)	C1 (pF)	C2 (pF)	R1 (ohm)
3	0	0	270	330,000	220	270	330,000	300	270	100,000	390	560	100,000	510
4	0	0	270	100,000	270	270	100,000	390	270	100,000	560	560	100,000	680
5	0	0	270	100,000	390	270	100,000	560	270	100,000	750	560	100,000	910
6	0	0	270	100,000	510	270	100,000	750	270	10,000	1,000	680	6,800	1,200
7	0	0	270	100,000	620	270	100,000	1,000	270	5,600	1,200	330	3,300	1,200
8	0	0	270	100,000	820	270	100,000	1,200	270	12,000	2,200	680	6,800	2,200
9	0	0	270	100,000	1,000	270	100,000	1,500	270	5,600	2,200	270	2,700	2,200
10	0	1	270	100,000	330	270	100,000	510	270	100,000	750	560	100,000	910
11	0	1	270	100,000	390	270	100,000	560	270	100,000	866(1%)	560	100,000	1,100
12	0	1	270	100,000	510	270	100,000	750	270	10,000	1,000	680	6,800	1,200
13	0	1	270	100,000	560	270	100,000	820	270	12,000	1,200	470	4,700	1,200
14	0	1	270	100,000	620	270	100,000	1,000	270	5,600	1,200	330	3,300	1,200
15	0	1	270	100,000	750	270	100,000	1,100	270	3,900	1,200	330	3,300	1,500
16	0	1	270	100,000	820	270	100,000	1,200	270	12,000	2,200	680	6,800	2,200
17	0	1	270	100,000	910	270	100,000	1,300	270	10,000	2,200	390	3,900	2,200
18	0	1	270	100,000	1,000	270	100,000	1,500	270	5,600	2,200	270	2,700	2,200
19	0	1	270	100,000	1,200	270	100,000	1,600	270	3,300	2,200	270	2,700	2,700
20	0	0	270	100,000	330	270	100,000	560	270	100,000	750	560	100,000	910
21-22	1	0	270	100,000	390	270	100,000	620	270	100,000	866 (1%)	560	100,000	1,100
23-24	1	0	270	100,000	510	270	100,000	750	270	10,000	1,000	680	6,800	1,200
25-26	1	0	270	100,000	560	270	100,000	820	270	12,000	1,200	470	4,700	1,200
27-28	1	0	270	100,000	620	270	100,000	1,000	270	6,800	1,200	330	3,300	1,200
29-30	1	0	270	100,000	750	270	100,000	1,100	270	3,900	1,200	330	3,300	1,500
31-32	1	0	270	100,000	820	270	100,000	1,200	270	12,000	2,200	680	6,800	2,200
33-34	1	0	270	100,000	910	270	100,000	1,300	270	10,000	2,200	390	3,900	2,200
35-36	1	0	270	100,000	1,000	270	100,000	1,500	270	5,600	2,200	270	2,700	2,200
37-38	1	0	270	100,000	1,200	270	100,000	1,600	270	3,300	2,200	270	2,700	2,700
39-42	1	1	270	100,000	330	270	100,000	560	270	100,000	750	560	100,000	910
43-46	1	1	270	100,000	390	270	100,000	620	270	100,000	866 (1%)	560	100,000	1,100
47-50	1	1	270	100,000	510	270	100,000	750	270	10,000	1,000	680	6,800	1,200
51-54	1	1	270	100,000	560	270	100,000	820	270	12,000	1,200	470	4,700	1,200
55-58	1	1	270	100,000	620	270	100,000	1,000	270	6,800	1,200	330	3,300	1,200
59-62	1	1	270	100,000	750	270	100,000	1,100	270	3,900	1,200	330	3,300	1,500
63-66	1	1	270	100,000	820	270	100,000	1,200	270	12,000	2,200	680	6,800	2,200
67-70	1	1	270	100,000	910	270	100,000	1,300	270	8,200	2,200	390	3,900	2,200
71-74	1	1	270	100,000	1,000	270	100,000	1,600	270	5,600	2,200	270	2,700	2,200
75-78	1	1	270	100,000	1,200	270	100,000	1,800	270	3,300	2,200	270	2,700	2,700

¹ The BW value is representative of typical conditions



rev 1.5

Spread Spectrum Selection

The P278xA performs Zero Cycle Slip when set at low percentage spreading. This allows no occurrence of system timing error. The optimal setting should minimize system EMI to the fullest without affecting system performance. The spreading is described as a percentage deviation of the center frequency.

(Note: the center frequency is the frequency of the external reference input on CLKIN, Pin 1.)

The P2781A is designed for PC peripheral, networking, notebook PC, and LCD monitor applications. It is optimized for operation between 3 to 78MHz range. In the following application schematic example, the P2781A spread percentage selection is determined by the external LF value specified in the Loop Filter Selection Table. The Input Frequency Selection Table specifies the input frequency range. The external LF allows the user to fine tune the spread percentage to optimize the EMI reduction benefits of the spread spectrum.

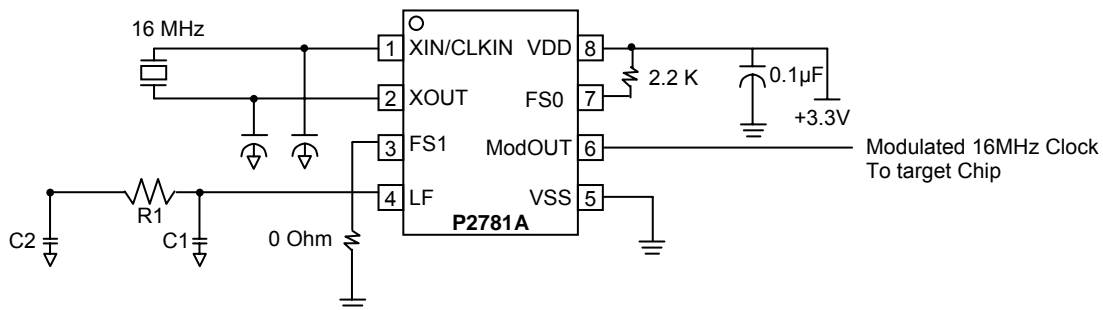

Note: Both logic input pins FS1 and FS0 have to be connected to either VDD or VSS. Do not leave them floating.



rev 1.5

Absolute Maximum Ratings

Symbol	Parameter	Rating	Unit
VDD	Supply voltage, DC	(VSS – 0.5) to 7	V
V _I	Input voltage, DC	(VSS-0.5) to (VDD+0.5)	V
V _O	Output voltage, DC	(VSS-0.5) to (VDD + 0.5)	V
I _{IK}	Input clamp current (V _I <0 or V _I >VDD)	-50 to +50	mA
I _{OK}	Output clamp current (V _I <0 or V _I >VDD)	-50 to +50	mA
T _S	Storage temperature	-65 to +125	°C
T _A	Ambient temperature range, under bias	-55 to 125	°C
T _J	Junction temperature	150	°C
	Lead temperature (soldering 10 sec)	260	°C
	Input static discharge voltage protection (As per JEDEC STD22- A114-B)	2	kV

Note: These are stress ratings only and functional operation is not implied. Exposure to absolute maximum ratings for extended periods may affect device reliability.

DC Electrical Characteristics

(Test condition: All parameters are measured at room temperature (+25°C) unless otherwise stated)

Symbol	Parameter	Min	Typ	Max	Unit
V _{IL}	Input low voltage	VSS – 0.3	-	0.8	V
V _{IH}	Input high voltage	2.0	-	VDD +0.3	V
I _{IL}	Input low current (internal input pull-up resistor on FS0 and FS1)	-	60	-	μA
I _{IH}	Input high current (internal input pull-up resistor on FS0 and FS1)	-	60	-	μA
I _{XOL}	XOUT output low current	-	10	-	mA
I _{XOH}	XOUT output high current	-	10	-	mA
V _{OL}	Output low voltage (VDD = 3.3V, I _{OL} = 20mA)	-	-	0.4	V
V _{OH}	Output high voltage (VDD = 3.3V, I _{OH} = 20mA)	2.5	-	-	V
I _{DD}	Static supply current	-	3	-	mA
I _{CC}	Typical dynamic supply current (25pF scope probe loading)	5.2 at 3MHz	-	21.2 at 82MHz	mA
VDD	Operating voltage	3.0	3.3	3.6	V



rev 1.5

AC Electrical Characteristics

Symbol	Parameter		Min	Typ	Max	Unit
f_{IN}	Input frequency: P278XA		3	-	78	MHz
f_{OUT}	Output frequency:	P2781A P2782A P2784A	3 6 12	-	78 156 312	MHz
t_{LH} P278XA	Output rise time (measured at 0.8 V to 2.0 V, 25pF scope probe loading)		-	1	-	nS
t_{HL} P278XA	Output fall time (measured at 2.0 V to 0.8 V, 25 pF scope probe loading)		-	1	-	nS
t_{JC} P2781A	Jitter (cycle to cycle, $\pm 6\sigma$, 1000 sweeps, $\pm 0.5\%$ spread, I/O frequency = 16MHz)		-	± 250	-	pS
t_D P2781A	Output duty cycle deviation (error from 50% duty cycle, 25pF scope probe loading)		± 1 at 3MHz	-	± 2 at 82MHz	%
ΔF P278XA	Frequency deviation tolerance from BW% stated in the Loop Filter Selection Table		-20	0	+20	%



rev 1.5

Package Information

Mechanical Package Outline 8-Pin SOIC Package

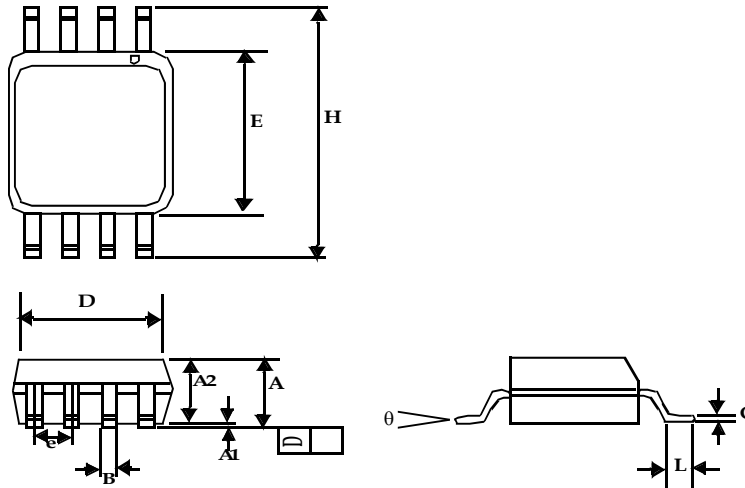

Symbol	Dimensions			
	Inches		Millimeters	
	Min	Max	Min	Max
A1	0.004	0.010	0.10	0.25
A	0.053	0.069	1.35	1.75
A2	0.049	0.059	1.25	1.50
B	0.012	0.020	0.31	0.51
C	0.007	0.010	0.18	0.25
D	0.193 BSC		4.90 BSC	
E	0.154 BSC		3.91 BSC	
e	0.050 BSC		1.27 BSC	
H	0.236 BSC		6.00 BSC	
L	0.016	0.050	0.41	1.27
θ	0°	8°	0°	8°

Note: Controlling dimensions are millimeters
 SOIC - 0.074 grams unit weight



Mechanical Package Outline 8-Pin TSSOP Package

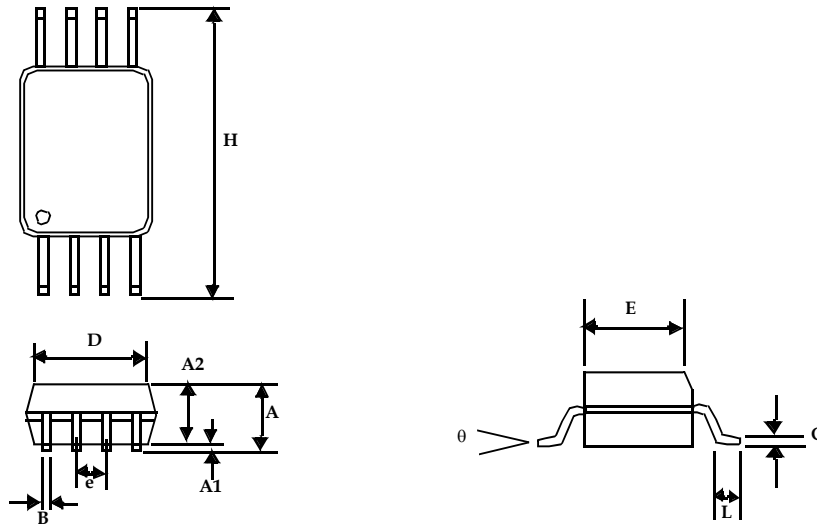

Symbol	Dimensions			
	Inches		Millimeters	
	Min	Max	Min	Max
A		0.043		1.10
A1	0.002	0.006	0.05	0.15
A2	0.033	0.037	0.85	0.95
B	0.008	0.012	0.19	0.30
c	0.004	0.008	0.09	0.20
D	0.114	0.122	2.90	3.10
E	0.169	0.177	4.30	4.50
e	0.026 BSC		0.65 BSC	
H	0.252 BSC		6.40 BSC	
L	0.020	0.028	0.50	0.70
θ	0°	8°	0°	8°

Note: Controlling dimensions are millimeters
TSSOP - 0.0325 grams unit weight



rev 1.5

Ordering Codes

Ordering #	Marking	Package Type	QTY / Reel	Temperature
P278XA-08ST	P278XA	8 PIN SOIC, TUBE		See flow
P278XA-08SR	P278XA	8 PIN SOIC, TAPE & REEL	2,500	See flow
P278XA-08TT	P278XA	8 PIN TSSOP, TUBE		See flow
P278XA-08TR	P278XA	8 PIN TSSOP, TAPE & REEL	2,500	See flow
P278XAF-08ST	P278XAF	8 PIN SOIC, TUBE, Pb Free		See flow
P278XAF-08SR	P278XAF	8 PIN SOIC, TAPE AND REEL, Pb Free	2,500	See flow
P278XAF-08TT	P278XAF	8 PIN TSSOP, TUBE, Pb Free		See flow
P278XAF-08TR	P278XAF	8 PIN TSSOP, TAPE AND REEL, Pb Free	2,500	See flow
P278XAG-08ST	P278XAG	8 PIN SOIC, TUBE, Green		See flow
P278XAG-08SR	P278XAG	8 PIN SOIC, TAPE AND REEL, Green	2,500	See flow
P278XAG-08TT	P278XAG	8 PIN TSSOP, TUBE, Green		See flow
P278XAG-08TR	P278XAG	8 PIN TSSOP, TAPE AND REEL, Green	2,500	See flow
I278XA-08ST	I278XA	8 PIN SOIC, TUBE		See flow
I278XA-08SR	I278XA	8 PIN SOIC, TAPE & REEL	2,500	See flow
I278XA-08TT	I278XA	8 PIN TSSOP, TUBE		See flow
I278XA-08TR	I278XA	8 PIN TSSOP, TAPE & REEL	2,500	See flow
I278XAF-08ST	I278XAF	8 PIN SOIC, TUBE, Pb Free		See flow
I278XAF-08SR	I278XAF	8 PIN SOIC, TAPE AND REEL, Pb Free	2,500	See flow
I278XAF-08TT	I278XAF	8 PIN TSSOP, TUBE, Pb Free		See flow
I278XAF-08TR	I278XAF	8 PIN TSSOP, TAPE AND REEL, Pb Free	2,500	See flow
I278XAG-08ST	I278XAG	8 PIN SOIC, TUBE, Green		See flow
I278XAG-08SR	I278XAG	8 PIN SOIC, TAPE AND REEL, Green	2,500	See flow
I278XAG-08TT	I278XAG	8 PIN TSSOP, TUBE, Green		See flow
I278XAG-08TR	I278XAG	8 PIN TSSOP, TAPE AND REEL, Green	2,500	See flow
X278XA-08ST	X278XA	8 PIN SOIC, TUBE		See flow
X278XA-08SR	X278XA	8 PIN SOIC, TAPE & REEL	2,500	See flow
X278XA-08TT	X278XA	8 PIN TSSOP, TUBE		See flow
X278XA-08TR	X278XA	8 PIN TSSOP, TAPE & REEL	2,500	See flow
X278XAF-08ST	X278XAF	8 PIN SOIC, TUBE, Pb Free		See flow
X278XAF-08SR	X278XAF	8 PIN SOIC, TAPE AND REEL, Pb Free	2,500	See flow
X278XAF-08TT	X278XAF	8 PIN TSSOP, TUBE, Pb Free		See flow
X278XAF-08TR	X278XAF	8 PIN TSSOP, TAPE AND REEL, Pb Free	2,500	See flow
X278XAG-08ST	X278XAG	8 PIN SOIC, TUBE, Green		See flow
X278XAG-08SR	X278XAG	8 PIN SOIC, TAPE AND REEL, Green	2,500	See flow
X278XAG-08TT	X278XAG	8 PIN TSSOP, TUBE, Green		See flow
X278XAG-08TR	X278XAG	8 PIN TSSOP, TAPE AND REEL, Green	2,500	See flow



rev 1.5

Device Ordering Information

P 2 7 8 X A F - 0 8 X X

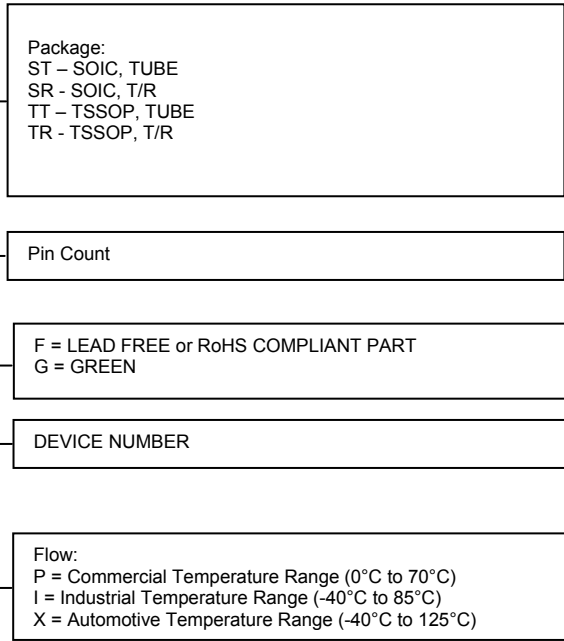



Alliance Semiconductor Corporation
2575, Augustine Drive,
Santa Clara, CA 95054
Tel# 408-855-4900
Fax: 408-855-4999
www.alsc.com

Copyright © Alliance Semiconductor
All Rights Reserved
Part Number: P2781/82/84
Document Version: 1.5

Note: This product utilizes US Patent # 6,646,463 Impedance Emulator Patent issued to Alliance Semiconductor, dated 11-11-2003

© Copyright 2003 Alliance Semiconductor Corporation. All rights reserved. Our three-point logo, our name and Intelliwatt are trademarks or registered trademarks of Alliance. All other brand and product names may be the trademarks of their respective companies. Alliance reserves the right to make changes to this document and its products at any time without notice. Alliance assumes no responsibility for any errors that may appear in this document. The data contained herein represents Alliance's best data and/or estimates at the time of issuance. Alliance reserves the right to change or correct this data at any time, without notice. If the product described herein is under development, significant changes to these specifications are possible. The information in this product data sheet is intended to be general descriptive information for potential customers and users, and is not intended to operate as, or provide, any guarantee or warranty to any user or customer. Alliance does not assume any responsibility or liability arising out of the application or use of any product described herein, and disclaims any express or implied warranties related to the sale and/or use of Alliance products including liability or warranties related to fitness for a particular purpose, merchantability, or infringement of any intellectual property rights, except as express agreed to in Alliance's Terms and Conditions of Sale (which are available from Alliance). All sales of Alliance products are made exclusively according to Alliance's Terms and Conditions of Sale. The purchase of products from Alliance does not convey a license under any patent rights, copyrights; mask works rights, trademarks, or any other intellectual property rights of Alliance or third parties. Alliance does not authorize its products for use as critical components in life-supporting systems where a malfunction or failure may reasonably be expected to result in significant injury to the user, and the inclusion of Alliance products in such life-supporting systems implies that the manufacturer assumes all risk of such use and agrees to indemnify Alliance against all claims arising from such use.



中发网 WWW.ZFA.CN

全球最大的PDF中文下载站



中发网
www.zfa.cn

PDF 资料下载尽在中发网