

MAXIM

四通道铜缆信号调理器

MAX3983

概述

MAX3983是工作于2.5Gbps至3.2Gbps的四通道铜缆信号调理器。它能够为4x铜质InfiniBand和10Gbase-CX4以太网链路提供补偿,允许跨距达20米的24AWG和15米的28AWG电缆连接。电缆驱动器单元提供四种可选的预加重级别。电缆驱动器的输入可补偿最长0.5米的FR4电路板。电缆接收器单元提供固定的输入均衡,同时,为驱动长达0.5米的FR4电路板提供可选的预加重。

MAX3983在所有八个输入通道上还具有信号检测功能和用于诊断测试的内部环回功能。该芯片采用10mm x 10mm、68引脚QFN封装,工作温度范围为0°C至+85°C。

应用

- 4x InfiniBand (4 x 2.5Gbps)
- 10Gbase - CX4 以太网 (4 x 3.125Gbps)
- 10G 光纤信道 XAUI (4 x 3.1875Gbps)
- 4x 铜缆或背板传输 (1Gbps至3.2Gbps)

特性

- ◆ 链路特性
 - 24AWG 跨距20米, 28AWG 跨距15米
 - 每个主机的FR4跨距达0.5m
 - 3.3V电源下总功耗为1.6W
 - 环回功能
- ◆ 电缆驱动器特性
 - 可选的输出预加重
 - FR4输入均衡
 - 每个通道上的信号检测
 - 可禁止输出
- ◆ 电缆接收器特性
 - 可选的FR4输出预加重
 - 电缆输入均衡
 - 每个通道上的信号检测
 - 可禁止输出

订购信息

PART	TEMP RANGE	PIN-PACKAGE	PKG CODE
MAX3983UGK	0°C to +85°C	68 QFN	G6800-4

引脚配置在本资料的最后。

典型应用电路

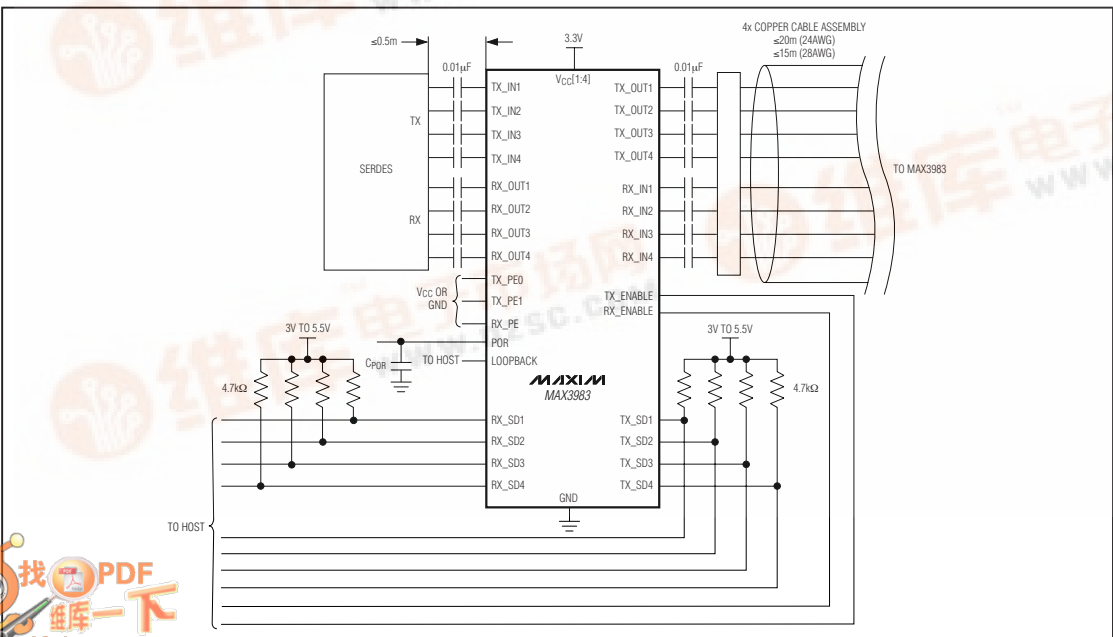

四通道铜缆信号调理器

ABSOLUTE MAXIMUM RATINGS

Supply Voltage, V_{CC}-0.5V to +6.0V
 Continuous CML Output Current at
 TX_OUT[1:4]±, RX_OUT[1:4]±±25mA
 Voltage at TX_IN[1:4]±, RX_IN[1:4]±, RX_SD[1:4],
 TX_SD[1:4], RX_ENABLE, TX_ENABLE, RX_PE,
 TX_PE[0:1], LOOPBACK, POR
 (with series resistor $\geq 4.7k\Omega$).....-0.5V to ($V_{CC} + 0.5V$)

Continuous Power Dissipation ($T_A = +85^\circ\text{C}$)
 68-Pin QFN (derate 41.7mW/ $^\circ\text{C}$ above $+85^\circ\text{C}$)2.7W
 Operating Junction Temperature (T_J)..... -55°C to $+150^\circ\text{C}$
 Storage Ambient Temperature Range (T_S) -55°C to $+150^\circ\text{C}$

Stresses beyond those listed under "Absolute Maximum Ratings" may cause permanent damage to the device. These are stress ratings only, and functional operation of the device at these or any other conditions beyond those indicated in the operational sections of the specifications is not implied. Exposure to absolute maximum rating conditions for extended periods may affect device reliability.

ELECTRICAL CHARACTERISTICS

($V_{CC} = +3.0V$ to $+3.6V$, $T_A = 0^\circ\text{C}$ to $+85^\circ\text{C}$. Typical values are at $V_{CC} = +3.3V$ and $T_A = +25^\circ\text{C}$, unless otherwise noted.)

PARAMETER	SYMBOL	CONDITIONS	MIN	TYP	MAX	UNITS
Supply Current		RX_EN = V_{CC} , TX_EN = 0V		360	430	mA
		RX_EN = 0V, TX_EN = V_{CC}		365	430	
		RX_EN = V_{CC} , TX_EN = V_{CC}		495	580	
OPERATING CONDITIONS						
Supply Voltage	V_{CC}		3.0	3.3	3.6	V
Supply Noise Tolerance		$1\text{MHz} \leq f < 2\text{GHz}$		40		mV _{P-P}
Operating Ambient Temperature	T_A		0	25	85	$^\circ\text{C}$
Bit Rate		NRZ data (Note 1)	2.5		3.2	Gbps
CID		Consecutive identical digits (bits)			10	Bits
STATUS OUTPUTS: RX_SD[1:4], TX_SD[1:4]						
Signal-Detect Open-Collector Current Sink		Signal detect asserted	0		25	μA
		Signal detect unasserted $V_{OL} \leq 0.4V$ with $4.7k\Omega$ pullup resistor	1.0	1.11		mA
		$V_{CC} = 0V$, pullup supply = 5.5V, external pullup resistor $\geq 4.7k\Omega$	0		25	μA
Signal-Detect Response Time		Time from RX_IN[1:4] or TX_IN[1:4] dropping below 85mV _{P-P} or rising above 175mV _{P-P} to 50% point of signal detect		0.35		μs
Signal-Detect Transition Time		Rise time or fall time (10% to 90%)		200		ns
Power-On Reset Delay		$1\mu\text{F}$ capacitor on POR to GND		6		ms
CONTROL INPUTS: RX_ENABLE, TX_ENABLE, RX_PE, TX_PE0, TX_PE1, LOOPBACK						
Voltage, Logic High	V_{IH}		1.5			V
Voltage, Logic Low	V_{IL}				0.5	V
Current, Logic High	I_{IH}	$V_{IH} = V_{CC}$	-150		+150	μA
Current, Logic Low	I_{IL}	$V_{IL} = 0V$	-150		+150	μA

四通道铜缆信号调理器

MAX3983

ELECTRICAL CHARACTERISTICS (continued)

(V_{CC} = +3.0V to +3.6V, T_A = 0°C to +85°C. Typical values are at V_{CC} = +3.3V and T_A = +25°C, unless otherwise noted.)

PARAMETER	SYMBOL	CONDITIONS	MIN	TYP	MAX	UNITS	
TX SECTION (CABLE DRIVER)							
PC Board Input Swing		Measured differentially at the signal source (Note 1)	800		1600	mV _{p-p}	
Input Resistance		TX_IN[1:4]+ to TX_IN[1:4]-, differential	85	100	115	Ω	
Input Return Loss		100MHz to 2GHz (Note 1)	10	17		dB	
Output Swing		TX_ENABLE = high (Notes 1, 2)	1300	1500	1600	mV _{p-p}	
		TX_ENABLE = low			30		
Output Resistance		TX_OUT[1:4]+ or TX_OUT[1:4]- to V _{CC} , single ended	42	50	58	Ω	
Output Return Loss		100MHz to 2GHz (Note 1)	10	13		dB	
Output Transition Time	t _r , t _f	20% to 80% (Notes 1, 3)			80	ps	
Random Jitter		(Notes 1, 3)			1.6	psRMS	
Output Preemphasis		See Figure 1	TX_PE1	TX_PE0		dB	
			0	0	3		
			0	1	6		
			1	0	9		
			1	1	12		
Residual Output Deterministic Jitter at 2.5Gbps (Notes 1, 4, 5)		Source to TX_IN	TX_OUT to Load	TX_PE1	TX_PE0	0.10 0.15	UI _{p-p}
		6-mil FR4 ≤ 20in	1m, 28AWG	0	0		
			5m, 28AWG	0	1		
			10m, 24AWG	1	0		
			15m, 24AWG	1	1		
Residual Output Deterministic Jitter at 3.2Gbps (Notes 1, 4, 5)		Source to TX_IN	TX_OUT to Load	TX_PE1	TX_PE0	0.15 0.20	UI _{p-p}
		6-mil FR4 ≤ 20in	1m, 28AWG	0	0		
			5m, 28AWG	0	1		
			10m, 24AWG	1	0		
			15m, 24AWG	1	1		
Signal-Detect Assert Level		TX_IN for TX_SD = high (Note 6)	800			mV _{p-p}	
Signal-Detect Off		TX_IN for TX_SD = low (Note 6)			200	mV _{p-p}	
RX SECTION (CABLE RECEIVER)							
Cable Input Swing		Measured differentially at the signal source (Note 1)	1000		1600	mV _{p-p}	
Input Vertical Eye Opening		Measured differentially at the input of the MAX3983 (Note 1)	175		1600	mV _{p-p}	
Input Resistance		RX_IN[1:4]+ to RX_IN[1:4]-, differential	85	100	115	Ω	
Input Return Loss		100MHz to 2GHz (Note 1)	10	18		dB	

四通道铜缆信号调理器

MAX3983

ELECTRICAL CHARACTERISTICS (continued)

(V_{CC} = +3.0V to +3.6V, T_A = 0°C to +85°C. Typical values are at V_{CC} = +3.3V and T_A = +25°C, unless otherwise noted.)

PARAMETER	SYMBOL	CONDITIONS			MIN	TYP	MAX	UNITS		
Output Swing		RX_ENABLE = high (Notes 1, 7)			1100		1500	mV _{P-P}		
		RX_ENABLE = low					30			
Output Resistance		RX_OUT[1:4]+ or RX_OUT[1:4]- to V _{CC} , single ended			42	50	58	Ω		
Output Return Loss		100MHz to 2GHz (Note 1)			10	15		dB		
Output Transition Time	t _r , t _f	20% to 80% (Notes 1, 8)				45	80	ps		
Random Jitter		(Notes 1, 8)					1.6	psRMS		
Output Preemphasis		RX_PE = low				3		dB		
		RX_PE = high				6				
Residual Output Deterministic Jitter at 2.5Gbps (Notes 1, 5, 9, 10)		Source to RX_IN	RX_OUT to Load	RX_PE	0.10	0.15	U _I P-P			
		5m, 28AWG IB Cable Assembly without preemphasis	0in, 6-mil FR4	0						
			20in, 6-mil FR4	1						
Residual Output Deterministic Jitter at 3.2Gbps (Notes 1, 5, 9, 10)		Source to RX_IN	RX_OUT to Load	RX_PE	0.15	0.20	U _I P-P			
		5m, 28AWG IB cable assembly without preemphasis	0in, 6-mil FR4	0						
			20in, 6-mil FR4	1						
Signal-Detect Assert Level		RX_IN for RX_SD = high (Note 11)			175			mV _{P-P}		
Signal-Detect Off		RX_IN for RX_SD = low (Note 11)					85	mV _{P-P}		
END-TO-END JITTER (TX AND RX COMBINED PERFORMANCE)										
Residual Output Deterministic Jitter at 2.5Gbps (Notes 1, 12, 13, 14)		Source to TX_IN	TX_OUT to RX_IN	TX_PE1	TX_PE0	RX_OUT to Load	RX_PE	0.15	0.20	U _I P-P
		6-mil FR4 ≤ 20in	1m, 24AWG	0	0	0in	0			
			15m, 24AWG	1	1	20in	1			
			20m, 24AWG	1	1	20in	1			
							0.2	0.25		

四通道铜缆信号调理器

MAX3983

ELECTRICAL CHARACTERISTICS (continued)

(V_{CC} = +3.0V to +3.6V, T_A = 0°C to +85°C. Typical values are at V_{CC} = +3.3V and T_A = +25°C, unless otherwise noted.)

PARAMETER	SYMBOL	CONDITIONS					MIN	TYP	MAX	UNITS
Residual Output Deterministic Jitter at 3.2Gbps (Notes 1, 12, 13, 14)		Source to TX_IN	TX_OUT to RX_IN	TX_PE1	TX_PE0	RX_OUT to Load	RX_PE	0.20	0.25	UI _{P-P}
				0	0					
		6-mil FR4 ≤ 20 in	15m, 24AWG	1	1	20in	1	0.25	0.3	
			20m, 24AWG	1	1	20in	1			

Note 1: Guaranteed by design and characterization.

Note 2: Measured with 2in of FR4 through InfiniBand connector with TX_PE1 = TX_PE0 = 1.

Note 3: Measured at the chip using 0000011111 or equivalent pattern. TX_PE1 = TX_PE0 = 0 for minimum preemphasis.

Note 4: All channels under test are not transmitting during test. Channel tested with XAUI CJPAT, as well as this pattern: 19 zeros, 1, 10 zeros, 1010101010 (D21.5 character), 1100000101 (K28.5+ character), 19 ones, 0, 10 ones, 0101010101 (D10.2 character), 0011111010 (K28.5- character).

Note 5: Cables are unequalized, Amphenol Spectra-Strip 24AWG and 28AWG or equivalent equipped with Fujitsu "MicroGiga" connector or equivalent. All other channels are quiet. Residual deterministic jitter is the difference between the source jitter and the output jitter at the load. The deterministic jitter (DJ) at the output of the transmission line must be from media-induced loss and not from clock-source modulation. Depending upon the system environment, better results can be achieved by selecting different preemphasis levels.

Note 6: Tested with a 1GHz sine wave applied at TX_IN under test with less than 5in of FR4.

Note 7: Measured with 3in of FR4 with RX_PE = 1.

Note 8: Measured at the chip using 0000011111 or equivalent pattern. RX_PE = low (minimum). Signal source is 1V_{P-P} with 5m, 28AWG InfiniBand cable.

Note 9: All other receive channels are quiet. TX_ENABLE = 0. Channel tested with XAUI CJPAT as well as this pattern: 19 zeros, 1, 10 zeros, 1010101010 (D21.5 character), 1100000101 (K28.5+ character), 19 ones, 0, 10 ones, 0101010101 (D10.2 character), 0011111010 (K28.5- character).

Note 10: FR4 board material: 6-mil-wide, 100Ω, edge-coupled stripline (tanδ = 0.022, 4.0 < ε_R < 4.4).

Note 11: Tested with a 1GHz sine wave applied at RX_IN under test with less than 5in of FR4.

Note 12: Channel tested with XAUI CJPAT as well as this pattern: 19 zeros, 1, 10 zeros, 1010101010 (D21.5 character), 1100000101 (K28.5+ character), 19 ones, 0, 10 ones, 0101010101 (D10.2 character), 0011111010 (K28.5- character).

Note 13: Cables are unequalized, Amphenol Spectra-Strip 24AWG or equivalent equipped with Fujitsu "MicroGiga" connector or equivalent. Residual deterministic jitter is the difference between the source jitter at point A and the load jitter at point B in Figure 2. The deterministic jitter (DJ) at the output of the transmission line must be from media-induced loss and not from clock-source modulation. Depending upon the system environment, better results can be achieved by selecting different preemphasis levels.

Note 14: Valid with pattern generator deterministic jitter as high as 0.17UI_{P-P}.

四通道铜缆信号调理器



图1. 以 dB 表示的 TX 预加重



图2. 端-端测试装置。A、B标注点请参考交流参数测试条件。

四通道铜缆信号调理器

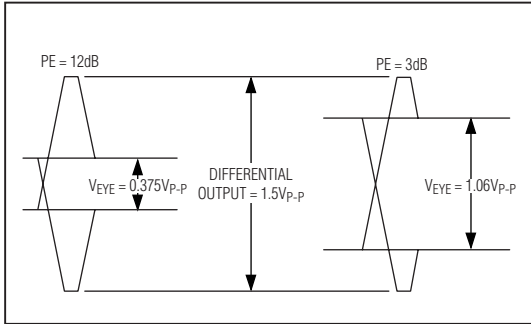
典型工作特性

(VCC = +3.3V, TA = +25°C, unless otherwise noted.)

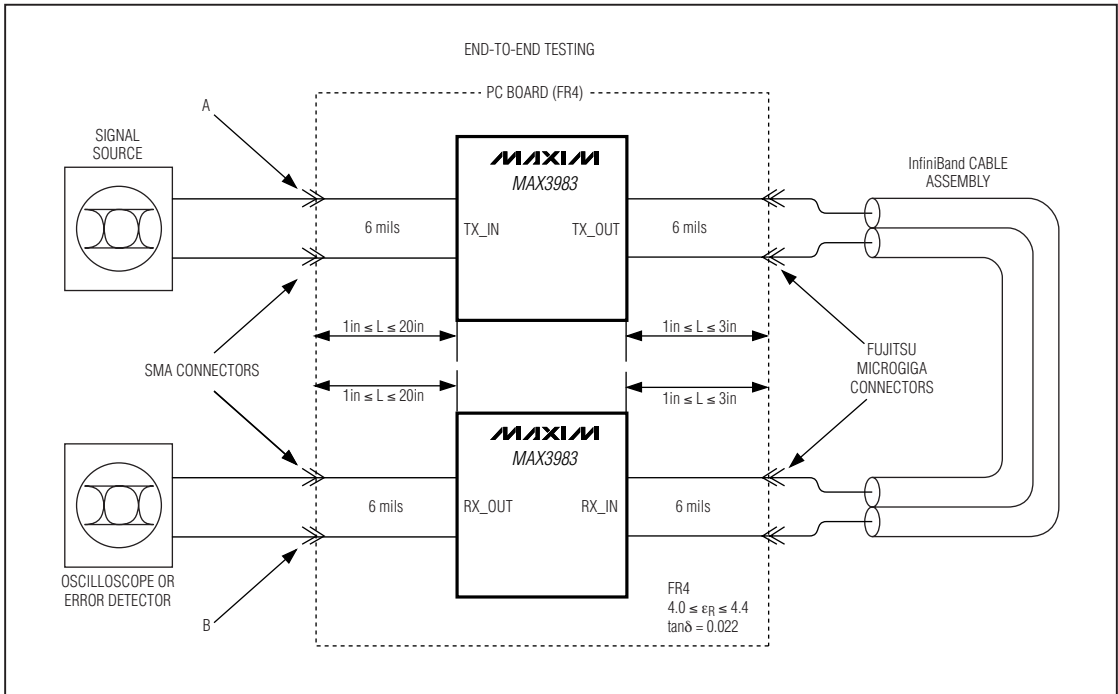
MAX3983

TRANSIENT RESPONSE

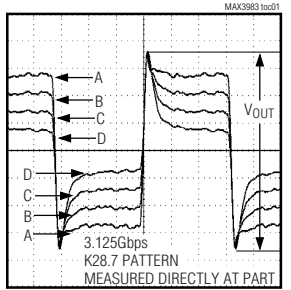

A = 3dB, TX_PE[1,0] = 00 C = 9dB, TX_PE[1,0] = 10
B = 6dB, TX_PE[1,0] = 01 D = 12dB, TX_PE[1,0] = 11

VERTICAL EYE OPENING vs. CABLE LENGTH

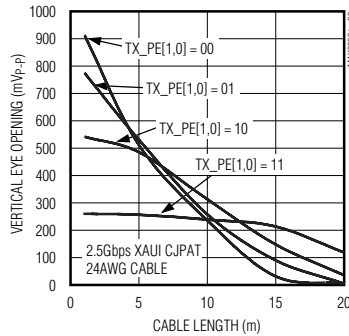

END-TO-END DETERMINISTIC JITTER vs. CABLE LENGTH

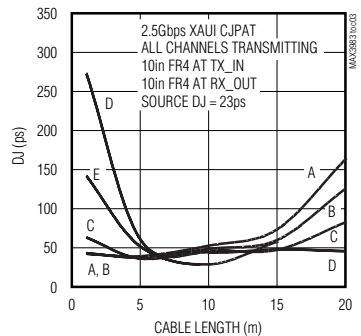

A = 24AWG, TX_PE[1,0] = 00 D = 24AWG, TX_PE[1,0] = 11
B = 24AWG, TX_PE[1,0] = 01 E = 28AWG, TX_PE[1,0] = 11
C = 24AWG, TX_PE[1,0] = 10

10m 24AWG UNEQUALIZED CABLE ASSEMBLY OUTPUT WITHOUT MAX3983

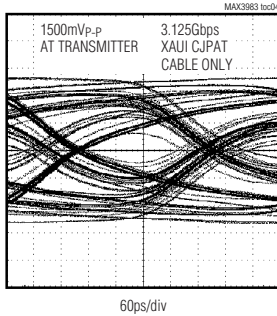

10m 24AWG UNEQUALIZED CABLE ASSEMBLY OUTPUT WITH MAX3983 PREAMPHASIS

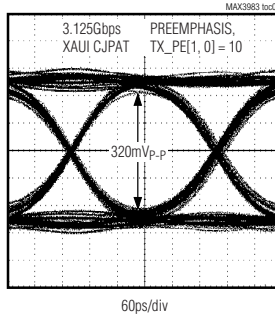

TX_IN INPUT RETURN LOSS vs. FREQUENCY

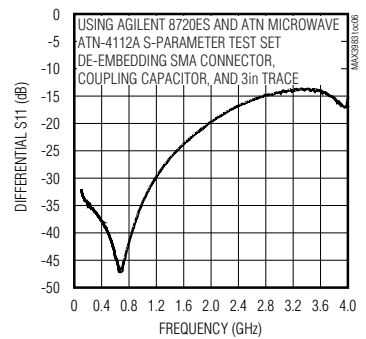

四通道铜缆信号调理器

典型工作特性 (续)

(VCC = +3.3V, TA = +25°C, unless otherwise noted.)

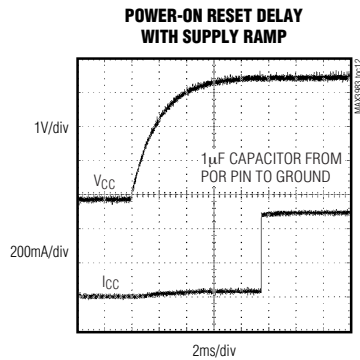
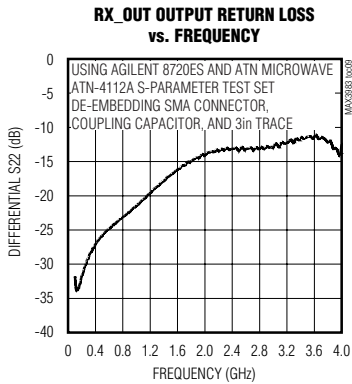
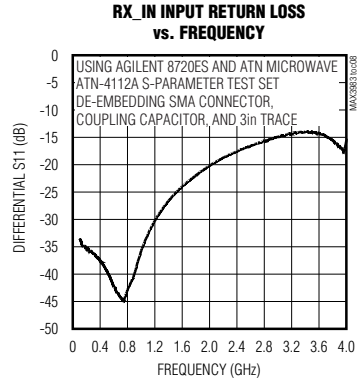
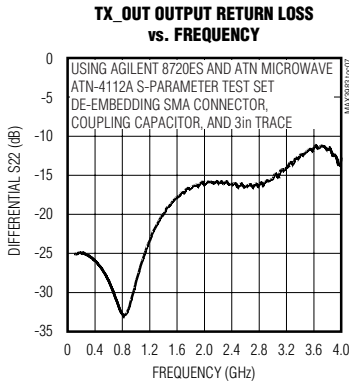

四通道铜缆信号调理器

引脚说明

MAX3983

引脚	名称	功能
1, 2, 16, 17	TX_SD1 to TX_SD4	PC 板接收器信号检测, TTL 输出。该输出是集电极开路 TTL, 因此需要与 V_{CC} 之间外接一个 $4.7k\Omega \sim 10k\Omega$ 的上拉电阻。当输入信号电平无效时这些输出吸收电流。
3, 15	V_{CC1}	TX 输入电源, 为 +3.3V。
4, 7, 10, 13	TX_IN1- to TX_IN4-	PC 板接收器数据输入负端, CML。这些输入在内部用 100Ω 差分端接至对应的 TX_IN+。
5, 8, 11, 14	TX_IN1+ to TX_IN4+	PC 板接收器数据输入正端, CML。这些输入在内部用 100Ω 差分端接至对应的 TX_IN-。
6, 9, 12, 40, 43, 46	GND	电路地。
18	TX_ENABLE	电缆发送器使能输入, 含内部 $40k\Omega$ 上拉的 LVTTTL。该引脚使能所有四路电缆发送器输出 TX_OUT[1:4]。LVTTTL 为低时, 差分输出低于 $30mV_{p-p}$ 。置高或开路时正常工作。
19	N.C.	无连接。不要连接此引脚
20, 23, 26, 29, 32	V_{CC2}	用于 TX 输出的电源连接。接至 +3.3V。
21, 24, 27, 30	TX_OUT1+ to TX_OUT4+	电缆发送器数据输出正端, CML。这些输出通过 50Ω 端接至 V_{CC2} 。
22, 25, 28, 31	TX_OUT1- to TX_OUT4-	电缆发送器数据输出负端, CML。这些输出通过 50Ω 端接至 V_{CC2} 。
33	TX_PE0	电缆发送器预加重控制输入, 含内部 $40k\Omega$ 上拉的 LVTTTL。2 位预加重控制字的最低有效位。置高或开路触发该位。
34	TX_PE1	电缆发送器预加重控制输入, 含内部 $40k\Omega$ 上拉的 LVTTTL。2 位预加重控制字的最高有效位。置高或开路触发该位。
35, 36, 50, 51	RX_SD4 to RX_SD1	电缆接收器信号检测, TTL 输出。该输出为集电极开路 TTL, 因此需要与 V_{CC} 之间外接一个 $4.7k\Omega \sim 10k\Omega$ 的上拉电阻。当输入信号电平无效时这些输出引脚吸收电流。
37, 49	V_{CC3}	RX 输入电源, 接至 +3.3V。
38, 41, 44, 47	RX_IN4- to RX_IN1-	电缆接收器数据输入负端, CML。这些输入在内部用 100Ω 差分端接至对应的 RX_IN+。
39, 42, 45, 48	RX_IN4+ to RX_IN1+	电缆接收器数据输入正端, CML。这些输入在内部用 100Ω 差分端接至对应的 RX_IN-。
52	RX_ENABLE	PC 板发送器使能输入, 含内部 $40k\Omega$ 上拉的 LVTTTL。该引脚使能所有四路 PC 板发送器输出 RX_OUT[1:4]。为低时, 差分输出低于 $30mV_{p-p}$ 。置高或开路时正常工作。
53	POR	上电复位连接引脚。外接一个 $0.1\mu F - 10\mu F$ 的电容到地。参见详细说明。
54, 57, 60, 63, 66	V_{CC4}	RX 输出电源, 接至 +3.3V。

四通道铜缆信号调理器

引脚说明 (续)

引脚	名称	功能
55, 58, 61, 64	RX_OUT4+ to RX_OUT1+	PC板发送器数据输出正端, CML。这些输出通过 50Ω 端接至 V _{CC4} 。
56, 59, 62, 65	RX_OUT4- to RX_OUT1-	PC板发送器数据输出负端, CML。这些输出通过 50Ω 端接至 V _{CC4} 。
67	RX_PE	PC板发送器预加重控制输入, 含内部 40kΩ 上拉的 LVTTTL。置高或开路触发该位。
68	LOOPBACK	环回使能输入, 含内部 40kΩ 上拉的 LVTTTL。置低为正常工作。置高或开路时 TX_IN 内部连接至 RX_OUT。环回使能后 TX_OUT 继续为发送状态。
EP	Exposed Pad	裸露底盘。信号和电源地。为获得最佳的高频和导热性能, 必须将底盘焊接在电路板上。



图3. 功能图

四通道铜缆信号调理器

详细说明

信号检测输出

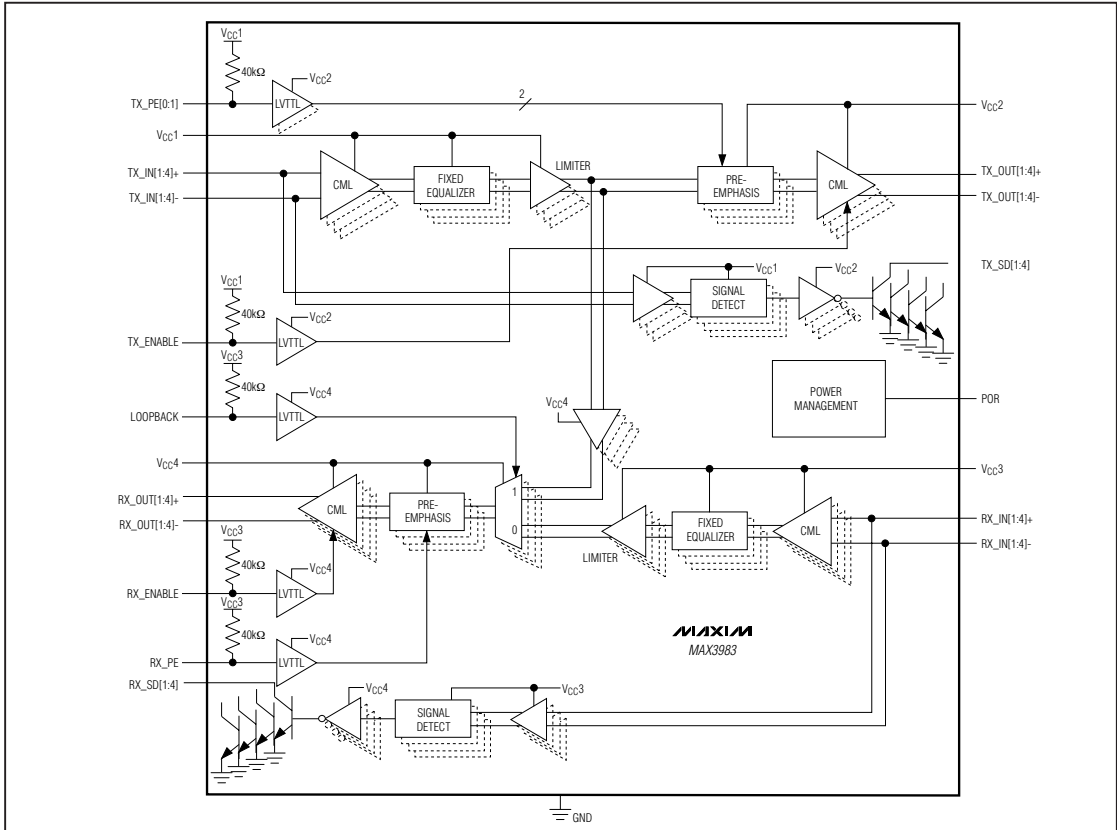
MAX3983 包含一组 PC 板接收器和电缆驱动器单元 (TX)，以及一组电缆接收器和 PC 板驱动器单元 (RX)。每个接收器都具有均衡和信号检测功能，每个发送器都包含预加重。MAX3983 具有独立的 TX 输出和 RX 输出使能控制，还提供用于诊断测试的环回功能。

PC 板接收器和电缆驱动器
(TX_IN 和 TX_OUT)

数据由主机馈入 MAX3983，经过 CML 输入级进入固定均衡级。PC 板接收器内的固定均衡器可以纠正长达 20 英寸的 FR4 PC 板损耗。电缆驱动器采用四态预加重电路补偿长达 20 米的 24AWG、100Ω 平衡电缆损耗。表 1 给出了几种不同预加重表达方式间的简单转换。MAX3983 的残余抖动与最高至 0.17UI_{P-P} 的源抖动无关。

电缆接收器和 PC 板驱动器
(RX_IN 和 RX_OUT)

每个 RX 输入端的固定均衡器提供将近 6dB 的均衡，可补偿最长为 5 米的 28AWG、100Ω 平衡电缆。PC 板驱动器包含有两态预加重，可补偿最长为 20 英寸的 FR4 板材。

全部八个数据输入端都集成了信号检测 (SD) 功能。SD 输出应通过外部上拉电阻连接至 3.0V 至 5.5V 的电源电压。信号检测器的输出在完全上电之前是无效的。信号检测器的响应时间典型值为 0.35μs。

在 RX 单元，当 RX_IN 信号幅度大于 175mV_{P-P} 时 SD 输出触发为高。当 RX_IN 信号幅度降低到 85mV_{P-P} 以下时 RX_SD 恢复为低。

在 TX 单元，当 TX_IN 信号幅度大于 800mV_{P-P} 时 SD 输出触发为高。当 TX_IN 信号幅度降低到 200mV_{P-P} 以下时 TX_SD 恢复为低。

TX 和 RX 使能

TX_ENABLE 和 RX_ENABLE 引脚分别使能 TX 和 RX。典型的使能时间是 15ns，典型禁止时间是 25ns。可将使能输入与信号检测输出相连实现对输入信号的自动检测 (参见自动检测部分)。

上电复位

为限制浪涌电流，MAX3983 内部集成了上电复位电路。在 POR 引脚和地之间连接一只 $0.1\mu\text{F} \leq C_{\text{POR}} \leq 10\mu\text{F}$ 的电容。当 $C_{\text{POR}} = 1\mu\text{F}$ 时，上电延迟时间为 6ms (典型值)。

表 1、预加重转换表

RATIO	α	10Gbase-CX4	IN dB
$\frac{V_{\text{HIGH_PP}}}{V_{\text{LOW_PP}}}$	$\frac{V_{\text{HIGH_PP}} - V_{\text{LOW_PP}}}{V_{\text{HIGH_PP}} + V_{\text{LOW_PP}}}$	$1 - \frac{V_{\text{LOW_PP}}}{V_{\text{HIGH_PP}}}$	$20 \left[\log \left(\frac{V_{\text{HIGH_PP}}}{V_{\text{LOW_PP}}} \right) \right]$
1.41	0.17	0.29	3
2.00	0.33	0.50	6
2.82	0.48	0.65	9
4.00	0.60	0.75	12

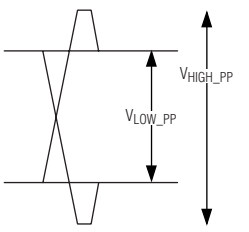

四通道铜缆信号调理器

应用信息

信号检测输出漏电流的考虑

若需要将四路 RX 或 TX 信号检测输出连在一起形成一路信号检测输出时，则需要考虑输出级的漏电流。当被触发时，每路 SD 输出最多可吸收 $25\mu\text{A}$ 电流，因此四路连接在一起时最大电流为 $100\mu\text{A}$ 。在选择上拉至 V_{PULLUP} 的上拉电阻值时，应该保证该漏电流不会使输出电压降低到下一级电路的门限以下。例如，若将信号检测输出脚接在一起连接到一个逻辑高门限为 1.5V 的电路时，上拉电阻的取值应该保证 $V_{\text{PULLUP}} - I_{\text{LEAKAGE}} \times R_{\text{PULLUP}} > 1.5\text{V}$ 。在此情况下，若 $V_{\text{PULLUP}} = 3.0\text{V}$ ，则 R_{PULLUP} 应该小于 $15\text{k}\Omega$ 。

自动检测

MAX3983 能自动检测输入信号并使能相应的输出。RX 侧的自动检测功能是将 RX_SD[1:4] 通过一只电阻上拉后（阻值 $4.7\text{k}\Omega$ 至 $10\text{k}\Omega$ ，上拉至 V_{CC} ）与 RX_ENABLE 相连实现的。对于 TX 侧，可将 TX_SD[1:4] 通过一只电阻上拉后（阻值 $4.7\text{k}\Omega$ 至 $10\text{k}\Omega$ ，上拉至 V_{CC} ）与 TX_ENABLE 相连实现。若在所有通道上检测到信号，则 SD 置高，并使相应的 ENABLE 置高。由于会放大噪声并出现不希望的输出信号，建议不要使 MAX3983 的输入脚处于

未连接（浮空）状态。建议使用自动检测以消除噪声放大或可能的振荡。当使用自动检测时，链路长度取决于接收信号的强度。若未使用自动检测结构，则有可能达到更长的距离。

使用环回和自动检测

若将 MAX3983 设置成自动检测，则 RX_ENABLE 由 RX_SD[1:4] 输出来控制。由于环回要求将 RX_ENABLE 置高，可用一个简单的或门使能 RX 输出，当 RX_SD[1:4] 为高或 LOOPBACK 为高都可使能 RX（图 5）。

InfiniBand 和 10Gbase-CX4 对于转换时间的规定

InfiniBand 规定了 100ps 的最小转换时间（20% 至 80%），CX4 规定了 60ps 的最小转换时间。两者都是在与电缆接口的连接器位置做的规定。MAX3983 的输出转换时间是 45ps （典型值），因此需要仔细考虑延长该时间。3 英寸左右长、4mil 宽的 FR4 引线足以将转换时间延长至 60ps 。对于 100ps 转换时间，可增加长度或在 MAX3983 的输出脚并联一个 1.5pF 电容。若应用中需要使用 InfiniBand 或者 CX4 类型的连接器系统，则电路板不要用高速电介质的板材。使用此种材料时，MAX3983 的快速边沿会在 InfiniBand 和 CX4 电缆组件中产生过量的串扰。



图4. 使用相应的信号检测输出和使能输入实现自动检测



图5. 环回和自动检测模式

四通道铜缆信号调理器

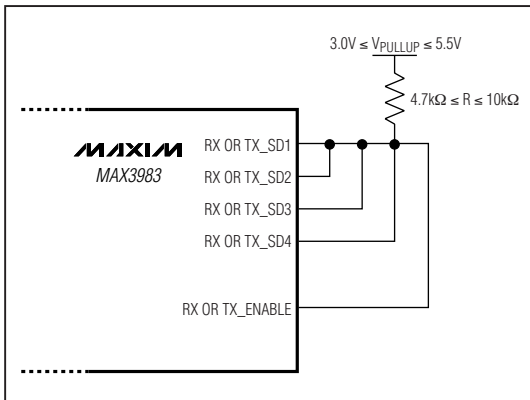
接口电路

MAX3983

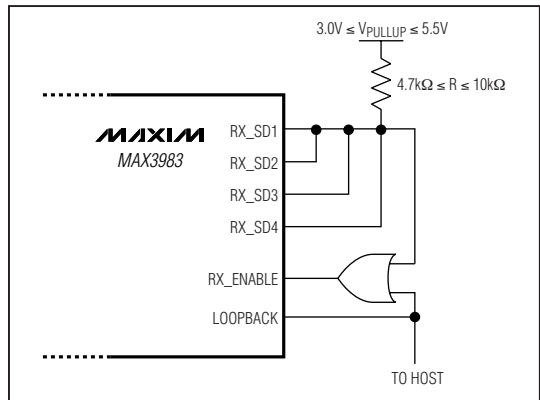
串扰

对于 InfiniBand 和 10Gbase-CX4 应用, 必须了解电缆组件的近端串扰特性。10Gbase-CX4 已规定了一个或多个侵入信号时, 近端串扰(NEXT)在整个频段的上限。InfiniBand 只是相对于发送器输出, 规定了一个在时域测得的百分比。无论采用何种方法规定, NEXT 对于链路性能来讲都是一项关键因素。当使用较大量的预加重时, 接收眼图高度会更小, 更容易发生串扰。在需要大级别发送预加重的情况下, NEXT 在 1GHz 至 3GHz 频段应低于 -30dB。需要注意的是, 满足 10Gbase-CX4 NEXT 和 MDNEXT 要求的电缆应该具有足够的隔离度。

布局考虑

电路板布局和设计会显著影响 MAX3983 的性能。数据信号通道应采用优良的高频设计技术, 尽量减小接地电感, 并使用控制阻抗的传输线。电源去耦应尽可能地靠近 V_{CC} 引脚。应该有足够的电源滤波。所有 V_{CC} 应连接到电源层。注意隔离输入与输出信号以免串扰。均衡器的性能在损耗环境中最优。为得到最佳性能, 应使用电介质损耗约为 0.02 的板材和 4mil 线宽的传输线。也可使用损耗小于 0.01 的高速板材, 但需要特别注意降低电缆组件的近端串扰。

裸露底座的封装

裸露底座的 68 引脚 QFN 封装为 IC 提供了一个热阻非常低的散热通道。这个底座是 MAX3983 的电气地, 必须焊接在电路板上以获得良好的热、电性能。有关裸露底座封装的更多信息, 请参考 Maxim 应用笔记 HFAN-08.1: *Thermal Considerations of QFN and Other Exposed-Paddle Packages*。



图6. RX_IN 和 TX_IN 等效输入结构



图7. RX_OUT 和 TX_OUT 等效输出结构

四通道铜缆信号调理器

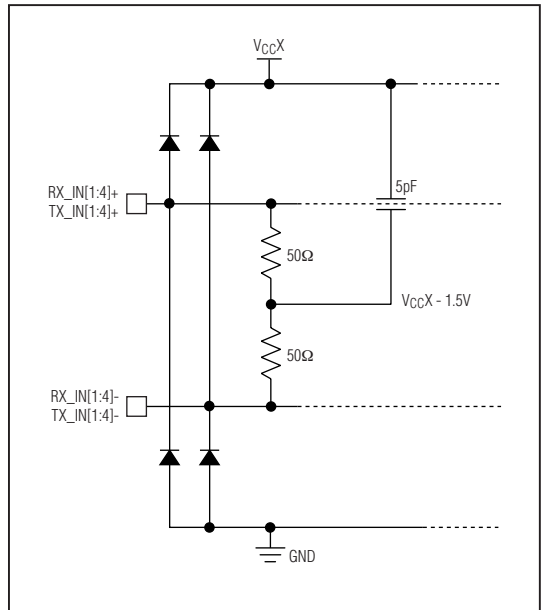

图8. LVTTTL 等效输入结构

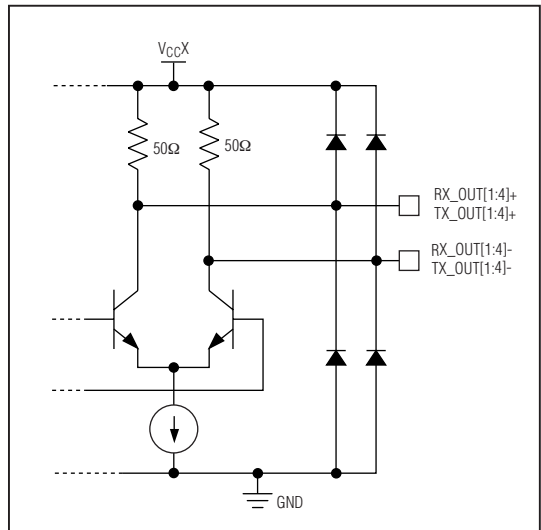

图9. 信号检测等效输出结构

四通道铜缆信号调理器

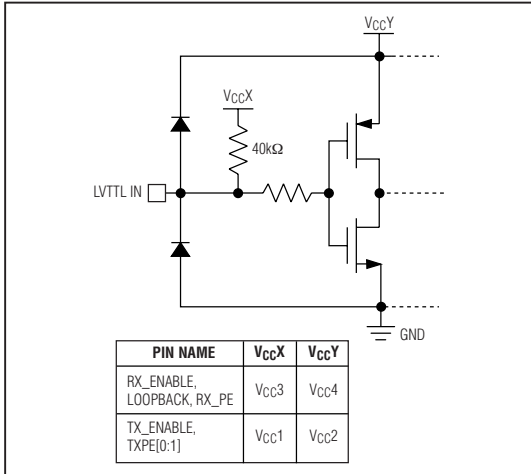
引脚配置

MAX3983

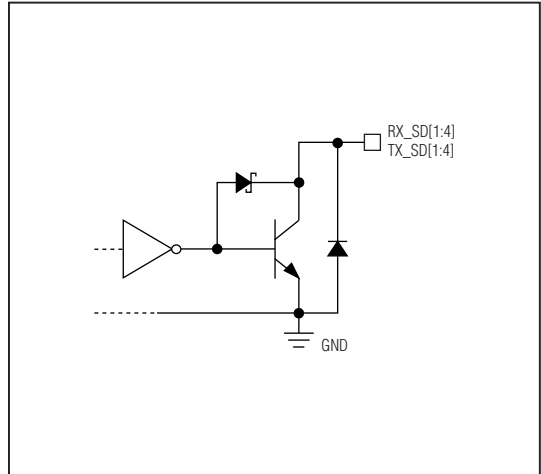
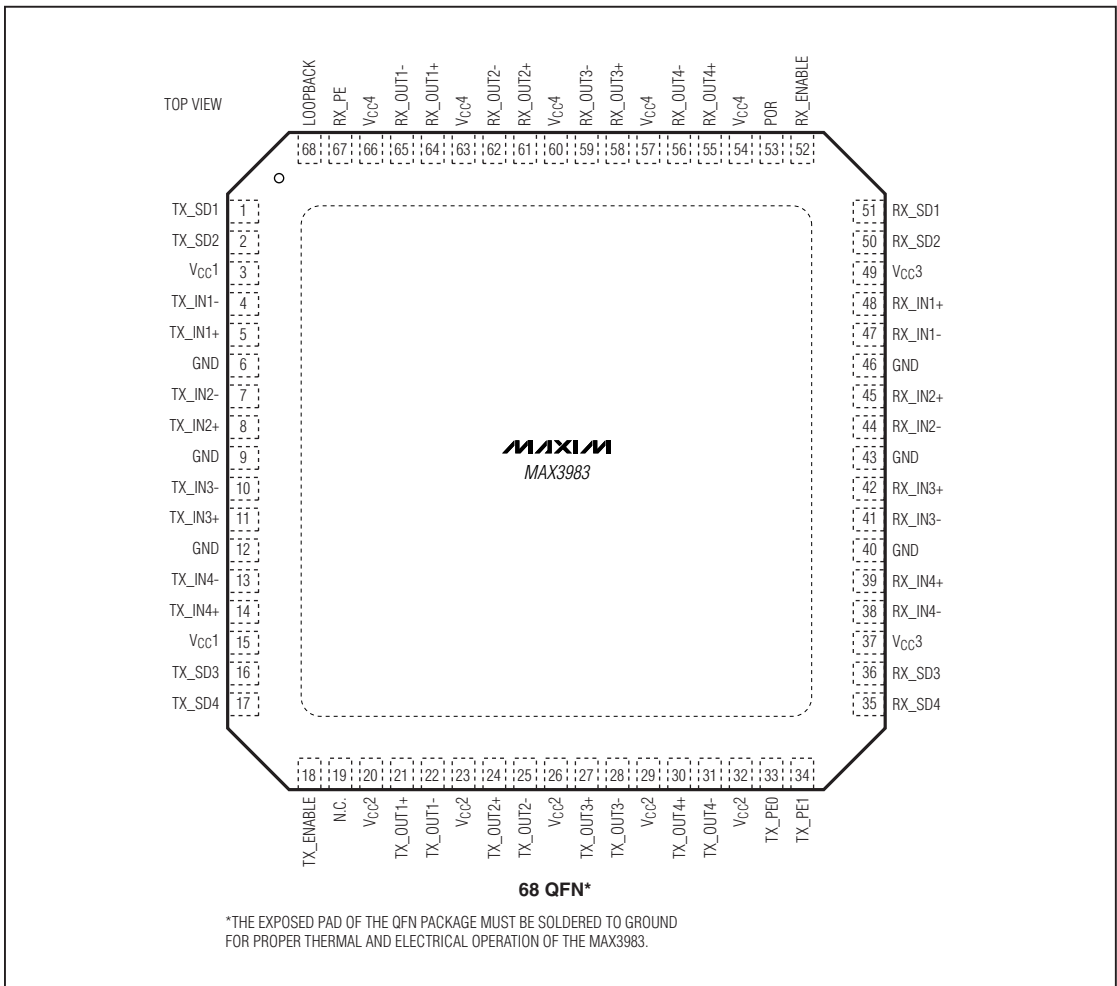

芯片信息

TRANSISTOR COUNT: 7493

PROCESS: SiGe Bipolar

四通道铜缆信号调理器

(本数据资料提供的封装图可能不是最近的规格, 如需最近的封装外型信息, 请查询 www.maxim-ic.com/packages.)

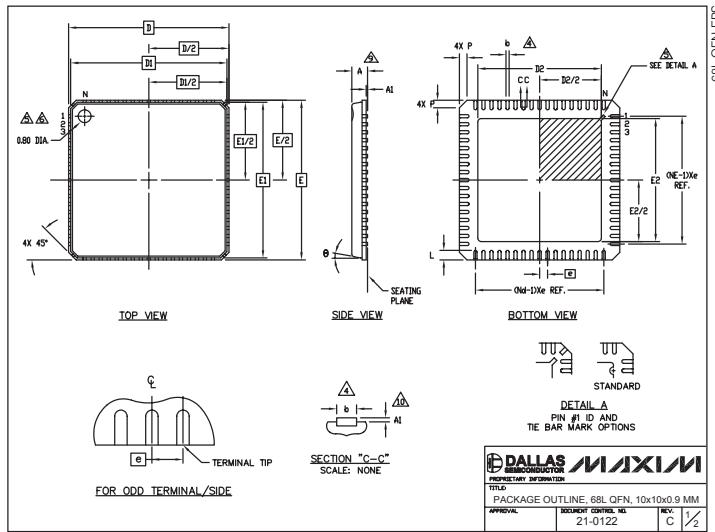

SYMBOL	COMMON DIMENSIONS			UNITS
	MIN.	NOM.	MAX.	
A	-	0.90	1.00	
AI	0.00	0.01	0.05	11
b	Q18	0.23	0.30	4
D		10.00	BSC	
D1		9.75	BSC	
G		0.50	BSC	
E		10.00	BSC	
E1		9.75	BSC	
L	0.50	0.60	0.65	
N		68		3
Nd		17		3
Ne		17		3
θ	0		12°	
P	0	0.42	0.60	

PKG CODE	D2			E2		
	MIN	NOM	MAX	MIN	NOM	MAX
G6800-2	7.55	7.70	7.85	7.55	7.70	7.85
G6800-4	5.65	5.80	5.95	5.65	5.80	5.95

- DIE THICKNESS ALLOWABLE IS .012 INCHES MAXIMUM.
- DIMENSIONING & TOLERANCES CONFORM TO ASME Y14.5M - 1994.
- N IS THE NUMBER OF TERMINALS.
- Nd IS THE NUMBER OF TERMINALS IN X-DIRECTION & Ne IS THE NUMBER OF TERMINALS IN Y-DIRECTION.
- DIMENSION b APPLIES TO PLATED TERMINAL AND IS MEASURED BETWEEN 0.20 AND 0.25mm FROM TERMINAL TIP.
- THE PIN #1 IDENTIFIER MUST BE LOCATED ON THE TOP SURFACE OF THE PACKAGE BY USING INDENTATION MARK OR OTHER FEATURE OF PACKAGE BODY. DETAILS OF PIN #1 IDENTIFIER IS OPTIONAL, BUT MUST BE LOCATED WITHIN ZONE INDICATED.
- EXACT SHAPE AND SIZE OF THIS FEATURE IS OPTIONAL.
- ALL DIMENSIONS ARE IN MILLIMETERS.
- PACKAGE WARPAGE MAX 0.10mm.
- APPLIES TO EXPOSED SURFACE OF PADS AND TERMINALS.
- APPLIES ONLY TO TERMINALS.
- MEETS JEDEC MO-220.

DALLAS MAXIM

PROPRIETARY INFORMATION

TITLE: PACKAGE OUTLINE: 68L QFN, 10x10x0.9 MM

APPROVAL: 21-0122

REV: C

1/2

Maxim 不对 Maxim 产品以外的任何电路使用负责, 也不提供其专利许可。Maxim 保留在任何时间、没有任何通报的前提下修改产品资料和规格的权利。