

## ADVANCE INFORMATION DATA SHEET

(Subject to change without notice)

April 3, 1995

8909

Data Sheet  
26301.10

## 3-PHASE BRUSHLESS DC MOTOR CONTROLLER/DRIVER WITH BACK-EMF SENSING AND POWER DMOS OUTPUTS

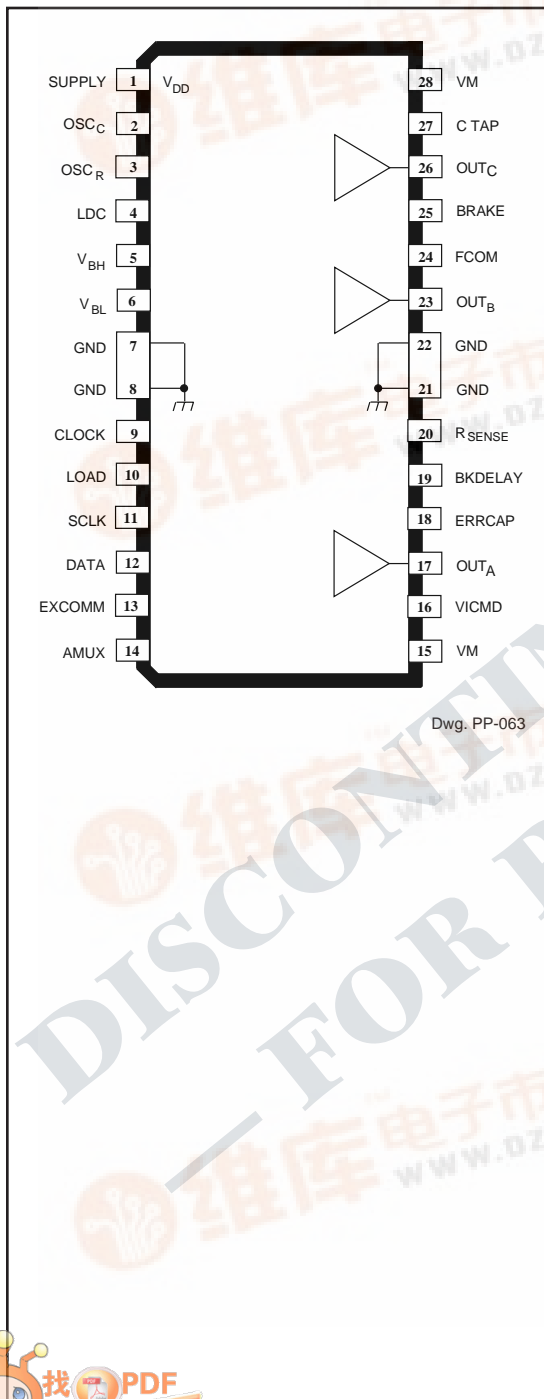

The A8909CLB is a three-phase brushless, back-EMF sensing, spindle-motor driver that integrates analog bipolar, analog and digital CMOS control functions, and DMOS power outputs on a single monolithic chip. It provides complete back-EMF sensing, commutation control, and drive of a spindle motor, and provides for an orderly spin-down in the event of supply-voltage removal. Energy for retracting the heads is regenerated from the spinning motor, while a controlled delay allows for a full retract before dynamic braking. The pulse-width modulation system and power DMOS outputs provide control of high currents with minimum power dissipation in the chip, and minimal average power supply current.

The internal sensorless commutation algorithm is based on earlier Allegro back-EMF sensing spindle-motor driver products that have proven capability. This system features digital adaptive commutation delay, programmable digital commutation timers, and minimal micro overhead during startup. This results in enhanced resynchronization during a power fault followed by a restart.

A serial peripheral interface provides control of programmable features and mode switches. An onboard dc-to-dc converter provides regulated boost voltage for both the high-side and sink-side gate-drive circuits. This provides for optimal  $r_{DS(on)}$  of sources and sinks, regardless of motor supply voltage (5 V or 12 V).

The A8909CLB is supplied in a 28-lead low-profile SOIC batwing power package for surface-mount applications.

### FEATURES

- 3 Half-Bridge DMOS Outputs with Low ON Resistance
- 5 V Logic Supply, 5 V or 12 V Motor Supply
- Back-EMF Sensing and Commutation Algorithm with Digital Programmable Timing Functions
- Adaptive Adjustable Digital Commutation Delay
- DC-to-DC Boost Voltage Generator for Source and Sink Gate Drive
- PWM Current-Control Loop with Sink-Side Chopping
- Transconductance Error Amp. with External Compensation for Average Supply Current Control Loop
- PWM Oscillator with External Frequency-Setting Components
- Current-Sense Amplifier
- Power-Down Brake with Delay Set by External RC
- Analog/Digital Multiplexer for Diagnostics and Testing
- Thermal Monitor Voltage Available on Multiplexer

# 8909

## 3-PHASE BRUSHLESS DC MOTOR CONTROLLER/DRIVER WITH BACK-EMF SENSING AND POWER DMOS OUTPUTS

- Back-EMF Zero-Crossing Output for Monitoring Motor Speed
- Sleep Mode
- Serial Port for Programming Modes, Multiplexer, & Programmable Timers

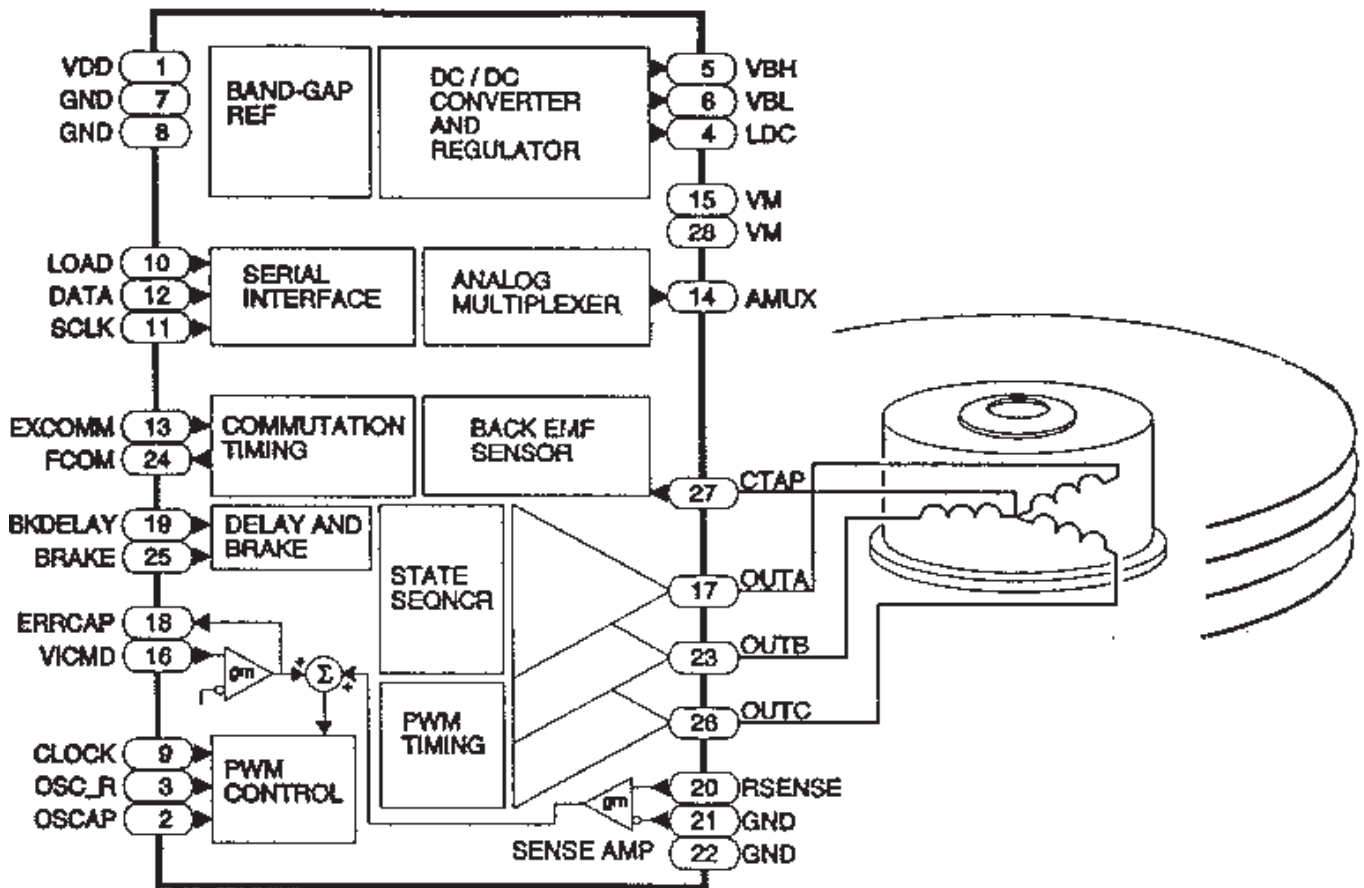

Dwg. FP-040