

19-1538; Rev 0; 9/99

EVALUATION KIT  
AVAILABLE

# MAXIM

## 1% Accurate, Digitally Trimmed, Rail-to-Rail Sensor Signal Conditioner

MAX1478

### General Description

The MAX1478 highly integrated, analog sensor signal processor is optimized for piezoresistive sensor calibration and compensation without any external components. It includes a programmable current source for sensor excitation, a 3-bit programmable-gain amplifier (PGA), a 128-bit internal EEPROM, and four 12-bit digital-to-analog converters (DACs). Achieving a total error factor within 1% of the sensor's repeatability errors, the MAX1478 compensates offset, offset temperature coefficient, full-span output (FSO), FSO temperature coefficient (FSO TC), and FSO nonlinearity of silicon piezoresistive sensors.

The MAX1478 calibrates and compensates first-order temperature errors by adjusting the offset and span of the input signal via DACs, thereby eliminating the quantization noise associated with digital signal path solutions. Built-in testability features on the MAX1478 result in the integration of three traditional sensor-manufacturing operations into one automated process:

- **Pretest:** Data acquisition of sensor performance under the control of a host test computer.
- **Calibration and compensation:** Computation and storage (in an internal EEPROM) of calibration and compensation coefficients computed by the test computer and downloaded to the MAX1478.
- **Final test operation:** Verification of transducer calibration and compensation without removal from the pretest socket.

Although optimized for use with piezoresistive sensors, the MAX1478 may also be used with other resistive sensors (i.e., accelerometers and strain gauges) with some additional external components.

### Customization

For high-volume applications, Maxim can customize the MAX1478 for unique requirements. With a dedicated cell library consisting of more than 90 sensor-specific functional blocks, Maxim can quickly provide customized MAX1478 solutions.

### Applications

- Piezoresistive Pressure and Acceleration Transducers and Transmitters
- Manifold Absolute Pressure (MAP) Sensors
- Automotive Systems
- Hydraulic Systems
- Industrial Pressure Sensors
- Strain-Gauge Sensors
- Industrial Temperature Sensors

### Features

- ◆ **Medium Accuracy ( $\pm 1\%$ ), Single-Chip Sensor Signal Conditioning**
- ◆ **Rail-to-Rail<sup>®</sup> Output**
- ◆ **Sensor Errors Trimmed Using Correction Coefficients Stored in Internal EEPROM—Eliminates Laser Trimming and Potentiometers**
- ◆ **Compensates Offset, Offset TC, FSO, FSO TC, and FSO Linearity**
- ◆ **Programmable Current Source (0.1mA to 2.0mA) for Sensor Excitation**
- ◆ **Fast Signal-Path Settling Time (<1ms)**
- ◆ **+5V Single Supply**
- ◆ **Accepts Sensor Outputs from +10mV/V to +40mV/V**
- ◆ **Fully Analog Signal Path**

### Pilot Production System

To simplify your pressure sensor design, Maxim has developed a fully automated pilot production system that will smooth the difficult transition from prototype to production. Details appear at the end of this data sheet.

### Ordering Information

PART	TEMP. RANGE	PIN-PACKAGE
MAX1478C/D	0°C to +70°C	Dice*
MAX1478AAE	-40°C to +125°C	16 SSOP

\*Dice are tested at  $T_A = +25^\circ\text{C}$ , DC parameters only.

Functional Diagram appears at end of data sheet.

### Pin Configuration

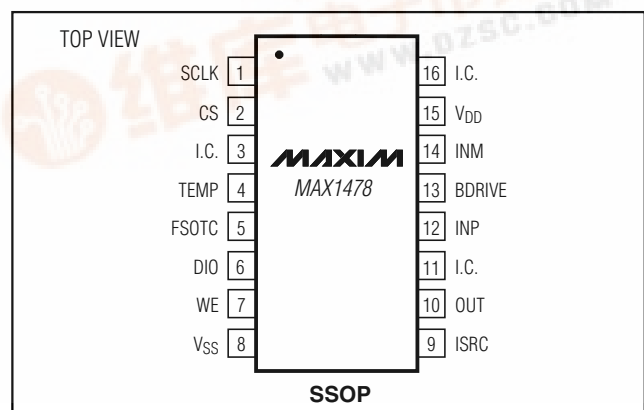

Rail-to-Rail is a registered trademark of Nippon Motorola, Ltd.

# 1% Accurate, Digitally Trimmed, Rail-to-Rail Sensor Signal Conditioner

## ABSOLUTE MAXIMUM RATINGS

Supply Voltage,  $V_{DD}$  to  $V_{SS}$ .....-0.3V to +6V  
 All Other Pins .....( $V_{SS} - 0.3V$ ) to ( $V_{DD} + 0.3V$ )  
 Short-Circuit Duration, FSOTC, OUT, BDRIVE.....Continuous  
 Continuous Power Dissipation ( $T_A = +70^\circ\text{C}$ )  
 16-Pin SSOP (derate 8.00mW/ $^\circ\text{C}$  above  $+70^\circ\text{C}$ ) .....640mW

Operating Temperature Range  
 MAX1478AAE .....-40 $^\circ\text{C}$  to +125 $^\circ\text{C}$   
 Storage Temperature Range .....-65 $^\circ\text{C}$  to +150 $^\circ\text{C}$   
 Lead Temperature (soldering, 10sec) .....+300 $^\circ\text{C}$

Stresses beyond those listed under "Absolute Maximum Ratings" may cause permanent damage to the device. These are stress ratings only, and functional operation of the device at these or any other conditions beyond those indicated in the operational sections of the specifications is not implied. Exposure to absolute maximum rating conditions for extended periods may affect device reliability.

## ELECTRICAL CHARACTERISTICS

( $V_{DD} = +5V$ ,  $V_{SS} = 0$ ,  $T_A = +25^\circ\text{C}$ , unless otherwise noted.)

PARAMETER	SYMBOL	CONDITIONS	MIN	TYP	MAX	UNITS
<b>GENERAL CHARACTERISTICS</b>						
Supply Voltage	$V_{DD}$		4.5	5.0	5.5	V
Supply Current	$I_{DD}$	(Note 1)		3	6	mA
<b>ANALOG INPUT (PGA)</b>						
Input Impedance	$R_{IN}$			1		$M\Omega$
Input-Referred Offset Tempco		(Notes 2, 3)		$\pm 0.5$		$\mu\text{V}/^\circ\text{C}$
Amplifier Gain Nonlinearity				0.01		% $V_{DD}$
Output Step Response		63% of final value		1		ms
Common-Mode Rejection Ratio	CMRR	From $V_{SS}$ to $V_{DD}$		90		dB
Input-Referred Adjustable Offset Range		At minimum gain (Note 4)		$\pm 150$		mV
Input-Referred Adjustable FSO Range		(Note 5)		10 to 40		mV/V
<b>ANALOG OUTPUT (PGA)</b>						
Differential-Signal Gain Range		Selectable in eight steps		41 to 230		V/V
Minimum Differential Signal Gain		$T_A = T_{MIN}$ to $T_{MAX}$	36	41	45	V/V
Differential-Signal Gain Tempco				$\pm 50$		ppm/ $^\circ\text{C}$
Output Voltage Swing		No load	$V_{SS} + 0.05$		$V_{DD} - 0.05$	V
Output Current Range		$V_{OUT} = (V_{SS} + 0.25V)$ to $(V_{DD} - 0.25V)$	-0.45 (sink)		0.45 (source)	mA
Output Noise		DC to 10Hz (gain = 41, source impedance = 5k $\Omega$ )		500		$\mu\text{VRMS}$

# 1% Accurate, Digitally Trimmed, Rail-to-Rail Sensor Signal Conditioner

**MAX1478**

## ELECTRICAL CHARACTERISTICS (continued)

(V<sub>DD</sub> = +5V, V<sub>SS</sub> = 0, T<sub>A</sub> = +25°C, unless otherwise noted.)

PARAMETER	SYMBOL	CONDITIONS	MIN	TYP	MAX	UNITS
<b>CURRENT SOURCE</b>						
Bridge Current Range	I <sub>BDRIVE</sub>		0.1	0.5	2.0	mA
Bridge Voltage Swing	V <sub>BDRIVE</sub>		V <sub>SS</sub> + 1.3		V <sub>DD</sub> - 1.3	V
Reference Input Voltage Range (ISRC)	V <sub>ISRC</sub>		V <sub>SS</sub> + 1.3		V <sub>DD</sub> - 1.3	V
<b>DIGITAL-TO-ANALOG CONVERTERS</b>						
DAC Resolution					12	Bits
Differential Nonlinearity	DNL			±1.5		LSB
Offset DAC Bit Weight	$\frac{\Delta V_{OUT}}{\Delta Code}$	DAC reference = V <sub>DD</sub> = 5.0V		2.8		mV/bit
Offset TC DAC Bit Weight	$\frac{\Delta V_{OUT}}{\Delta Code}$	DAC reference = V <sub>BDRIVE</sub> = 2.5V		1.4		mV/bit
FSO DAC Bit Weight	$\frac{\Delta V_{ISRC}}{\Delta Code}$	DAC reference = V <sub>DD</sub> = 5.0V		1.22		mV/bit
FSO TC DAC Bit Weight	$\frac{\Delta V_{FSOTC}}{\Delta Code}$	DAC reference = V <sub>BDRIVE</sub> = 2.5V		0.6		mV/bit
<b>IRO DAC</b>						
DAC Resolution				3		Bits
DAC Bit Weight		Input referred, V <sub>DD</sub> = 5V (Note 6)		9		mV/bit
<b>FSOTC BUFFER</b>						
Output Voltage Swing		No load	V <sub>SS</sub> + 0.3		V <sub>DD</sub> - 1.3	V
Current Drive		V <sub>FSOTC</sub> = 2.5V	-20		20	μA
<b>INTERNAL RESISTORS</b>						
Current-Source Reference Resistor	R <sub>ISRC</sub>			75		kΩ
FSO Trim Resistor	R <sub>FTC</sub>			75		kΩ
Temperature-Dependent Resistor	R <sub>TEMP</sub>	Typically 4600ppm/°C tempco		100		kΩ

**Note 1:** Excludes the sensor or load current.

**Note 2:** All electronics temperature errors are compensated together with sensor errors.

**Note 3:** The sensor and the MAX1478 must always be at the same temperature during calibration and use.

**Note 4:** This is the maximum allowable sensor offset.

**Note 5:** This is the sensor's sensitivity normalized to its drive voltage, assuming a desired full-span output of 4V and a bridge voltage of 2.5V.

**Note 6:** Bit weight is ratiometric to V<sub>DD</sub>.

# 1% Accurate, Digitally Trimmed, Rail-to-Rail Sensor Signal Conditioner

## Pin Description

PIN	NAME	FUNCTION
1	SCLK	Data Clock Input. Used only during programming/testing. Internally pulled to V <sub>SS</sub> with a 1M $\Omega$ (typical) resistor. Data is clocked in on the rising edge of the clock. The maximum SCLK frequency is 10kHz.
2	CS	Chip-Select Input. The MAX1478 is selected when this pin is high. When low, OUT and DIO become high impedance. Internally pulled to V <sub>DD</sub> with a 1M $\Omega$ (typical) resistor. Leave unconnected for normal operation.
3, 11, 16	I.C.	Internally Connected. Leave unconnected.
4	TEMP	Temperature Sensor Output. An internal temperature sensor (a 100k $\Omega$ , 4600ppm/ $^{\circ}$ C TC resistor) that can provide a temperature-dependent voltage.
5	FSOTC	Buffered FSOTC DAC Output. An internal 75k $\Omega$ resistor (R <sub>FTC</sub> ) connects FSOTC to ISRC (see <i>Functional Diagram</i> ). Optionally, external resistors can be used in place of or in parallel with R <sub>FTC</sub> and R <sub>ISRC</sub> .
6	DIO	Data Input/Output. Used only during programming/testing. Internally pulled to V <sub>SS</sub> with a 1M $\Omega$ (typical) resistor. High impedance when CS is low.
7	WE	Dual-Function Input Pin. Used to enable EEPROM erase/write operations. Also used to set the DAC refresh-rate mode. Internally pulled to V <sub>DD</sub> with a 1M $\Omega$ (typical) resistor. See the <i>Chip-Select (CS) and Write-Enable (WE)</i> section.
8	V <sub>SS</sub>	Negative Power-Supply Input
9	ISRC	Current-Source Reference. An internal 75k $\Omega$ resistor (R <sub>ISRC</sub> ) connects ISRC to V <sub>SS</sub> (see <i>Functional Diagram</i> ). Optionally, external resistors can be used in place of or in parallel with R <sub>FTC</sub> and R <sub>ISRC</sub> .
10	OUT	PGA Output Voltage
12	INP	Positive Sensor Input. Input impedance >1M $\Omega$ . Rail-to-rail input range.
13	BDRIVE	Sensor Excitation Current Output. This current source drives the bridge.
14	INM	Negative Sensor Input. Input impedance >1M $\Omega$ . Rail-to-rail input range.
15	V <sub>DD</sub>	Positive Power-Supply Input. Connect a 0.1 $\mu$ F capacitor from V <sub>DD</sub> to V <sub>SS</sub> .

## Detailed Description

The MAX1478 provides an analog amplification path for the sensor signal. Calibration and temperature compensation are achieved by varying the offset and gain of a programmable-gain amplifier (PGA) and by varying the sensor bridge current. The PGA uses a switched-capacitor CMOS technology, with an input-referred coarse offset trimming range of approximately  $\pm 63$ mV (9mV steps). An additional output-referred fine offset trim is provided by the Offset DAC (approximately 2.8mV steps). The PGA provides eight gain values from +41V/V to +230V/V. The bridge current source is programmable from 0.1mA to 2mA.

The MAX1478 uses four 12-bit DACs and one 3-bit DAC, with calibration coefficients stored by the user in

an internal 128-bit EEPROM. This memory contains the following information as 12-bit-wide words:

- Configuration register
- Offset calibration coefficient
- Offset temperature error-compensation coefficient
- FSO (full-span output) calibration coefficient
- FSO temperature error-compensation coefficient
- 24 user-defined bits for customer programming of manufacturing data (e.g., serial number and date)

Figure 1 shows a typical pressure-sensor output and defines the offset, full-scale, and FSO values as a function of voltage.

# 1% Accurate, Digitally Trimmed, Rail-to-Rail Sensor Signal Conditioner

## FSO TC Compensation

Silicon piezoresistive transducers (PRTs) exhibit a large positive input resistance tempco (TCR) so that, while under constant current excitation, the bridge voltage ( $V_{BDRIVE}$ ) increases with temperature. This dependence of  $V_{BDRIVE}$  on the sensor temperature can be used to compensate the sensor temperature errors. PRTs also have a large negative full-span output sensitivity tempco (TCS) so that, with constant voltage excitation, FSO will decrease with temperature, causing a full-span output temperature coefficient (FSO TC) error. However, if the bridge voltage can be made to increase with temperature at the same rate that TCS decreases with temperature, the FSO will remain constant.

FSO TC compensation is accomplished by resistor  $R_{FTC}$  and the FSOTC DAC, which modulate the excitation reference current at  $I_{SRC}$  as a function of temperature (Figure 3). FSO DAC sets  $V_{ISRC}$  and remains constant with temperature, while the voltage at FSOTC varies with temperature. FSOTC is the buffered output of the FSOTC DAC. The reference DAC voltage is  $V_{BDRIVE}$ , which is temperature dependent. The FSOTC DAC alters the tempco of the current source. When the tempco of the bridge voltage is equal in magnitude and opposite in polarity to the TCS, the FSO TC errors are compensated and FSO will be constant with temperature.

## Offset TC Compensation

Compensating offset TC errors involves first measuring the uncompensated offset TC error, then determining the percentage of the temperature-dependent voltage  $V_{BDRIVE}$  that must be added to the output summing

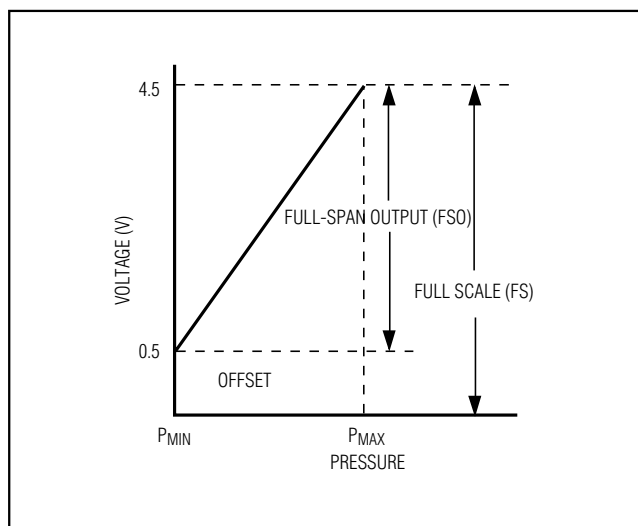

Figure 1. Typical Pressure-Sensor Output

junction to correct the error. Use the Offset TC DAC to adjust the amount of  $BDRIVE$  voltage that is added to the output summing junction (Figure 2).

## Analog Signal Path

The fully differential analog signal path consists of four stages:

- Front-end summing junction for coarse offset correction
- 3-bit PGA with eight selectable gains ranging from 41 through 230
- Three-input-channel summing junction
- Differential to single-ended output buffer (Figure 2)

## Coarse Offset Correction

The sensor output is first fed into a differential summing junction (INM (negative input) and INP (positive input)) with a CMRR >90dB, an input impedance of approximately  $1M\Omega$ , and a common-mode input voltage range from  $V_{SS}$  to  $V_{DD}$ . At this summing junction, a coarse offset-correction voltage is added, and the resultant voltage is fed into the PGA. The 3-bit (plus sign) input-referred Offset DAC (IRO DAC) generates the coarse offset-correction voltage. The DAC voltage reference is 1.25% of  $V_{DD}$ ; thus, a  $V_{DD}$  of 5V results in a front-end offset-correction voltage ranging from -63mV to +63mV, in 9mV steps (Table 1). To add an offset to the input signal, set the IRO sign bit high; to subtract an offset from the input signal, set the IRO sign bit low. The IRO DAC bits (C2, C1, C0, and IRO sign bit) are programmed in the configuration register (see *Internal EEPROM* section).

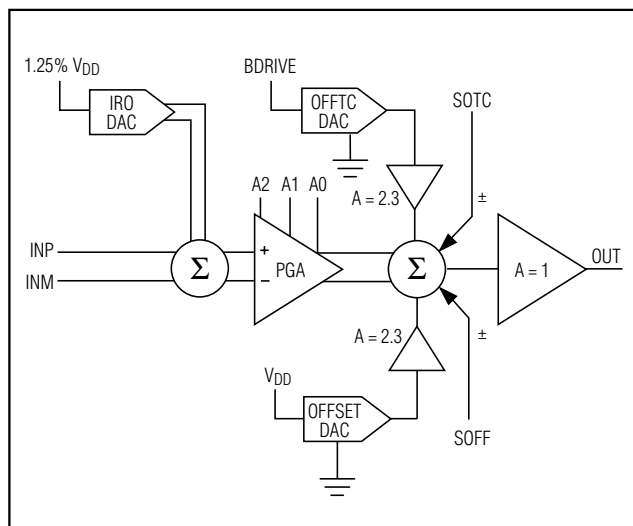

Figure 2. Signal-Path Block Diagram

# 1% Accurate, Digitally Trimmed, Rail-to-Rail Sensor Signal Conditioner

**Table 1. Input-Referred Offset DAC Correction Values**

IRO DAC					OFFSET CORRECTION % of V <sub>DD</sub> (%)	OFFSET CORRECTION AT V <sub>DD</sub> = 5V (mV)
VALUE	SIGN	C2	C1	C0		
+7	1	1	1	1	+1.25	+63
+6	1	1	1	0	+1.08	+54
+5	1	1	0	1	+0.90	+45
+4	1	1	0	0	+0.72	+36
+3	1	0	1	1	+0.54	+27
+2	1	0	1	0	+0.36	+18
+1	1	0	0	1	+0.18	+9
+0	1	0	0	0	0	0
-0	0	0	0	0	0	0
-1	0	0	0	1	-0.18	-9
-2	0	0	1	0	-0.36	-18
-3	0	0	1	1	-0.54	-27
-4	0	1	0	0	-0.72	-36
-5	0	1	0	1	-0.90	-45
-6	0	1	1	0	-1.08	-54
-7	0	1	1	1	-1.25	-63

### Programmable-Gain Amplifier

The PGA, which is used to set the coarse FSO, uses a switched-capacitor CMOS technology and contains eight selectable gain levels from 41 to 230, in increments of 27 (Table 2). The output of the PGA is fed to the output summing junction. The three PGA gain bits A2, A1, and A0 are stored in the configuration register.

### Output Summing Junction

The third stage in the analog signal path consists of a summing junction for the PGA output, offset correction, and offset TC correction. Both the offset and the offset TC correction voltages are multiplied by a factor of 2.3 before being fed into the summing junction, increasing the offset and offset TC correction range. The offset sign bit and offset TC sign bit are stored in the configuration register. The offset sign bit determines if the offset correction voltage is added to (sign bit is high) or subtracted from (sign bit is low) the PGA output. Negative offset TC errors require a logic high for the offset TC sign bit. Alternately, positive offset TC errors dictate a logic low for the offset TC sign bit. The output of the summing junction is fed to the output buffer.

**Table 2. PGA Gain Settings and IRO DAC Step Size**

PGA VALUE	A2	A1	A0	PGA GAIN (V/V)	OUTPUT-REFERRED IRO DAC STEP SIZE (V <sub>DD</sub> = 5V) (V)
0	0	0	0	41	0.369
1	0	0	1	68	0.612
2	0	1	0	95	0.855
3	0	1	1	122	1.098
4	1	0	0	149	1.341
5	1	0	1	176	1.584
6	1	1	0	203	1.827
7	1	1	1	230	2.070

### Output Buffer

OUT can drive 0.1μF of capacitance. The output is current limited and can be shorted to either V<sub>DD</sub> or V<sub>SS</sub> indefinitely. OUT can both source and sink current. A load can be driven to either rail. **The output can swing very close to either supply while maintaining its accuracy and stability.** Maxim recommends putting a 0.1μF capacitor on the OUT pin in noisy environments.

### Bridge Drive

Fine FSO correction is accomplished by varying the sensor excitation current with the 12-bit FSO DAC (Figure 3). Sensor bridge excitation is performed by a programmable current source capable of delivering up to 2mA. The reference current at ISRC is established by resistor R<sub>ISRC</sub> and by the voltage at node ISRC (controlled by the FSO DAC). The reference current flowing through this pin is multiplied by a current mirror (current mirror gain AA ≅ 14) and then made available at BDRIVE for sensor excitation. Modulation of this current with respect to temperature can be used to correct FSOTC errors, while modulation with respect to the output voltage (V<sub>OUT</sub>) can be used to correct FSO linearity errors.

### Digital-to-Analog Converters

The four 12-bit, sigma-delta DACs typically settle in less than 100ms. The four DACs have a corresponding memory register in EEPROM for storage of correction coefficients.

Use the FSO DAC for fine FSO adjustments. The FSO DAC takes its reference from V<sub>DD</sub> and controls V<sub>ISRC</sub> which, in conjunction with R<sub>ISRC</sub>, sets the baseline sensor excitation current. The Offset DAC also takes its reference from V<sub>DD</sub> and provides a 1.22mV resolution with

# 1% Accurate, Digitally Trimmed, Rail-to-Rail Sensor Signal Conditioner

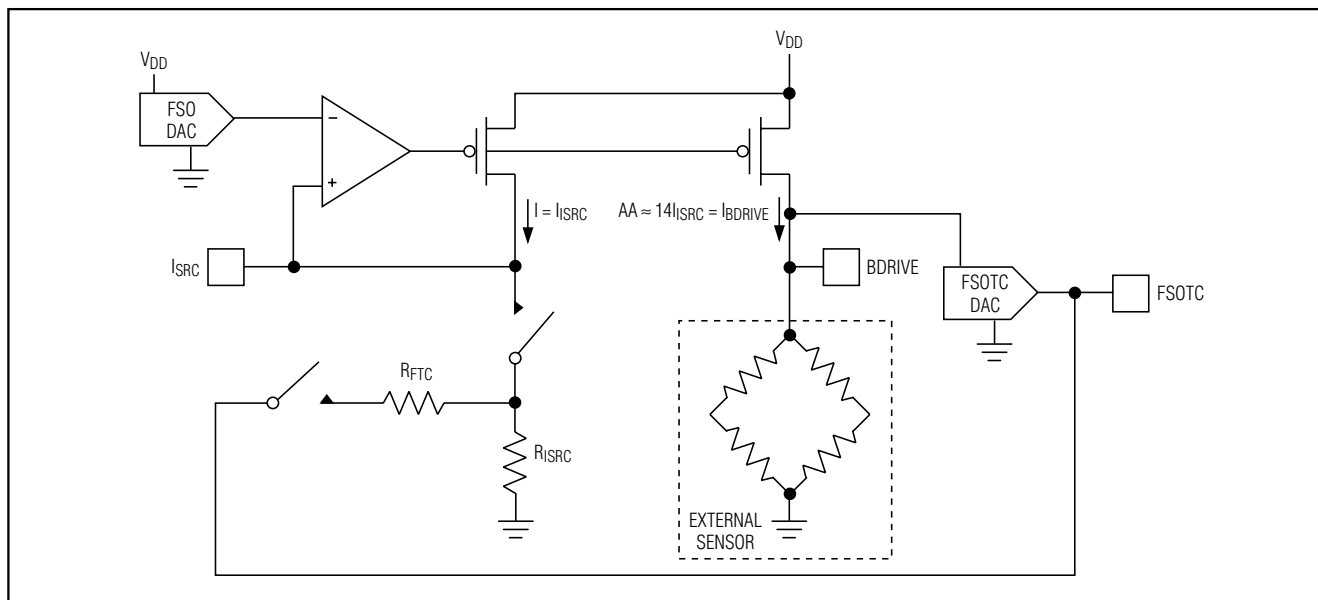

Figure 3. Bridge Excitation Circuit

a  $V_{DD}$  of 5V. The output of the Offset DAC is fed into the output summing junction where it is gained by approximately 2.3, which increases the resulting output-referred offset correction resolution to 2.8mV.

Both the Offset TC and FSOTC DACs take their reference from BDRIVE, a temperature-dependent voltage. A nominal  $V_{BDRIVE}$  of 2.5V results in a step size of 0.6mV. The Offset TC DAC output is fed into the output summing junction where it is multiplied by approximately 2.3, thereby increasing the Offset TC correction range. The buffered FSOTC DAC output is available at FSOTC and is connected to ISRC through  $R_{FTC}$  to correct FSO TC errors.

### Internal Resistors

The MAX1478 contains three internal resistors ( $R_{ISRC}$ ,  $R_{FTC}$ , and  $R_{TEMP}$ ) optimized for common silicon PRTs.  $R_{ISRC}$  (in conjunction with the FSO DAC) programs the nominal sensor excitation current.  $R_{FTC}$  (in conjunction with the FSOTC DAC) compensates the FSO TC errors. Both  $R_{ISRC}$  and  $R_{FTC}$  have a nominal value of 75k $\Omega$ . If external resistors are used,  $R_{ISRC}$  and  $R_{FTC}$  can be disabled by resetting the appropriate bit (address 07h reset to zero) in the configuration register (Table 3).

$R_{TEMP}$  is a high-tempco resistor with a TC of +4600ppm/ $^{\circ}$ C and a nominal resistance of 100k $\Omega$  at +25 $^{\circ}$ C. This resistor can be used with certain sensor types that require an external temperature sensor.

Table 3. Configuration Register

EEPROM ADDRESS (hex)	DESCRIPTION
00h	Offset TC Sign Bit, SOTC (+ = 1)
01h	Offset Sign Bit, SOFF (+ = 1)
02h	PGA Gain (MSB), A2
03h	PGA Gain, A1
04h	PGA Gain (LSB), A0
05h	Reserved "0"
06h	Reserved "0"
07h	Internal Resistor ( $R_{FTC}$ and $R_{ISRC}$ ) Selection
08h	Input-Referred Offset (IRO) Sign Bit
09h	Input-Referred Offset (MSB)
0Ah	Input-Referred Offset
0Bh	Input-Referred Offset (LSB)

### Internal EEPROM

The MAX1478 has a 128-bit internal EEPROM arranged as eight 16-bit words. The four uppermost bits for each register are reserved. The internal EEPROM is used to store the following (also shown in the memory map in Table 4):

# 1% Accurate, Digitally Trimmed, Rail-to-Rail Sensor Signal Conditioner

Table 4. EEPROM Memory Map

<b>EE Address</b>	0F	0E	0D	0C	0B	0A	09	08	07	06	05	04	03	02	01	00	
<b>Contents</b>	1	0	0	0	<b>Configuration</b>												
<b>EE Address</b>	1F	1E	1D	1C	1B	1A	19	18	17	16	15	14	13	12	11	10	
<b>Contents</b>	1	0	0	1	<b>MSB</b>				<b>Offset</b>								<b>LSB</b>
<b>EE Address</b>	2F	2E	2D	2C	2B	2A	29	28	27	26	25	24	23	22	21	20	
<b>Contents</b>	1	0	1	0	<b>MSB</b>				<b>Offset TC</b>								<b>LSB</b>
<b>EE Address</b>	3F	3E	3D	3C	3B	3A	39	38	37	36	35	34	33	32	31	30	
<b>Contents</b>	1	0	1	1	<b>MSB</b>				<b>FSO</b>								<b>LSB</b>
<b>EE Address</b>	4F	4E	4D	4C	4B	4A	49	48	47	46	45	44	43	42	41	40	
<b>Contents</b>	1	1	0	0	<b>MSB</b>				<b>FSOTC</b>								<b>LSB</b>
<b>Reserved*</b>	5F	5E	5D	5C	5B	5A	59	58	57	56	55	54	53	52	51	50	
	0	0	0	0	0	0	0	0	0	0	0	0	0	0	0	0	
<b>EE Address</b>	6F	6E	6D	6C	6B	6A	69	68	67	66	65	64	63	62	61	60	
<b>Contents</b>	0	0	0	0	<b>User-Defined Bits</b>												
<b>EE Address</b>	7F	7E	7D	7C	7B	7A	79	78	77	76	75	74	73	72	71	70	
<b>Contents</b>	0	0	0	0	<b>User-Defined Bits</b>												
	<div style="display: inline-block; width: 15px; height: 15px; background-color: #cccccc; border: 1px solid black;"></div> = Reserved Bits																

Note: The MAX1478 processes the Reserved Bits in the EEPROM. If these bits are not properly programmed, the configuration and DAC registers will not be updated correctly.

\*The contents of the Reserved EE Address 50–5F must all be reset to zero.

- Configuration register (Table 3)
- 12-bit calibration coefficients for the Offset and FSO DACs
- 12-bit compensation coefficients for the Offset TC and FSOTC DACs
- Two general-purpose registers available to the user for storing process information such as serial number, batch date, and check sums

Program the EEPROM 1 bit at a time. The bits have addresses from 0 to 127 (7F hex).

### Configuration Register

The configuration register (Table 3) determines the PGA gain, the polarity of the offset and offset TC coefficients, and the coarse offset correction (IRO DAC). It also enables/disables internal resistors (RFTC and RISRC).

### DAC Registers

The Offset, Offset TC, FSO, and FSOTC registers store the coefficients used by their respective calibration/compensation DACs.



# 1% Accurate, Digitally Trimmed, Rail-to-Rail Sensor Signal Conditioner

## Detailed Description of the Digital Lines

### Chip Select (CS) and Write Enable (WE)

CS is used to enable OUT, control serial communication, and force an update of the configuration and DAC registers.

- A low on CS disables serial communication.
- A transition from low to high on CS forces an update of the configuration and DAC registers from the EEPROM when the U bit is zero.
- A transition from high to low on CS terminates programming mode.
- A logic high on CS enables OUT and serial communication (see *Communication Protocol* section).

WE controls the refresh rate for the internal configuration and DAC registers from the EEPROM and enables the erase/write operations. If communication has been initiated (see *Communication Protocol* section), internal register refresh is disabled.

- A low on WE disables the erase/write operations and also disables register refreshing from the EEPROM.
- A high on WE selects a refresh rate of approximately 400 times per second and enables EEPROM erase/write operations.
- It is recommended that WE be connected to  $V_{SS}$  after the MAX1478 EEPROM has been programmed.

### Serial Clock

Serial Clock (SCLK) must be driven externally. It is used to input commands to the MAX1478 and read EEPROM contents. Input data on DIO is latched on the rising edge of SCLK. Noise on SCLK may disrupt communication. In noisy environments, place a capacitor (0.01 $\mu$ F) between SCLK and  $V_{SS}$ .

### Data Input/Output

The data input/output (DIO) line is an input/output pin used to issue commands to the MAX1478 (input mode) or read the EEPROM contents (output mode).

In input mode (the default mode), data on DIO is latched on each rising edge of SCLK. Therefore, data on DIO must be stable at the rising edge of SCLK and should transition on the falling edge of SCLK.

DIO will switch to output mode after receiving a READ EEPROM command, and will return the data bit addressed by the digital value in the READ EEPROM command. After a low-to-high transition on CS, DIO returns to input mode and is ready to accept more commands.

### Communication Protocol

To initiate communication, the first 6 bits on DIO after CS transitions from low to high **must** be 1010U0 (defined as the INIT SEQUENCE). The MAX1478 will then begin accepting 16-bit control words (Figure 4).

If the INIT SEQUENCE is not detected, all subsequent data on DIO is ignored until CS again transitions from low to high and the correct INIT SEQUENCE is received.

The U bit of the INIT SEQUENCE controls the updating of the DACs and configuration register from the internal EEPROM. If this bit is low ( $U = 0$ ), all four internal DACs and the configuration register will be updated from the EEPROM on the next rising edge of CS (this is also the default on power-up). If the U bit is high, the DACs and configuration register will not be updated from the internal EEPROM; they will retain their current value on any subsequent CS rising edge. The MAX1478 continues to accept control words until CS is brought low.

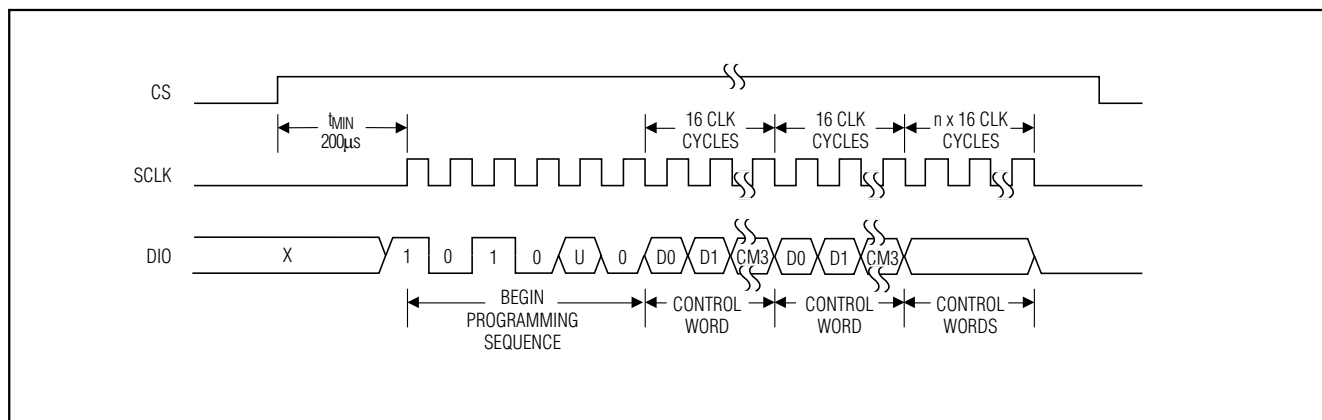

Figure 4. Communication Sequence

# 1% Accurate, Digitally Trimmed, Rail-to-Rail Sensor Signal Conditioner

## Control Words

After receiving the INIT SEQUENCE on DIO, the MAX1478 begins latching in 16-bit control words, LSB first (Figure 5). The first 12 bits (D0–D11) represent the data field. The last 4 bits of the control word (the MSBs, CM0–CM3) are the command field. The MAX1478 supports the commands listed in Table 5.

### ERASE EEPROM Command

When an ERASE EEPROM command is issued, all of the memory locations in the EEPROM are reset to a logic 0. The data field of the 16-bit word is ignored.

Important: An internal charge pump develops voltages greater than 20V for EEPROM programming operations. The EEPROM control logic requires 50ms to erase the EEPROM. After sending a WRITE or ERASE command, failure to wait 50ms before issuing another command may result in data being accidentally written to the EEPROM. The maximum number of ERASE EEPROM cycles should not exceed 100.

### BEGIN EEPROM WRITE Command

The BEGIN EEPROM WRITE command stores a logic high at the memory location specified by the lower 7 bits of the data field (A0–A6). The higher bits of the data field (A7–A11) are ignored (Figure 6). Note that to write to the internal EEPROM, WE and CS must be high.

Table 5. MAX1478 Commands

FUNCTION	HEX CODE	CM3	CM2	CM1	CM0
ERASE EEPROM	1h	0	0	0	1
BEGIN EEPROM WRITE at Address	2h	0	0	1	0
READ EEPROM at Address	3h	0	0	1	1
Maxim Reserved	4h	0	1	0	0
END EEPROM WRITE at Address	5h	0	1	0	1
WRITE Data to Configuration Register	8h	1	0	0	0
WRITE Offset DAC	9h	1	0	0	1
WRITE Offset TC DAC	Ah	1	0	1	0
WRITE FSO DAC	Bh	1	0	1	1
WRITE FSOTC DAC	Ch	1	1	0	0
No Operation	0h	0	0	0	0
Load Register	6h,	0	1	1	0
	7h,	0	1	1	1
	Dh,	1	1	0	1
	Eh,	1	1	1	0
	Fh	1	1	1	1

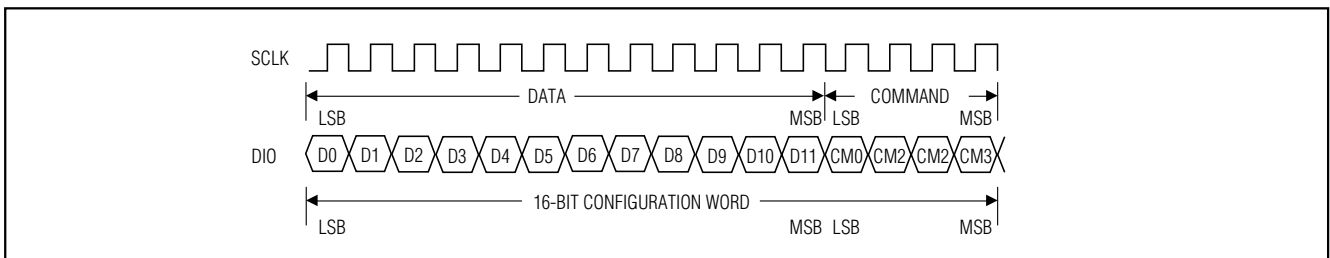

Figure 5. Control-Word Timing Diagram

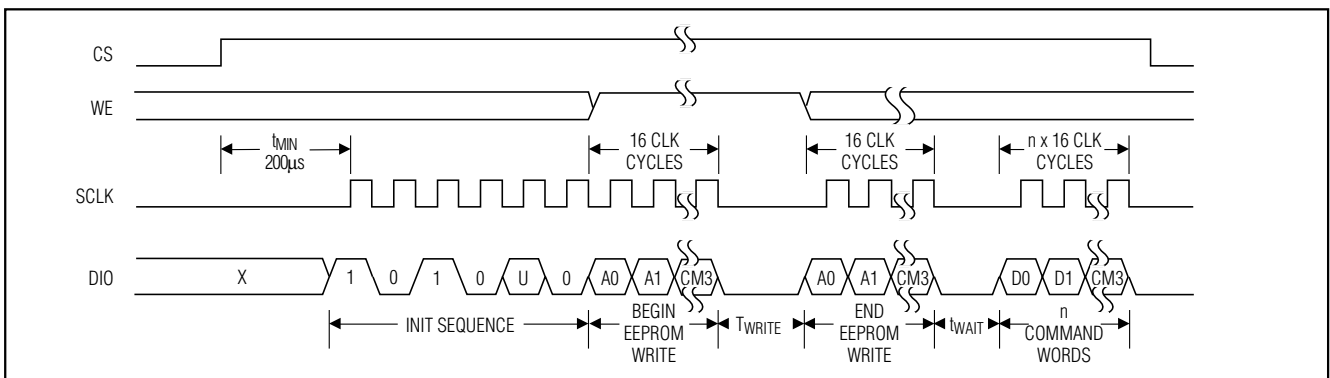

Figure 6. Timing Diagram for WRITE EEPROM Operation

# 1% Accurate, Digitally Trimmed, Rail-to-Rail Sensor Signal Conditioner

In addition, **the EEPROM should only be written to at  $T_A = +25^\circ\text{C}$  and  $V_{DD} = 5V$ .**

Writing to the internal EEPROM is a time-consuming process and should only be required once. All calibration/compensation coefficients are determined by writing directly to the DAC and configuration registers. Use the following procedure to write these calibration/compensation coefficients to the EEPROM:

- 1) Issue an ERASE EEPROM command.
- 2) Wait 50ms ( $t_{WRITE}$ ).
- 3) Issue an END EEPROM WRITE command at address 00h.
- 4) Wait 1ms ( $t_{WAIT}$ ).
- 5) Issue a BEGIN EEPROM WRITE command (Figure 7) at the address of the bit to be set.
- 6) Wait 50ms.
- 7) Issue an END EEPROM WRITE command (Figure 7) using the same address as in Step 5.

- 8) Wait 1ms.
- 9) Return to Step 5 until all necessary bits have been set.
- 10) Read EEPROM to verify that the correct calibration/compensation coefficients have been stored.

### READ EEPROM Command

The READ EEPROM command returns the bit stored at the memory location addressed by the lower 7 bits of the data field (A0–A6). The higher bits of the data field (A7–A11) are ignored. Note that after a read command has been issued, the DIO lines become an output and the state of the addressed EEPROM location will be available on DIO  $200\mu\text{s}$  ( $t_{READ}$ ) after the falling edge of the 16th SCLK cycle (Figure 8). After issuing the READ EEPROM command, DIO returns to input mode on the falling edge of CS. Reading the entire EEPROM requires the READ EEPROM command be issued 128 times.

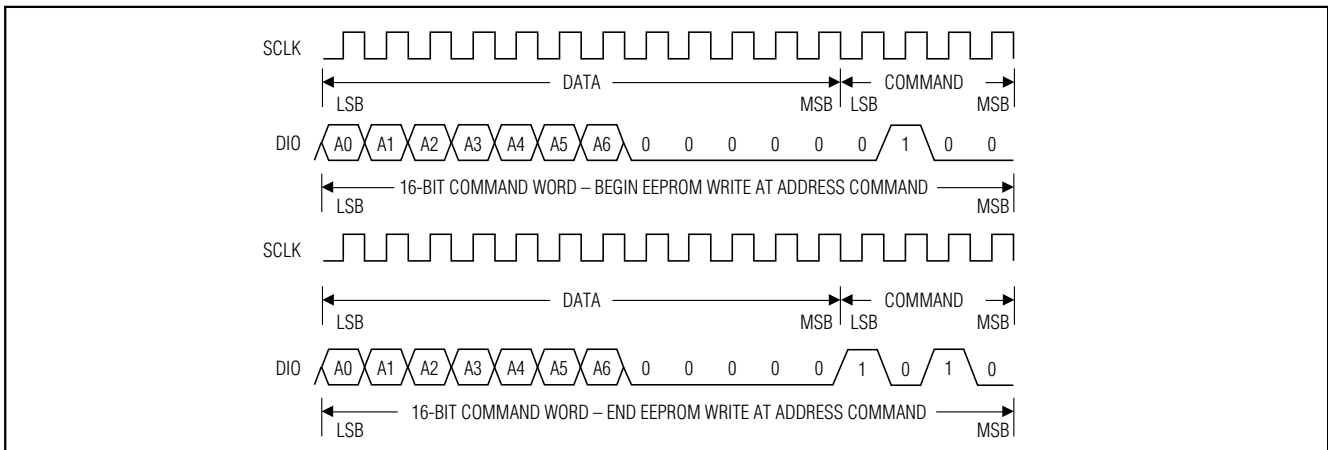

Figure 7. Begin WRITE EEPROM and End WRITE EEPROM Timing Diagrams

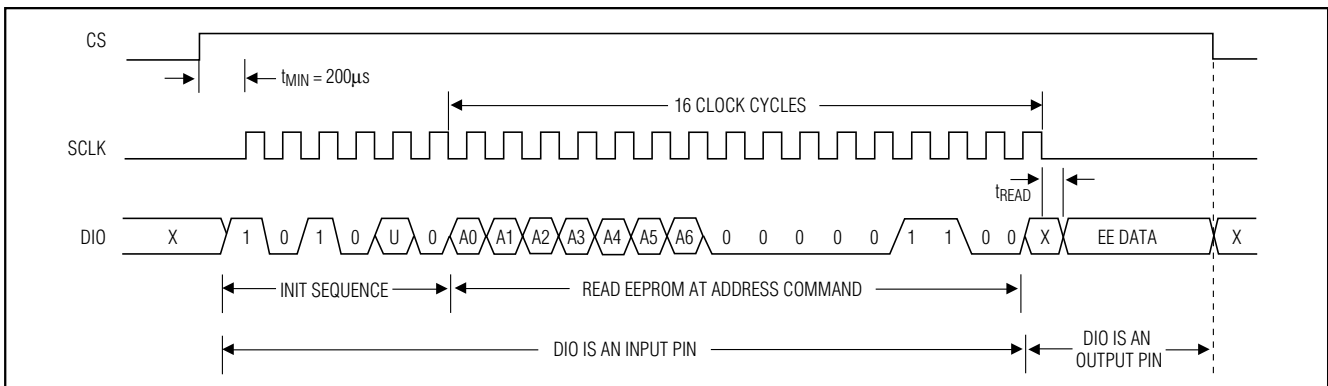

Figure 8. READ EEPROM Timing Diagram

# 1% Accurate, Digitally Trimmed, Rail-to-Rail Sensor Signal Conditioner

## Writing to the Configuration and DAC Registers

When writing to the configuration register or directly to the internal 12-bit DACs, the data field (D0–D11) contains the data to be written to the respective register. Note that all four DACs and the configuration register can be updated without toggling the CS line. Every register write command must be followed by a LOAD REGISTER command.

## Applications Information

### Power-Up

At power-up, the following occurs:

- 1) The DAC and configuration registers are reset to zero.
- 2) CS transitions from low to high after power-up (an internal pull-up resistor ensures that this happens if CS is left unconnected), and the EEPROM contents are read and processed.
- 3) The DAC and configuration registers are updated either once or approximately 400 times per second (as determined by the state of WE).
- 4) The MAX1478 begins accepting commands in a serial format on DIO immediately after receiving the INIT SEQUENCE.

The MAX1478 is shipped with all memory locations in the internal EEPROM uninitialized. Therefore, the MAX1478 **must** be programmed for proper operation.

### Compensation Procedure

The following compensation procedure was used to obtain the results shown in Figure 9 and Table 8. It assumes a pressure transducer with a +5V supply and an output voltage that is ratiometric to the supply voltage. The desired offset voltage ( $V_{OUT}$  at  $P_{MIN}$ ) is 0.5V, and the desired FSO voltage ( $V_{OUT(PMAX)} - V_{OUT(PMIN)}$ ) is 4V; thus, the full-scale output voltage ( $V_{OUT}$  at  $P_{MAX}$ ) will be 4.5V (see Figure 1). The procedure requires a minimum of two test pressures (e.g., zero and full scale) at two arbitrary test temperatures,  $T_1$  and  $T_2$ . Ideally,  $T_1$  and  $T_2$  are the two points where we wish to perform best linear fit compensation. The following outlines a typical compensation procedure:

- 1) Perform Coefficient Initialization
- 2) Perform FSO Calibration
- 3) Perform FSOTC Compensation
- 4) Perform Offset TC Compensation
- 5) Perform Offset Calibration

### Coefficient Initialization

Select the resistor values and the PGA gain to prevent overload of the PGA and bridge current source. These values depend on sensor behavior and require some sensor characterization data, which may be available from the sensor manufacturer. If not, the data can be generated by performing a two-temperature, two-pressure sensor evaluation. The required sensor information is shown in Table 6 and can be used to obtain the values for the parameters listed in Table 7.

**Table 6. Sensor Information for Typical PRT**

PARAMETER	SENSOR DESCRIPTION	TYPICAL VALUES
Rb(T)	Bridge Impedance	5k $\Omega$ at +25°C
TCR	Bridge Impedance Tempco	2600ppm/°C
S(T)	Sensitivity	+1.5mV/V per PSI at +25°C
TCS	Sensitivity Tempco	-2100ppm/°C
O(T)	Offset	+12mV/V at +25°C
OTC	Offset Tempco	-1000ppm/°C of FSO
S(p)	Sensitivity Linearity Error as % FSO, BSLF (Best Straight-Line Fit)	0.1% FSO, BSLF
P <sub>MIN</sub>	Minimum Input Pressure	0 psi
P <sub>MAX</sub>	Maximum Input Pressure	10 psi

### Selecting R<sub>ISRC</sub>

When using an external resistor, use the equation below to determine the value of  $R_{ISRC}$ , and place the resistor between  $I_{SRC}$  and  $V_{SS}$ . Since the 12-bit FSO DAC provides considerable dynamic range, the  $R_{ISRC}$  value need not be exact. Generally, any resistor value within  $\pm 50\%$  of the calculated value is acceptable. If both the internal resistors  $R_{ISRC}$  and  $R_{FTC}$  are used, set the IRS bit at EEPROM address bit 7 high. Otherwise, set IRS low and connect external resistors as shown in Figure 10.

$$R_{ISRC} \approx 14 \cdot R_b(T_1) \\ \approx 14 \cdot 5k\Omega = 70k\Omega$$

where  $R_b(T)$  is the sensor input impedance at temperature  $T_1$  (+25°C in this example).

# 1% Accurate, Digitally Trimmed, Rail-to-Rail Sensor Signal Conditioner

**Table 7. Compensation Components and Values**

PARAMETER	DESCRIPTION
R <sub>ISRC</sub>	Internal (approximately 75kΩ) or user-supplied resistor that programs the nominal sensor excitation current
R <sub>FTC</sub>	Internal (approximately 75kΩ) or user-supplied resistor that compensates FSO TC errors
A <sub>PGA</sub>	Programmable-gain amplifier gain
I <sub>RO</sub>	Input-referred offset correction DAC value
I <sub>RO</sub> Sign	Input-referred offset sign bit
I <sub>RS</sub>	Internal resistor selection bit
OFF COEF	Offset-correction DAC coefficient
OFF Sign	Offset sign bit
OFFTC COEF	Offset TC compensation DAC coefficient
OFFTC Sign	Offset TC sign bit
FSO COEF	FSO trim DAC coefficient
FSOTC COEF	FSO TC compensation DAC coefficient

### Selecting R<sub>FTC</sub>

When using an external resistor, use the equation below to determine the value for R<sub>FTC</sub>, and place the resistor between ISRC and FSOTC. Since the 12-bit FSOTC DAC provides considerable dynamic range, the R<sub>FTC</sub> value need not be exact. Generally, any resistor value within ±50% of the calculated value is acceptable.

$$R_{FTC} \cong \frac{R_{ISRC} \cdot 500\text{ppm}/^{\circ}\text{C}}{\text{TCR} - |\text{TCS}|}$$

$$\cong \frac{70\text{k}\Omega \cdot 500\text{ppm}/^{\circ}\text{C}}{2600\text{ppm}/^{\circ}\text{C} - |-2100\text{ppm}/^{\circ}\text{C}|} = 70\text{k}\Omega$$

This approximation works best for bulk, micromachined, silicon PRTs. Negative values for R<sub>FTC</sub> indicate unconventional sensor behavior that cannot be compensated by the MAX1478 without additional external circuitry.

### Selecting the PGA Gain Setting

To select the PGA gain setting, first calculate SensorFSO, the sensor full-span output voltage at T1:

$$\begin{aligned} \text{SensorFSO} &= S \cdot V_{\text{BDRIVE}} \cdot \Delta P \\ &= 1.5\text{mV/V per PSI} \cdot 2.5\text{V} \cdot 10\text{ PSI} \\ &= 0.0375\text{V} \end{aligned}$$

where S is the sensor sensitivity at T1, V<sub>BDRIVE</sub> is the sensor excitation voltage (initially 2.5V), and ΔP is the maximum pressure differential.

Then calculate the ideal gain using the following formula and select the nearest gain setting from Table 2:

$$\begin{aligned} A_{\text{PGA}} &= \frac{\text{OUTFSO}}{\text{SensorFSO}} \\ &= \frac{4\text{V}}{0.0375\text{V}} = +106\text{V/V} \end{aligned}$$

where OUTFSO is the desired calibrated transducer full-span output voltage, and SensorFSO is the sensor full-span output voltage at T1.

In this example, a PGA value of 2 (gain of +95V/V) is the best selection.

### Determining Input-Referred OFFSET

The input-referred offset (IRO) register is used to null any front-end sensor offset errors prior to amplification by the PGA. This reduces the possibility of saturating the PGA and maximizes the useful dynamic range of the PGA (particularly at the higher gain values).

First, calculate the ideal IRO correction voltage using the following formula, and select the nearest setting from Table 1:

$$\begin{aligned} \text{IRO}_{\text{ideal}} &= -[O(T1) \cdot V_{\text{BDRIVE}}(T1)] \\ &= -(0.012\text{V/V}) \cdot 2.5\text{V} \\ &= -30\text{mV} \end{aligned}$$

where IRO<sub>ideal</sub> is the exact voltage required to perfectly null the sensor, O(T1) is the sensor offset voltage in V/V at +25°C, and V<sub>BDRIVE</sub>(T1) is the nominal sensor excitation voltage at +25°C. In this example, 30mV must be subtracted from the amplifier front end to null the sensor perfectly. From Table 1, select an IRO value of 3 to set the IRO DAC to 27mV, which is nearest the ideal value. To subtract this value, set the IRO sign bit to 0. The residual output-referred offset error will be corrected later with the Offset DAC.

### Determining OFFTC COEF Initial Value

Generally, OFFTC COEF can initially be set to 0 since the offset TC error will be compensated in a later step. However, sensors with large offset TC errors may require an initial coarse offset TC adjustment to prevent the PGA from saturating during the compensation procedure as temperature is increased. An initial coarse offset TC adjustment is required for sensors with an offset TC greater than about 10% of the FSO. If an initial

# 1% Accurate, Digitally Trimmed, Rail-to-Rail Sensor Signal Conditioner

coarse offset TC adjustment is required, use the following equation:

$$\begin{aligned} \text{OFFTC COEF} &= \frac{4096 \cdot \Delta V_{\text{OUT}}(T)}{\Delta V_{\text{BDRIVE}}(T) \cdot 2.3} \\ &\cong \frac{4096 (\text{OTC} \cdot \text{FSO}) \cdot \Delta T}{\text{TCS} \cdot V_{\text{BDRIVE}} \cdot 2.3 \cdot \Delta T} \\ &= \frac{4096 (-1000\text{ppm}/^{\circ}\text{C} \cdot 4\text{V})}{-2100\text{ppm}/^{\circ}\text{C} \cdot 2.5\text{V} \cdot 2.3} = 1357 \end{aligned}$$

where OTC is the sensor offset TC error as a ppm/°C of OUTFSO (Table 6),  $\Delta T$  is the operating temperature range in °C, and OFFTC COEF is the numerical decimal value to be loaded into the DAC. For positive values, set the OFFTC sign bit high; for negative values, set the OFFTC sign bit low. If the absolute value of the OFFTC COEF is larger than 4096, the sensor has a very large offset TC error that the MAX1478 is unable to completely correct.

## FSO Calibration

Perform FSO calibration at room temperature with a full-scale sensor excitation.

- 1) Set FSOTC COEF to 1000.
- 2) At T1, adjust FSO DAC until  $V_{\text{BDRIVE}}$  is about 2.5V.
- 3) Adjust Offset DAC (and OFFSET sign bit, if needed) until the T1 offset voltage is 0.5V (see *OFFSET Calibration* section).
- 4) Measure the full-span output ( $\text{measured}V_{\text{FSO}}$ ).
- 5) Calculate the ideal bridge voltage,  $V_{\text{BIDEAL}}(T1)$ , using the following equation:

$$V_{\text{BIDEAL}}(T1) = V_{\text{BDRIVE}} \cdot \left( 1 + \frac{\text{desired}V_{\text{FSO}} - \text{measured}V_{\text{FSO}}(T1)}{\text{measured}V_{\text{FSO}}(T1)} \right)$$

**Note:** If  $V_{\text{BIDEAL}}(T1)$  is outside the allowable bridge voltage swing of ( $V_{\text{SS}} + 1.3\text{V}$ ) to ( $V_{\text{DD}} - 1.3\text{V}$ ), readjust the PGA gain setting. If  $V_{\text{BIDEAL}}(T1)$  is too low, decrease the PGA gain setting by one step and return to Step 2. If  $V_{\text{BIDEAL}}(T1)$  is too high, increase the PGA gain setting by one step and return to Step 2.

- 6) Set  $V_{\text{BIDEAL}}(T1)$  by adjusting the FSO DAC.
- 7) Readjust Offset DAC until the offset voltage is 0.5V (see *OFFSET Calibration* section).

## Three-Step FSOTC Compensation

### Step 1

Use the following procedure to determine FSOTC COEF; four variables, A–D, will be used:

- 1) Name the existing FSO DAC coefficient A.
- 2) Change FSOTC DAC to 3000.
- 3) Adjust FSO DAC until  $V_{\text{BDRIVE}}(T1)$  is equal to  $V_{\text{BIDEAL}}(T1)$ .
- 4) Name the existing FSO DAC coefficient B.
- 5) Readjust the offset voltage (by adjusting the Offset DAC), if required, to 0.5V.

At this point, it is important that no other changes be made to the Offset or Offset TC DACs until the Offset TC Compensation step has been completed.

### Step 2

To complete linear FSOTC compensation, take data measurements at a second temperature, T2 ( $T2 > T1$ ). Perform the following steps:

- 1) Measure the full-span output ( $\text{measured}V_{\text{FSO}}(T2)$ ).
- 2) Calculate  $V_{\text{BIDEAL}}(T2)$  using the following equation:

$$V_{\text{BIDEAL}}(T2) = V_{\text{BDRIVE}} \cdot \left( 1 + \frac{\text{desired}V_{\text{FSO}} - \text{measured}V_{\text{FSO}}(T2)}{\text{measured}V_{\text{FSO}}(T2)} \right)$$

- 3) Set  $V_{\text{BIDEAL}}(T2)$  by adjusting the FSO DAC.
- 4) Name the current FSO DAC coefficient D.
- 5) Change FSOTC DAC to 1000.
- 6) Adjust FSO DAC until  $V_{\text{BDRIVE}}$  is equal to  $V_{\text{BIDEAL}}(T2)$ .
- 7) Name the FSO DAC coefficient C.

### Step 3

Insert the data previously obtained from Steps 1 and 2 into the following equation to calculate FSOTC COEF:

$$\text{FSOTC COEF} = \frac{1000(B - D) + 3000(C - A)}{(B - D) + (C - A)}$$

- 1) Load this FSOTC COEF value into the FSOTC DAC.
- 2) Adjust the FSO DAC until  $V_{\text{BDRIVE}}(T2)$  is equal to  $V_{\text{BIDEAL}}(T2)$ .

This completes both FSO calibration and FSO TC compensation.

# 1% Accurate, Digitally Trimmed, Rail-to-Rail Sensor Signal Conditioner

### Offset TC Compensation

The offset voltage at T1 was previously set to 0.5V; therefore, any variation from this voltage at T2 is an offset TC error. Perform the following steps:

- 1) Measure the offset voltage at T2.
- 2) Use the following equation to compute the correction required:

$$\text{NewOFFTC COEF} = \text{CurrentOFFTC COEF} - \left( \frac{4096 \left[ V_{\text{OFFSET}}(T1) - V_{\text{OFFSET}}(T2) \right]}{2.3 \left[ V_{\text{BDRIVE}}(T1) - V_{\text{BDRIVE}}(T2) \right]} \right)$$

**Note:** CurrentOFFTC COEF is the current value stored in the Offset TC DAC. If the Offset TC sign bit (SOTC) is low, this number is negative.

- 3) Load this value into the Offset TC DAC.

- 4) If NewOFFTC COEF is negative, set the SOTC bit low; otherwise, set it high.

Offset TC compensation is now complete.

### Offset Calibration

At this point, the sensor should still be at temperature T2. The final offset adjustment can be made at T2 or T1 by adjusting the Offset DAC (and optionally the offset sign bit, SOFF) until the output ( $V_{\text{OUT(PMIN)}}$ ) reads 0.5V at zero input pressure. Use the following procedure:

- 1) Set Offset DAC to zero (Offset COEF = 0).
- 2) Measure the voltage at OUT.
- 3) If  $V_{\text{OUT}}$  is greater than the desired offset voltage (0.5V in this example), set SOFF low; otherwise, set it high.
- 4) Increase Offset COEF until  $V_{\text{OUT}}$  equals the desired offset voltage.

Offset calibration is now complete. Table 8 and Figure 9 compare an uncompensated input to a typical compensated transducer output.

**Table 8. MAX1478 Calibration and Compensation**

Typical Uncompensated Input (Sensor)	Typical Compensated Transducer Output
Offset .....±80% FSO	$V_{\text{OUT}}$ .....Ratiometric to $V_{\text{DD}}$ at 5.0V
FSO .....+15mV/V	Offset at +25°C .....0.500V ±5mV
Offset TC .....-17% FSO	FSO at +25°C .....4.000V ±5mV
Offset TC Nonlinearity .....0.7% FSO	Offset Accuracy Over Temp Range .....±28mV (±0.7% FSO)
FSO TC .....-35% FSO	FSO Accuracy Over Temp Range .....±20mV (±0.5% FSO)
FSO TC Nonlinearity .....0.5% FSO	
Temperature Range.....-40°C to +125°C	

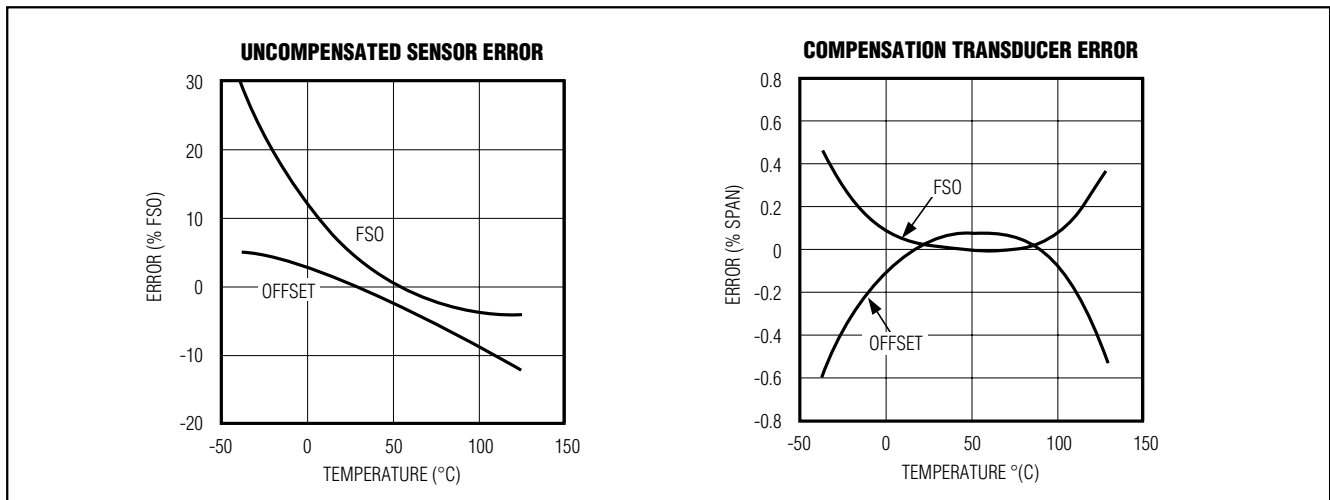

Figure 9. Comparison of an Uncalibrated Sensor and a Temperature-Compensated Transducer

# 1% Accurate, Digitally Trimmed, Rail-to-Rail Sensor Signal Conditioner

## Ratiometric Output Configuration

Ratiometric output configuration provides an output that is proportional to the power-supply voltage. When used with ratiometric A/D converters, this output provides digital pressure values independent of supply voltage. Most automotive and some industrial applications require ratiometric outputs.

The MAX1478 provides a high-performance ratiometric output with a minimum number of external components (Figure 10). These external components include the following:

- One power-supply bypass capacitor (C1)
- Two optional resistors, one from FSOTC to ISRC, and another from ISRC to V<sub>SS</sub>, depending on the sensor type
- One optional capacitor (C2) from BDRIVE to V<sub>SS</sub>

## Test System Configuration

The MAX1478 is designed to support an automated production pressure-temperature test system with integrated calibration and temperature compensation. Figure 11 shows the implementation concept for a low-cost test system capable of testing up to 12 transducer modules connected in parallel. The test system shown in Figure 11 includes a dedicated test bus consisting of four wires:

- Two power-supply lines
- Two serial-interface lines: DIO (input/output) and SCLK (clock)
- An individual V<sub>OUT</sub> line

For simultaneous testing of more than 12 sensor modules, use buffers to prevent overloading the data bus. A digital multiplexer controls the chip-select signal for each transducer.

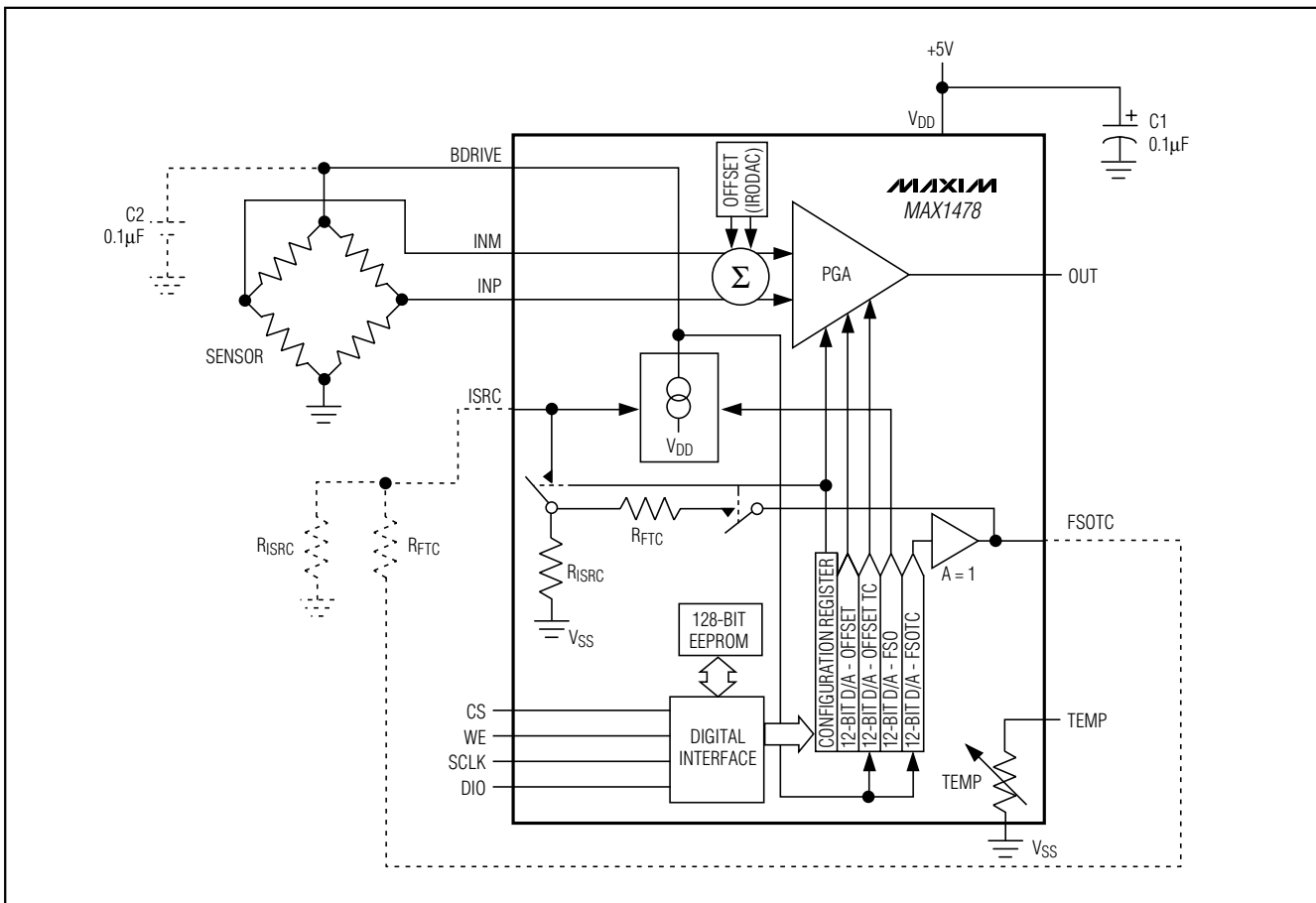

Figure 10. Basic Ratiometric Output Configuration



# 1% Accurate, Digitally Trimmed, Rail-to-Rail Sensor Signal Conditioner

**MAX1478**

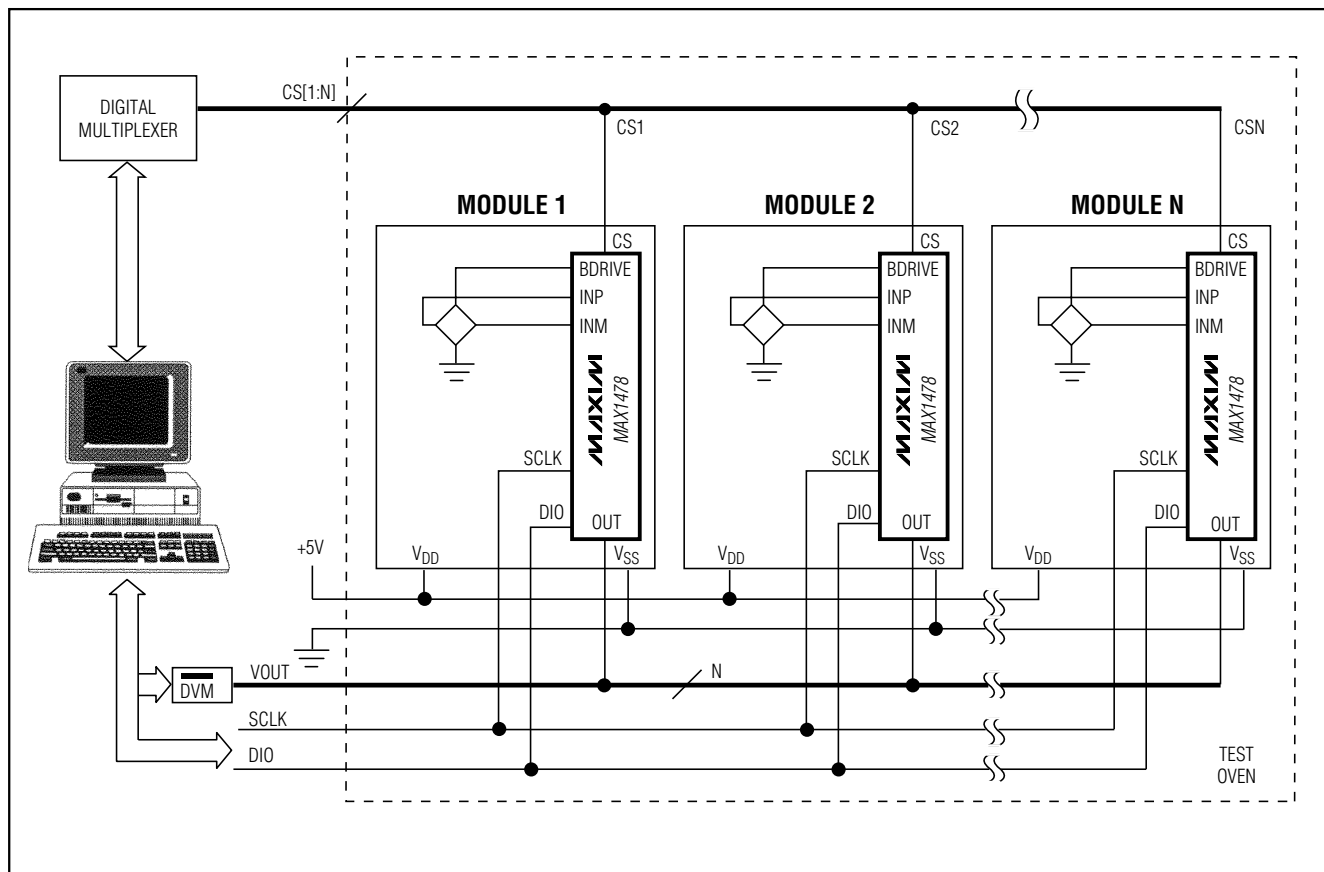

Figure 11. Automated Test System Concept

## MAX1478 Evaluation Development Kit

To expedite the development of MAX1478-based transducers and test systems, Maxim has produced the MAX1478 evaluation kit (EV kit). *First-time users of the MAX1478 are strongly encouraged to use this kit.* The MAX1478 EV kit is designed to facilitate manual programming of the MAX1478 and includes the following:

- 1) **Evaluation Board** with a silicon pressure sensor.
- 2) **Design/Applications Manual**, which describes in detail the architecture and functionality of the MAX1478. This manual was developed for test engineers familiar with data acquisition of sensor data and provides sensor compensation algorithms and test procedures.

- 3) **MAX1478 Communication Software**, which enables programming of the MAX1478 from a computer (IBM compatible), one module at a time.
- 4) **Interface Adapter and Cable**, which allow the connection of the evaluation board to a PC parallel port.

## MAX1478 Pilot Production System

For volume applications, Maxim has developed a fully automated pilot production system. The system consists of the Maxim 14XXDASBOARD and one or more 14XXMUXBOARD modules, a DVM, an environmental chamber, and a pressure controller. Only the 14XXDASBOARD and the 14XXMUXBOARD modules are available through Maxim. The user must acquire the

# 1% Accurate, Digitally Trimmed, Rail-to-Rail Sensor Signal Conditioner

## Functional Diagram

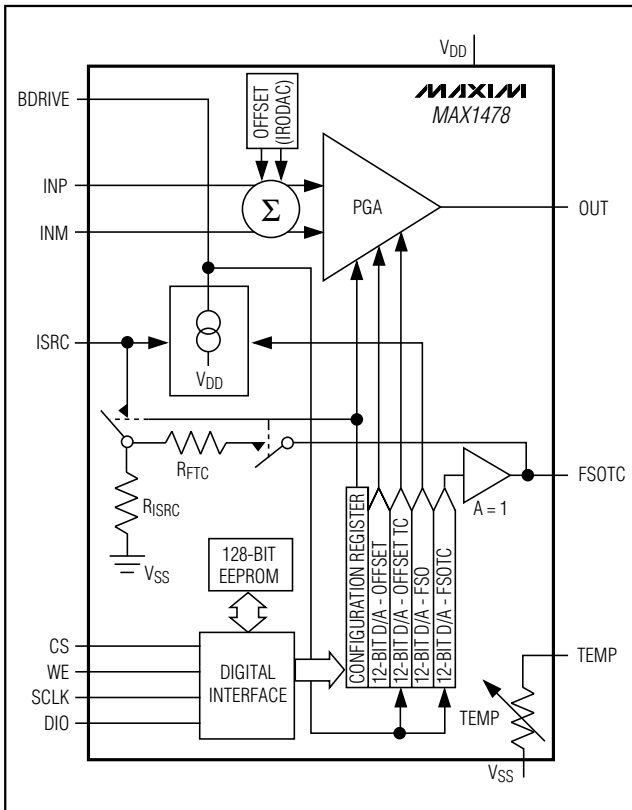

DVM, the environmental chamber, and the pressure controller through other vendors.

The 14XXDASBOARD, in conjunction with the 14XXMUXBOARD modules, allows the user to compensate up to 112 units. IEEE-488 commands select the active DUT and communicate with the MAX14XX application circuits. All system voltage measurements are multiplexed for use with a single external DVM. Each DUT interfaces to the 14XXMUXBOARD through a general-purpose transition board, which provides digital interface signals and low-noise analog inputs. The 14XXDASBOARD is required to operate the 14XXMUXBOARD. All driver software is incorporated into the 14XXDASBOARD firmware. Sensor compensation procedure is implemented using National Instruments' LabView program. Customers may have to adapt portions of the compensation procedure if they are using a pressure controller, oven, or DVM that is different from the type for which the system was designed.

The system will be available free to all customers who order MAX14XX. Minimum order quantities apply. Contact factory for details.

## Chip Information

TRANSISTOR COUNT: 7708

SUBSTRATE CONNECTED TO V<sub>SS</sub>.

## Block Diagram

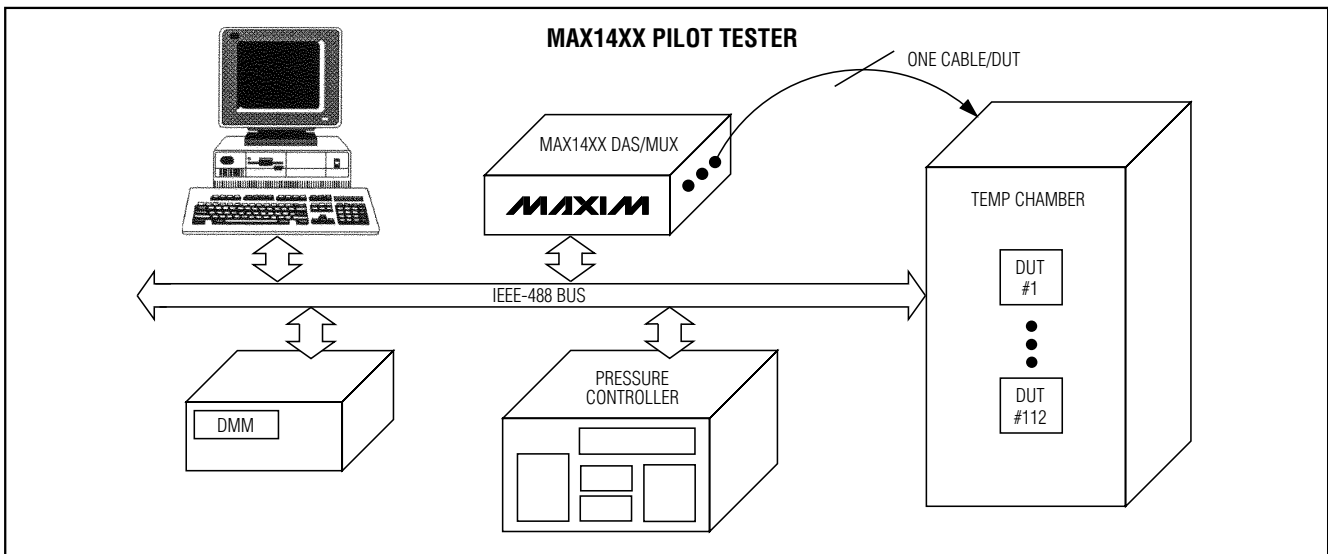

# 1% Accurate, Digitally Trimmed, Rail-to-Rail Sensor Signal Conditioner

## Package Information

**MAX1478**

DIM	INCHES		MILLIMETERS	
	MIN	MAX	MIN	MAX
A	0.068	0.078	1.73	1.99
A1	0.002	0.008	0.05	0.21
B	0.010	0.015	0.25	0.38
C	0.004	0.008	0.09	0.20
D	SEE VARIATIONS			
E	0.205	0.209	5.20	5.38
e	0.0256	BSC	0.65	BSC
H	0.301	0.311	7.65	7.90
L	0.025	0.037	0.63	0.95
$\alpha$	0°	8°	0°	8°

D	INCHES		MILLIMETERS		
	MIN	MAX	MIN	MAX	
D	0.239	0.249	6.07	6.33	14L
D	0.239	0.249	6.07	6.33	16L
D	0.278	0.289	7.07	7.33	20L
D	0.317	0.328	8.07	8.33	24L
D	0.397	0.407	10.07	10.33	28L

NOTES:  
 1. D&E DO NOT INCLUDE MOLD FLASH.  
 2. MOLD FLASH OR PROTRUSIONS NOT TO EXCEED .15mm (.006")  
 3. CONTROLLING DIMENSION: MILLIMETER

**MAXIM**  
 PROPRIETARY INFORMATION  
 TITLE: PACKAGE OUTLINE, SSOP, 5.3X.65mm  
 APPROVAL: \_\_\_\_\_ DOCUMENT CONTROL NO. 21-0056 REV A 1/1

SSOP-EPS

# **1% Accurate, Digitally Trimmed, Rail-to-Rail Sensor Signal Conditioner**

## NOTES

*Maxim cannot assume responsibility for use of any circuitry other than circuitry entirely embodied in a Maxim product. No circuit patent licenses are implied. Maxim reserves the right to change the circuitry and specifications without notice at any time.*

**20** \_\_\_\_\_ **Maxim Integrated Products, 120 San Gabriel Drive, Sunnyvale, CA 94086 408-737-7600**