



16-Bit, 135ksp/s, Single-Supply ADCs with Bipolar Analog Input Range

General Description

The MAX1178/MAX1188 16-bit, low-power, successive-approximation analog-to-digital converters (ADCs) feature automatic power-down, a factory-trimmed internal clock, and a byte-wide parallel interface. The devices operate from a single +4.75V to +5.25V analog supply and feature a separate digital supply input for direct interface with a +2.7V to +5.25V digital logic.

The MAX1188 accepts a bipolar analog input voltage range of $\pm 10V$, while the MAX1178 accepts a bipolar analog input voltage range of $\pm 5V$. All devices consume no more than 26.5mW at a sampling rate of 135ksp/s when using an external reference, and 31mW when using the internal +4.096V reference. AutoShutdown™ reduces supply current to 0.4mA at 10ksp/s.

The MAX1178/MAX1188 are ideal for high-performance, battery-powered, data-acquisition applications. Excellent AC performance (THD = -100dB) and DC accuracy (± 2 LSB INL) make the MAX1178/MAX1188 ideal for industrial process control, instrumentation, and medical applications.

The MAX1178/MAX1188 are available in a 20-pin TSSOP package and are fully specified over the -40°C to +85°C extended temperature range and the 0°C to +70°C commercial temperature range.

Applications

- Temperature Sensing and Monitoring
- Industrial Process Control
- I/O Modules
- Data-Acquisition Systems
- Precision Instrumentation

Pin Configuration and Functional Diagram appear at end of data sheet.

Features

- ◆ Byte-Wide Parallel Interface
- ◆ Analog Input Voltage Range: $\pm 10V$, $\pm 5V$
- ◆ Single +4.75V to +5.25V Analog Supply Voltage
- ◆ Interface with +2.7V to +5.25V Digital Logic
- ◆ ± 2 LSB INL
- ◆ ± 1 LSB DNL
- ◆ Low Supply Current (max)
 - 2.9mA (External Reference)
 - 3.8mA (Internal Reference)
 - 5 μA AutoShutdown Mode
- ◆ Small Footprint
- ◆ 20-Pin TSSOP Package

Ordering Information

PART	TEMP RANGE	PIN-PACKAGE	INPUT VOLTAGE RANGE (V)
MAX1178ACUP	0°C to +70°C	20 TSSOP	± 5
MAX1178BCUP	0°C to +70°C	20 TSSOP	± 5
MAX1178CCUP	0°C to +70°C	20 TSSOP	± 5
MAX1178AEUP	-40°C to +85°C	20 TSSOP	± 5
MAX1178BEUP	-40°C to +85°C	20 TSSOP	± 5
MAX1178CEUP	-40°C to +85°C	20 TSSOP	± 5

Ordering Information continued at end of data sheet.

Typical Operating Circuit

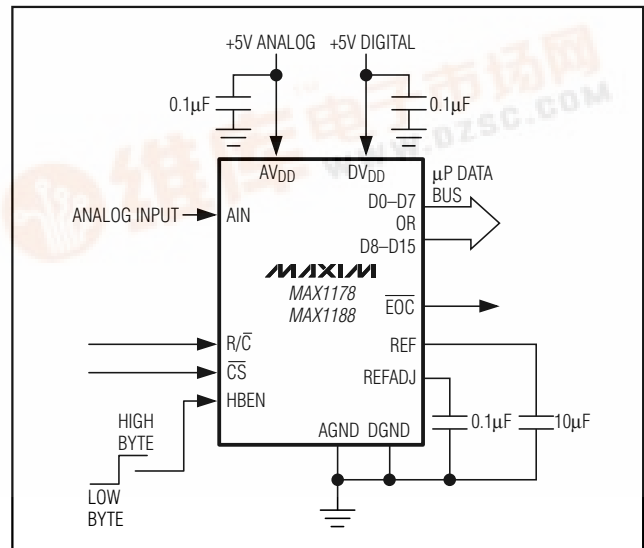

MAX1178/MAX1188

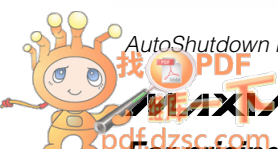

16-Bit, 135ksps, Single-Supply ADCs with Bipolar Analog Input Range

ABSOLUTE MAXIMUM RATINGS

AV _{DD} to AGND	-0.3V to +6V	Continuous Power Dissipation (T _A = +70°C)	
DV _{DD} to DGND	-0.3V to +6V	TSSOP (derate 10.9mW/°C above +70°C)	879mW
AGND to DGND	-0.3V to +0.3V	Operating Temperature Ranges	
A _{IN} to AGND	-16.5V to +16.5V	MAX11__CUP	0°C to +70°C
REF, REFADJ to AGND	-0.3V to (AV _{DD} + 0.3V)	MAX11__EUP	-40°C to +85°C
CS, R/C, HBEN to DGND	-0.3V to +6V	Storage Temperature Range	-65°C to +150°C
D ₋ , EOC to DGND	-0.3V to (DV _{DD} + 0.3V)	Junction Temperature	+150°C
Maximum Continuous Current into Any Pin	50mA	Lead Temperature (soldering, 10s)	+300°C

Stresses beyond those listed under "Absolute Maximum Ratings" may cause permanent damage to the device. These are stress ratings only, and functional operation of the device at these or any other conditions beyond those indicated in the operational sections of the specifications is not implied. Exposure to absolute maximum rating conditions for extended periods may affect device reliability.

ELECTRICAL CHARACTERISTICS

(AV_{DD} = DV_{DD} = +5V ±5%, external reference = +4.096V, C_{REF} = 10µF, C_{REFADJ} = 0.1µF, V_{REFADJ} = AV_{DD}, T_A = T_{MIN} to T_{MAX}, unless otherwise noted. Typical values are at T_A = +25°C.)

PARAMETER	SYMBOL	CONDITIONS	MIN	TYP	MAX	UNITS	
DC ACCURACY							
Resolution	RES		16			Bits	
Differential Nonlinearity	DNL	No missing codes over temperature	MAX11__A	-1	+1	LSB	
			MAX11__B	-1.0	+1.5		
			MAX11__C	-1	+2		
Integral Nonlinearity	INL	MAX11__A	-2	+2	LSB		
		MAX11__B	-2	+2			
		MAX11__C	-4	+4			
Transition Noise		RMS noise, external reference		0.6		LSB _{RMS}	
		Internal reference		0.75			
Offset Error			-10	0	+10	mV	
Gain Error				0	±0.2	%FSR	
Offset Drift				16		µV/°C	
Gain Drift				±1		ppm/°C	
AC ACCURACY (f _{IN} = 1kHz, V _{AIN} = full range, 135ksps)							
Signal-to-Noise Plus Distortion	SINAD		86	90		dB	
Signal-to-Noise Ratio	SNR		87	91		dB	
Total Harmonic Distortion	THD			-100	-92	dB	
Spurious-Free Dynamic Range	SFDR		92	103		dB	
ANALOG INPUT							
Input Range	V _{AIN}	MAX1178	-5		+5	V	
		MAX1188	-10		+10		
Input Resistance	R _{AIN}	MAX1178	Normal operation	5.3	6.9	9.2	kΩ
			Shutdown mode	3.0			
		MAX1188	Normal operation	7.8	10	13.0	
			Shutdown mode	6.0			

16-Bit, 135ksps, Single-Supply ADCs with Bipolar Analog Input Range

MAX1178/MAX1188

ELECTRICAL CHARACTERISTICS (continued)

($V_{DD} = DV_{DD} = +5V \pm 5\%$, external reference = +4.096V, $C_{REF} = 10\mu F$, $C_{REFADJ} = 0.1\mu F$, $V_{REFADJ} = AV_{DD}$, $T_A = T_{MIN}$ to T_{MAX} , unless otherwise noted. Typical values are at $T_A = +25^\circ C$.)

PARAMETER	SYMBOL	CONDITIONS	MIN	TYP	MAX	UNITS
Input Current	I_{AIN}	MAX1178, $-5V \leq V_{AIN} \leq +5V$	Normal operation	-1.8	+0.4	mA
			Shutdown mode	-1.8	+1.8	
		MAX1188, $-10V \leq V_{AIN} \leq +10V$	Normal operation	-1.8	+1.2	
			Shutdown mode	-1.8	+1.8	
Input Current Step at Power-Up	I_{PU}	MAX1178, $V_{AIN} = +5V$, shutdown mode to operating mode		1	1.4	mA
		MAX1188, $V_{AIN} = +10V$, shutdown mode to operating mode		0.5	0.7	
Input Capacitance	C_{IN}			10		pF
INTERNAL REFERENCE						
REF Output Voltage	V_{REF}		4.056	4.096	4.136	V
REF Output Tempco				± 35		ppm/ $^\circ C$
REF Short-Circuit Current	I_{REF-SC}			± 10		mA
EXTERNAL REFERENCE						
REF and REFADJ Input-Voltage Range			3.8		4.2	V
REFADJ Buffer-Disable Threshold			$AV_{DD} - 0.4$		$AV_{DD} - 0.1$	V
REF Input Current	I_{REF}	Normal mode, $f_{SAMPLE} = 135ksps$		60	100	μA
		Shutdown mode (Note 1)		± 0.1	± 10	
REFADJ Input Current	I_{REFADJ}	REFADJ = AV_{DD}		16		μA
DIGITAL INPUTS/OUTPUTS						
Output High Voltage	V_{OH}	$I_{SOURCE} = 0.5mA$, $DV_{DD} = +2.7V$ to $+5.25V$, $AV_{DD} = +5.25V$	$DV_{DD} - 0.4$			V
Output Low Voltage	V_{OL}	$I_{SINK} = 1.6mA$, $DV_{DD} = +2.7V$ to $+5.25V$, $AV_{DD} = +5.25V$			0.4	V
Input High Voltage	V_{IH}		$0.7 \times DV_{DD}$			V
Input Low Voltage	V_{IL}				$0.3 \times DV_{DD}$	V
Input Leakage Current		Digital input = DV_{DD} or 0V	-1		+1	μA
Input Hysteresis	V_{HYST}			0.2		V
Input Capacitance	C_{IN}			15		pF
Tri-State Output Leakage	I_{OZ}				± 10	μA
Tri-State Output Capacitance	C_{OZ}			15		pF

16-Bit, 135ksps, Single-Supply ADCs with Bipolar Analog Input Range

ELECTRICAL CHARACTERISTICS (continued)

($AV_{DD} = DV_{DD} = +5V \pm 5\%$, external reference = +4.096V, $C_{REF} = 10\mu F$, $C_{REFADJ} = 0.1\mu F$, $V_{REFADJ} = AV_{DD}$, $T_A = T_{MIN}$ to T_{MAX} , unless otherwise noted. Typical values are at $T_A = +25^\circ C$.)

PARAMETER	SYMBOL	CONDITIONS	MIN	TYP	MAX	UNITS
POWER SUPPLIES						
Analog Supply Voltage	AV_{DD}		4.75		5.25	V
Digital Supply Voltage	DV_{DD}		2.70		5.25	V
Analog Supply Current	I_{AVDD}	External reference, 135ksps		4	5.3	mA
		Internal reference, 135ksps		5.2	6.2	
Shutdown Supply Current	I_{SHDN}	Shutdown mode (Note 1), digital input = DV_{DD} or 0V		0.5	5	μA
		Standby mode		3.7		mA
Digital Supply Current	I_{DVDD}				0.75	mA
Power-Supply Rejection		$AV_{DD} = DV_{DD} = 4.75V$ to $5.25V$		3.5		LSB

TIMING CHARACTERISTICS (Figures 1 and 2)

($AV_{DD} = +4.75V$ to $+5.25V$, $DV_{DD} = +2.7V$ to AV_{DD} , external reference = +4.096V, $C_{REF} = 10\mu F$, $C_{REFADJ} = 0.1\mu F$, $V_{REFADJ} = AV_{DD}$, $C_{LOAD} = 20pF$, $T_A = T_{MIN}$ to T_{MAX} .)

PARAMETER	SYMBOL	CONDITIONS	MIN	TYP	MAX	UNITS
Maximum Sampling Rate	$f_{SAMPLE-MAX}$				135	ksps
Acquisition Time	t_{ACQ}		2			μs
Conversion Time	t_{CONV}				4.7	μs
\overline{CS} Pulse-Width High	t_{CSH}	(Note 2)	40			ns
\overline{CS} Pulse-Width Low (Note 2)	t_{CSL}	$DV_{DD} = 4.75V$ to $5.25V$	40			ns
		$DV_{DD} = 2.7V$ to $5.25V$	60			
R/\overline{C} to \overline{CS} Fall Setup Time	t_{DS}		0			ns
R/\overline{C} to \overline{CS} Fall Hold Time	t_{DH}	$DV_{DD} = 4.75V$ to $5.25V$	40			ns
		$DV_{DD} = 2.7V$ to $5.25V$	60			
\overline{CS} to Output Data Valid	t_{DO}	$DV_{DD} = 4.75V$ to $5.25V$			40	ns
		$DV_{DD} = 2.7V$ to $5.25V$			80	
\overline{EOC} Fall to \overline{CS} Fall	t_{DV}		0			ns
\overline{CS} Rise to \overline{EOC} Rise	t_{EOC}	$DV_{DD} = 4.75V$ to $5.25V$			40	ns
		$DV_{DD} = 2.7V$ to $5.25V$			80	
Bus Relinquish Time	t_{BR}	$DV_{DD} = 4.75V$ to $5.25V$			40	ns
		$DV_{DD} = 2.7V$ to $5.25V$			80	
HBEN Transition to Output Data Valid	t_{DO1}	$DV_{DD} = 4.75V$ to $5.25V$			40	ns
		$DV_{DD} = 2.7V$ to $5.25V$			80	

Note 1: Maximum specification is limited by automated test equipment.

Note 2: To ensure best performance, finish reading the data and wait t_{BR} before starting a new acquisition.

16-Bit, 135ksps, Single-Supply ADCs with Bipolar Analog Input Range

Typical Operating Characteristics

(Typical Operating Circuit, $AV_{DD} = DV_{DD} = +5V$, external reference = +4.096V, $C_{REF} = 10\mu F$, $C_{REFADJ} = 0.1\mu F$, $V_{REFADJ} = AV_{DD}$, $C_{LOAD} = 20pF$. Typical values are at $T_A = +25^\circ C$, unless otherwise noted.)

MAX1178/MAX1188

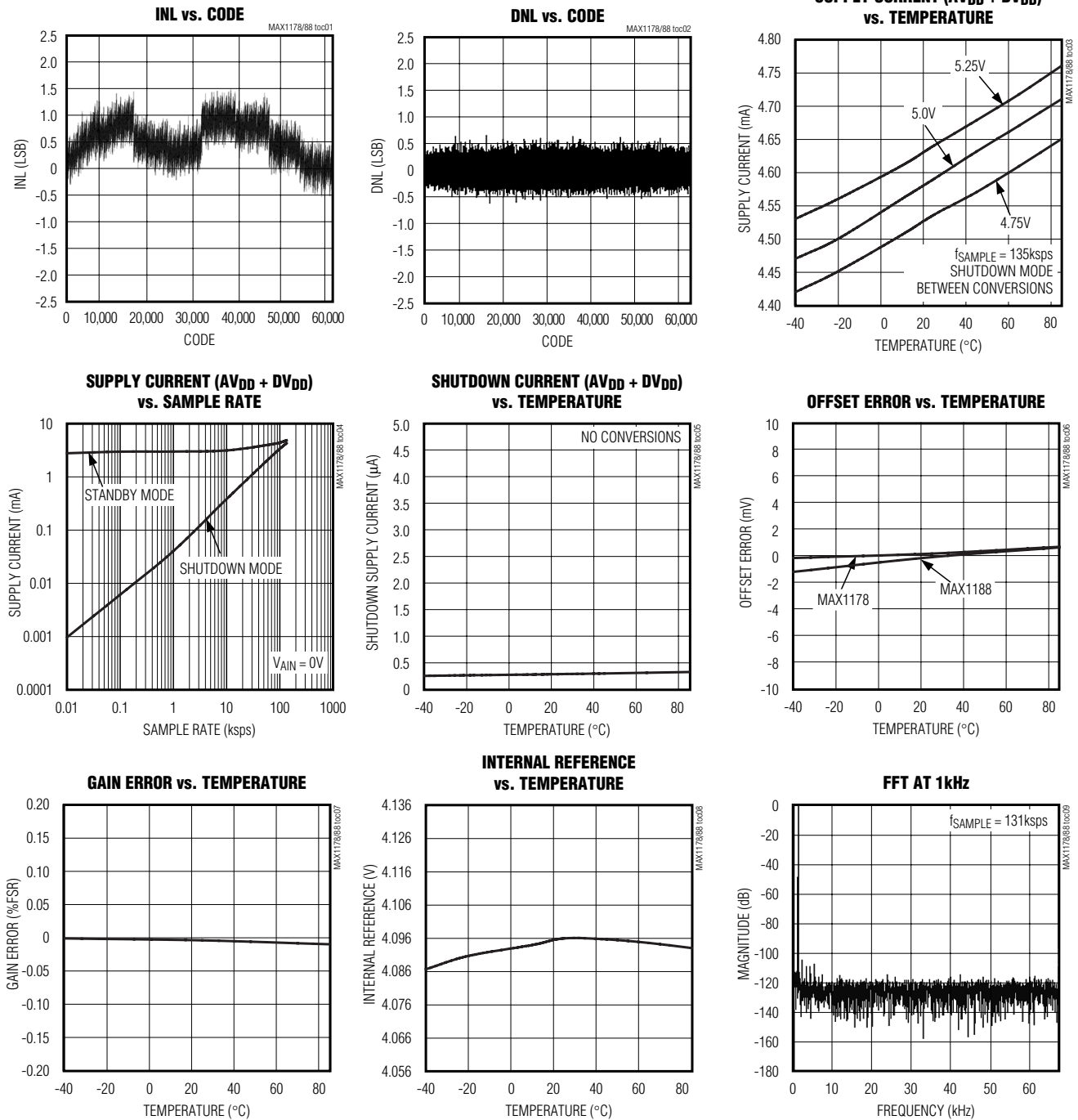

16-Bit, 135kps, Single-Supply ADCs with Bipolar Analog Input Range

Typical Operating Characteristics (continued)

(Typical Operating Circuit, $AV_{DD} = DV_{DD} = +5V$, external reference = +4.096V, $C_{REF} = 10\mu F$, $C_{REFADJ} = 0.1\mu F$, $V_{REFADJ} = AV_{DD}$, $C_{LOAD} = 20pF$. Typical values are at $T_A = +25^\circ C$, unless otherwise noted.)

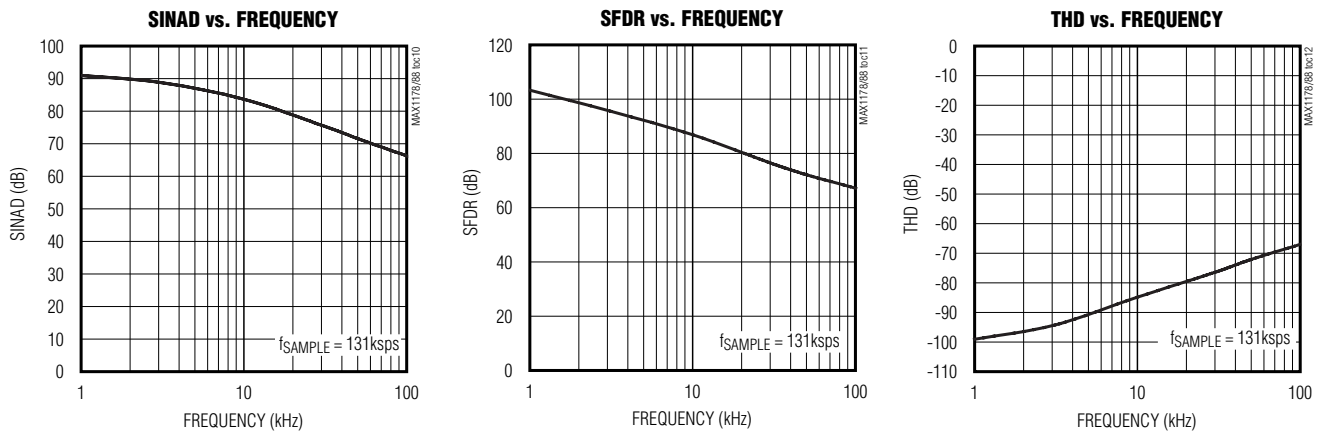

Pin Description

PIN	NAME	FUNCTION
1	D4/D12	Tri-State Digital-Data Output
2	D5/D13	Tri-State Digital-Data Output
3	D6/D14	Tri-State Digital-Data Output
4	D7/D15	Tri-State Digital-Data Output. D15 is the MSB.
5	R/\overline{C}	Read/Convert Input. Power up and put the MAX1178/MAX1188 in acquisition mode by holding R/\overline{C} low during the first falling edge of \overline{CS} . During the second falling edge of \overline{CS} , the level on R/\overline{C} determines whether the reference and reference buffer power down or remain on after conversion. Set R/\overline{C} high during the second falling edge of \overline{CS} to power down the reference and buffer, or set R/\overline{C} low to leave the reference and buffer powered up. Set R/\overline{C} high during the third falling edge of \overline{CS} to put valid data on the bus.
6	\overline{EOC}	End of Conversion. \overline{EOC} drives low when conversion is complete.
7	AV_{DD}	Analog Supply Input. Bypass with a 0.1 μF capacitor to AGND.
8	AGND	Analog Ground. Primary analog ground (star ground).
9	AIN	Analog Input
10	AGND	Analog Ground. Connect pin 10 to pin 8.
11	REFADJ	Reference Buffer Output. Bypass REFADJ with a 0.1 μF capacitor to AGND for internal reference mode. Connect REFADJ to AV_{DD} to select external reference mode.
12	REF	Reference Input/Output. Bypass REF with a 10 μF capacitor to AGND for internal reference mode. External reference input when in external reference mode.

16-Bit, 135kps, Single-Supply ADCs with Bipolar Analog Input Range

MAX1178/MAX1188

Pin Description (continued)

PIN	NAME	FUNCTION
13	HBEN	High-Byte Enable Input. Used to multiplex the 16-bit conversion result. 1: MSB available on the data bus. 0: LSB available on the data bus.
14	\overline{CS}	Convert Start. The first falling edge of \overline{CS} powers up the device and enables acquire mode when R/\overline{C} is low. The second falling edge of \overline{CS} starts conversion. The third falling edge of \overline{CS} loads the result onto the bus when R/\overline{C} is high.
15	DGND	Digital Ground
16	DV _{DD}	Digital Supply Voltage. Bypass with a 0.1 μ F capacitor to DGND.
17	D0/D8	Tri-State Digital-Data Output. D0 is the LSB.
18	D1/D9	Tri-State Digital-Data Output
19	D2/D10	Tri-State Digital-Data Output
20	D3/D11	Tri-State Digital-Data Output

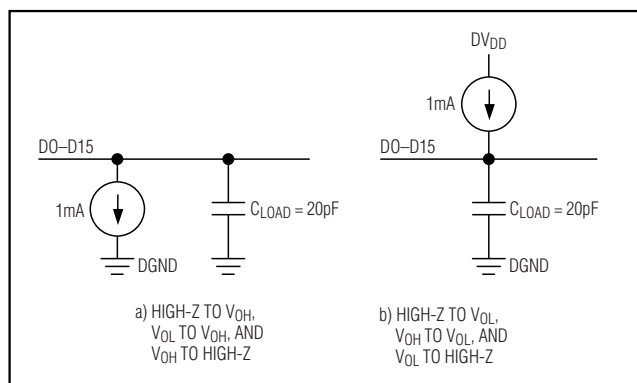

Figure 1. Load Circuits

Detailed Description

Converter Operation

The MAX1178/MAX1188 use a successive-approximation (SAR) conversion technique with an inherent track-and-hold (T/H) stage to convert an analog input into a 16-bit digital output. Parallel outputs provide a high-speed interface to microprocessors (μ Ps). The *Functional Diagram* shows a simplified internal architecture of the MAX1178/MAX1188. Figure 3 shows a typical operating circuit for the MAX1178/MAX1188.

Analog Input Input Scaler

The MAX1178/MAX1188 have an input scaler, which allows conversion of true bipolar input voltages and input voltages greater than the power supply, while operating from a single +5V analog supply. The input scaler attenuates and shifts the analog input to match the input range of the internal digital-to-analog converter (DAC). The MAX1178 input voltage range is $\pm 5V$, while the MAX1188 input voltage range is $\pm 10V$. Figure 4 shows the equivalent input circuit of the MAX1178/MAX1188. This circuit limits the current going into or out of AIN to less than 1.8mA.

Track and Hold (T/H)

In track mode, the internal hold capacitor acquires the analog signal (Figure 4). In hold mode, the T/H switches open and the capacitive DAC samples the analog input. During the acquisition, the analog input (AIN) charges capacitor C_{HOLD}. The acquisition ends on the second falling edge of \overline{CS} . At this instant, the T/H switches open. The retained charge on C_{HOLD} represents a sample of the input. In hold mode, the capacitive DAC adjusts during the remainder of the conversion time to restore node T/H OUT to zero within the limits of 16-bit resolution. Force \overline{CS} low to put valid data on the bus after conversion is complete.

16-Bit, 135kps, Single-Supply ADCs with Bipolar Analog Input Range

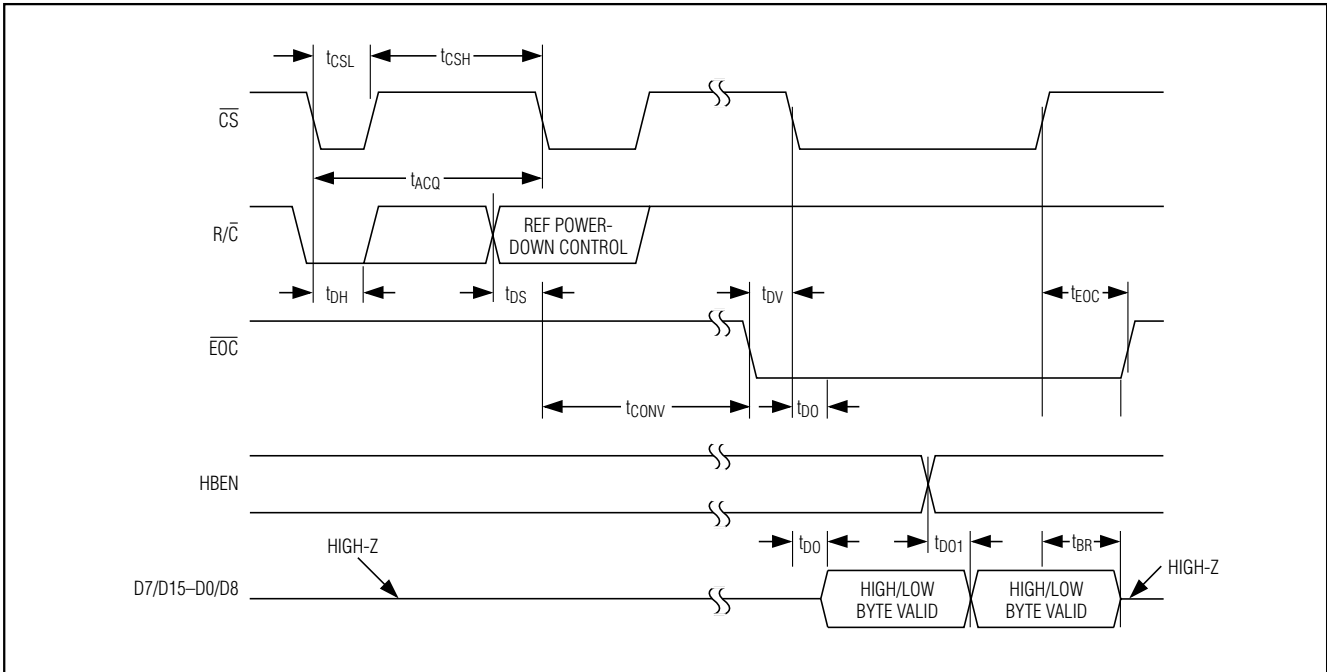

Figure 2. MAX1178/MAX1188 Timing Diagram

Power-Down Modes

Select standby mode or shutdown mode with the R/\overline{C} bit during the second falling edge of \overline{CS} (see the *Selecting Standby or Shutdown Mode* section). The MAX1178/MAX1188 automatically enter either standby mode (reference and buffer on) or shutdown (reference and buffer off) after each conversion, depending on the status of R/\overline{C} during the second falling edge of \overline{CS} .

Internal Clock

The MAX1178/MAX1188 generate an internal conversion clock to free the μP from the burden of running the SAR conversion clock. Total conversion time (t_{CONV}) after entering hold mode (second falling edge of \overline{CS}) to end-of-conversion (\overline{EOC}) falling is 4.7 μs (max).

Applications Information

Starting a Conversion

\overline{CS} and R/\overline{C} control acquisition and conversion in the MAX1178/MAX1188 (Figure 2). The first falling edge of \overline{CS} powers up the device and puts it in acquire mode if R/\overline{C} is low. The convert start is ignored if R/\overline{C} is high. The MAX1178/MAX1188 need at least 12ms for the internal reference to wake up and settle before starting the conversion ($C_{REFADJ} = 0.1\mu F$, $C_{REF} = 10\mu F$), if powering up from shutdown.

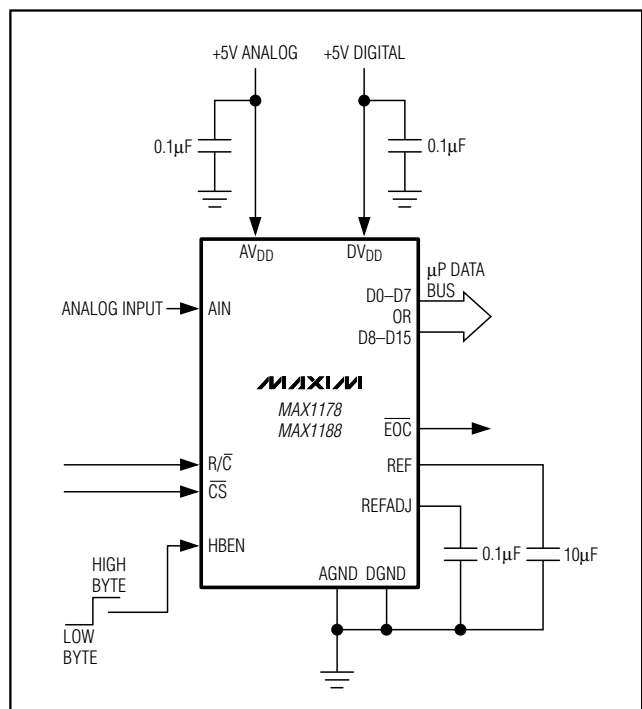

Figure 3. Typical Operating Circuit for the MAX1178/MAX1188

16-Bit, 135kps, Single-Supply ADCs with Bipolar Analog Input Range

Selecting Standby or Shutdown Mode

The MAX1178/MAX1188 have a selectable standby or low-power shutdown mode. In standby mode, the ADC's internal reference and reference buffer do not power down between conversions, eliminating the need to wait for the reference to power up before performing the next conversion. Shutdown mode powers down the reference and reference buffer after completing a conversion. The reference and reference buffer require a minimum of 12ms to power up and settle from shutdown ($C_{REFADJ} = 0.1\mu\text{F}$, $C_{REF} = 10\mu\text{F}$).

The state of R/\overline{C} at the second falling edge of \overline{CS} selects which power-down mode the MAX1178/MAX1188 enter upon conversion completion. Holding R/\overline{C} low causes the MAX1178/MAX1188 to enter standby mode. The reference and buffer are left on after the conversion completes. R/\overline{C} high causes the MAX1178/MAX1188 to enter shutdown mode and power-down the reference and buffer after conversion (Figures 5 and 6). Set the voltage at R/\overline{C} high during the second falling edge of \overline{CS} to realize the lowest current operation.

Standby Mode

While in standby mode, the supply current is less than 3.7mA (typ). The next falling edge of \overline{CS} with R/\overline{C} low causes the MAX1178/MAX1188 to exit standby mode and begin acquisition. The reference and reference buffer remain active to allow quick turn-on time.

Shutdown Mode

In shutdown mode, the reference and reference buffer are shut down between conversions. Shutdown mode reduces supply current to 0.5 μA (typ) immediately after the conversion. The next falling edge of \overline{CS} with R/\overline{C} low causes the reference and buffer to wake up and enter acquisition mode. To achieve 16-bit accuracy, allow 12ms for the internal reference to wake up ($C_{REFADJ} = 0.1\mu\text{F}$, $C_{REF} = 10\mu\text{F}$).

Internal and External Reference

Internal Reference

The internal reference of the MAX1178/MAX1188 is internally buffered to provide +4.096V output at REF. Bypass REF to AGND and REFADJ to AGND with 10 μF and 0.1 μF , respectively. Sink or source current at REFADJ to make fine adjustments to the internal reference. The input impedance of REFADJ is nominally 5k Ω . Use the circuit in Figure 7 to adjust the internal reference to $\pm 1.5\%$.

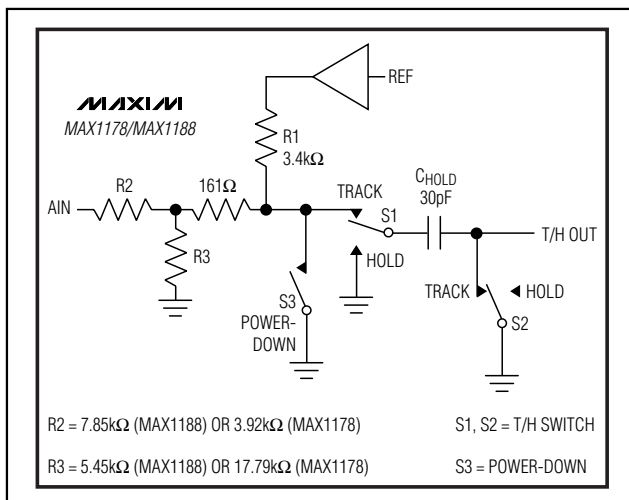

Figure 4. Equivalent Input Circuit

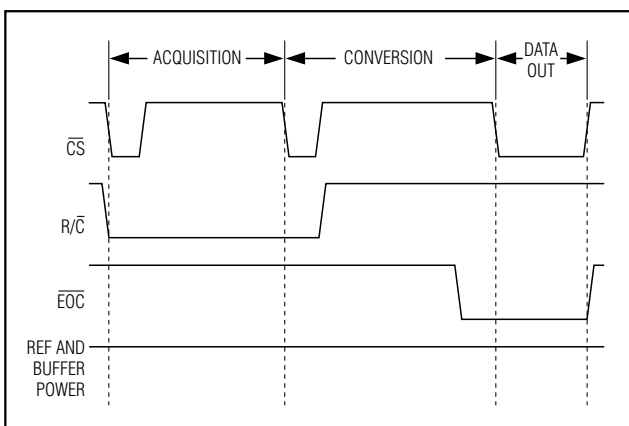

Figure 5. Selecting Standby Mode

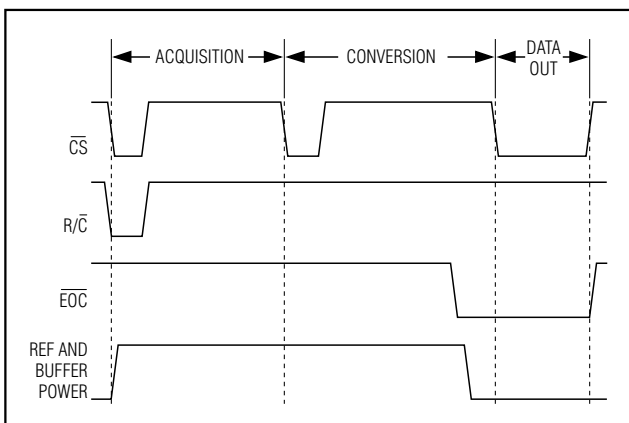

Figure 6. Selecting Shutdown Mode

MAX1178/MAX1188

16-Bit, 135kps, Single-Supply ADCs with Bipolar Analog Input Range

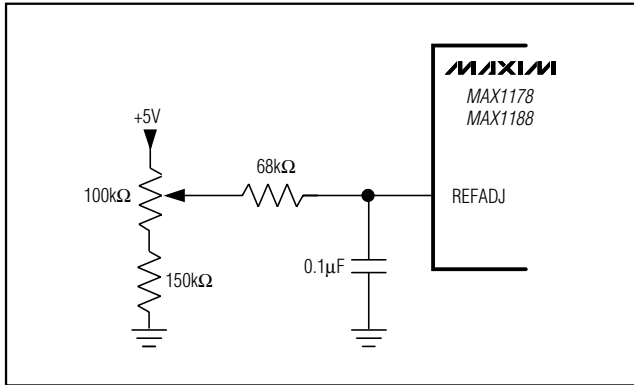

Figure 7. MAX1178/MAX1188 Reference-Adjust Circuit

External Reference

An external reference can be placed at either the input (REFADJ) or the output (REF) of the MAX1178/MAX1188s' internal buffer amplifier. Using the buffered REFADJ input makes buffering the external reference unnecessary. The input impedance of REFADJ is typically 5kΩ. The internal buffer output must be bypassed at REF with a 10μF capacitor.

Connect REFADJ to AVDD to disable the internal buffer. Directly drive REF using an external 3.8V to 4.2V reference. During conversion, the external reference must be able to drive 100μA of DC load current and have an output impedance of 10Ω or less.

For optimal performance, buffer the reference through an op amp and bypass REF with a 10μF capacitor. Consider the MAX1178/MAX1188s' equivalent input noise (0.6 LSB) when choosing a reference.

Reading the Conversion Result

\overline{EOC} is provided to flag the μP when a conversion is complete. The falling edge of \overline{EOC} signals that the data is valid and ready to be output to the bus. D0–D15 are the parallel outputs of the MAX1178/MAX1188. These tri-state outputs allow for direct connection to a microcontroller I/O bus. The outputs remain high impedance during acquisition and conversion. Data is loaded onto the output bus with the third falling edge of \overline{CS} with R/C high (after t_{DO}). Bringing \overline{CS} high forces the output bus back to high impedance. The MAX1178/MAX1188 then wait for the next falling edge of \overline{CS} to start the next conversion cycle (Figure 2).

HBEN toggles the output between the high/low byte. The low byte is loaded onto the output bus when HBEN is low, and the high byte is on the bus when HBEN is high.

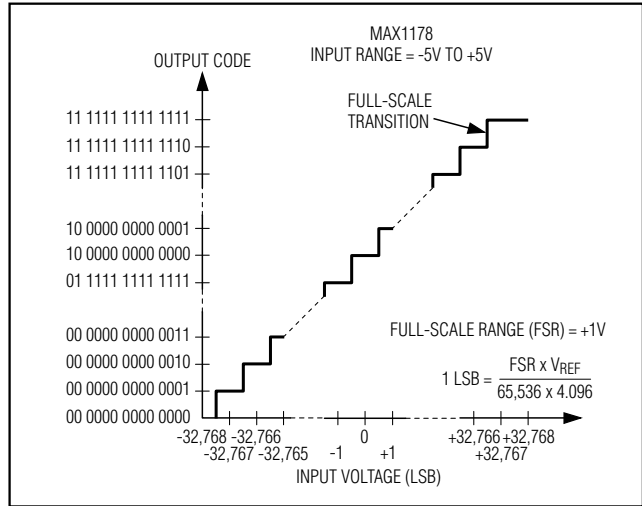

Figure 8. MAX1178 Transfer Function

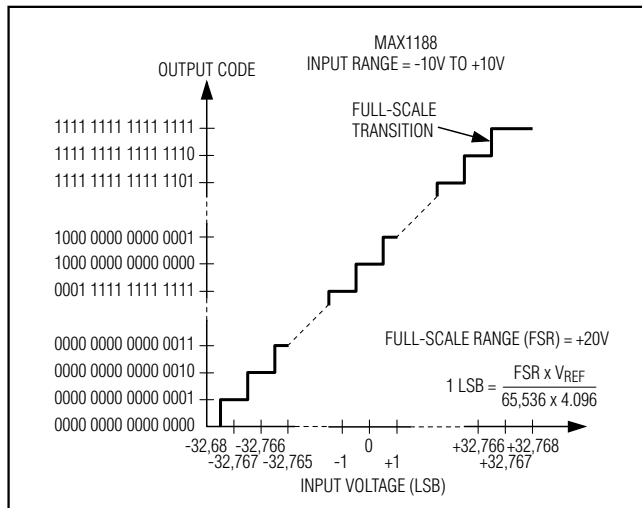

Figure 9. MAX1188 Transfer Function

Transfer Function

Figures 8 and 9 show the MAX1178/MAX1188 output transfer functions. The MAX1178 and MAX1188 outputs are coded in offset binary.

Input Buffer

Most applications require an input buffer amplifier to achieve 16-bit accuracy and prevent loading the source. When the input signal is multiplexed, switch the channels immediately after acquisition, rather than near the end of, or after, a conversion. This allows more time for the input buffer amplifier to respond to a large step

16-Bit, 135kps, Single-Supply ADCs with Bipolar Analog Input Range

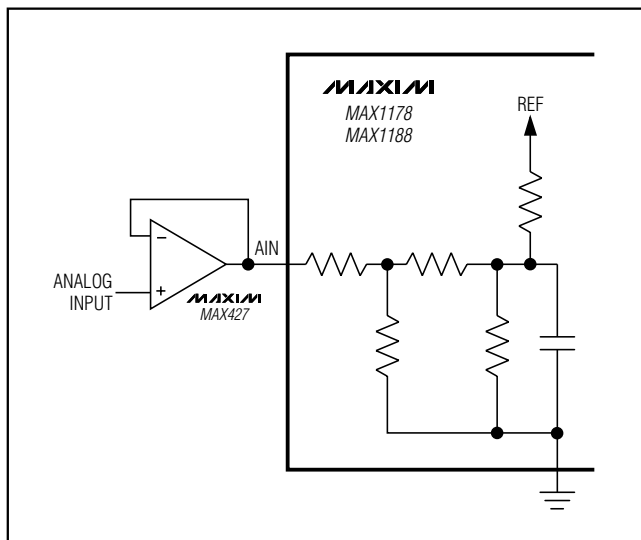

Figure 10. MAX1178/MAX1188 Fast-Settling Input Buffer

change in input signal. The input amplifier must have a high enough slew rate to complete the required output voltage change before the beginning of the acquisition time. Figure 10 shows an example of this circuit using the MAX427.

Figures 11 and 12 show how the MAX1178/MAX1188 analog input current varies depending on whether the chip is operating or powered down. The part is fully powered down between conversions if the voltage at $\overline{R/C}$ is set high during the second falling edge of \overline{CS} . The input current abruptly steps to the powered-up value at the start of acquisition. This step in the input current can disrupt the ADC input, depending on the driving circuit's output impedance at high frequencies. If the driving circuit cannot fully settle by the end of acquisition, the accuracy of the system can be compromised. To avoid this situation, increase the acquisition time, use a driving circuit that can settle within t_{ACQ} , or leave the MAX1178/MAX1188 powered up by setting the voltage at $\overline{R/C}$ low during the second falling edge of \overline{CS} .

Layout, Grounding, and Bypassing

For best performance, use printed circuit boards. Do not run analog and digital lines parallel to each other, and do not lay out digital signal paths underneath the ADC package. Use separate analog and digital ground planes with only one point connecting the two ground systems (analog and digital) as close to the device as possible.

Route digital signals far away from sensitive analog and reference inputs. If digital lines must cross analog lines,

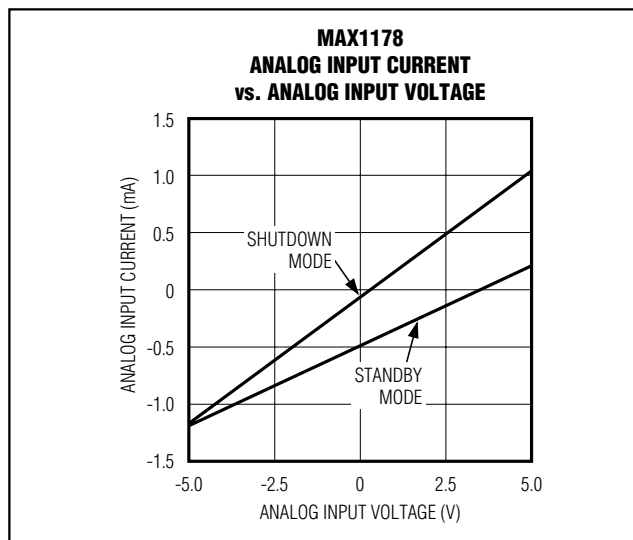

Figure 11. MAX1178 Analog Input Current

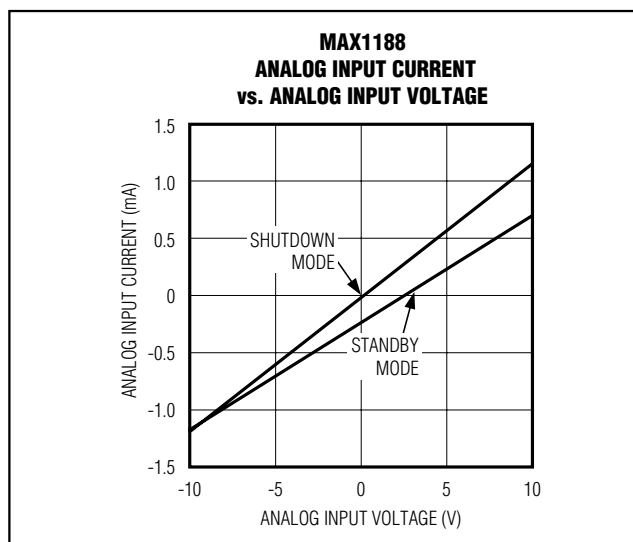

Figure 12. MAX1188 Analog Input Current

do so at right angles to minimize coupling digital noise onto the analog lines. If the analog and digital sections share the same supply, isolate the digital and analog supply by connecting them with a low-value (10Ω) resistor or ferrite bead.

The ADC is sensitive to high-frequency noise on the AV_{DD} supply. Bypass AV_{DD} to $AGND$ with a $0.1\mu F$ capacitor in parallel with a $1\mu F$ to $10\mu F$ low-ESR capacitor with the smallest capacitor closest to the device. Keep capacitor leads short to minimize stray inductance.

16-Bit, 135ksps, Single-Supply ADCs with Bipolar Analog Input Range

Definitions

Integral Nonlinearity

Integral nonlinearity (INL) is the deviation of the values on an actual transfer function from a straight line. This straight line can be either a best-straight-line fit or a line drawn between the end points of the transfer function, once offset and gain errors have been nullified. The static linearity parameters for the MAX1178/MAX1188 are measured using the end-point method.

Differential Nonlinearity

Differential nonlinearity (DNL) is the difference between an actual step width and the ideal value of 1 LSB. A DNL error specification of 1 LSB guarantees no missing codes and a monotonic transfer function.

Signal-to-Noise Ratio

For a waveform perfectly reconstructed from digital samples, signal-to-noise ratio (SNR) is the ratio of the full-scale analog input (RMS value) to the RMS quantization error (residual error). The ideal, theoretical minimum analog-to-digital noise is caused by quantization noise error only and results directly from the ADC's resolution (N bits):

$$\text{SNR} = (6.02 \times N + 1.76)\text{dB}$$

where N = 16 bits.

In reality, there are other noise sources besides quantization noise: thermal noise, reference noise, clock jitter, etc. The SNR is computed by taking the ratio of the RMS signal to the RMS noise, which includes all spectral components minus the fundamental, the first five harmonics, and the DC offset.

Signal-to-Noise Plus Distortion

Signal-to-noise plus distortion (SINAD) is the ratio of the fundamental input frequency's RMS amplitude to the RMS equivalent of all the other ADC output signals:

$$\text{SINAD(dB)} = 20 \times \log \left[\frac{\text{Signal}_{\text{RMS}}}{(\text{Noise} + \text{Distortion})_{\text{RMS}}} \right]$$

Effective Number of Bits

Effective number of bits (ENOB) indicates the global accuracy of an ADC at a specific input frequency and sampling rate. An ideal ADC error consists of quantization noise only. With an input range equal to the full-scale range of the ADC, calculate the ENOB as follows:

$$\text{ENOB} = \frac{\text{SINAD} - 1.76}{6.02}$$

Total Harmonic Distortion

Total harmonic distortion (THD) is the ratio of the RMS sum of the first five harmonics of the input signal to the fundamental itself. This is expressed as:

$$\text{THD} = 20 \times \log \left[\frac{\sqrt{V_2^2 + V_3^2 + V_4^2 + V_5^2}}{V_1} \right]$$

where V₁ is the fundamental amplitude and V₂ through V₅ are the 2nd- through 5th-order harmonics.

Spurious-Free Dynamic Range

Spurious-free dynamic range (SFDR) is the ratio of the RMS amplitude of the fundamental (maximum signal component) to the RMS value of the next-largest frequency component.

16-Bit, 135ksps, Single-Supply ADCs with Bipolar Analog Input Range

Functional Diagram

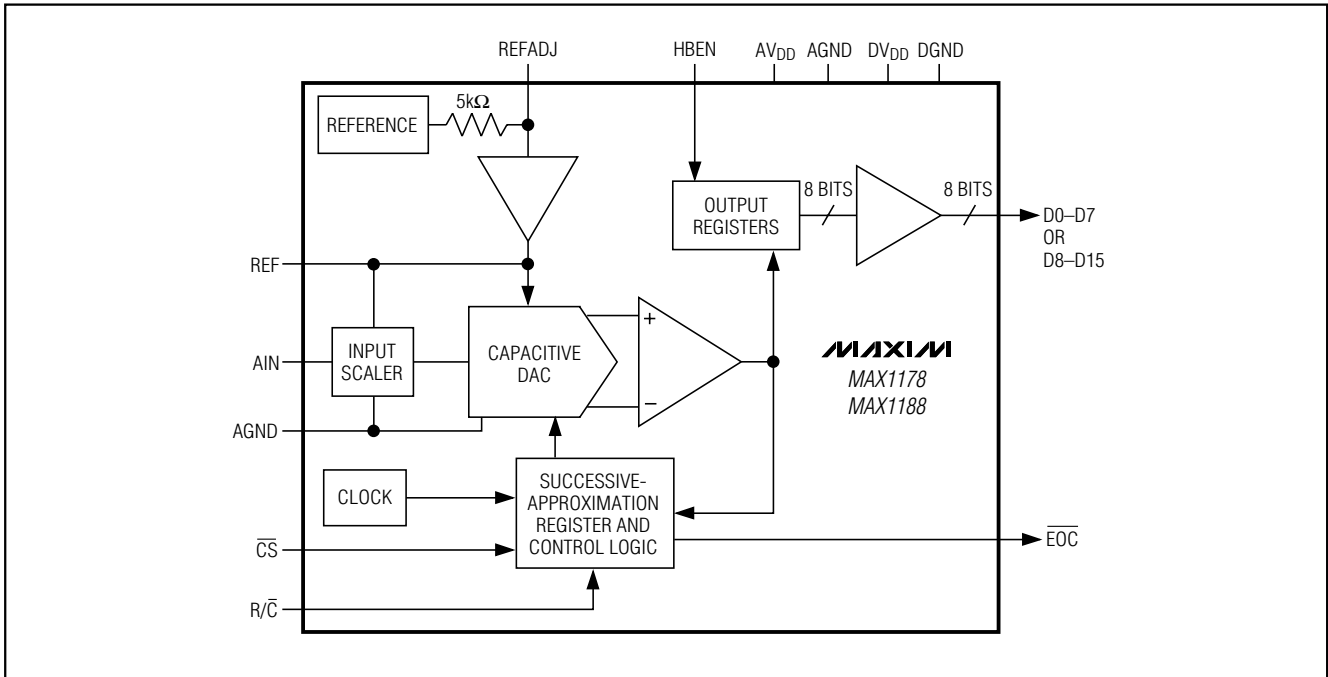

MAX1178/MAX1188

Pin Configuration

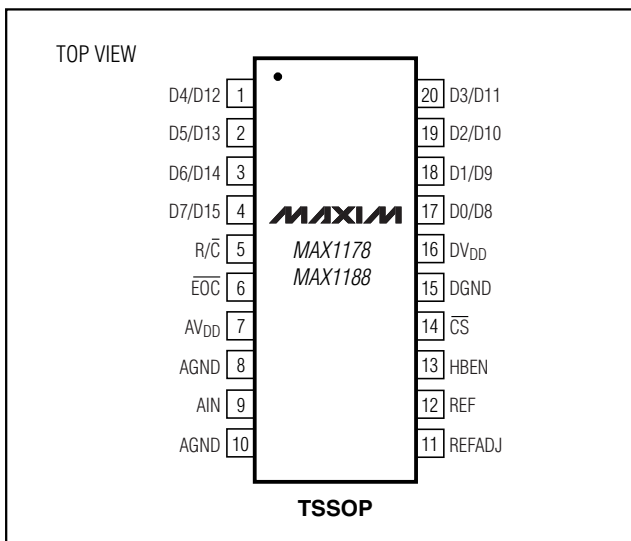

Ordering Information (continued)

PART	TEMP RANGE	PIN-PACKAGE	INPUT VOLTAGE RANGE (V)
MAX1188ACUP	0°C to +70°C	20 TSSOP	±10
MAX1188BCUP	0°C to +70°C	20 TSSOP	±10
MAX1188CCUP	0°C to +70°C	20 TSSOP	±10
MAX1188AEUP	-40°C to +85°C	20 TSSOP	±10
MAX1188BEUP	-40°C to +85°C	20 TSSOP	±10
MAX1188CEUP	-40°C to +85°C	20 TSSOP	±10

Chip Information

TRANSISTOR COUNT: 15,383
PROCESS: BiCMOS

16-Bit, 135ksp/s, Single-Supply ADCs with Bipolar Analog Input Range

Package Information

(The package drawing(s) in this data sheet may not reflect the most current specifications. For the latest package outline information, go to www.maxim-ic.com/packages.)

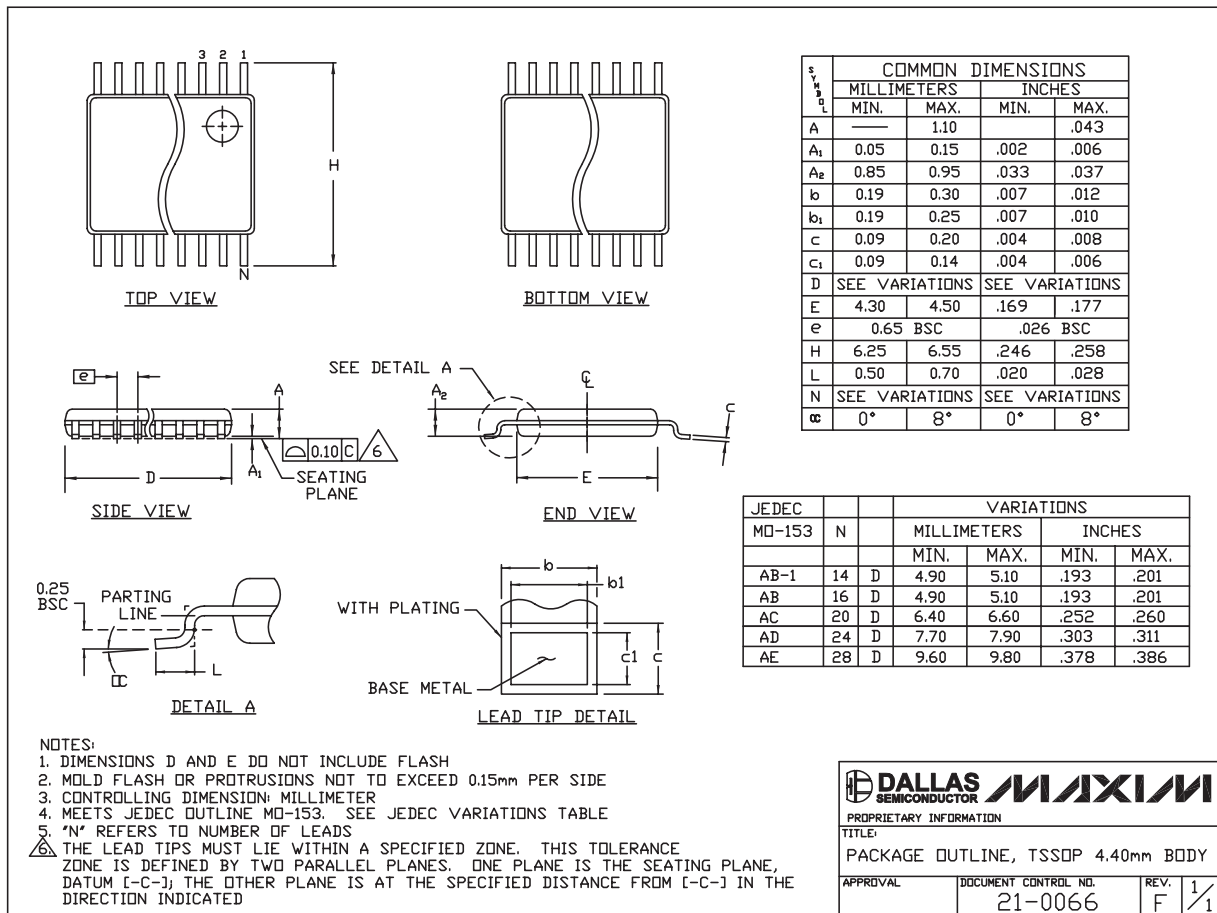

TSSOP4.40mm.EPS

DALLAS SEMICONDUCTOR **MAXIM**

PROPRIETARY INFORMATION

TITLE:
PACKAGE OUTLINE, TSSOP 4.40mm BODY

APPROVAL	DOCUMENT CONTROL NO. 21-0066	REV. F	1/1
----------	---------------------------------	-----------	-----

Maxim cannot assume responsibility for use of any circuitry other than circuitry entirely embodied in a Maxim product. No circuit patent licenses are implied. Maxim reserves the right to change the circuitry and specifications without notice at any time.