



# CY2318ANZ

## 18 Output, 3.3V SDRAM Buffer for Desktop PCs with 4 DIMMs

### Features

- One input to 18 output buffer/driver
- Supports up to four SDRAM DIMMs
- Two additional outputs for feedback
- Serial interface for individual output control
- 150ps typical output-output skew
- Up to 100 MHz operation
- Dedicated OE pin for testing
- Space-saving 48-pin SSOP package
- 3.3V operation

### Functional Description

The CY2318ANZ is a 3.3V buffer designed to distribute high-speed clocks in PC applications. The part has 18 outputs, 16 of which can be used to drive up to four SDRAM DIMMs, and the remaining can be used for external feedback to a PLL. The device operates at 3.3V and outputs can run up to 100 MHz, thus making it compatible with Pentium II® processors. The CY2318ANZ can be used in conjunction with the CY2280, CY2281, CY2282 or similar clock synthesizer for a complete Pentium II motherboard solution.

The CY2318ANZ also includes a serial interface which can enable or disable each output clock. On power-up, all output clocks are enabled (internal pull up). A separate Output Enable pin facilitates testing on ATE.

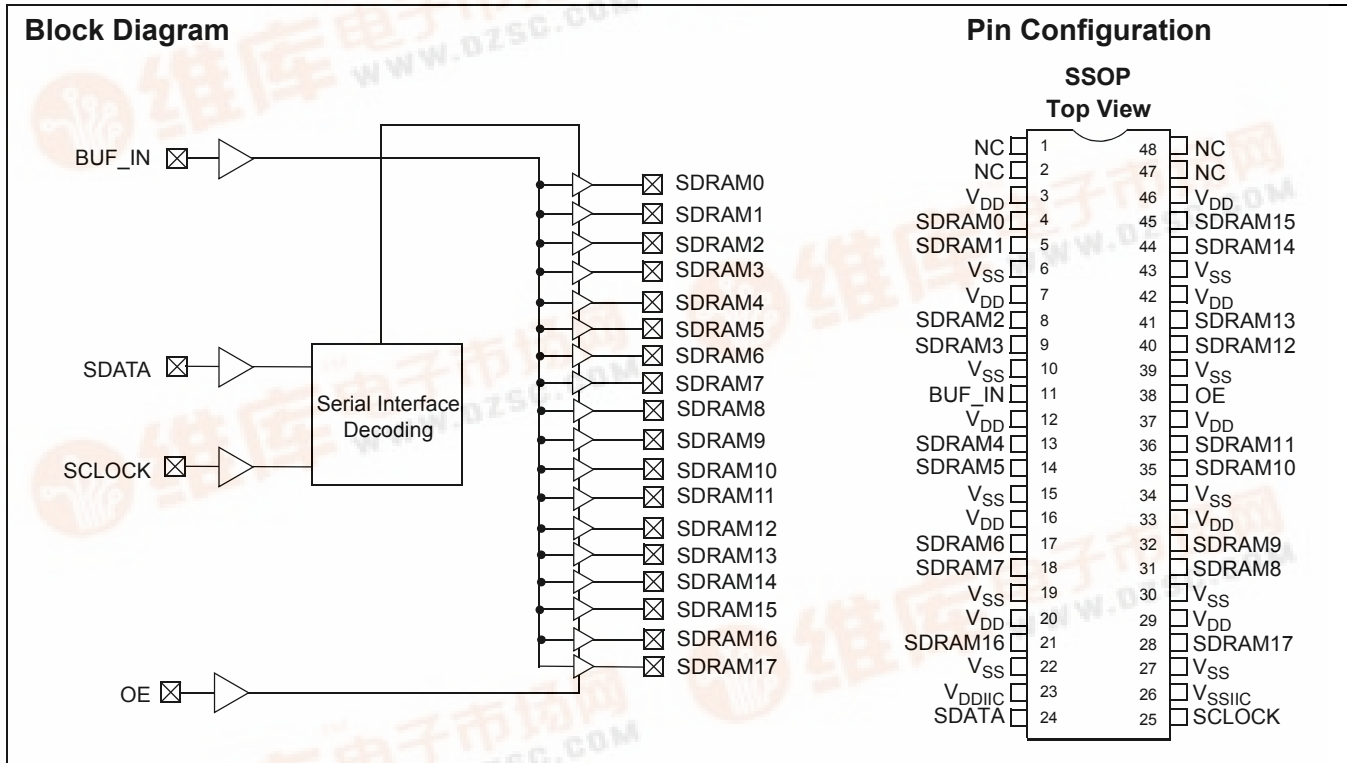

**Pin Summary**

Name	Pins	Description
V <sub>DD</sub>	3, 7, 12, 16, 20, 29, 33, 37, 42, 46	3.3V Digital voltage supply
V <sub>SS</sub>	6, 10, 15, 19, 22, 27, 30, 34, 39, 43	Ground
V <sub>DDIIC</sub>	23	Serial interface voltage supply
V <sub>SSIIC</sub>	26	Ground for serial interface
BUF_IN	11	Input clock (5V Tolerant)
OE	38	Output Enable (active HIGH), Three-state outputs when low <sup>[1]</sup>
SDATA	24	Serial data input <sup>[1]</sup>
SCLK	25	Serial clock input <sup>[1]</sup>
SDRAM [0–3]	4, 5, 8, 9	SDRAM byte 0 clock outputs
SDRAM [4–7]	13, 14, 17, 18	SDRAM byte 1 clock outputs
SDRAM [8–11]	31, 32, 35, 36	SDRAM byte 2 clock outputs
SDRAM [12–15]	40, 41, 44, 45	SDRAM byte 3 clock outputs
SDRAM [16–17]	21, 28	SDRAM clock outputs usable for feedback
N/C	1, 2, 47, 48	Reserved for future modifications, do not connect in system

**Note:**

1. Internal pull-up resistor to V<sub>DD</sub> (value > 100 kohms)

**Device Functionality**

OE	SDRAM [0–17]
0	Hi-Z
1	1 x BUF_IN

**Serial Configuration Map**

- The Serial bits will be read by the clock driver in the following order:
  - Byte 0 - Bits 7, 6, 5, 4, 3, 2, 1, 0
  - Byte 1 - Bits 7, 6, 5, 4, 3, 2, 1, 0
  - ...
  - Byte N - Bits 7, 6, 5, 4, 3, 2, 1, 0
- Reserved and unused bits should be programmed to "0".
- Serial interface address for the CY2318ANZ is:

A6	A5	A4	A3	A2	A1	A0	R/W
1	1	0	1	0	0	1	----

**Byte 0:SDRAM Active/Inactive Register  
(1 = Active, 0 = Inactive), Default = Active**

Bit	Pin #	Description
Bit 7	18	SDRAM7 (Active/Inactive)
Bit 6	17	SDRAM6 (Active/Inactive)
Bit 5	14	SDRAM5 (Active/Inactive)
Bit 4	13	SDRAM4 (Active/Inactive)
Bit 3	9	SDRAM3 (Active/Inactive)
Bit 2	8	SDRAM2 (Active/Inactive)
Bit 1	5	SDRAM1 (Active/Inactive)
Bit 0	4	SDRAM0 (Active/Inactive)

**Byte 1: SDRAM Active/Inactive Register  
(1 = Active, 0 = Inactive), Default = Active**

Bit	Pin #	Description
Bit 7	45	SDRAM15 (Active/Inactive)
Bit 6	44	SDRAM14 (Active/Inactive)
Bit 5	41	SDRAM13 (Active/Inactive)
Bit 4	40	SDRAM12 (Active/Inactive)
Bit 3	36	SDRAM11 (Active/Inactive)
Bit 2	35	SDRAM10 (Active/Inactive)
Bit 1	32	SDRAM9 (Active/Inactive)
Bit 0	31	SDRAM8 (Active/Inactive)

**Byte 2: SDRAM Active/Inactive Register  
(1 = Active, 0 = Inactive), Default = Active**

Bit	Pin #	Description
Bit 7	28	SDRAM17 (Active/Inactive)
Bit 6	21	SDRAM16 (Active/Inactive)
Bit 5	--	Reserved, drive to 0
Bit 4	--	Reserved, drive to 0
Bit 3	--	Reserved, drive to 0
Bit 2	--	Reserved, drive to 0
Bit 1	--	Reserved, drive to 0
Bit 0	--	Reserved, drive to 0



**Maximum Ratings**

Supply Voltage to Ground Potential .....-0.5 to +7.0V  
 DC Input Voltage (except BUF\_IN) ..... -0.5V to  $V_{DD} + 0.5$   
 DC Input Voltage (BUF\_IN)..... -0.5V to 7.0V

Storage Temperature ..... -65°C to +150°C  
 Junction Temperature ..... +150°C  
 Static Discharge Voltage..... >2000V  
 (per MIL-STD-883, Method 3015)

**Operating Conditions**

Parameter	Description	Min.	Max.	Unit
$V_{DD}, V_{DDIIC}$	Supply Voltage	3.135	3.465	V
$T_A$	Operating Temperature (Ambient Temperature)	0	70	°C
$C_L$	Load Capacitance	20	30	pF
$C_{IN}$	Input Capacitance		7	pF
$t_{PU}$	Power-up time for all $V_{DD}$ s to reach minimum specified voltage (power ramps must be monotonic)	0.05	50	ms

**Electrical Characteristics** Over the Operating Range

Parameter	Description	Test Conditions	Min.	Max.	Unit
$V_{IL}$	Input LOW Voltage <sup>[2]</sup>	For all pins except serial interface pins		0.8	V
$V_{ILiic}$	Input LOW Voltage	For serial pins only		0.7	V
$V_{IH}$	Input HIGH Voltage <sup>[2]</sup>		2.0		V
$I_{IL}$	Input LOW Current (BUF_IN input)	$V_{IN} = 0V$	-10	10	μA
$I_{IL}$	Input LOW Current (Except BUF_IN Pin)	$V_{IN} = 0V$		100	μA
$I_{IH}$	Input HIGH Current	$V_{IN} = V_{DD}$	-10	10	μA
$V_{OL}$	Output LOW Voltage <sup>[3]</sup>	$I_{OL} = 25\text{ mA}$		0.4	V
$V_{OH}$	Output HIGH Voltage <sup>[3]</sup>	$I_{OH} = -36\text{ mA}$	2.4		V
$I_{DD}$	Supply Current <sup>[3]</sup>	Unloaded outputs, 100 MHz		200	mA
$I_{DD}$	Supply Current	Loaded outputs, 100 MHz		360	mA
$I_{DD}$	Supply Current <sup>[3]</sup>	Unloaded outputs, 66.67 MHz		150	mA
$I_{DD}$	Supply Current	Loaded outputs, 66.67 MHz		230	mA
$I_{DDs}$	Supply Current	BUF_IN = $V_{DD}$ or $V_{SS}$ , all other inputs at $V_{DD}$		500	μA

**Notes:**

2. BUF\_IN input has a threshold voltage of  $V_{DD}/2$ .
3. Parameter is guaranteed by design and characterization. Not 100% tested in production.

**Switching Characteristics<sup>[4]</sup>**

Parameter	Name	Test Conditions	Min.	Typ.	Max.	Unit
	Maximum Operating Frequency				100	MHz
	Duty Cycle <sup>[3, 5]</sup> = $t_2 \div t_1$	Measured at 1.5V	45.0	50.0	55.0	%
$t_3$	Rising Edge Rate <sup>[3]</sup>	Measured between 0.4V and 2.4V	0.9	1.5	4.0	V/ns
$t_4$	Falling Edge Rate <sup>[3]</sup>	Measured between 2.4V and 0.4V	0.9	1.5	4.0	V/ns
$t_5$	Output to Output Skew <sup>[3]</sup>	All outputs equally loaded		150	250	ps
$t_6$	SDRAM Buffer LH Prop. Delay <sup>[3]</sup>	Input edge greater than 1 V/ns	1.0	3.5	5.0	ns
$t_7$	SDRAM Buffer HL Prop. Delay <sup>[3]</sup>	Input edge greater than 1 V/ns	1.0	3.5	5.0	ns
$t_8$	SDRAM Buffer Enable Delay <sup>[3]</sup>	Input edge greater than 1 V/ns	1.0	5	12	ns
$t_9$	SDRAM Buffer Disable Delay <sup>[3]</sup>	Input edge greater than 1 V/ns	1.0	20	30	ns

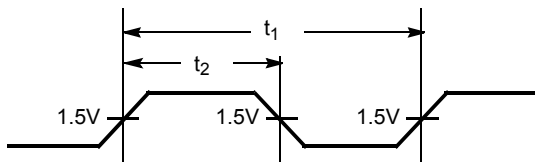
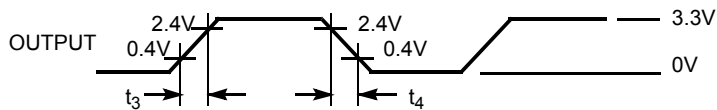
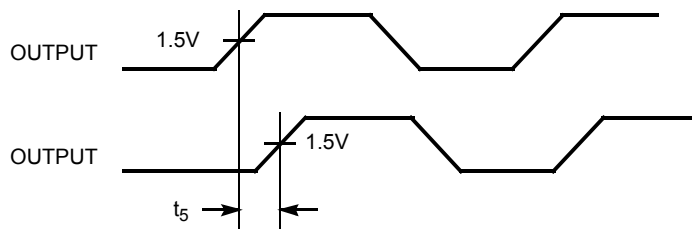
**Switching Waveforms**
**Duty Cycle Timing**

**All Outputs Rise/Fall Time**

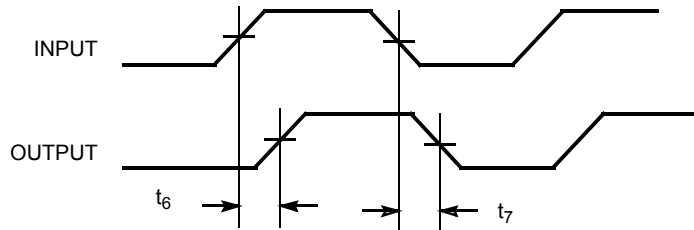
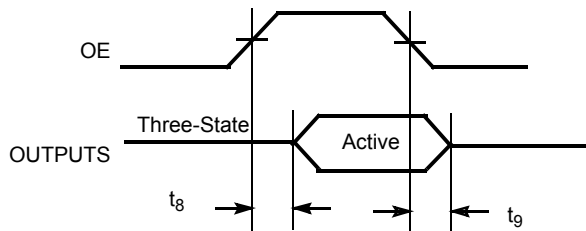
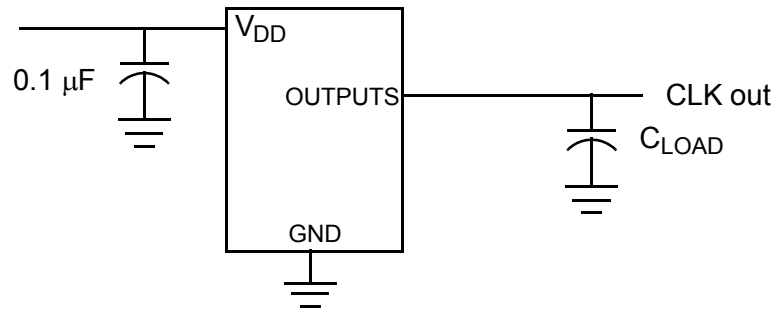
**Output-Output Skew**

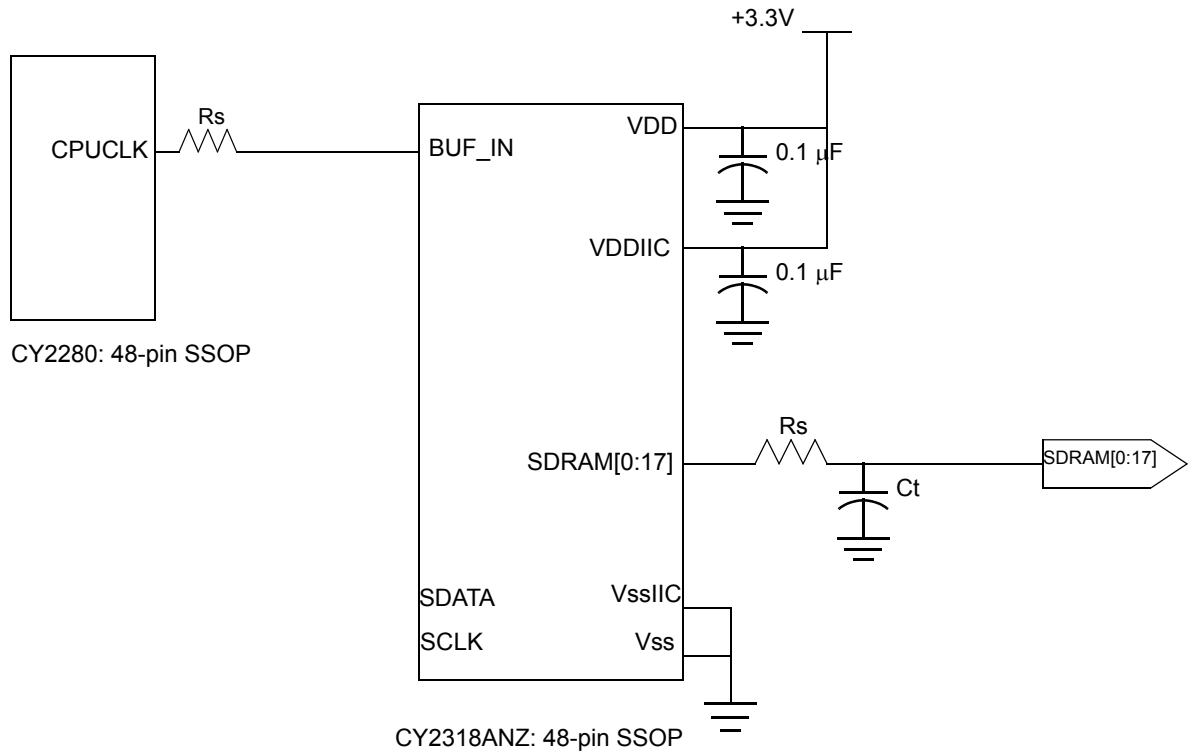
**Notes:**

4. All parameters specified with loaded outputs.
5. Duty cycle of input clock is 50%. Rising and falling edge rate is greater than 1 V/ns.

**Switching Waveforms (continued)**
**SDRAM Buffer LH and HL Propagation Delay**

**SDRAM Buffer Enable and Disable Times**

**Test Circuit**

**Application Circuit**

Rs = Series termination resistor  
 Ct = Optional cap to reduce EMI

**Ordering Information**

Ordering Code	Package Type	Operating Range
CY2318ANZPVC-11	48-pin SSOP	Commercial
CY2318ANZPVC-11T	48-pin SSOP - Tape and Reel	Commercial
<b>Lead-free</b>		
CY2318ANZOXC-11	48-pin SSOP	Commercial
CY2318ANZOXC-11T	48-pin SSOP- Tape and Reel	Commercial

Package Diagram

48-Lead Shrunken Small Outline Package O48

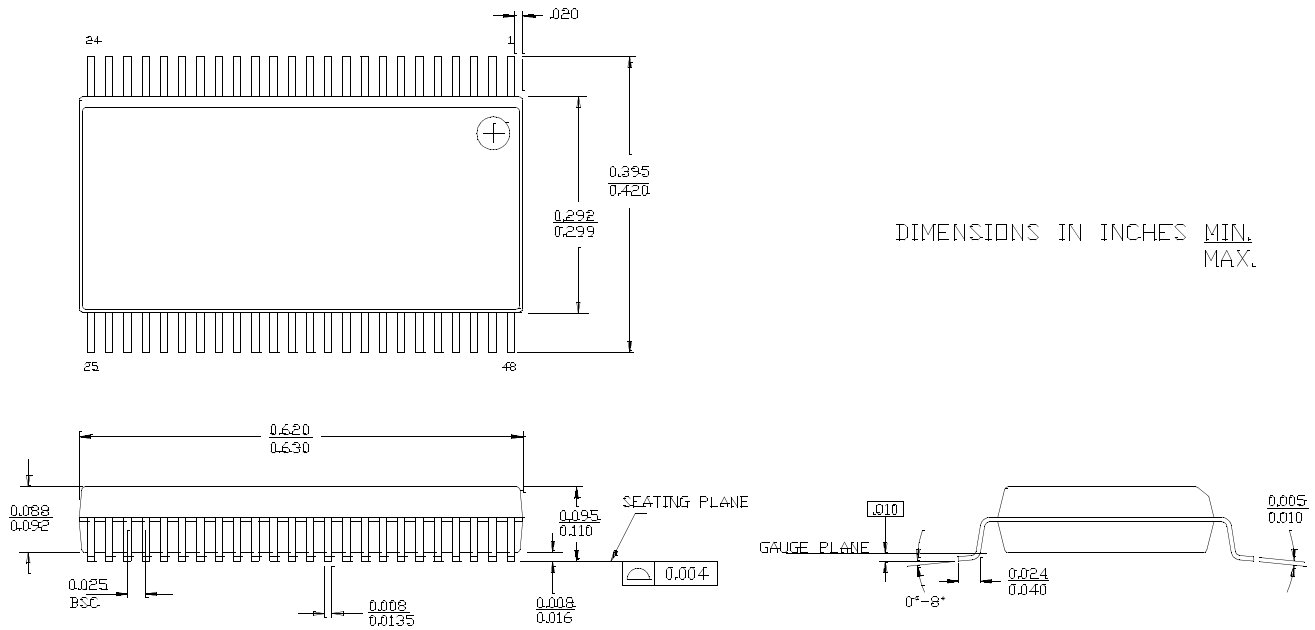

51-85061-°C

Pentium II is a registered trademark of Intel Corporation. All products and company names mentioned in this document may be the trademarks of their respective holders.





**Document History Page**

<b>Document Title: CY2318ANZ 18 Output, 3.3V SDRAM Buffer for Desktop PCs with 4 DIMMs</b>				
<b>Document Number: 38-07181</b>				
<b>REV.</b>	<b>ECN NO.</b>	<b>Issue Date</b>	<b>Orig. of Change</b>	<b>Description of Change</b>
**	111857	12/09/01	DSG	Change from Spec number: 38-00771 to 38-07181
*A	121833	12/14/02	RBI	Power up requirements added to Operating Conditions Information
*B	310577	See ECN	RGL	Added Tape and Reel option Added Lead-free Devices