



LT1108

Micropower DC/DC Converter

Adjustable and Fixed 5V, 12V

FEATURES

- Operates at Supply Voltages from 2V to 30V
- Consumes Only 110µA Supply Current
- Works in Step-Up or Step-Down Mode
- Only Four External Components Required
- Low Battery Detector Comparator On-Chip
- User Adjustable Current Limit
- Internal 1A Power Switch
- Fixed or Adjustable Output Voltage Versions
- Space Saving 8-Pin MiniDIP or S8 Package

APPLICATIONS

- Palmtop Computers
- 3V to 5V, 5V to 12V Converters
- 9V to 5V, 12V to 5V Converters
- LCD Bias Generators
- Peripherals and Add-On Cards
- Battery Backup Supplies
- Cellular Telephones
- Portable Instruments

DESCRIPTION

The LT1108 is a versatile micropower DC/DC converter. The device requires only four external components to deliver a fixed output of 5V or 12V. Supply voltage ranges from 2V to 12V in step-up mode and to 30V in step-down mode. The LT1108 functions equally well in step-up, step-down, or inverting applications.

The LT1108 is pin-for-pin compatible with the LT1173, but has a duty cycle of 70%, resulting in increased output current in many applications. The LT1108 can deliver 150mA at 5V from a 2 AA cell input and 5V at 300mA from 9V in step-down mode. Quiescent current is just 110µA, making the LT1108 ideal for power conscious battery-operated systems.

Switch current limit can be programmed with a single resistor. An auxiliary gain block can be configured as a low battery detector, linear post regulator, undervoltage lock-out circuit, or error amplifier.

TYPICAL APPLICATION

Palmtop Computer Logic Supply

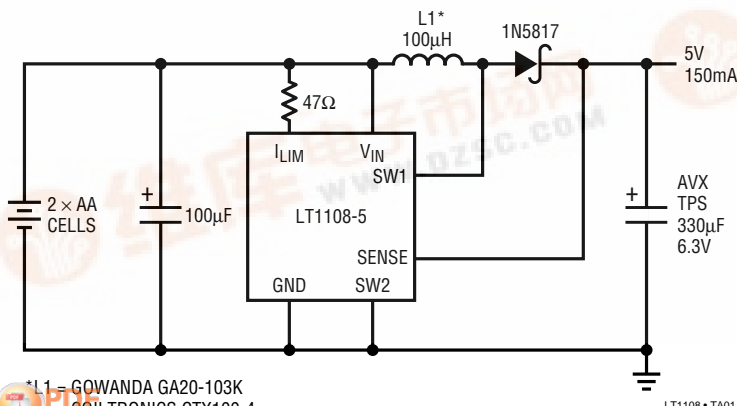

*L1 = GOWANDA GA20-103K
COIL TRONICS CTX100-4
SUNIDA CD105-101K

LT1108 • TA01

Efficiency

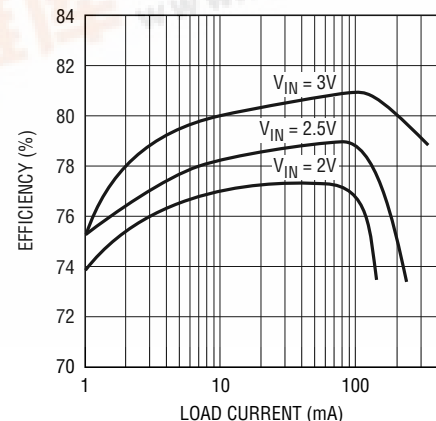

LT1108 • TA02



LT1108

ABSOLUTE MAXIMUM RATINGS

Supply Voltage (V_{IN})	36V	Maximum Power Dissipation	500mW
SW1 Pin Voltage (V_{SW1})	50V	Maximum Switch Current	1.5A
SW2 Pin Voltage (V_{SW2})	-0.5V to V_{IN}	Operating Temperature Range	0°C to 70°C
Feedback Pin Voltage (LT1108)	5.5V	Storage Temperature Range	-65°C to 150°C
Sense Pin Voltage (LT1108, -5, -12)	36V	Lead Temperature (Soldering, 10 sec)	300°C

PACKAGE/ORDER INFORMATION

<p>N8 PACKAGE 8-LEAD PLASTIC DIP *FIXED VERSIONS $T_{JMAX} = 90^{\circ}\text{C}$, $\theta_{JA} = 130^{\circ}\text{C/W}$</p>	ORDER PART NUMBER	<p>S8 PACKAGE 8-LEAD PLASTIC SOIC *FIXED VERSIONS $T_{JMAX} = 90^{\circ}\text{C}$, $\theta_{JA} = 150^{\circ}\text{C/W}$</p>	ORDER PART NUMBER
	LT1108CN8 LT1108CN8-5 LT1108CN8-12		LT1108CS8 LT1108CS8-5 LT1108CS8-12
		S8 PART MARKING	
		1108 10805 10812	

ELECTRICAL CHARACTERISTICS $T_A = 25^{\circ}\text{C}$, $V_{IN} = 3\text{V}$, unless otherwise noted.

SYMBOL	PARAMETER	CONDITIONS	MIN	TYP	MAX	UNITS	
I_Q	Quiescent Current	Switch OFF	●	110	150	μA	
	Quiescent Current, Boost Mode Configuration	No Load LT1108-5 LT1108-12		135 250		μA μA	
V_{IN}	Input Voltage	Step-Up Mode Step-Down Mode	● ●	2	12.6 30.0	V V	
	Comparator Trip Point Voltage	LT1108 (Note 1)	●	1.2	1.245	1.3	V
V_{OUT}	Output Sense Voltage	LT1108-5 (Note 2) LT1108-12 (Note 2)	● ●	4.75 11.4	5 12	5.25 12.6	V V
	Comparator Hysteresis	LT1108	●		5	10	mV
	Output Hysteresis	LT1108-5 LT1108-12	● ●		20 50	40 100	mV mV
f_{OSC}	Oscillator Frequency		●	14	19	25	kHz
	Duty Cycle	Full Load, Step-Up Mode	●	63	70	78	%
t_{ON}	Switch-ON Time	I_{LIM} Tied to V_{IN} , Step-Up Mode	●	28	36	48	μs
	Feedback Pin Bias Current	LT1108, $V_{FB} = 0\text{V}$	●		10	50	nA
	Set Pin Bias Current	$V_{SET} = V_{REF}$	●		20	100	nA
V_{OL}	Gain Block Output Low	$I_{SINK} = 100\mu\text{A}$, $V_{SET} = 1\text{V}$	●		0.15	0.4	V
	Reference Line Regulation	$2\text{V} \leq V_{IN} \leq 5\text{V}$	●		0.20	0.400	%/V
		$5\text{V} \leq V_{IN} \leq 30\text{V}$	●		0.02	0.075	%/V
V_{SAT}	SW _{SAT} Voltage, Step-Up Mode	$V_{IN} = 3\text{V}$, $I_{SW} = 650\text{mA}$	●		0.5	0.65	V
		$V_{IN} = 5\text{V}$, $I_{SW} = 1\text{A}$			0.8	1.00	V

ELECTRICAL CHARACTERISTICS $T_A = 25^\circ\text{C}$, $V_{IN} = 3\text{V}$, unless otherwise noted.

SYMBOL	PARAMETER	CONDITIONS	MIN	TYP	MAX	UNITS
V_{SAT}	SW _{SAT} Voltage, Step-Down Mode	$V_{IN} = 12\text{V}$, $I_{SW} = 650\text{mA}$	●	1.1	1.5	V
					1.7	V
A_V	Gain Block Gain	$R_L = 100\text{k}$ (Note 3)	●	400	1000	V/V
	Current Limit	220Ω from I_{LIM} to V_{IN}		400		mA
	Current Limit Temperature Coefficient		●	-0.3		%/ $^\circ\text{C}$
	Switch OFF Leakage Current	Measured at SW1 Pin		1	10	μA
V_{SW2}	Maximum Excursion Below GND	$I_{SW1} \leq 10\mu\text{A}$, Switch OFF		-400	-350	mV

The ● denotes specifications which apply over the full operating temperature range.

Note 1: This specification guarantees that both the high and low trip points of the comparator fall within the 1.2V to 1.3V range.

Note 2: The output voltage waveform will exhibit a sawtooth shape due to the comparator hysteresis. The output voltage on the fixed output versions will always be within the specified range.

Note 3: 100k resistor connected between a 5V source and the A0 pin.

TYPICAL PERFORMANCE CHARACTERISTICS

Saturation Voltage Step-Up Mode (SW2 Pin Grounded)

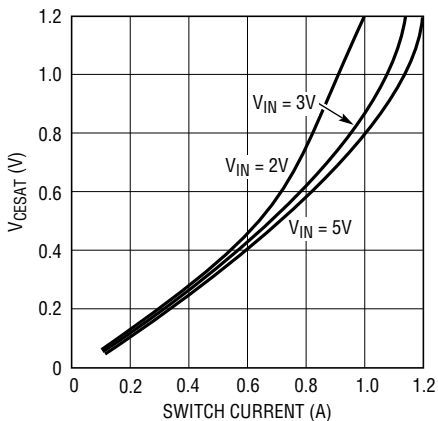

LT1108 • TPC01

Switch ON Voltage Step-Down Mode (SW1 Pin Connected to V_IN)

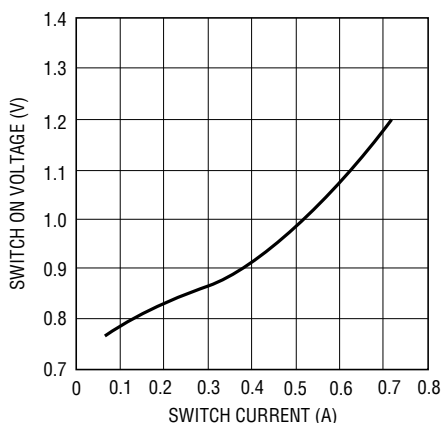

LT1108 • TPC02

Maximum Switch Current vs R_LIM

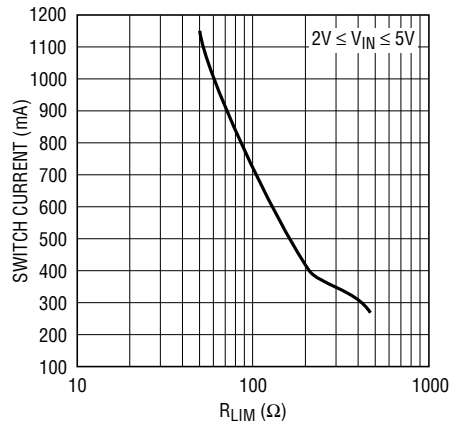

LT1108 • TPC03

Saturation Voltage Step-Up Mode (SW2 Pin Grounded)

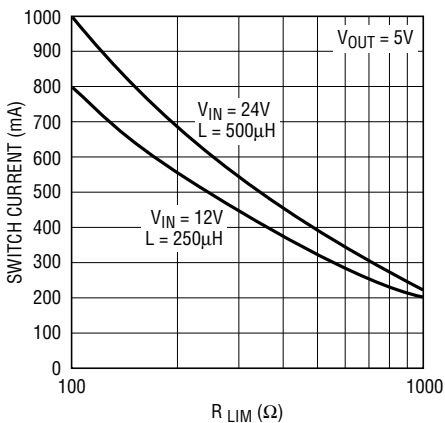

LT1108 • TPC04

Supply Current vs Switch Current

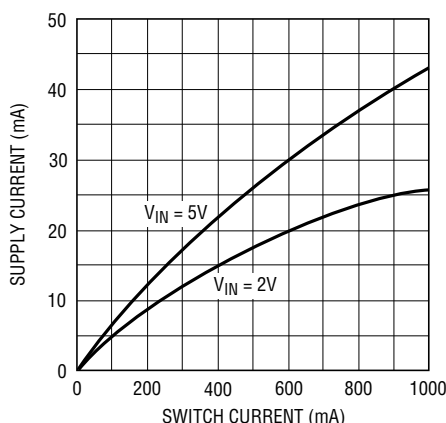

LT1108 • TPC05

Quiescent Current

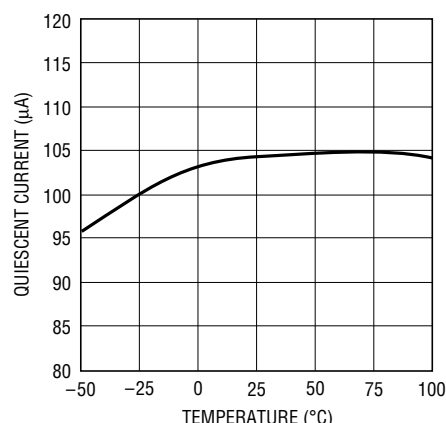

LT1108 • TPC06

LT1108

TYPICAL PERFORMANCE CHARACTERISTICS

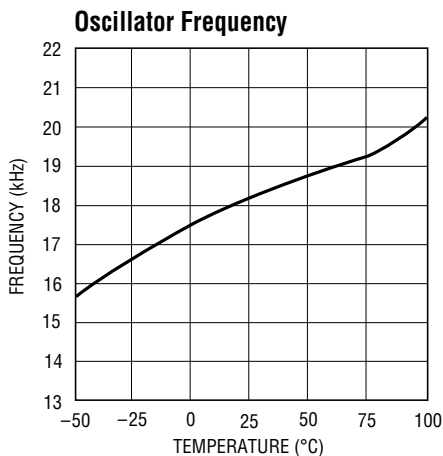

LT1108 • TPC07

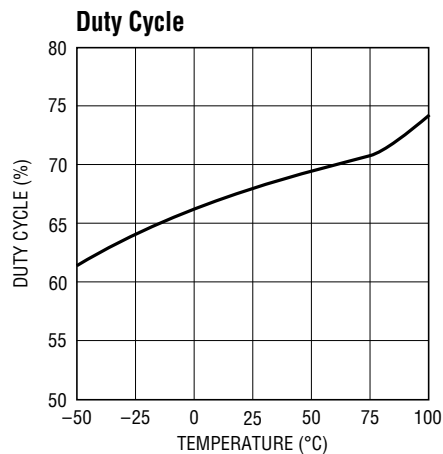

LT1108 • TPC08

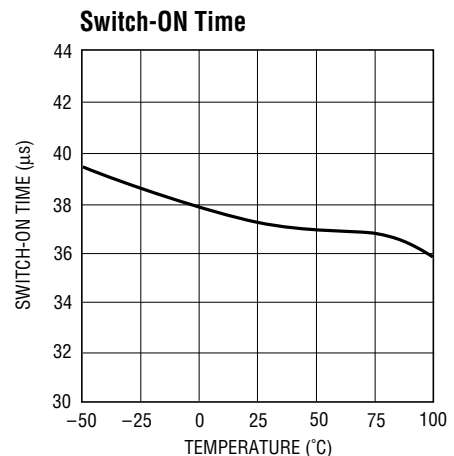

LT1108 • TPC09

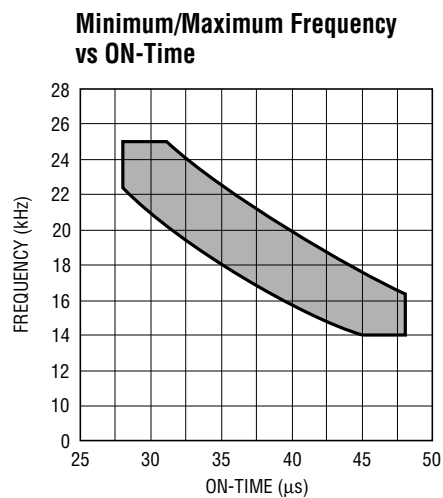

LT1108 • TPC10

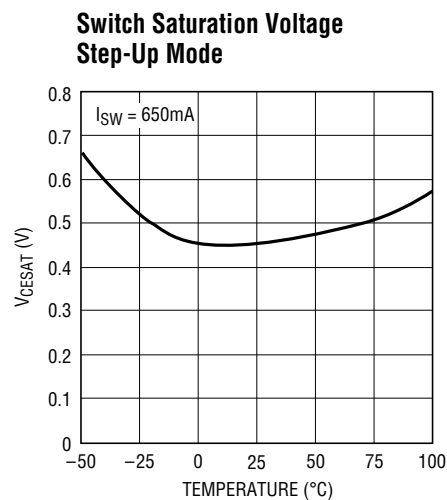

LT1108 • TPC11

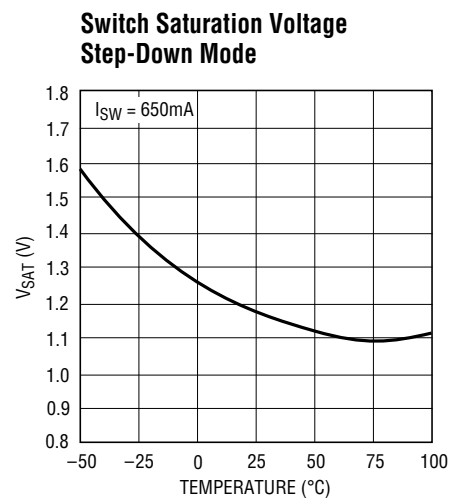

LT1108 • TPC12

PIN FUNCTIONS

I_{LIM} (Pin 1): Connect this pin to V_{IN} for normal use. Where lower current limit is desired, connect a resistor between I_{LIM} and V_{IN} . A 220Ω resistor will limit the switch current to approximately 400mA.

V_{IN} (Pin 2): Input supply voltage.

SW1 (Pin 3): Collector of power transistor. For step-up mode connect to inductor/diode. For step-down mode connect to V_{IN} .

SW2 (Pin 4): Emitter of power transistor. For step-up mode connect to ground. For step-down mode connect to inductor/diode. This pin must never be allowed to go more than a Schottky diode drop below ground.

GND (Pin 5): Ground.

AO (Pin 6): Auxiliary gain block (GB) output. Open collector, can sink 100μA.

SET (Pin 7): GB input. GB is an op amp with positive input connected to SET pin and negative input connected to 1.245V reference.

FB/SENSE (Pin 8): On the LT1108 (adjustable) this pin goes to the comparator input. On the LT1108-5 and LT1108-12, this pin goes to the internal application resistor that sets output voltage.

OPERATION

The LT1108 is a gated oscillator switcher. This type architecture has very low supply current because the switch is cycled when the feedback pin voltage drops below the reference voltage. Circuit operation can best be understood by referring to the LT1108 block diagram. Comparator A1 compares the feedback (FB) pin voltage with the 1.245V reference signal. When FB drops below 1.245V, A1 switches on the 19kHz oscillator. The driver amplifier boosts the signal level to drive the output NPN power switch. The switch cycling action raises the output voltage and FB pin voltage. When the FB voltage is sufficient to trip A1, the oscillator is gated off. A small amount of hysteresis built into A1 ensures loop stability without external frequency compensation. When the comparator output is low, the oscillator and all high current circuitry is turned off, lowering device quiescent current to just 110 μ A.

The oscillator is set internally for 36 μ s ON-time and 17 μ s OFF-time, allowing continuous mode operation in many cases such as 2V to 5V converters. Continuous mode greatly increases available output power.

Gain block A2 can serve as a low battery detector. The

negative input of A2 is the 1.245V reference. A resistor divider from V_{IN} to GND, with the mid-point connected to the SET pin provides the trip voltage in a low battery detector application. A0 can sink 100 μ A (use a 47k resistor pull-up to 5V).

A resistor connected between the I_{LIM} pin and V_{IN} sets maximum switch current. When the switch current exceeds the set value, the switch cycle is prematurely terminated. If current limit is not used, I_{LIM} should be tied directly to V_{IN} . Propagation delay through the current-limit circuitry is approximately 2 μ s.

In step-up mode the switch emitter (SW2) is connected to ground and the switch collector (SW1) drives the inductor; in step-down mode the collector is connected to V_{IN} and the emitter drives the inductor.

The LT1108-5 and LT1108-12 are functionally identical to the LT1108. The -5 and -12 versions have on-chip voltage setting resistors for fixed 5V or 12V outputs. Pin 8 on the fixed versions should be connected to the output. No external resistors are needed.

BLOCK DIAGRAMS

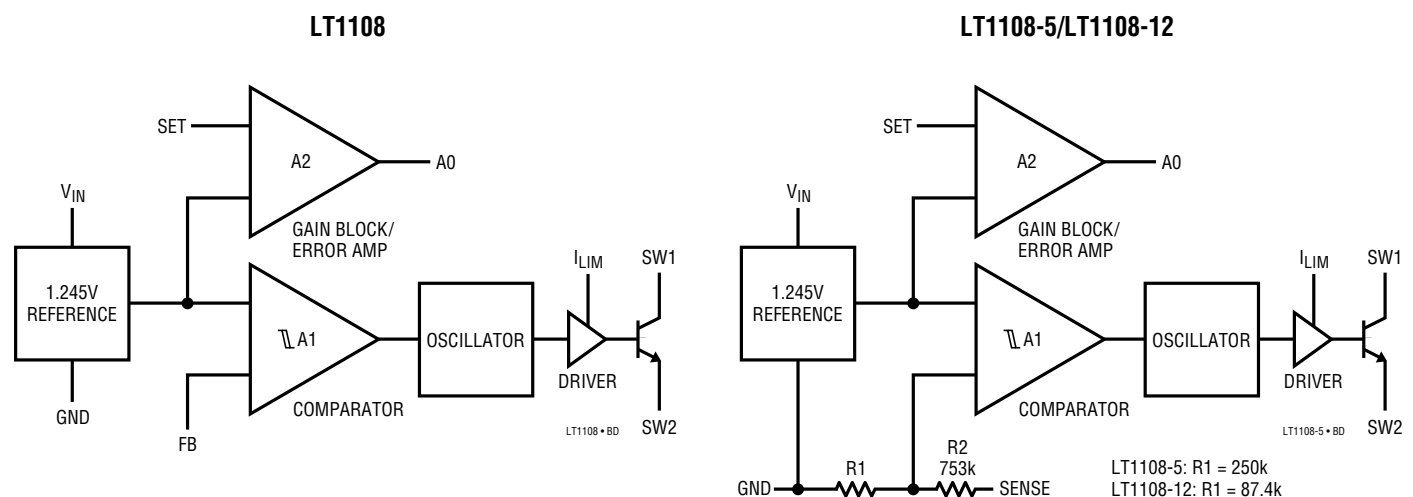

APPLICATIONS INFORMATION

INDUCTOR SELECTION

General

A DC/DC converter operates by storing energy as magnetic flux in an inductor core, and then switching this energy into the load. Since it is flux, not charge, that is stored, the output voltage can be higher, lower, or opposite in polarity to the input voltage by choosing an appropriate switching topology.

To operate as an efficient energy transfer element, the inductor must fulfill three requirements. First, the inductance must be low enough for the inductor to store adequate energy under the worst case condition of minimum input voltage and switch-ON time. The inductance must also be high enough so maximum current ratings of the LT1108 and inductor are not exceeded at the other worst case condition of maximum input voltage and ON-time.

Additionally, the inductor core must be able to store the required flux; i.e., it must not *saturate*. At power levels generally encountered with LT1108 based designs, small surface mount ferrite core units with saturation current ratings in the 300mA to 1A range and DCR less than 0.4Ω (depending on application) are adequate.

Lastly, the inductor must have sufficiently low DC resistance so excessive power is not lost as heat in the windings. An additional consideration is Electro-Magnetic Interference (EMI). Toroid and pot core type inductors are recommended in applications where EMI must be kept to a minimum; for example, where there are sensitive analog circuitry or transducers nearby. Rod core types are a less expensive choice where EMI is not a problem. Minimum and maximum input voltage, output voltage and output current must be established before an inductor can be selected.

Step-Up Converter

In a step-up, or boost converter (Figure 1), power generated by the inductor makes up the difference between input and output. Power required from the inductor is determined by

$$P_L = (V_{OUT} + V_D - V_{IN\ MIN}) (I_{OUT}) \quad (01)$$

where V_D is the diode drop (0.5V for a 1N5818 Schottky). Energy required by the inductor per cycle must be equal or greater than

$$P_L / f_{OSC} \quad (02)$$

in order for the converter to regulate the output.

When the switch is closed, current in the inductor builds according to

$$I_L(t) = \frac{V_{IN}}{R'} \left(1 - e^{-\frac{R't}{L}} \right) \quad (03)$$

where R' is the sum of the switch equivalent resistance (0.8Ω typical at 25°C) and the inductor DC resistance. When the drop across the switch is small compared to V_{IN} , the simple lossless equation

$$I_L(t) = \frac{V_{IN}}{L} t \quad (04)$$

can be used. These equations assume that at $t = 0$, inductor current is zero. This situation is called “discontinuous mode operation” in switching regulator parlance. Setting “ t ” to the switch-ON time from the LT1108 specification table (typically 36μs) will yield I_{PEAK} for a specific “ L ” and V_{IN} . Once I_{PEAK} is known, energy in the inductor at the end of the switch-ON time can be calculated as

$$E_L = \frac{1}{2} L I_{PEAK}^2 \quad (05)$$

E_L must be greater than P_L / f_{OSC} for the converter to deliver the required power. For best efficiency I_{PEAK} should be kept to 1A or less. Higher switch currents will cause excessive drop across the switch resulting in reduced efficiency. In general, switch current should be held to as low a value as possible in order to keep switch, diode and inductor losses at a minimum.

As an example, suppose 12V at 30mA is to be generated from a 2V to 3V input. Recalling equation (01),

$$P_L = (12V + 0.5V - 2V)(30mA) = 315mW \quad (06)$$

APPLICATIONS INFORMATION

Energy required from the inductor is

$$\frac{P_L}{f_{OSC}} = \frac{315\text{mW}}{19\text{kHz}} = 16.6\mu\text{J} \quad (07)$$

Picking an inductor value of 100μH with 0.2Ω DCR results in a peak switch current of

$$I_{PEAK} = \frac{2V}{1.0\Omega} \left(1 - e^{-\frac{1.0\Omega \times 36\mu\text{s}}{100\mu\text{H}}} \right) = 605\text{mA} \quad (08)$$

Substituting I_{PEAK} into Equation 04 results in

$$E_L = \frac{1}{2} (100\mu\text{H}) (6.605\text{A})^2 = 18.3\mu\text{J} \quad (09)$$

Since 18.3μJ > 16.6μJ, the 100μH inductor will work. This trial-and-error approach can be used to select the optimum inductor. Keep in mind the switch current maximum rating of 1.5A. If the calculated peak current exceeds this, an external power transistor can be used.

A resistor can be added in series with the I_{LIM} pin to invoke switch current limit. The resistor should be picked so the calculated I_{PEAK} at minimum V_{IN} is equal to the Maximum Switch Current (from Typical Performance Characteristic curves). Then, as V_{IN} increases, switch current is held constant, resulting in increasing efficiency.

Step-Down Converter

The step-down case (Figure 2) differs from the step-up in that the inductor current flows through the load during both the charge and discharge periods of the inductor. Current through the switch should be limited to ~650mA in this mode. Higher current can be obtained by using an external switch (see Figure 3). The I_{LIM} pin is the key to successful operation over varying inputs.

After establishing output voltage, output current and input voltage range, peak switch current can be calculated by the formula:

$$I_{PEAK} = \frac{2I_{OUT}}{DC} \left[\frac{V_{OUT} + V_D}{V_{IN} - V_{SW} + V_D} \right] \quad (10)$$

where DC = duty cycle (0.60)

V_{SW} = switch drop in step-down mode

V_D = diode drop (0.5V for a 1N5818)

I_{OUT} = output current

V_{OUT} = output voltage

V_{IN} = minimum input voltage

V_{SW} is actually a function of switch current which is in turn a function of V_{IN} , L, time, and V_{OUT} . To simplify, 1.5V can be used for V_{SW} as a very conservative value.

Once I_{PEAK} is known, inductor value can be derived from

$$L = \frac{V_{IN\ MIN} - V_{SW} - V_{OUT}}{I_{PEAK}} \times t_{ON} \quad (11)$$

where t_{ON} = switch-ON time (36μs).

Next, the current limit resistor R_{LIM} is selected to give I_{PEAK} from the R_{LIM} Step-Down Mode curve. The addition of this resistor keeps maximum switch current constant as the input voltage is increased.

As an example, suppose 5V at 300mA is to be generated from a 12V to 24V input. Recalling Equation (10),

$$I_{PEAK} = \frac{2(300\text{mA})}{0.60} \left[\frac{5 + 0.5}{12 - 1.5 + 0.5} \right] = 500\text{mA} \quad (12)$$

Next, inductor value is calculated using Equation (11)

$$L = \frac{12 - 1.5 - 5}{500\text{mA}} 36\mu\text{s} = 396\mu\text{H} \quad (13)$$

Use the next lowest standard value (330μH).

Then pick R_{LIM} from the curve. For $I_{PEAK} = 500\text{mA}$, $R_{LIM} = 220\Omega$.

Positive-to-Negative Converter

Figure 4 shows hookup for positive-to-negative conversion. All of the output power must come from the inductor. In this case,

$$P_L = (|V_{OUT}| + V_D)(I_{OUT}) \quad (14)$$

APPLICATIONS INFORMATION

In this mode the switch is arranged in common collector or step-down mode. The switch drop can be modeled as a 0.75V source in series with a 0.65Ω resistor. When the switch closes, current in the inductor builds according to

$$I_L(t) = \frac{V_L}{R'} \left(1 - e^{-\frac{R't}{L}} \right) \quad (15)$$

where: $R' = 0.65\Omega + DCR_L$
 $V_L = V_{IN} - 0.75V$

As an example, suppose -5V at 100mA is to be generated from a 4.5V to 5.5V input. Recalling Equation (14),

$$P_L = (|-5V| + 0.5V)(100mA) = 550mW. \quad (16)$$

Energy required from the inductor is

$$\frac{P_L}{f_{OSC}} = \frac{550mW}{19kHz} = 28.9\mu J \quad (17)$$

Picking an inductor value of 220μH with 0.3Ω DCR results in a peak switch current of

$$I_{PEAK} = \frac{(4.5V - 0.75V)}{(0.65\Omega + 0.3\Omega)} \left(1 - e^{-\frac{0.95\Omega \times 36\mu s}{220\mu H}} \right) \quad (18)$$

$$= 568mA$$

Substituting I_{PEAK} into Equation (04) results in

$$E_L = \frac{1}{2} (220\mu H) (0.568A)^2 = 35.5\mu J \quad (19)$$

Since 35.5μJ > 28.9μJ, the 220μH inductor will work.

Finally, R_{LIM} should be selected by looking at the Switch Current vs R_{LIM} curve. In this example, $R_{LIM} = 150\Omega$.

STEP-UP (BOOST MODE) OPERATION

A step-up DC/DC converter delivers an output voltage higher than the input voltage. Step-up converters are not short-circuit protected since there is a DC path from input to output.

The usual step-up configuration for the LT1108 is shown in Figure 1. The LT1108 first pulls SW1 low causing $V_{IN} - V_{CESAT}$ to appear across L1. A current then builds up in L1. At the end of the switch-ON time the current in L1 is

$$I_{PEAK} = \frac{V_{IN}}{L} t_{ON}^* \quad (20)$$

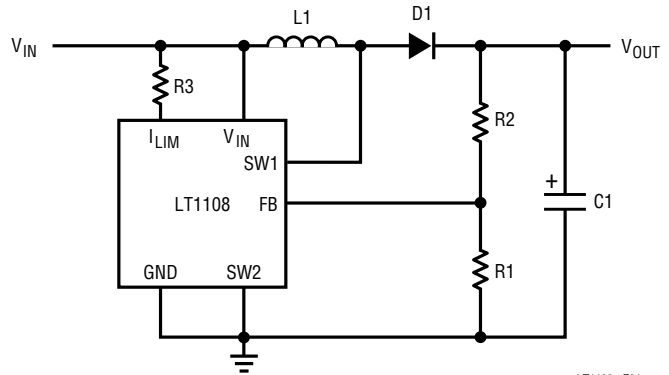

Figure 1. Step-Up Mode Hookup

Immediately after switch turn-off, the SW1 voltage pin starts to rise because current cannot instantaneously stop flowing in L1. When the voltage reaches $V_{OUT} + V_D$, the inductor current flows through D1 into C1, increasing V_{OUT} . This action is repeated as needed by the LT1108 to keep V_{FB} at the internal reference voltage of 1.245V. R1 and R2 set the output voltage according to the formula

$$V_{OUT} = \left(1 + \frac{R2}{R1} \right) (1.245V) \quad (21)$$

STEP-DOWN (BUCK MODE) OPERATION

A step-down DC/DC converter converts a higher voltage to a lower voltage. The usual hookup for an LT1108 based step-down converter is shown in Figure 2.

When the switch turns on, SW2 pulls up to $V_{IN} - V_{SW}$. This puts a voltage across L1 equal to $V_{IN} - V_{SW} - V_{OUT}$, causing a current to build up in L1. At the end of the switch-ON time, the current in L1 is equal to

*Expression 20 neglects the effect of switch and coil resistance. This is taken into account in the "Inductor Selection" section.

APPLICATIONS INFORMATION

$$I_{PEAK} = \frac{V_{IN} - V_{SW} - V_{OUT}}{L} t_{ON} \quad (22)$$

When the switch turns off, the SW2 pin falls rapidly and actually goes below ground. D1 turns on when SW2 reaches 0.4V below ground. *D1 MUST BE A SCHOTTKY DIODE*. The voltage at SW2 must never be allowed to go below -0.5V. A silicon diode such as the 1N4933 will allow SW2 to go to -0.8V, causing potentially destructive power dissipation inside the LT1108. Output voltage is determined by

$$V_{OUT} = \left(1 + \frac{R2}{R1}\right) (1.245V) \quad (23)$$

R3 programs switch current limit. This is especially important in applications where the input varies over a wide range. Without R3, the switch stays on for a fixed time each cycle. Under certain conditions the current in L1 can build up to excessive levels, exceeding the switch rating and/or saturating the inductor. The 100Ω resistor programs the switch to turn off when the current reaches approximately 700mA. When using the LT1108 in step-down mode, output voltage should be limited to 6.2V or less. Higher output voltages can be accommodated by inserting a 1N5818 diode in series with the SW2 pin (anode connected to SW2).

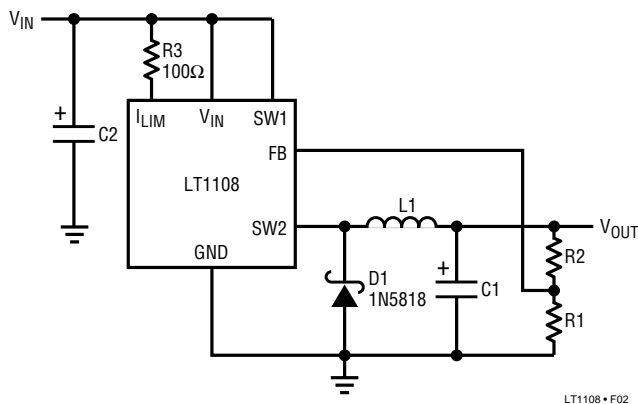

Figure 2. Step-Down Mode Hookup

HIGHER CURRENT STEP-DOWN OPERATION

Output current can be increased by using a discrete PNP pass transistor as shown in Figure 3. R1 serves as a current limit sense. When the voltage drop across R1 equals 0.5V_{BE}, the switch turns off. As shown, switch current is limited to 2A. Inductor value can be calculated based on formulas in the Inductor Selection Step-Down Converter section with the following conservative expression for V_{SW}:

$$V_{SW} = V_{R1} + V_{Q1SAT} \approx 1.0V \quad (24)$$

R2 provides a current path to turn off Q1. R3 provides base drive to Q1. R4 and R5 set output voltage. A PMOS FET can be used in place of Q1 when V_{IN} is between 10V and 20V.

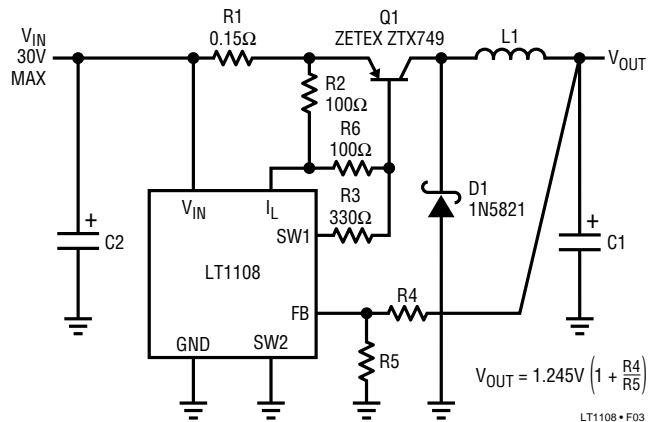

Figure 3. Q1 Permits Higher Current Switching The LT1108 Functions as Controller

INVERTING CONFIGURATIONS

The LT1108 can be configured as a positive-to-negative converter (Figure 4), or a negative-to-positive converter (Figure 5). In Figure 4, the arrangement is very similar to a step-down, except that the high side of the feedback is referred to ground. This level shifts the output negative. As in the step-down mode, D1 must be a Schottky diode, and |V_{OUT}| should be less than 6.2V. More negative output voltages can be accommodated as in the prior section.

In Figure 5, the input is negative while the output is positive. In this configuration, the magnitude of the input voltage can be higher or lower than the output voltage. A level shift,

APPLICATIONS INFORMATION

provided by the PNP transistor, supplies proper polarity feedback information to the regulator.

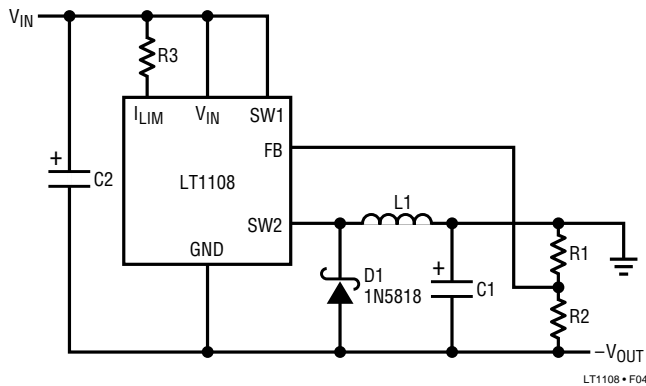

Figure 4. Positive-to-Negative Converter

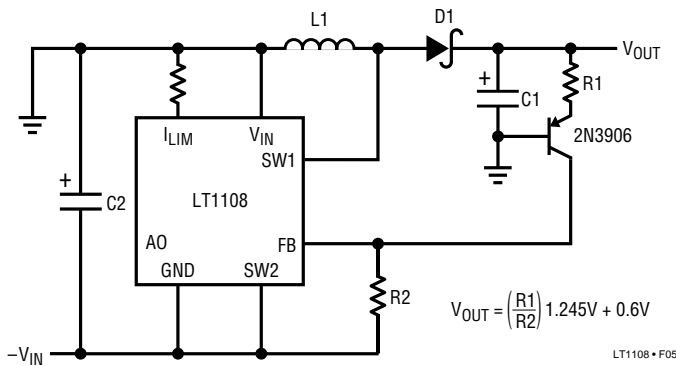

Figure 5. Negative-to-Positive Converter

USING THE I_{LIM} PIN

The LT1108 switch can be programmed to turn off at a set switch current, a feature not found on competing devices. This enables the input to vary over a wide range without exceeding the maximum switch rating or saturating the inductor. Consider the case where analysis shows the LT1108 must operate at an 800mA peak switch current with a 2.0V input. If V_{IN} rises to 4V, the peak switch current will rise to 1.6A, exceeding the maximum switch current rating. With the proper resistor selected (see the “Maximum Switch Current vs R_{LIM}” characteristic), the switch current will be limited to 800mA, even if the input voltage increases.

Another situation where the I_{LIM} feature is useful occurs when the device goes into continuous mode operation. This occurs in step-up mode when

$$\frac{V_{OUT} + V_{DIODE}}{V_{IN} - V_{SW}} < \frac{1}{1 - DC} \quad (25)$$

When the input and output voltages satisfy this relationship, inductor current does not go to zero during the switch-OFF time. When the switch turns on again, the current ramp starts from the non-zero current level in the inductor just prior to switch turn-on. As shown in Figure 6, the inductor current increases to a high level before the comparator turns off the oscillator. This high current can cause excessive output ripple and requires oversizing the output capacitor and inductor. With the I_{LIM} feature, however, the switch current turns off at a programmed level as shown in Figure 7, keeping output ripple to a minimum.

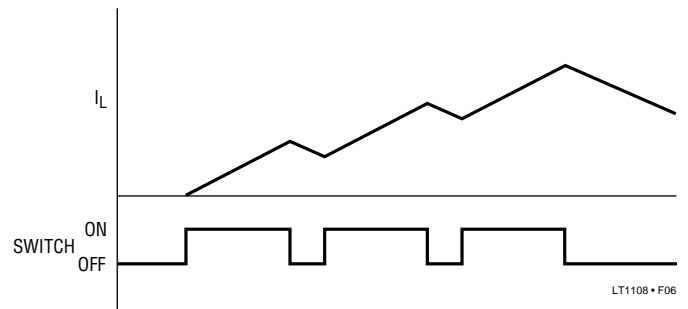

Figure 6. No Current Limit Causes Large Inductor Current Build-Up

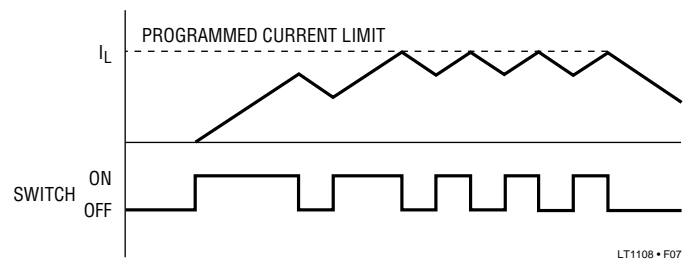

Figure 7. Current Limit Keeps Inductor Current Under Control

APPLICATIONS INFORMATION

Figure 8 details current limit circuitry. Sense transistor Q1, whose base and emitter are paralleled with power switch Q2, is ratioed such that approximately 0.5% of Q2's collector current flows in Q1's collector. This current passed through internal 80Ω resistor R1 and out through the I_{LIM} pin. The value of the external resistor connected between I_{LIM} and V_{IN} sets the current limit. When sufficient switch current flows to develop a V_{BE} across R1 + R_{LIM}, Q3 turns on and injects current into the oscillator, turning off the switch. Delay through this circuitry is approximately 2μs. The current trip point becomes less accurate for switch-ON times less than 5μs. Resistor values programming switch-ON time for 2μs or less will cause spurious response in the switch circuitry although the device will still maintain output regulation.

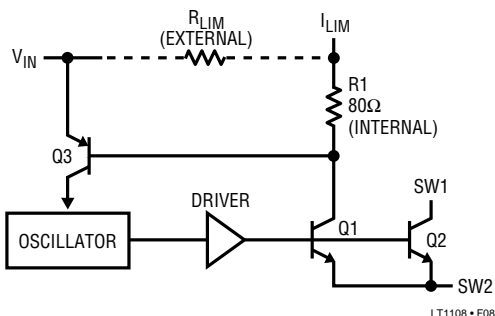

Figure 8. LT1108 Current Limit Circuitry

USING THE GAIN BLOCK

The gain block (GB) on the LT1108 can be used as an error amplifier, low battery detector or linear post regulator. The gain block itself is a very simple PNP input op amp with an open collector NPN output. The negative input of the gain block is tied internally to the 1.245V reference. The positive input comes out on the SET pin.

Arrangement of the gain block as a low battery detector is straightforward. Figure 9 shows hookup. R1 and R2 need only be low enough in value so that the bias current of the SET input does not cause large errors. 33k for R2 is adequate. R3 can be added to introduce a small amount of hysteresis. This will cause the gain block to “snap” when the trip point is reached. Values in the 1M to 10M range are optimal. The addition however, of R3 will change the trip point.

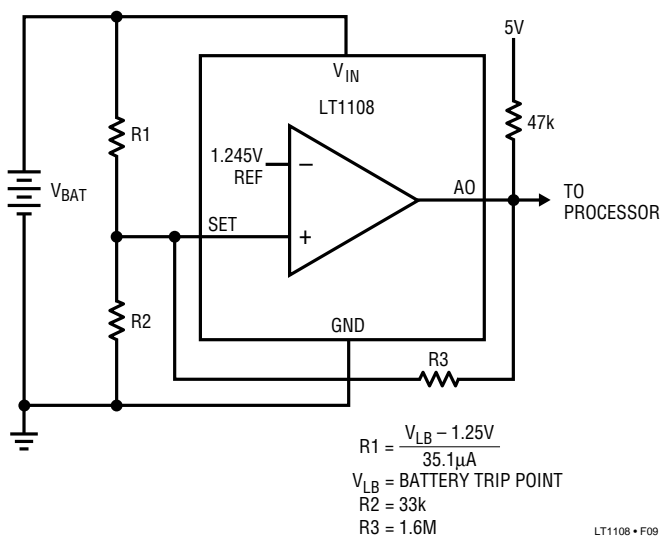

Figure 9. Setting Low Battery Detector Trip Point

Table 1. Inductor Manufacturers

MANUFACTURER	PART NUMBERS
Coiltronics International 984 S.W. 13th Court Pompano Beach, FL 33069 305-781-8900	OCTA-PAC™ Series
Sumida Electric Co. USA 708-956-0666	CD54 CDR74 CDR105

Table 2. Capacitor Manufacturers

MANUFACTURER	PART NUMBERS
Sanyo Video Components 1201 Sanyo Avenue San Diego, CA 92073 619-661-6322	OS-CON Series
Nichicon America Corporation 927 East State Parkway Schaumburg, IL 60173 708-843-7500	PL Series
AVX Corporation Myrtle Beach, SC 803-946-0690	TPS Series

Table 3. Transistor Manufacturers

MANUFACTURER	PART NUMBERS
Zetex Inc. 87 Modular Avenue Commack, NY 11725 516-543-7100	ZTX 749 (NPN) ZTX 849 (NPN) ZTX 949 (PNP)

LT1108

TYPICAL APPLICATIONS

5V to -5V Converter

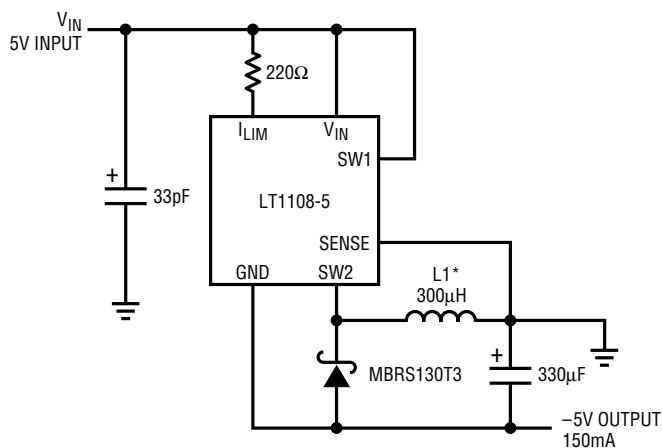

* L1 = COILTRONICS CTX300-4

LT1108 • TA03

6.5V-20V to 5V Step-Down Converter

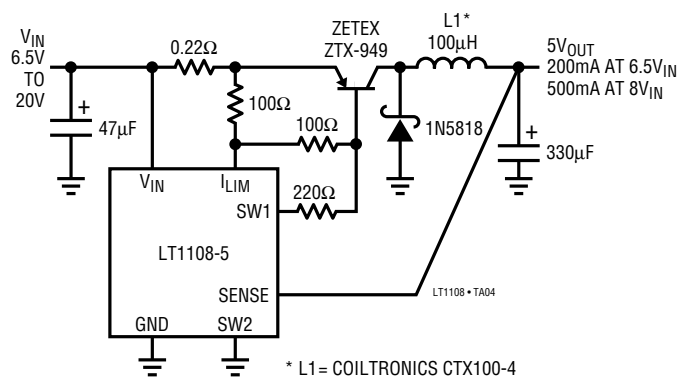

* L1 = COILTRONICS CTX100-4

PACKAGE DESCRIPTION

Dimensions in inches (millimeters) unless otherwise noted.

N8 Package 8-Lead Plastic DIP

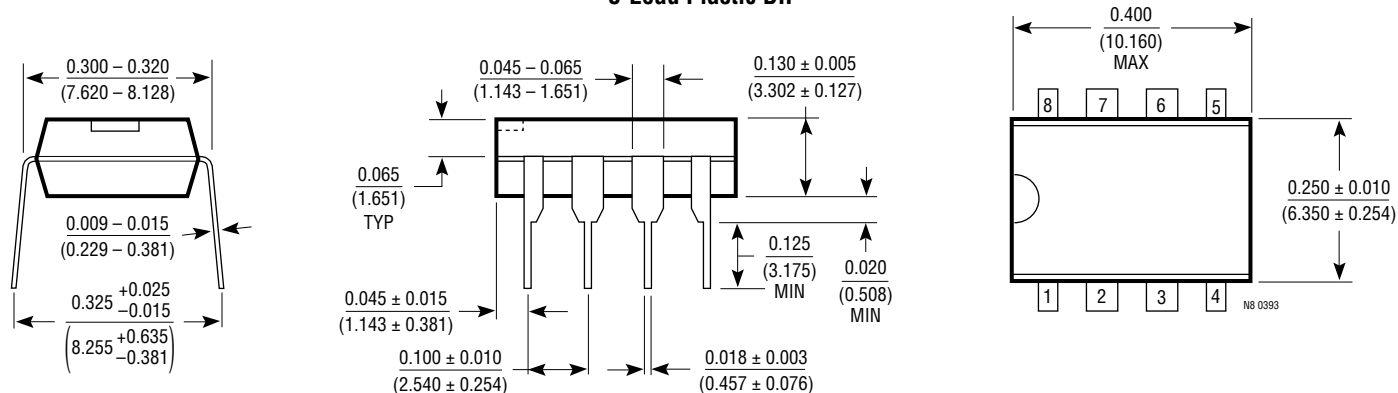

S8 Package 8-Lead Plastic SOIC

