



CYPRESS

CY7C1298F

# 1-Mbit (64K x 18) Pipelined DCD Sync SRAM

## Features

- Registered inputs and outputs for pipelined operation
- Optimal for performance (Double-Cycle deselect)
  - Depth expansion without wait state
- 64K x 18-bit common I/O architecture
- 3.3V -5% and +10% core power supply ( $V_{DD}$ )
- 3.3V I/O supply ( $V_{DDQ}$ )
- Fast clock-to-output times
  - 3.5ns (for 166-MHz device)
  - 4.0ns (for 133-MHz device)
- Provide high-performance 3-1-1 access rate
- User-selectable burst counter supporting Intel® Pentium® interleaved or linear burst sequences
- Separate processor and controller address strobes
- Synchronous self-timed writes
- Asynchronous Output Enable
- JEDEC-standard 100-pin TQFP package and pinout
- “ZZ” Sleep Mode option

## Functional Description<sup>[1]</sup>

The CY7C1298F SRAM integrates 65,536x18 SRAM cells with advanced synchronous peripheral circuitry and a two-bit counter for internal burst operation. All synchronous inputs are gated by registers controlled by a positive-edge-triggered Clock Input (CLK). The synchronous inputs include all addresses, all data inputs, address-pipelining Chip Enable ( $\overline{CE}_1$ ), depth-expansion Chip Enables ( $\overline{CE}_2$  and  $\overline{CE}_3$ ), Burst Control inputs ( $\overline{ADSC}$ ,  $\overline{ADSP}$ , and  $\overline{ADV}$ ), Write Enables ( $\overline{BW}_{[A:B]}$  and  $\overline{BWE}$ ), and Global Write ( $\overline{GW}$ ). Asynchronous inputs include the Output Enable ( $\overline{OE}$ ) and the ZZ pin.

Addresses and chip enables are registered at rising edge of clock when either Address Strobe Processor ( $\overline{ADSP}$ ) or Address Strobe Controller ( $\overline{ADSC}$ ) are active. Subsequent burst addresses can be internally generated as controlled by the Advance pin ( $\overline{ADV}$ ).

Address, data inputs, and write controls are registered on-chip to initiate a self-timed Write cycle. This part supports Byte Write operations (see Pin Descriptions and Truth Table for further details). Write cycles can be one to two bytes wide as controlled by the byte write control inputs.  $\overline{GW}$  active LOW causes all bytes to be written. This device incorporates an additional pipelined enable register which delays turning off the output buffers an additional cycle when a deselect is executed. This feature allows depth expansion without penalizing system performance.

The CY7C1298F operates from a +3.3V core power supply while all outputs operate with a +3.3V supply. All inputs and outputs are JEDEC-standard JESD8-5-compatible.

## Selection Guide

	166 MHz	133 MHz	Unit
Maximum Access Time	3.5	4.0	ns
Maximum Operating Current	240	225	mA
Maximum CMOS Standby Current	40	40	mA

Shaded areas contain advance information. Please contact your local Cypress sales representative for availability of these parts.

**Note:**

1. For best-practices recommendations, please refer to the Cypress application note *System Design Guidelines* on [www.cypress.com](http://www.cypress.com).



Functional Block Diagram—64Kx18

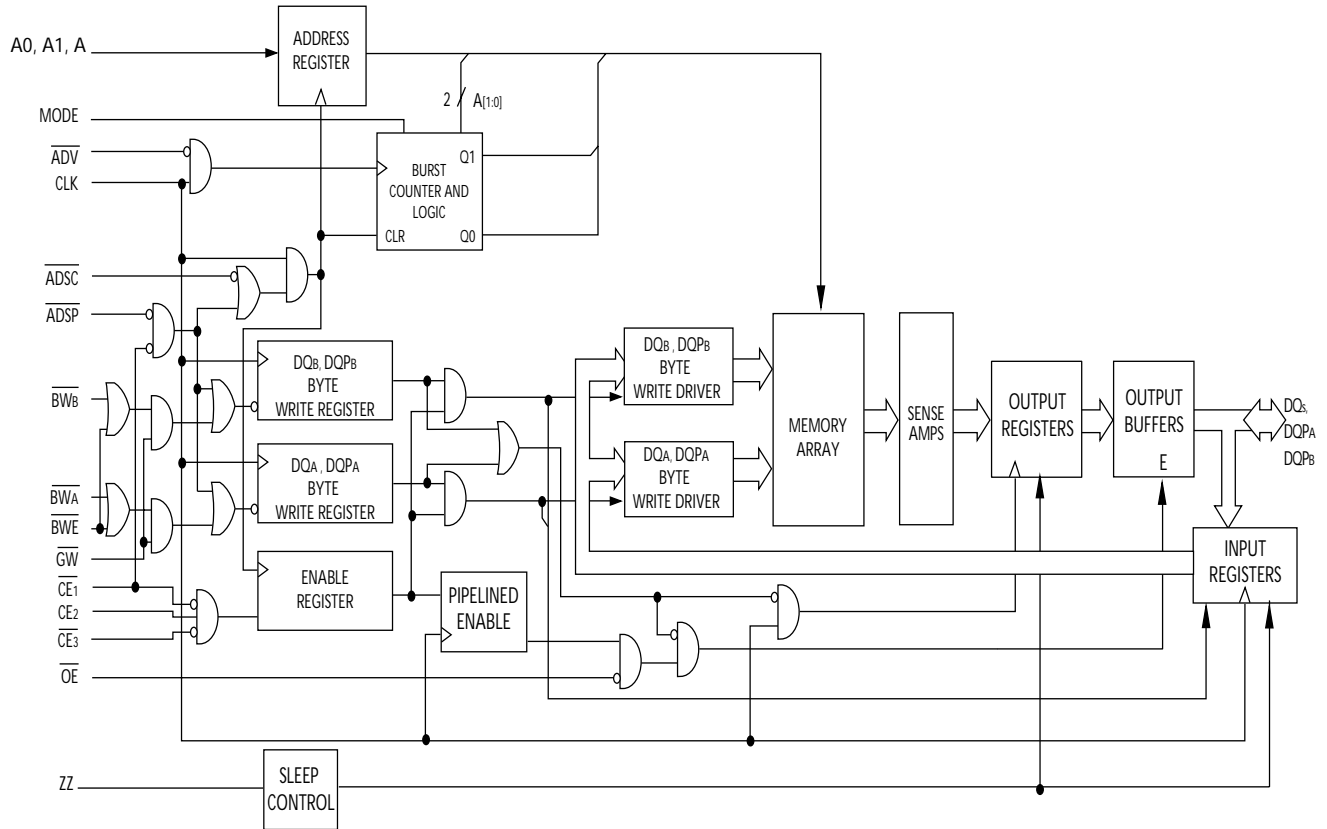

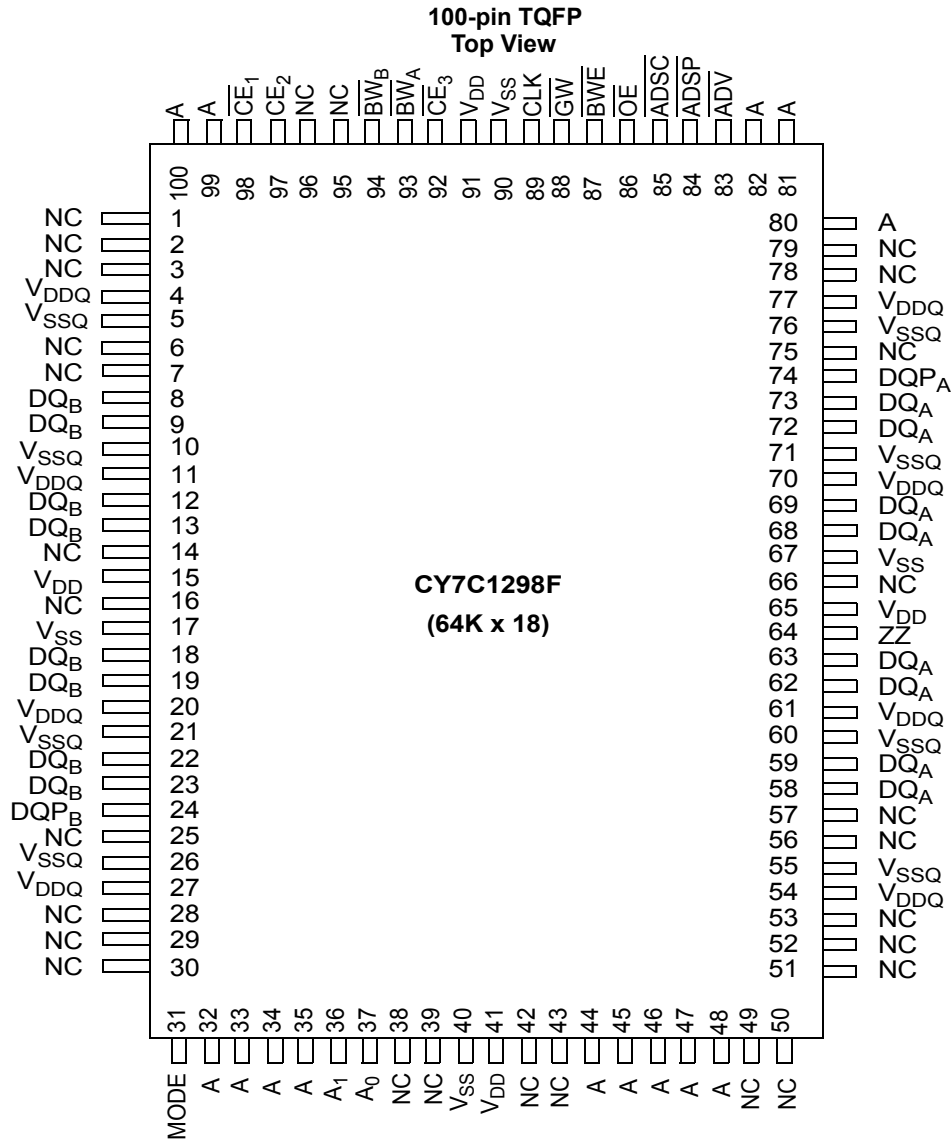
**Pin Configurations**

**Pin Descriptions**

Pin	TQFP	Type	Description
A0, A <sub>1</sub> , A	37,36,32,33 34,35,44,45, 46,47,48,80, 81,82,99,100	Input- Synchronous	<b>Address Inputs used to select one of the 64K address locations.</b> Sampled at the rising edge of the CLK if $\overline{ADSP}$ or $\overline{ADSC}$ is active LOW, and $\overline{CE}_1$ , $CE_2$ , and $CE_3$ are sampled active. $A_{[1:0]}$ are fed to the two-bit counter.
$\overline{BW}_{[A:B]}$	93,94	Input- Synchronous	<b>Byte Write Select Inputs, active LOW.</b> Qualified with $\overline{BWE}$ to conduct byte writes to the SRAM. Sampled on the rising edge of CLK.
$\overline{GW}$	88	Input- Synchronous	<b>Global Write Enable Input, active LOW.</b> When asserted LOW on the rising edge of CLK, a global write is conducted (ALL bytes are written, regardless of the values on $\overline{BW}_{[A:B]}$ and BWE).
$\overline{BWE}$	87	Input- Synchronous	<b>Byte Write Enable Input, active LOW.</b> Sampled on the rising edge of CLK. This signal must be asserted LOW to conduct a byte write.
CLK	89	Input- Clock	<b>Clock Input.</b> Used to capture all synchronous inputs to the device. Also used to increment the burst counter when $\overline{ADV}$ is asserted LOW, during a burst operation.
$\overline{CE}_1$	98	Input- Synchronous	<b>Chip Enable 1 Input, active LOW.</b> Sampled on the rising edge of CLK. Used in conjunction with $CE_2$ and $\overline{CE}_3$ to select/deselect the device. $\overline{ADSP}$ is ignored if $\overline{CE}_1$ is HIGH.
$CE_2$	97	Input- Synchronous	<b>Chip Enable 2 Input, active HIGH.</b> Sampled on the rising edge of CLK. Used in conjunction with $\overline{CE}_1$ and $CE_3$ to select/deselect the device.
$\overline{CE}_3$	92	Input- Synchronous	<b>Chip Enable 3 Input, active LOW.</b> Sampled on the rising edge of CLK. Used in conjunction with $\overline{CE}_1$ and $CE_2$ to select/deselect the device.
$\overline{OE}$	86	Input- Asynchronous	<b>Output Enable, asynchronous input, active LOW.</b> Controls the direction of the I/O pins. When LOW, the I/O pins behave as outputs. When deasserted HIGH, I/O pins are three-stated, and act as input data pins. $\overline{OE}$ is masked during the first clock of a read cycle when emerging from a deselected state.
$\overline{ADV}$	83	Input- Synchronous	<b>Advance Input signal, sampled on the rising edge of CLK, active LOW.</b> When asserted, it automatically increments the address in a burst cycle.
$\overline{ADSP}$	84	Input- Synchronous	<b>Address Strobe from Processor, sampled on the rising edge of CLK, active LOW.</b> When asserted LOW, addresses presented to the device are captured in the address registers. $A_{[1:0]}$ are also loaded into the burst counter. When $\overline{ADSP}$ and $\overline{ADSC}$ are both asserted, only $\overline{ADSP}$ is recognized. $\overline{ADSP}$ is ignored when $\overline{CE}_1$ is deasserted HIGH.
$\overline{ADSC}$	85	Input- Synchronous	<b>Address Strobe from Controller, sampled on the rising edge of CLK, active LOW.</b> When asserted LOW, addresses presented to the device are captured in the address registers. $A_{[1:0]}$ are also loaded into the burst counter. When $\overline{ADSP}$ and $\overline{ADSC}$ are both asserted, only $\overline{ADSP}$ is recognized.
ZZ	64	Input- Asynchronous	<b>ZZ "sleep" Input, active HIGH.</b> When asserted HIGH places the device in a non-time-critical "sleep" condition with data integrity preserved. For normal operation, this pin has to be LOW or left floating. ZZ pin has an internal pull-down.
DQs DQP <sub>[A:B]</sub>	8,9,12,13, 18,19,22, 23,24,58, 59,62,63, 68,69,72, 73,74	I/O- Synchronous	<b>Bidirectional Data I/O lines.</b> As inputs, they feed into an on-chip data register that is triggered by the rising edge of CLK. As outputs, they deliver the data contained in the memory location specified by the addresses presented during the previous clock rise of the read cycle. The direction of the pins is controlled by $\overline{OE}$ . When $\overline{OE}$ is asserted LOW, the pins behave as outputs. When HIGH, DQs and DQP <sub>[A:B]</sub> are placed in a three-state condition.
V <sub>DD</sub>	15,41,65, 91	Power Supply	<b>Power supply inputs to the core of the device.</b>
V <sub>SS</sub>	17,40,67, 90	Ground	<b>Ground for the core of the device.</b>
V <sub>DDQ</sub>	4,11,20,27, 54,61,70, 77	I/O Power Supply	<b>Power supply for the I/O circuitry.</b>
V <sub>SSQ</sub>	5,10,21,26, 55,60,71, 76	I/O Ground	<b>Ground for the I/O circuitry.</b>

**Pin Descriptions** (continued)

Pin	TQFP	Type	Description
MODE	31	Input-Static	<b>Selects Burst Order.</b> When tied to GND selects linear burst sequence. When tied to $V_{DD}$ or left floating selects interleaved burst sequence. This is a strap pin and should remain static during device operation. Mode Pin has an internal pull-up.
NC	1,2,3,6,7,14,16,25,28,29,30,38,39,42,43,49,50,51,52,53,56,57,66,75,78,79,95,96		<b>No Connects.</b> Not internally connected to the die.

**Functional Overview**

All synchronous inputs pass through input registers controlled by the rising edge of the clock. All data outputs pass through output registers controlled by the rising edge of the clock.

The CY7C1298F supports secondary cache in systems utilizing either a linear or interleaved burst sequence. The interleaved burst order supports Pentium and i486™ processors. The linear burst sequence is suited for processors that utilize a linear burst sequence. The burst order is user selectable, and is determined by sampling the MODE input. Accesses can be initiated with either the Processor Address Strobe (ADSP) or the Controller Address Strobe (ADSC). Address advancement through the burst sequence is controlled by the ADV input. A two-bit on-chip wraparound burst counter captures the first address in a burst sequence and automatically increments the address for the rest of the burst access.

Byte write operations are qualified with the Byte Write Enable ( $\overline{BWE}$ ) and Byte Write Select ( $\overline{BW}_{[A:B]}$ ) inputs. A Global Write Enable ( $\overline{GW}$ ) overrides all byte write inputs and writes data to all four bytes. All writes are simplified with on-chip synchronous self-timed write circuitry.

Synchronous Chip Selects  $\overline{CE}_1$ ,  $CE_2$ ,  $\overline{CE}_3$  and an asynchronous Output Enable ( $\overline{OE}$ ) provide for easy bank selection and output three-state control. ADSP is ignored if  $CE_1$  is HIGH.

**Single Read Accesses**

This access is initiated when the following conditions are satisfied at clock rise: (1) ADSP or ADSC is asserted LOW, (2) chip selects are all asserted active, and (3) the write signals (GW, BWE) are all deasserted HIGH. ADSP is ignored if  $CE_1$  is HIGH. The address presented to the address inputs is stored into the address advancement logic and the Address Register while being presented to the memory core. The corresponding data is allowed to propagate to the input of the Output Registers. At the rising edge of the next clock the data is allowed to propagate through the output register and onto the data bus within  $t_{co}$  if OE is active LOW. The only exception occurs when the SRAM is emerging from a deselected state to a selected state, its outputs are always three-stated during the first cycle of the access. After the first cycle of the access, the outputs are controlled by the  $\overline{OE}$  signal. Consecutive single read cycles are supported.

The CY7C1298F is a double-cycle deselect part. Once the SRAM is deselected at clock rise by the chip select and either ADSP or ADSC signals, its output will three-state immediately after the next clock rise.

**Single Write Accesses Initiated by  $\overline{ADSP}$** 

This access is initiated when both of the following conditions are satisfied at clock rise: (1)  $\overline{ADSP}$  is asserted LOW, and (2) chip select is asserted active. The address presented is loaded into the address register and the address advancement logic while being delivered to the memory core. The write signals (GW, BWE, and  $\overline{BW}_{[A:B]}$ ) and ADV inputs are ignored during this first cycle.

ADSP triggered write accesses require two clock cycles to complete. If GW is asserted LOW on the second clock rise, the data presented to the DQx inputs is written into the corresponding address location in the memory core. If GW is HIGH, then the write operation is controlled by BWE and  $\overline{BW}_{[A:B]}$  signals. The CY7C1298F provides byte write capability that is described in the Write Cycle Description table. Asserting the Byte Write Enable input (BWE) with the selected Byte Write input will selectively write to only the desired bytes. Bytes not selected during a byte write operation will remain unaltered. A synchronous self-timed write mechanism has been provided to simplify the write operations.

Because the CY7C1298F is a common I/O device, the Output Enable ( $\overline{OE}$ ) must be deasserted HIGH before presenting data to the DQ inputs. Doing so will three-state the output drivers. As a safety precaution, DQ are automatically three-stated whenever a write cycle is detected, regardless of the state of OE.

**Single Write Accesses Initiated by  $\overline{ADSC}$** 

ADSC write accesses are initiated when the following conditions are satisfied: (1) ADSC is asserted LOW, (2) ADSP is deasserted HIGH, (3) chip select is asserted active, and (4) the appropriate combination of the write inputs (GW, BWE, and  $\overline{BW}_{[A:B]}$ ) are asserted active to conduct a write to the desired byte(s). ADSC triggered write accesses require a single clock cycle to complete. The address presented is loaded into the address register and the address advancement logic while being delivered to the memory core. The ADV input is ignored during this cycle. If a global write is conducted, the data presented to the DQx is written into the corresponding address location in the memory core. If a byte write is conducted, only the selected bytes are written. Bytes not selected during a byte write operation will remain unaltered. A synchronous self-timed write mechanism has been provided to simplify the write operations.



Because the CY7C1298F is a common I/O device, the Output Enable ( $\overline{OE}$ ) must be deasserted HIGH before presenting data to the  $DQ_x$  inputs. Doing so will three-state the output drivers. As a safety precaution,  $DQ_x$  are automatically three-stated whenever a write cycle is detected, regardless of the state of  $\overline{OE}$ .

### Burst Sequences

The CY7C1298F provides a two-bit wraparound counter, fed by  $A_{[1:0]}$ , that implements either an interleaved or linear burst sequence. The interleaved burst sequence is designed specifically to support Intel Pentium applications. The linear burst sequence is designed to support processors that follow a linear burst sequence. The burst sequence is user selectable through the MODE input. Both read and write burst operations are supported

Asserting  $\overline{ADV}$  LOW at clock rise will automatically increment the burst counter to the next address in the burst sequence. Both read and write burst operations are supported.

### Sleep Mode

The ZZ input pin is an asynchronous input. Asserting ZZ places the SRAM in a power conservation “sleep” mode. Two clock cycles are required to enter into or exit from this “sleep” mode. While in this mode, data integrity is guaranteed. Accesses pending when entering the “sleep” mode are not

### Truth Table [2,3, 4, 5, 6]

Operation	Address Used	$\overline{CE}_1$	$\overline{CE}_3$	$CE_2$	ZZ	$\overline{ADSP}$	$\overline{ADSC}$	$\overline{ADV}$	$\overline{WRITE}$	$\overline{OE}$	CLK	DQ
Deselected Cycle, Power-down	None	H	X	X	L	X	L	X	X	X	L-H	three-state
Deselected Cycle, Power-down	None	L	X	L	L	L	X	X	X	X	L-H	three-state
Deselected Cycle, Power-down	None	L	H	X	L	L	X	X	X	X	L-H	three-state
Deselected Cycle, Power-down	None	L	X	L	L	H	L	X	X	X	L-H	three-state
Deselected Cycle, Power-down	None	L	H	X	L	H	L	X	X	X	L-H	three-state
ZZ Mode, Power-Down	None	X	X	X	H	X	X	X	X	X	X	three-state
Read Cycle, Begin Burst	External	L	L	H	L	L	X	X	X	L	L-H	Q
Read Cycle, Begin Burst	External	L	L	H	L	L	X	X	X	H	L-H	three-state
Write Cycle, Begin Burst	External	L	L	H	L	H	L	X	L	X	L-H	D
Read Cycle, Begin Burst	External	L	L	H	L	H	L	X	H	L	L-H	Q
Read Cycle, Begin Burst	External	L	L	H	L	H	L	X	H	H	L-H	three-state
Read Cycle, Continue Burst	Next	X	X	X	L	H	H	L	H	L	L-H	Q
Read Cycle, Continue Burst	Next	X	X	X	L	H	H	L	H	H	L-H	three-state
Read Cycle, Continue Burst	Next	H	X	X	L	X	H	L	H	L	L-H	Q
Read Cycle, Continue Burst	Next	H	X	X	L	X	H	L	H	H	L-H	three-state
Write Cycle, Continue Burst	Next	X	X	X	L	H	H	L	L	X	L-H	D
Write Cycle, Continue Burst	Next	H	X	X	L	X	H	L	L	X	L-H	D

**Notes:**

- X = “Don’t Care.” H = Logic HIGH, L = Logic LOW.
- $\overline{WRITE} = L$  when any one or more Byte Write enable signals ( $\overline{BW}_A, \overline{BW}_B$ ) and  $\overline{BWE} = L$  or  $\overline{GW} = L$ .  $\overline{WRITE} = H$  when all Byte write enable signals ( $\overline{BW}_A, \overline{BW}_B$ ),  $\overline{BWE}$ ,  $\overline{GW} = H$ .
- The DQ pins are controlled by the current cycle and the  $\overline{OE}$  signal.  $\overline{OE}$  is asynchronous and is not sampled with the clock.
- The SRAM always initiates a read cycle when  $\overline{ADSP}$  is asserted, regardless of the state of  $\overline{GW}$ ,  $\overline{BWE}$ , or  $\overline{BW}_{[A; B]}$ . Writes may occur only on subsequent clocks after the  $\overline{ADSP}$  or with the assertion of  $\overline{ADSC}$ . As a result,  $\overline{OE}$  must be driven HIGH prior to the start of the write cycle to allow the outputs to three-state.  $\overline{OE}$  is a don’t care for the remainder of the write cycle.
- $\overline{OE}$  is asynchronous and is not sampled with the clock rise. It is masked internally during write cycles. During a read cycle all data bits are three-state when  $\overline{OE}$  is inactive or when the device is deselected, and all data bits behave as output when  $\overline{OE}$  is active (LOW).

considered valid nor is the completion of the operation guaranteed. The device must be deselected prior to entering the “sleep” mode.  $\overline{CE}_s$ ,  $\overline{ADSP}$ , and  $\overline{ADSC}$  must remain inactive for the duration of  $t_{ZZREC}$  after the ZZ input returns LOW.

### Interleaved ‘Burst Address Table (MODE = Floating or $V_{DD}$ )

First Address A1, A0	Second Address A1, A0	Third Address A1, A0	Fourth Address A1, A0
00	01	10	11
01	00	11	10
10	11	00	01
11	10	01	00

### Linear Burst Address Table (MODE = GND)

First Address A1, A0	Second Address A1, A0	Third Address A1, A0	Fourth Address A1, A0
00	01	10	11
01	10	11	00
10	11	00	01
11	00	01	10

**Truth Table** (continued)<sup>[2,3, 4, 5, 6]</sup>

Operation	Address Used	$\overline{CE}_1$	$\overline{CE}_3$	$CE_2$	ZZ	$\overline{ADSP}$	$\overline{ADSC}$	$\overline{ADV}$	$\overline{WRITE}$	$\overline{OE}$	CLK	DQ
Read Cycle, Suspend Burst	Current	X	X	X	L	H	H	H	H	L	L-H	Q
Read Cycle, Suspend Burst	Current	X	X	X	L	H	H	H	H	H	L-H	three-state
Read Cycle, Suspend Burst	Current	H	X	X	L	X	H	H	H	L	L-H	Q
Read Cycle, Suspend Burst	Current	H	X	X	L	X	H	H	H	H	L-H	three-state
Write Cycle, Suspend Burst	Current	X	X	X	L	H	H	H	L	X	L-H	D
Write Cycle, Suspend Burst	Current	H	X	X	L	X	H	H	L	X	L-H	D

**Truth Table for Read/Write**<sup>[2,3]</sup>

Function	$\overline{GW}$	$\overline{BWE}$	$\overline{BW}_A$	$\overline{BW}_B$
Read	H	H	X	X
Read	H	L	H	H
Write byte A – (DQ <sub>A</sub> and DQP <sub>A</sub> )	H	L	L	H
Write byte B – (DQ <sub>B</sub> and DQP <sub>B</sub> )	H	L	H	L
Write all bytes	H	L	L	L
Write all bytes	L	X	X	X

**ZZ Mode Electrical Characteristics**

Parameter	Description	Test Conditions	Min.	Max.	Unit
$I_{DDZZ}$	Snooze mode standby current	$ZZ \geq V_{DD} - 0.2V$		40	mA
$t_{ZZS}$	Device operation to ZZ	$ZZ \geq V_{DD} - 0.2V$		$2t_{CYC}$	ns
$t_{ZZREC}$	ZZ recovery time	$ZZ \leq 0.2V$	$2t_{CYC}$		ns
$t_{ZZI}$	ZZ Active to snooze current	This parameter is sampled		$2t_{CYC}$	ns
$t_{RZZI}$	ZZ inactive to exit snooze current	This parameter is sampled	0		ns



**Maximum Ratings**

(Above which the useful life may be impaired. For user guidelines, not tested.)

- Storage Temperature ..... -65°C to +150°
- Ambient Temperature with Power Applied ..... -55°C to +125°C
- Supply Voltage on V<sub>DD</sub> Relative to GND..... -0.5V to +4.6V
- DC Voltage Applied to Outputs in three-state ..... -0.5V to V<sub>DDQ</sub> +0.5V
- DC Input Voltage ..... -0.5V to V<sub>DD</sub>+0.5V

- Current into Outputs (LOW)..... 20 mA
- Static Discharge Voltage..... > 2001V (per MIL-STD-883, Method 3015)
- Latch -up Current..... > 200 mA

**Operating Range**

Range	Ambient Temperature (T <sub>A</sub> )	V <sub>DD</sub>	V <sub>DDQ</sub>
Com'l	0°C to +70°C	3.3V -5%/+10%	3.3V -5% to V <sub>DD</sub>

**Electrical Characteristics** Over the Operating Range<sup>[7,8]</sup>

Parameter	Description	Test Conditions	Min.	Max.	Unit
V <sub>DD</sub>	Power Supply Voltage		3.135	3.6	V
V <sub>DDQ</sub>	I/O Supply Voltage		3.135	V <sub>DD</sub>	V
V <sub>OH</sub>	Output HIGH Voltage	V <sub>DDQ</sub> = 3.3V, V <sub>DD</sub> = Min., I <sub>OH</sub> = -4.0 mA	2.4		V
V <sub>OL</sub>	Output LOW Voltage	V <sub>DDQ</sub> = 3.3V, V <sub>DD</sub> = Min., I <sub>OL</sub> = 8.0 mA		0.4	V
V <sub>IH</sub>	Input HIGH Voltage <sup>[7]</sup>	V <sub>DDQ</sub> = 3.3V	2.0	V <sub>DD</sub> + 0.3V	V
V <sub>IL</sub>	Input LOW Voltage <sup>[7]</sup>	V <sub>DDQ</sub> = 3.3V	-0.3	0.8	V
I <sub>X</sub>	Input Load Current except ZZ and MODE	GND ≤ V <sub>I</sub> ≤ V <sub>DDQ</sub>	-5	5	μA
	Input Current of MODE	Input = V <sub>SS</sub>	-30		μA
		Input = V <sub>DD</sub>		5	μA
	Input Current of ZZ	Input = V <sub>SS</sub>	-5		μA
Input = V <sub>DD</sub>			30	μA	
I <sub>OZ</sub>	Output Leakage Current	GND ≤ V <sub>I</sub> ≤ V <sub>DDQ</sub> , Output Disabled	-5	5	μA
I <sub>DD</sub>	V <sub>DD</sub> Operating Supply Current	V <sub>DD</sub> = Max., I <sub>OUT</sub> = 0 mA, f = f <sub>MAX</sub> = 1/t <sub>CYC</sub>	6-ns cycle, 166 MHz	240	mA
		7.5-ns cycle, 133 MHz	225	mA	
I <sub>SB1</sub>	Automatic CS Power-down Current—TTL Inputs	V <sub>DD</sub> = Max., Device Deselected, V <sub>IN</sub> ≥ V <sub>IH</sub> or V <sub>IN</sub> ≤ V <sub>IL</sub> , f = f <sub>MAX</sub> = 1/t <sub>CYC</sub>	6-ns cycle, 166 MHz	100	mA
			7.5-ns cycle, 133 MHz	90	mA
I <sub>SB2</sub>	Automatic CS Power-down Current—CMOS Inputs	V <sub>DD</sub> = Max., Device Deselected, V <sub>IN</sub> ≤ 0.3V or V <sub>IN</sub> ≥ V <sub>DDQ</sub> - 0.3V, f = 0		40	mA
I <sub>SB3</sub>	Automatic CS Power-down Current—CMOS Inputs	V <sub>DD</sub> = Max., Device Deselected, or V <sub>IN</sub> ≤ 0.3V or V <sub>IN</sub> ≥ V <sub>DDQ</sub> - 0.3V, f = f <sub>MAX</sub> = 1/t <sub>CYC</sub>	6-ns cycle, 166 MHz	85	mA
			7.5-ns cycle, 133 MHz	75	mA
I <sub>SB4</sub>	Automatic CS Power-down Current—TTL Inputs	V <sub>DD</sub> = Max., Device Deselected, V <sub>IN</sub> ≥ V <sub>IH</sub> or V <sub>IN</sub> ≤ V <sub>IL</sub> , f = 0		45	mA

**Thermal Characteristics**<sup>[9]</sup>

Parameter	Description	Test Conditions	TQFP Package	Unit
Θ <sub>JA</sub>	Thermal Resistance (Junction to Ambient)	Test conditions follow standard test methods and procedures for measuring thermal impedance, per EIA/JESD51	41.83	°C/W
Θ <sub>JC</sub>	Thermal Resistance (Junction to case)		9.99	°C/W

**Notes:**

7. Overshoot: V<sub>IH</sub>(AC) < V<sub>DD</sub> +1.5V (Pulse width less than t<sub>CYC</sub>/2), undershoot: V<sub>IL</sub>(AC) > -2V (Pulse width less than t<sub>CYC</sub>/2).
8. Power-up: Assumes a linear ramp from 0v to V<sub>DD</sub>(min.) within 200 ms. During this time V<sub>IH</sub> ≤ V<sub>DD</sub> and V<sub>DDQ</sub> ≤ V<sub>DD</sub>.



**Capacitance<sup>[9]</sup>**

Parameter	Description	Test Conditions	Max.	Unit
$C_{IN}$	Input Capacitance	$T_A = 25^\circ\text{C}$ , $f = 1\text{ MHz}$ , $V_{DD} = 3.3\text{V}$ $V_{DDQ} = 3.3\text{V}$	5	pF
$C_{CLK}$	Clock Input Capacitance		5	pF
$C_{I/O}$	Input/Output Capacitance		5	pF

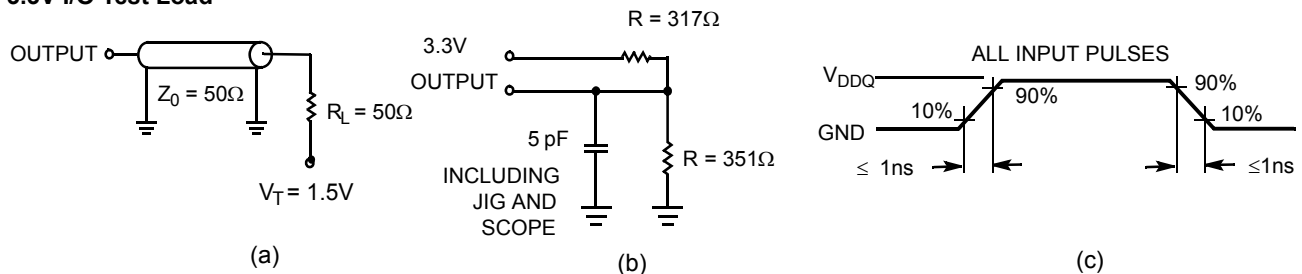
**AC Test Loads and Waveforms**
**3.3V I/O Test Load**

**Switching Characteristics Over the Operating Range<sup>[15]</sup>**

Parameter	Description	166 MHz		133 MHz		Unit
		Min.	Max.	Min.	Max.	
$t_{POWER}$	$V_{DD}$ (Typical) to the first Access <sup>[10]</sup>	1		1		ms
<b>Clock</b>						
$t_{CYC}$	Clock Cycle Time	6.0		7.5		ns
$t_{CH}$	Clock HIGH	2.5		3.0		ns
$t_{CL}$	Clock LOW	2.5		3.0		ns
<b>Output Times</b>						
$t_{CO}$	Data Output Valid After CLK Rise		3.5		4.0	ns
$t_{DOH}$	Data Output Hold After CLK Rise	2.0		2.0		ns
$t_{CLZ}$	Clock to Low-Z <sup>[11, 12, 13]</sup>	0		0		ns
$t_{CHZ}$	Clock to High-Z <sup>[11, 12, 13]</sup>		3.5		4.0	ns
$t_{OEV}$	$\overline{OE}$ LOW to Output Valid		3.5		4.5	ns
$t_{OELZ}$	$\overline{OE}$ LOW to Output Low-Z <sup>[11, 12, 13]</sup>	0		0		ns
$t_{OEZH}$	$\overline{OE}$ HIGH to Output High-Z <sup>[11, 12, 13]</sup>		3.5		4.0	ns
<b>Set-up Times</b>						
$t_{AS}$	Address Set-up Before CLK Rise	1.5		1.5		ns
$t_{ADS}$	$\overline{ADSC}$ , $\overline{ADSP}$ Set-up Before CLK Rise	1.5		1.5		ns
$t_{ADVS}$	$\overline{ADV}$ Set-up Before CLK Rise	1.5		1.5		ns
$t_{WES}$	$\overline{GW}$ , $\overline{BWE}$ , $\overline{BW}_{[A:B]}$ Set-up Before CLK Rise	1.5		1.5		ns
$t_{DS}$	Data Input Set-up Before CLK Rise	1.5		1.5		ns
$t_{CES}$	Chip Enable Set-up Before CLK Rise	1.5		1.5		ns

**Notes:**

- Tested initially and after any design or process change that may affect these parameters.
- This part has a voltage regulator internally; power is the time that the power needs to be supplied above  $V_{DD}$  minimum initially before a read or write operation can be initiated.
- $t_{CHZ}$ ,  $t_{CLZ}$ ,  $t_{OELZ}$ , and  $t_{OEZH}$  are specified with AC test conditions shown in part (b) of AC Test Loads. Transition is measured  $\pm 200\text{ mV}$  from steady-state voltage.
- At any given voltage and temperature,  $t_{OEZH}$  is less than  $t_{OELZ}$  and  $t_{CHZ}$  is less than  $t_{CLZ}$  to eliminate bus contention between SRAMs when sharing the same data bus. These specifications do not imply a bus contention condition, but reflect parameters guaranteed over worst case user conditions. Device is designed to achieve High-Z prior to Low-Z under the same system conditions.
- This parameter is sampled and not 100% tested.
- Timing reference level is 1.5V when  $V_{DDQ} = 3.3\text{V}$ .
- Test conditions shown in (a) of AC Test Loads unless otherwise noted.

**Switching Characteristics** Over the Operating Range (continued)<sup>[15]</sup>

Parameter	Description	166 MHz		133 MHz		Unit
		Min.	Max.	Min.	Max.	
<b>Hold Times</b>						
$t_{AH}$	Address Hold After CLK Rise	0.5		0.5		ns
$t_{ADH}$	$\overline{ADSP}$ , $\overline{ADSC}$ Hold After CLK Rise	0.5		0.5		ns
$t_{ADVH}$	$\overline{ADV}$ Hold After CLK Rise	0.5		0.5		ns
$t_{WEH}$	$\overline{GW}$ , $\overline{BWE}$ , $\overline{BW}_{[A:B]}$ Hold After CLK Rise	0.5		0.5		ns
$t_{DH}$	Data Input Hold After CLK Rise	0.5		0.5		ns
$t_{CEH}$	Chip Enable Hold After CLK Rise	0.5		0.5		ns

**Switching Waveforms**

**Read Timing<sup>[16]</sup>**

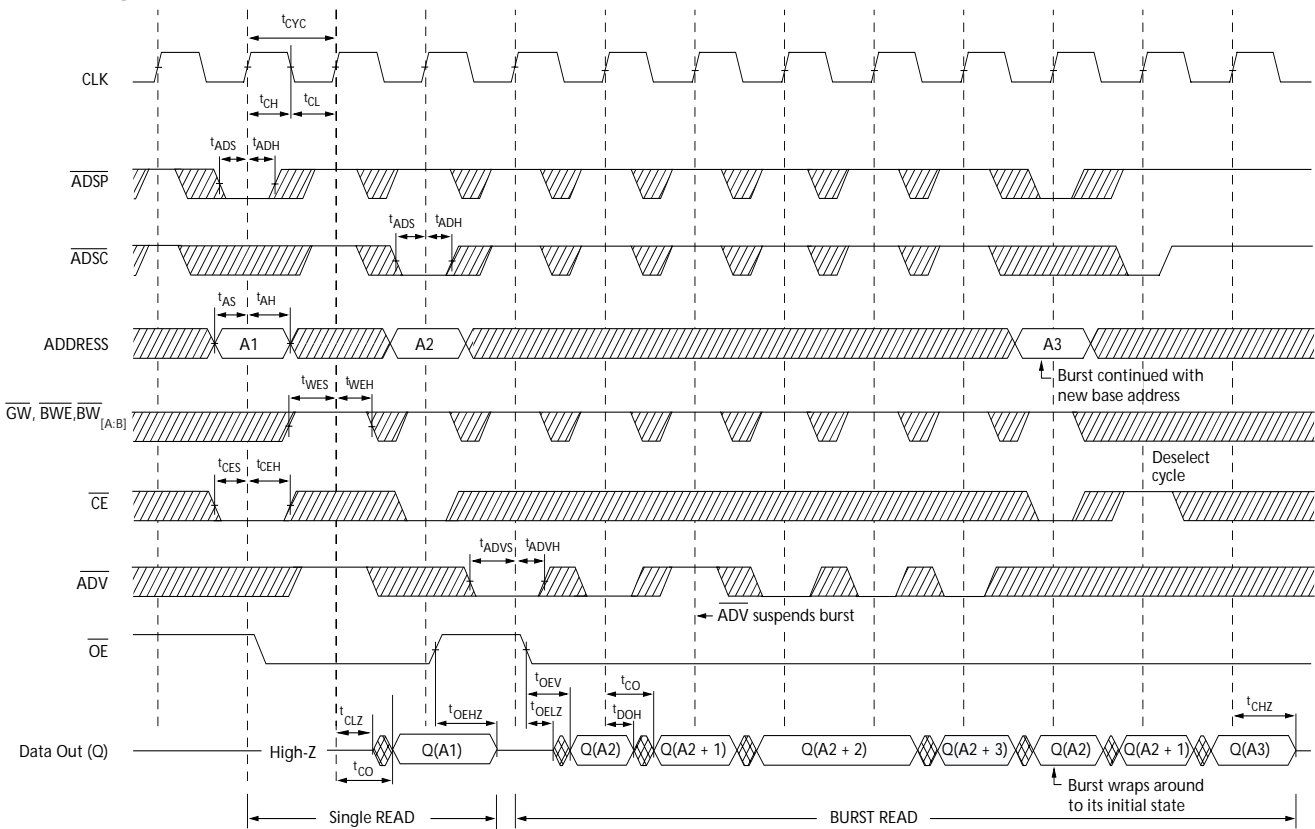

 DON'T CARE     
  UNDEFINED

**Note:**  
 16. On this diagram, when  $\overline{CE}$  is LOW,  $\overline{CE}_1$  is LOW,  $\overline{CE}_2$  is HIGH and  $\overline{CE}_3$  is LOW. When  $\overline{CE}$  is HIGH,  $\overline{CE}_1$  is HIGH or  $\overline{CE}_2$  is LOW or  $\overline{CE}_3$  is HIGH.

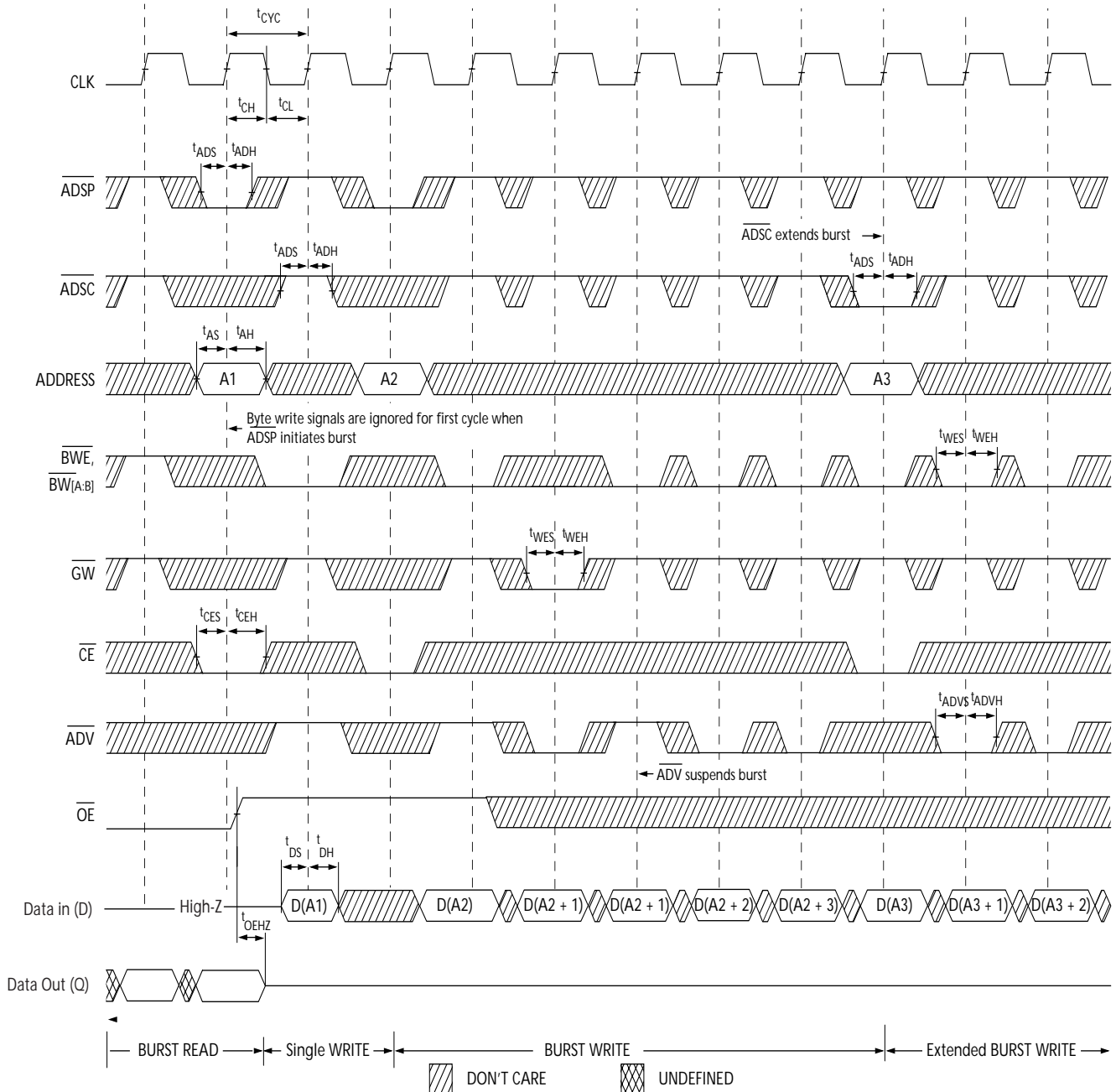
**Switching Waveforms (continued)**
**Write Timing<sup>[16,17]</sup>**

**Note:**

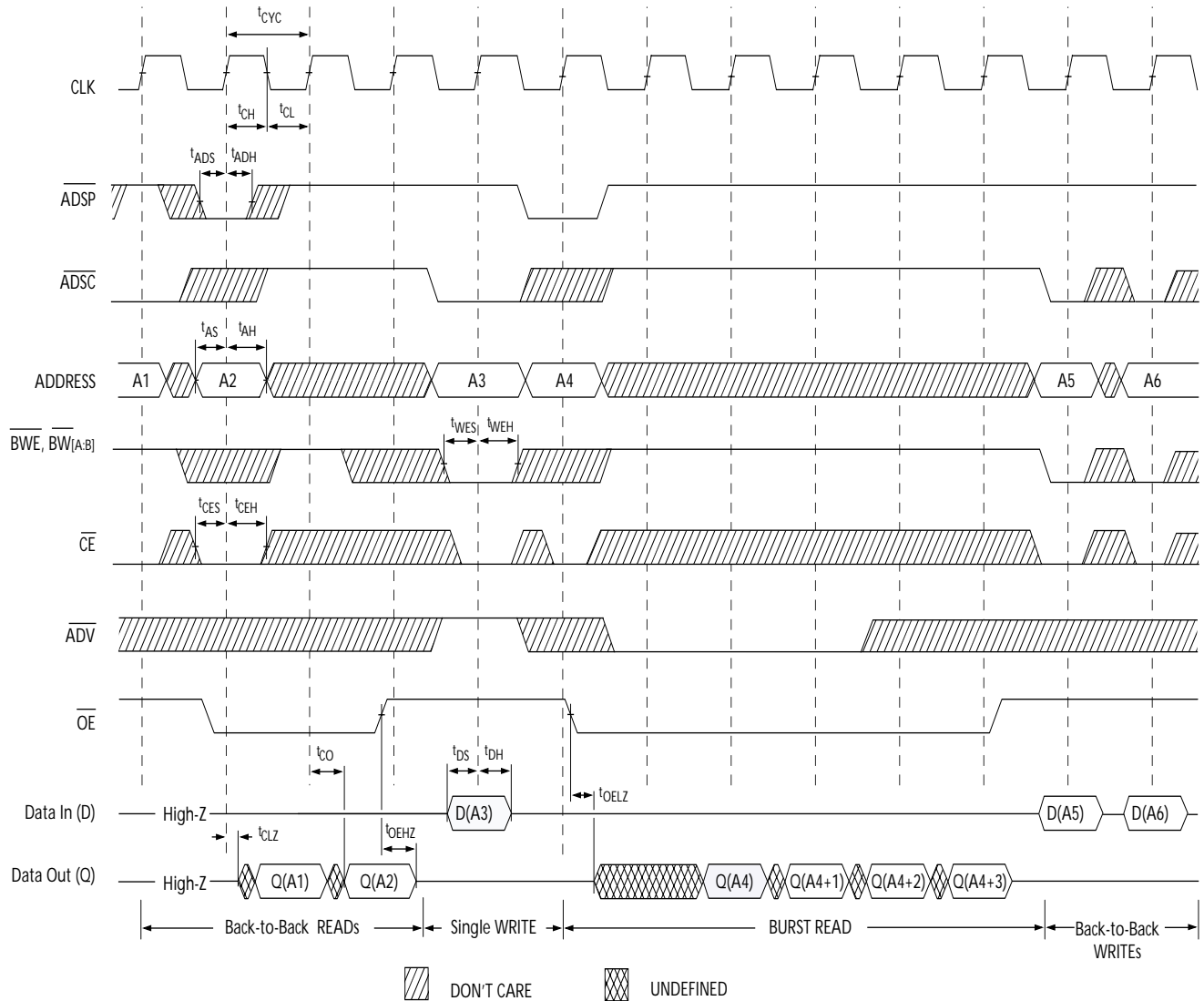
17. Full width write can be initiated by either  $\overline{GW}$  LOW; or by  $\overline{GW}$  HIGH,  $\overline{BWE}$  LOW and  $\overline{BW}_{[A:B]}$  LOW.

**Switching Waveforms (continued)**
**Read/Write Timing<sup>[16,18,19]</sup>**

**Notes:**

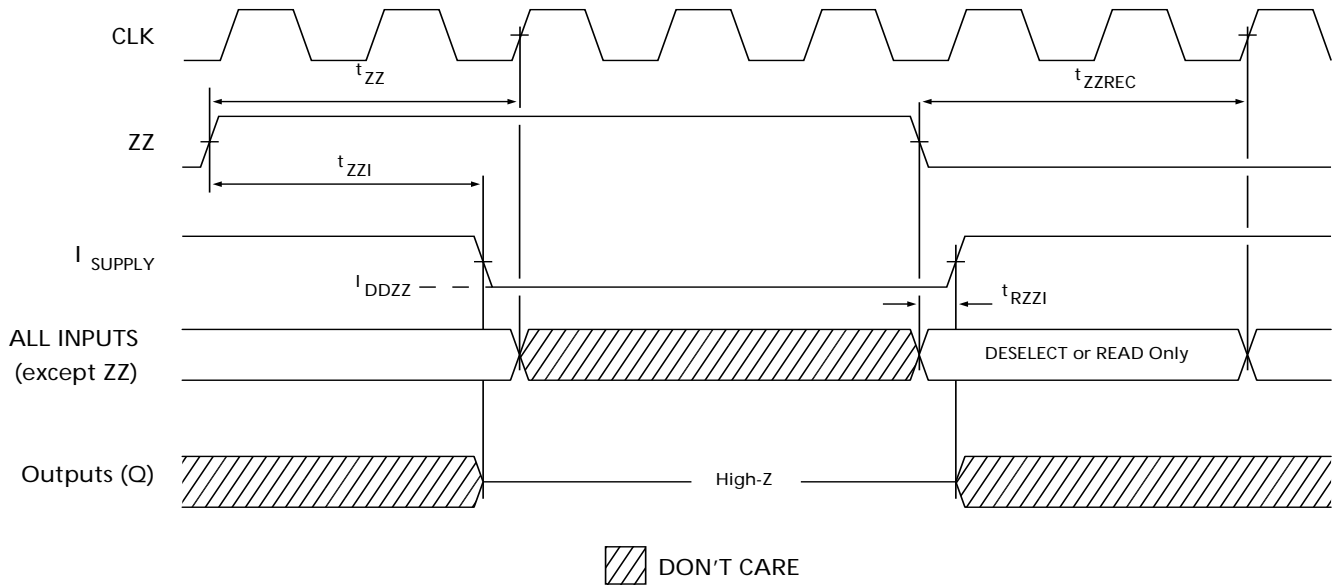
18. The data bus (Q) remains in High-Z following a WRITE cycle, unless a new read access initiated by  $\overline{\text{ADSP}}$  or  $\overline{\text{ADSP}}$ .

19.  $\overline{\text{GW}}$  is HIGH.

**Switching Waveforms (continued)**
**ZZ Mode Timing** <sup>[20,21]</sup>

**Ordering Information**

Speed <sup>[22]</sup> (MHz)	Ordering Code	Package Name	Package Type	Operating Range
133	CY7C1298F-133AC	A101	100-Lead 14 x 20 x 1.4 mm Thin Quad Flat Pack	Commercial

Shaded areas contain advance information. Please contact your local Cypress sales representative for availability of this part. Please contact your local Cypress Sales representative for availability of 166-MHz speed grade option.

**Note:**

20. Device must be deselected when entering ZZ mode. See truth table for all possible signal conditions to deselect the device.

21. I/Os are in High-Z when exiting ZZ sleep mode.

22. Please contact your local Cypress sales representative for availability of 166-MHz speed grade option

Package Diagram

100-pin Thin Plastic Quad Flatpack (14 x 20 x 1.4 mm) A101

DIMENSIONS ARE IN MILLIMETERS.

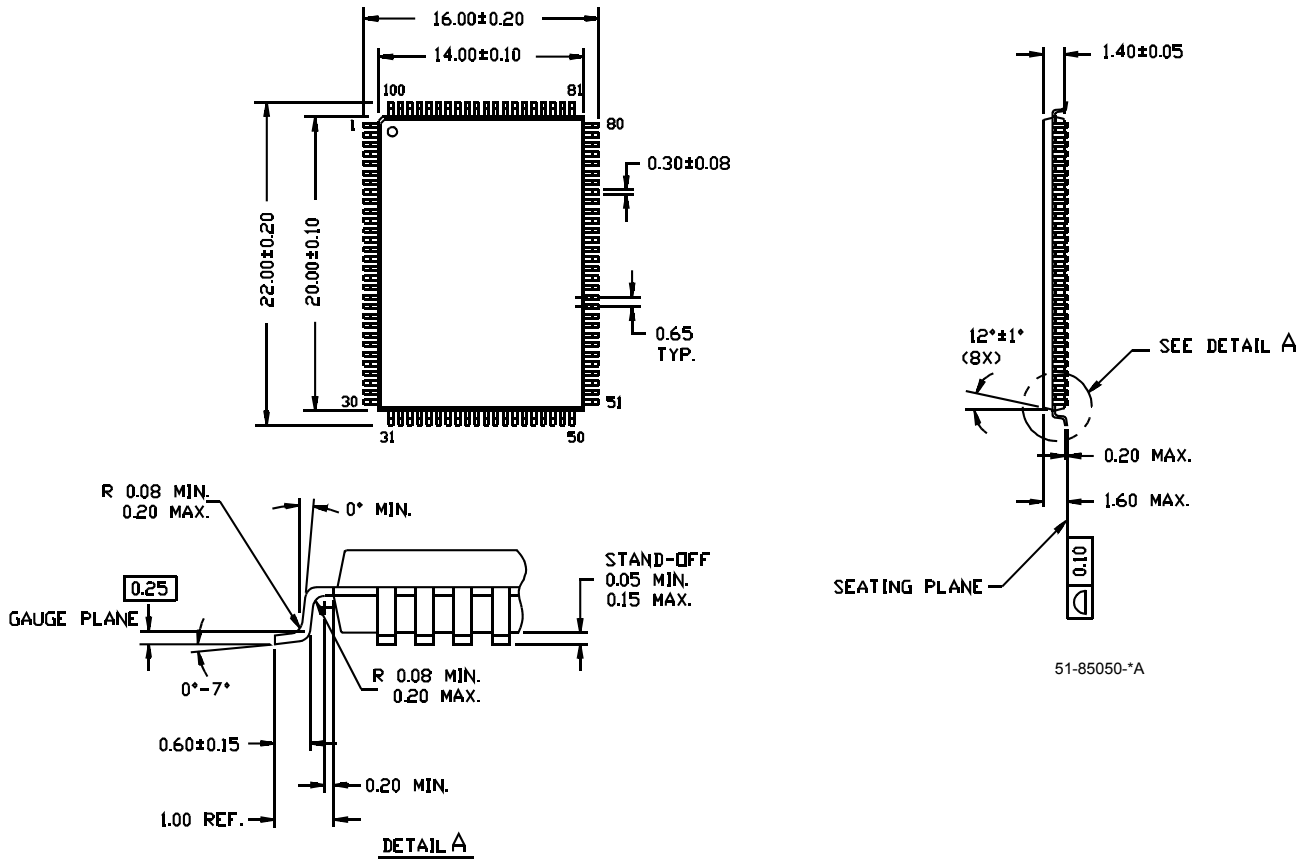

Intel and Pentium are registered trademarks, and i486 is a trademark, of Intel Corporation. PowerPC is a registered trademark of IBM. All product and company names mentioned in this document are the trademarks of their respective holders.



**Document History Page**

<b>Document Title: CY7C1298F 1-Mb 64K x 18 Pipelined DCD Sync SRAM</b>				
<b>Document Number: 38-05417</b>				
<b>REV.</b>	<b>ECN NO.</b>	<b>Issue Date</b>	<b>Orig. of Change</b>	<b>Description of Change</b>
**	130301	12/30/03	NJY	New Data Sheet
*A	213321	See ECN	VBL	Updated Ordering Info section: shaded part number, added explanation Shaded Selection Guide, Characteristics section