

TOSHIBA TA78L005,006,007,075,008,009,10,12,13,15,18,20,24AP

TOSHIBA BIPOLAR LINEAR INTEGRATED CIRCUIT SILICON MONOLITHIC

TA78L005AP, TA78L006AP, TA78L007AP, TA78L075AP
 TA78L008AP, TA78L009AP, TA78L010AP, TA78L012AP
 TA78L132AP, TA78L015AP, TA78L018AP, TA78L020AP, TA78L024AP

THREE TERMINAL POSITIVE REGULATORS

5V, 6V, 7V, 7.5V, 8V, 9V, 10V, 12V, 13.2V, 15V, 18V, 20V, 24V

FEATURES

- Suitable for TTL, C²MOS Power Supply
- Internal Short-Circuit Current Limiting
- Internal Thermal Overload Protection
- Maximum Output Current of 150mA (T_j = 25°C)
- Available in the Plastic TO-92MOD Package

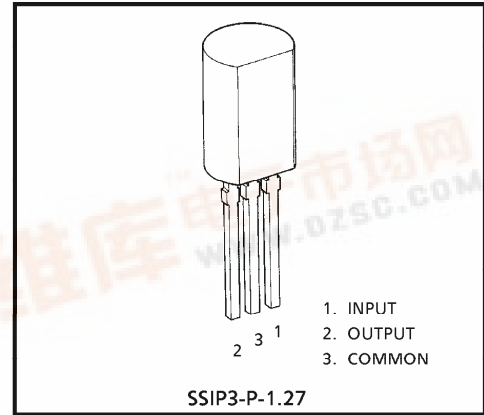

Weight : 0.36g (Typ.)

EQUIVALENT CIRCUIT

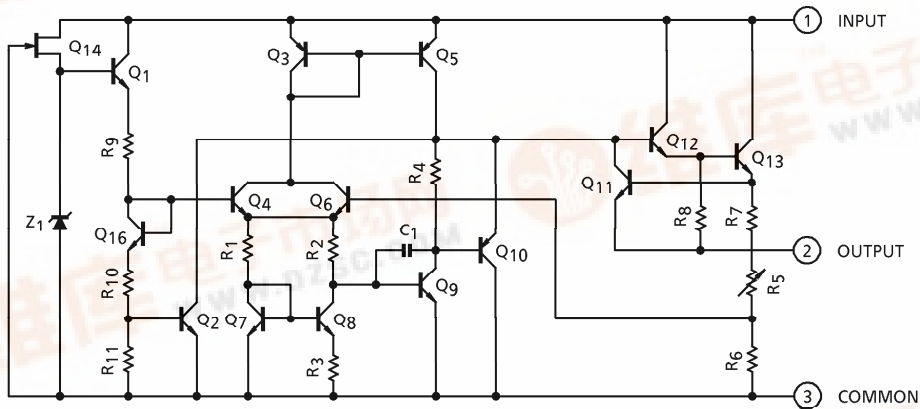

961001EBA2

- TOSHIBA is continually working to improve the quality and the reliability of its products. Nevertheless, semiconductor devices in general can malfunction or fail due to their inherent electrical sensitivity and vulnerability to physical stress. It is the responsibility of the buyer, when utilizing TOSHIBA products, to observe standards of safety, and to avoid situations in which a malfunction or failure of a TOSHIBA product could cause loss of human life, bodily injury or damage to property. In developing your designs, please ensure that TOSHIBA products are used within specified operating ranges as set forth in the most recent products specifications. Also, please keep in mind the precautions and conditions set forth in the TOSHIBA Semiconductor Reliability Handbook.
- The products described in this document are subject to foreign exchange and foreign trade control laws.
- The information contained herein is presented only as a guide for the applications of our products. No responsibility is assumed by TOSHIBA CORPORATION for any infringements of intellectual property or other rights of the third parties which may result from its use. No license is granted by implication or otherwise under any intellectual property or other rights of TOSHIBA CORPORATION or others.
- The information contained herein is subject to change without notice.



MAXIMUM RATINGS (Ta = 25°C)

CHARACTERISTIC		SYMBOL	RATING	UNIT
Input Voltage	TA78L005AP	V _{IN}	35	V
	TA78L006AP			
	TA78L007AP			
	TA78L075AP			
	TA78L008AP			
	TA78L009AP			
	TA78L010AP			
	TA78L012AP			
	TA78L132AP			
	TA78L015AP			
	TA78L018AP		40	
	TA78L020AP			
	TA78L024AP			
Power Dissipation	(Ta = 25°C)	P _D	800	mW
Operating Temperature		T _{opr}	- 30~75	°C
Storage Temperature		T _{stg}	- 55~150	°C
Operating Junction Temperature		T _j	- 30~150	°C
Thermal Resistance		R _{th(j-a)}	156	°C/W

TA78L005AP

ELECTRICAL CHARACTERISTICS

(Unless otherwise specified, $V_{IN} = 10V$, $I_{OUT} = 40mA$, $C_{IN} = 0.33\mu F$, $C_{OUT} = 0.1\mu F$, $0^{\circ}C \leq T_j \leq 125^{\circ}C$)

CHARACTERISTIC	SYMBOL	TEST CIR-CUIT	TEST CONDITION	MIN.	TYP.	MAX.	UNIT
Output Voltage	V_{OUT}	1	$T_j = 25^{\circ}C$	4.8	5.0	5.2	V
Line Regulation	Reg.line	1	$T_j = 25^{\circ}C$	—	55	150	mV
				—	45	100	
Load Regulation	Reg.load	1	$T_j = 25^{\circ}C$	—	11	60	mV
				—	5.0	30	
Output Voltage	V_{OUT}	1	$T_j = 25^{\circ}C$	4.75	—	5.25	V
				4.75	—	5.25	
				—	—	—	
Quiescent Current	I_B	1	$T_j = 25^{\circ}C$	—	3.1	6.0	mA
			$T_j = 125^{\circ}C$	—	—	5.5	
Quiescent Current Change	ΔI_B	1	$8.0V \leq V_{IN} \leq 20V$	—	—	1.5	mA
			$1.0mA \leq I_{OUT} \leq 40mA$	—	—	0.1	
Output Noise Voltage	V_{NO}	2	$T_a = 25^{\circ}C$, $10Hz \leq f \leq 100kHz$	—	40	—	μV_{rms}
Long Term Stability	$\Delta V_{OUT} / \Delta t$	1	—	—	12	—	mV / 1.0kh
Ripple Rejection	R.R.	3	$f = 120Hz$, $8.0V \leq V_{IN} \leq 18V$, $T_j = 25^{\circ}C$	41	49	—	dB
Dropout Voltage	$ V_{IN} - V_{OUT} $	1	$T_j = 25^{\circ}C$, $I_{OUT} = 150mA$	—	1.7	—	V
Average Temperature Coefficient of Output Voltage	T_{CVO}	1	$I_{OUT} = 5mA$	—	-0.6	—	mV / $^{\circ}C$

TA78L006AP

ELECTRICAL CHARACTERISTICS

(Unless otherwise specified, $V_{IN} = 11V$, $I_{OUT} = 40mA$, $C_{IN} = 0.33\mu F$, $C_{OUT} = 0.1\mu F$, $0^{\circ}C \leq T_j \leq 125^{\circ}C$)

CHARACTERISTIC	SYMBOL	TEST CIR-CUIT	TEST CONDITION	MIN.	TYP.	MAX.	UNIT	
Output Voltage	V_{OUT}	1	$T_j = 25^{\circ}C$	5.76	6.0	6.24	V	
Line Regulation	Reg.line	1	$T_j = 25^{\circ}C$	$8.1V \leq V_{IN} \leq 21V$	—	50	150	mV
				$9.0V \leq V_{IN} \leq 21V$	—	45	110	
Load Regulation	Reg.load	1	$T_j = 25^{\circ}C$	$1.0mA \leq I_{OUT} \leq 100mA$	—	12	70	mV
				$1.0mA \leq I_{OUT} \leq 40mA$	—	5.5	35	
Output Voltage	V_{OUT}	1	$T_j = 25^{\circ}C$	$8.1V \leq V_{IN} \leq 21V$	5.7	—	6.3	V
				$1.0mA \leq I_{OUT} \leq 40mA$	5.7	—	6.3	
				$1.0mA \leq I_{OUT} \leq 70mA$	5.7	—	6.3	
Quiescent Current	I_B	1	$T_j = 25^{\circ}C$	—	3.1	6.0	mA	
			$T_j = 125^{\circ}C$	—	—	5.5		
Quiescent Current Change	ΔI_B	1	$9.0V \leq V_{IN} \leq 20V$	—	—	1.5	mA	
			$1.0mA \leq I_{OUT} \leq 40mA$	—	—	0.1		
Output Noise Voltage	V_{NO}	2	$T_a = 25^{\circ}C$, $10Hz \leq f \leq 100kHz$	—	40	—	μV_{rms}	
Long Term Stability	$\Delta V_{OUT} / \Delta t$	1	—	—	14	—	mV / 1.0kh	
Ripple Rejection	R.R.	3	$f = 120Hz$, $9.0V \leq V_{IN} \leq 19V$, $T_j = 25^{\circ}C$	39	47	—	dB	
Dropout Voltage	$ V_{IN} - V_{OUT} $	1	$T_j = 25^{\circ}C$, $I_{OUT} = 150mA$	—	1.7	—	V	
Average Temperature Coefficient of Output Voltage	T_{CVO}	1	$I_{OUT} = 5mA$	—	-0.7	—	mV / $^{\circ}C$	

TA78L007AP

ELECTRICAL CHARACTERISTICS

(Unless otherwise specified, $V_{IN} = 12V$, $I_{OUT} = 40mA$, $C_{IN} = 0.33\mu F$, $C_{OUT} = 0.1\mu F$, $0^\circ C \leq T_j \leq 125^\circ C$)

CHARACTERISTIC	SYMBOL	TEST CIR-CUIT	TEST CONDITION	MIN.	TYP.	MAX.	UNIT	
Output Voltage	V_{OUT}	1	$T_j = 25^\circ C$	6.72	7.0	7.28	V	
Line Regulation	Reg.line	1	$T_j = 25^\circ C$	—	50	160	mV	
				$9.2V \leq V_{IN} \leq 22V$	—	45		115
Load Regulation	Reg.load	1	$T_j = 25^\circ C$	$1.0mA \leq I_{OUT} \leq 100mA$	—	13	75	mV
				$1.0mA \leq I_{OUT} \leq 40mA$	—	6.0	40	
Output Voltage	V_{OUT}	1	$T_j = 25^\circ C$	$9.2V \leq V_{IN} \leq 22V$	6.65	—	7.35	V
				$1.0mA \leq I_{OUT} \leq 40mA$	6.65	—	7.35	
				$1.0mA \leq I_{OUT} \leq 70mA$	6.65	—	7.35	
Quiescent Current	I_B	1	$T_j = 25^\circ C$	—	3.1	6.5	mA	
			$T_j = 125^\circ C$	—	—	6.0		
Quiescent Current Change	ΔI_B	1	$10V \leq V_{IN} \leq 22V$	—	—	1.5	mA	
			$1.0mA \leq I_{OUT} \leq 40mA$	—	—	0.1		
Output Noise Voltage	V_{NO}	2	$T_a = 25^\circ C$, $10Hz \leq f \leq 100kHz$	—	50	—	μV_{rms}	
Long Term Stability	$\Delta V_{OUT} / \Delta t$	1	—	—	17	—	mV / 1.0kh	
Ripple Rejection	R.R.	3	$f = 120Hz$, $10V \leq V_{IN} \leq 20V$, $T_j = 25^\circ C$	37	46	—	dB	
Dropout Voltage	$ V_{IN} - V_{OUT} $	1	$T_j = 25^\circ C$, $I_{OUT} = 150mA$	—	1.7	—	V	
Average Temperature Coefficient of Output Voltage	T_{CVO}	1	$I_{OUT} = 5mA$	—	-0.75	—	mV / $^\circ C$	

TA78L075AP

ELECTRICAL CHARACTERISTICS

(Unless otherwise specified, $V_{IN} = 13V$, $I_{OUT} = 40mA$, $C_{IN} = 0.33\mu F$, $C_{OUT} = 0.1\mu F$, $0^\circ C \leq T_j \leq 125^\circ C$)

CHARACTERISTIC	SYMBOL	TEST CIR-CUIT	TEST CONDITION	MIN.	TYP.	MAX.	UNIT	
Output Voltage	V_{OUT}	1	$T_j = 25^\circ C$	7.21	7.5	7.79	V	
Line Regulation	Reg.line	1	$T_j = 25^\circ C$	$9.8V \leq V_{IN} \leq 23V$	—	40	170	mV
				$10.5V \leq V_{IN} \leq 23V$	—	40	120	
Load Regulation	Reg.load	1	$T_j = 25^\circ C$	$1.0mA \leq I_{OUT} \leq 100mA$	—	14	80	mV
				$1.0mA \leq I_{OUT} \leq 40mA$	—	6.5	40	
Output Voltage	V_{OUT}	1	$T_j = 25^\circ C$	$9.8V \leq V_{IN} \leq 23V,$ $1.0mA \leq I_{OUT} \leq 40mA$	7.125	—	7.875	V
				$1.0mA \leq I_{OUT} \leq 70mA$	7.125	—	7.875	
Quiescent Current	I_B	1	$T_j = 25^\circ C$	—	3.1	6.5	mA	
			$T_j = 125^\circ C$	—	—	6.0		
Quiescent Current Change	ΔI_B	1	$10.5V \leq V_{IN} \leq 23V$	—	—	1.5	mA	
			$1.0mA \leq I_{OUT} \leq 40mA$	—	—	0.1		
Output Noise Voltage	V_{NO}	2	$T_a = 25^\circ C, 10Hz \leq f \leq 100kHz$	—	60	—	μV_{rms}	
Long Term Stability	$\Delta V_{OUT} / \Delta t$	1	—	—	19	—	mV / 1.0kh	
Ripple Rejection	R.R.	3	$f = 120Hz,$ $11V \leq V_{IN} \leq 21V, T_j = 25^\circ C$	37	45	—	dB	
Dropout Voltage	$ V_{IN} - V_{OUT} $	1	$T_j = 25^\circ C, I_{OUT} = 150mA$	—	1.7	—	V	
Average Temperature Coefficient of Output Voltage	T_{CVO}	1	$I_{OUT} = 5mA$	—	-0.75	—	mV / $^\circ C$	

TA78L008AP

ELECTRICAL CHARACTERISTICS

(Unless otherwise specified, $V_{IN} = 14V$, $I_{OUT} = 40mA$, $C_{IN} = 0.33\mu F$, $C_{OUT} = 0.1\mu F$, $0^\circ C \leq T_j \leq 125^\circ C$)

CHARACTERISTIC	SYMBOL	TEST CIR-CUIT	TEST CONDITION	MIN.	TYP.	MAX.	UNIT	
Output Voltage	V_{OUT}	1	$T_j = 25^\circ C$	7.7	8.0	8.3	V	
Line Regulation	Reg.line	1	$T_j = 25^\circ C$	$10.5V \leq V_{IN} \leq 23V$	—	20	175	mV
				$11V \leq V_{IN} \leq 23V$	—	12	125	
Load Regulation	Reg.load	1	$T_j = 25^\circ C$	$1.0mA \leq I_{OUT} \leq 100mA$	—	15	80	mV
				$1.0mA \leq I_{OUT} \leq 40mA$	—	7.0	40	
Output Voltage	V_{OUT}	1	$T_j = 25^\circ C$	$10.5V \leq V_{IN} \leq 23V,$ $1.0mA \leq I_{OUT} \leq 40mA$	7.6	—	8.4	V
				$1.0mA \leq I_{OUT} \leq 70mA$	7.6	—	8.4	
Quiescent Current	I_B	1	$T_j = 25^\circ C$	—	3.1	6.5	mA	
			$T_j = 125^\circ C$	—	—	6.0		
Quiescent Current Change	ΔI_B	1	$11V \leq V_{IN} \leq 23V$	—	—	1.5	mA	
			$1.0mA \leq I_{OUT} \leq 40mA$	—	—	0.1		
Output Noise Voltage	V_{NO}	2	$T_a = 25^\circ C, 10Hz \leq f \leq 100kHz$	—	60	—	μV_{rms}	
Long Term Stability	$\Delta V_{OUT} / \Delta t$	1	—	—	20	—	mV / 1.0kh	
Ripple Rejection	R.R.	3	$f = 120Hz,$ $12V \leq V_{IN} \leq 23V, T_j = 25^\circ C$	37	45	—	dB	
Dropout Voltage	$ V_{IN} - V_{OUT} $	1	$T_j = 25^\circ C, I_{OUT} = 150mA$	—	1.7	—	V	
Average Temperature Coefficient of Output Voltage	T_{CVO}	1	$I_{OUT} = 5mA$	—	-0.8	—	mV / $^\circ C$	

TA78L009AP

ELECTRICAL CHARACTERISTICS

(Unless otherwise specified, $V_{IN} = 15V$, $I_{OUT} = 40mA$, $C_{IN} = 0.33\mu F$, $C_{OUT} = 0.1\mu F$, $0^\circ C \leq T_j \leq 125^\circ C$)

CHARACTERISTIC	SYMBOL	TEST CIR-CUIT	TEST CONDITION	MIN.	TYP.	MAX.	UNIT	
Output Voltage	V_{OUT}	1	$T_j = 25^\circ C$	8.64	9.0	9.36	V	
Line Regulation	Reg.line	1	$T_j = 25^\circ C$	$11.4V \leq V_{IN} \leq 24V$	—	80	200	mV
				$12V \leq V_{IN} \leq 24V$	—	20	160	
Load Regulation	Reg.load	1	$T_j = 25^\circ C$	$1.0mA \leq I_{OUT} \leq 100mA$	—	17	90	mV
				$1.0mA \leq I_{OUT} \leq 40mA$	—	8.0	45	
Output Voltage	V_{OUT}	1	$T_j = 25^\circ C$	$11.4V \leq V_{IN} \leq 24V$	8.55	—	9.45	V
				$1.0mA \leq I_{OUT} \leq 40mA$	8.55	—	9.45	
				$1.0mA \leq I_{OUT} \leq 70mA$	8.55	—	9.45	
Quiescent Current	I_B	1	$T_j = 25^\circ C$	—	3.2	6.5	mA	
			$T_j = 125^\circ C$	—	—	6.0		
Quiescent Current Change	ΔI_B	1	$12V \leq V_{IN} \leq 24V$ $1.0mA \leq I_{OUT} \leq 40mA$	—	—	1.5	mA	
				—	—	0.1		
Output Noise Voltage	V_{NO}	2	$T_a = 25^\circ C$, $10Hz \leq f \leq 100kHz$	—	65	—	μV_{rms}	
Long Term Stability	$\Delta V_{OUT} / \Delta t$	1	—	—	21	—	mV / 1.0kh	
Ripple Rejection	R.R.	3	$f = 120Hz$, $12V \leq V_{IN} \leq 24V$, $T_j = 25^\circ C$	36	44	—	dB	
Dropout Voltage	$ V_{IN} - V_{OUT} $	1	$T_j = 25^\circ C$, $I_{OUT} = 150mA$	—	1.7	—	V	
Average Temperature Coefficient of Output Voltage	T_{CVO}	1	$I_{OUT} = 5mA$	—	-0.85	—	mV / $^\circ C$	

TA78L010AP

ELECTRICAL CHARACTERISTICS

(Unless otherwise specified, $V_{IN} = 16V$, $I_{OUT} = 40mA$, $C_{IN} = 0.33\mu F$, $C_{OUT} = 0.1\mu F$, $0^\circ C \leq T_j \leq 125^\circ C$)

CHARACTERISTIC	SYMBOL	TEST CIR-CUIT	TEST CONDITION	MIN.	TYP.	MAX.	UNIT	
Output Voltage	V_{OUT}	1	$T_j = 25^\circ C$	9.6	10	10.4	V	
Line Regulation	Reg.line	1	$T_j = 25^\circ C$	$12.5V \leq V_{IN} \leq 25V$	—	80	230	mV
				$13V \leq V_{IN} \leq 25V$	—	30	170	
Load Regulation	Reg.load	1	$T_j = 25^\circ C$	$1.0mA \leq I_{OUT} \leq 100mA$	—	18	90	mV
				$1.0mA \leq I_{OUT} \leq 40mA$	—	8.5	45	
Output Voltage	V_{OUT}	1	$T_j = 25^\circ C$	$12.5V \leq V_{IN} \leq 25V,$ $1.0mA \leq I_{OUT} \leq 40mA$	9.5	—	10.5	V
				$1.0mA \leq I_{OUT} \leq 70mA$	9.5	—	10.5	
Quiescent Current	I_B	1	$T_j = 25^\circ C$	—	3.2	6.5	mA	
			$T_j = 125^\circ C$	—	—	6.0		
Quiescent Current Change	ΔI_B	1		$13V \leq V_{IN} \leq 25V$	—	—	1.5	mA
				$1.0mA \leq I_{OUT} \leq 40mA$	—	—	0.1	
Output Noise Voltage	V_{NO}	2	$T_a = 25^\circ C, 10Hz \leq f \leq 100kHz$	—	70	—	μV_{rms}	
Long Term Stability	$\Delta V_{OUT} / \Delta t$	1	—	—	22	—	mV / 1.0kh	
Ripple Rejection	R.R.	3	$f = 120Hz,$ $13V \leq V_{IN} \leq 24V, T_j = 25^\circ C$	36	43	—	dB	
Dropout Voltage	$ V_{IN} - V_{OUT} $	1	$T_j = 25^\circ C, I_{OUT} = 150mA$	—	1.7	—	V	
Average Temperature Coefficient of Output Voltage	T_{CVO}	1	$I_{OUT} = 5mA$	—	-0.9	—	mV / $^\circ C$	

TA78L012AP

ELECTRICAL CHARACTERISTICS

(Unless otherwise specified, $V_{IN} = 19V$, $I_{OUT} = 40mA$, $C_{IN} = 0.33\mu F$, $C_{OUT} = 0.1\mu F$, $0^\circ C \leq T_j \leq 125^\circ C$)

CHARACTERISTIC	SYMBOL	TEST CIR-CUIT	TEST CONDITION	MIN.	TYP.	MAX.	UNIT	
Output Voltage	V_{OUT}	1	$T_j = 25^\circ C$	11.5	12	12.5	V	
Line Regulation	Reg.line	1	$T_j = 25^\circ C$	$14.5V \leq V_{IN} \leq 27V$	—	120	250	mV
				$16V \leq V_{IN} \leq 27V$	—	100	200	
Load Regulation	Reg.load	1	$T_j = 25^\circ C$	$1.0mA \leq I_{OUT} \leq 100mA$	—	20	100	mV
				$1.0mA \leq I_{OUT} \leq 40mA$	—	10	50	
Output Voltage	V_{OUT}	1	$T_j = 25^\circ C$	$14.5V \leq V_{IN} \leq 27V$, $1.0mA \leq I_{OUT} \leq 40mA$	11.4	—	12.6	V
				$1.0mA \leq I_{OUT} \leq 70mA$	11.4	—	12.6	
Quiescent Current	I_B	1	$T_j = 25^\circ C$	—	3.2	6.5	mA	
			$T_j = 125^\circ C$	—	—	6.0		
Quiescent Current Change	ΔI_B	1		$16V \leq V_{IN} \leq 27V$	—	—	1.5	mA
				$1.0mA \leq I_{OUT} \leq 40mA$	—	—	0.1	
Output Noise Voltage	V_{NO}	2	$T_a = 25^\circ C$, $10Hz \leq f \leq 100kHz$	—	80	—	μV_{rms}	
Long Term Stability	$\Delta V_{OUT} / \Delta t$	1	—	—	24	—	mV / 1.0kh	
Ripple Rejection	R.R.	3	$f = 120Hz$, $15V \leq V_{IN} \leq 25V$, $T_j = 25^\circ C$	36	41	—	dB	
Dropout Voltage	$ V_{IN} - V_{OUT} $	1	$T_j = 25^\circ C$, $I_{OUT} = 150mA$	—	1.7	—	V	
Average Temperature Coefficient of Output Voltage	T_{CVO}	1	$I_{OUT} = 5mA$	—	-1.0	—	mV / $^\circ C$	

TA78L132AP

ELECTRICAL CHARACTERISTICS

(Unless otherwise specified, $V_{IN} = 21V$, $I_{OUT} = 40mA$, $C_{IN} = 0.33\mu F$, $C_{OUT} = 0.1\mu F$, $0^\circ C \leq T_j \leq 125^\circ C$)

CHARACTERISTIC	SYMBOL	TEST CIR-CUIT	TEST CONDITION	MIN.	TYP.	MAX.	UNIT	
Output Voltage	V_{OUT}	1	$T_j = 25^\circ C$	12.67	13.2	13.73	V	
Line Regulation	Reg.line	1	$T_j = 25^\circ C$	$16V \leq V_{IN} \leq 28V$	—	125	270	mV
				$17V \leq V_{IN} \leq 28V$	—	105	225	
Load Regulation	Reg.load	1	$T_j = 25^\circ C$	$1.0mA \leq I_{OUT} \leq 100mA$	—	22	120	mV
				$1.0mA \leq I_{OUT} \leq 40mA$	—	11	60	
Output Voltage	V_{OUT}	1	$T_j = 25^\circ C$	$16V \leq V_{IN} \leq 28V,$ $1.0mA \leq I_{OUT} \leq 40mA$	12.54	—	13.86	V
				$1.0mA \leq I_{OUT} \leq 70mA$	12.54	—	13.86	
Quiescent Current	I_B	1	$T_j = 25^\circ C$	—	3.2	6.5	mA	
			$T_j = 125^\circ C$	—	—	6.0		
Quiescent Current Change	ΔI_B	1	$17V \leq V_{IN} \leq 28V$	—	—	1.5	mA	
			$1.0mA \leq I_{OUT} \leq 40mA$	—	—	0.1		
Output Noise Voltage	V_{NO}	2	$T_a = 25^\circ C, 10Hz \leq f \leq 100kHz$	—	90	—	μV_{rms}	
Long Term Stability	$\Delta V_{OUT} / \Delta t$	1	—	—	28	—	mV / 1.0kh	
Ripple Rejection	R.R.	3	$f = 120Hz,$ $17V \leq V_{IN} \leq 27V, T_j = 25^\circ C$	34	41	—	dB	
Dropout Voltage	$ V_{IN} - V_{OUT} $	1	$T_j = 25^\circ C, I_{OUT} = 150mA$	—	1.7	—	V	
Average Temperature Coefficient of Output Voltage	T_{CVO}	1	$I_{OUT} = 5mA$	—	-1.2	—	mV / $^\circ C$	

TA78L015AP

ELECTRICAL CHARACTERISTICS

(Unless otherwise specified, $V_{IN} = 23V$, $I_{OUT} = 40mA$, $C_{IN} = 0.33\mu F$, $C_{OUT} = 0.1\mu F$, $0^\circ C \leq T_j \leq 125^\circ C$)

CHARACTERISTIC	SYMBOL	TEST CIR-CUIT	TEST CONDITION	MIN.	TYP.	MAX.	UNIT	
Output Voltage	V_{OUT}	1	$T_j = 25^\circ C$	14.4	15	15.6	V	
Line Regulation	Reg.line	1	$T_j = 25^\circ C$	$17.5V \leq V_{IN} \leq 30V$	—	130	300	mV
				$20V \leq V_{IN} \leq 30V$	—	110	250	
Load Regulation	Reg.load	1	$T_j = 25^\circ C$	$1.0mA \leq I_{OUT} \leq 100mA$	—	25	150	mV
				$1.0mA \leq I_{OUT} \leq 40mA$	—	12	75	
Output Voltage	V_{OUT}	1	$T_j = 25^\circ C$	$17.5V \leq V_{IN} \leq 30V,$ $1.0mA \leq I_{OUT} \leq 40mA$	14.25	—	15.75	V
				$1.0mA \leq I_{OUT} \leq 70mA$	14.25	—	15.75	
Quiescent Current	I_B	1	$T_j = 25^\circ C$	—	3.3	6.5	mA	
			$T_j = 125^\circ C$	—	—	6.0		
Quiescent Current Change	ΔI_B	1		$20V \leq V_{IN} \leq 30V$	—	—	1.5	mA
				$1.0mA \leq I_{OUT} \leq 40mA$	—	—	0.1	
Output Noise Voltage	V_{NO}	2	$T_a = 25^\circ C, 10Hz \leq f \leq 100kHz$	—	90	—	μV_{rms}	
Long Term Stability	$\Delta V_{OUT} / \Delta t$	1	—	—	30	—	mV / 1.0kh	
Ripple Rejection	R.R.	3	$f = 120Hz,$ $18.5V \leq V_{IN} \leq 28.5V, T_j = 25^\circ C$	34	40	—	dB	
Dropout Voltage	$ V_{IN} - V_{OUT} $	1	$T_j = 25^\circ C, I_{OUT} = 150mA$	—	1.7	—	V	
Average Temperature Coefficient of Output Voltage	T_{CVO}	1	$I_{OUT} = 5mA$	—	-1.3	—	mV / $^\circ C$	

TA78L018AP

ELECTRICAL CHARACTERISTICS

(Unless otherwise specified, $V_{IN} = 27V$, $I_{OUT} = 40mA$, $C_{IN} = 0.33\mu F$, $C_{OUT} = 0.1\mu F$, $0^\circ C \leq T_j \leq 125^\circ C$)

CHARACTERISTIC	SYMBOL	TEST CIR-CUIT	TEST CONDITION	MIN.	TYP.	MAX.	UNIT	
Output Voltage	V_{OUT}	1	$T_j = 25^\circ C$	17.3	18	18.7	V	
Line Regulation	Reg.line	1	$T_j = 25^\circ C$	$21.4V \leq V_{IN} \leq 33V$	—	32	325	mV
				$22V \leq V_{IN} \leq 33V$	—	27	275	
Load Regulation	Reg.load	1	$T_j = 25^\circ C$	$1.0mA \leq I_{OUT} \leq 100mA$	—	30	170	mV
				$1.0mA \leq I_{OUT} \leq 40mA$	—	15	75	
Output Voltage	V_{OUT}	1	$T_j = 25^\circ C$	$21.4V \leq V_{IN} \leq 33V$,	17.1	—	18.9	V
				$1.0mA \leq I_{OUT} \leq 40mA$				
				$1.0mA \leq I_{OUT} \leq 70mA$	17.1	—	18.9	
Quiescent Current	I_B	1	$T_j = 25^\circ C$	—	3.3	6.5	mA	
			$T_j = 125^\circ C$	—	—	6.0		
Quiescent Current Change	ΔI_B	1		$22V \leq V_{IN} \leq 33V$	—	—	1.5	mA
				$1.0mA \leq I_{OUT} \leq 40mA$	—	—	0.1	
Output Noise Voltage	V_{NO}	2	$T_a = 25^\circ C$, $10Hz \leq f \leq 100kHz$	—	150	—	μV_{rms}	
Long Term Stability	$\Delta V_{OUT} / \Delta t$	1	—	—	45	—	mV / 1.0kh	
Ripple Rejection	R.R.	3	$f = 120Hz$, $23V \leq V_{IN} \leq 33V$, $T_j = 25^\circ C$	32	38	—	dB	
Dropout Voltage	$ V_{IN} - V_{OUT} $	1	$T_j = 25^\circ C$, $I_{OUT} = 150mA$	—	1.7	—	V	
Average Temperature Coefficient of Output Voltage	T_{CVO}	1	$I_{OUT} = 5mA$	—	-1.5	—	mV / $^\circ C$	

TA78L020AP

ELECTRICAL CHARACTERISTICS

(Unless otherwise specified, $V_{IN} = 29V$, $I_{OUT} = 40mA$, $C_{IN} = 0.33\mu F$, $C_{OUT} = 0.1\mu F$, $0^\circ C \leq T_j \leq 125^\circ C$)

CHARACTERISTIC	SYMBOL	TEST CIR-CUIT	TEST CONDITION	MIN.	TYP.	MAX.	UNIT	
Output Voltage	V_{OUT}	1	$T_j = 25^\circ C$	19.2	20	20.8	V	
Line Regulation	Reg.line	1	$T_j = 25^\circ C$	$23.5V \leq V_{IN} \leq 35V$	—	33	330	mV
				$24V \leq V_{IN} \leq 35V$	—	28	285	
Load Regulation	Reg.load	1	$T_j = 25^\circ C$	$1.0mA \leq I_{OUT} \leq 100mA$	—	33	180	mV
				$1.0mA \leq I_{OUT} \leq 40mA$	—	17	90	
Output Voltage	V_{OUT}	1	$T_j = 25^\circ C$	$23.5V \leq V_{IN} \leq 35V,$	19.0	—	21.0	V
				$1.0mA \leq I_{OUT} \leq 40mA$	19.0	—	21.0	
				$1.0mA \leq I_{OUT} \leq 70mA$	19.0	—	21.0	
Quiescent Current	I_B	1	$T_j = 25^\circ C$	—	3.3	6.5	mA	
			$T_j = 125^\circ C$	—	—	6.0		
Quiescent Current Change	ΔI_B	1		$24V \leq V_{IN} \leq 35V$	—	—	1.5	mA
				$1.0mA \leq I_{OUT} \leq 40mA$	—	—	0.1	
Output Noise Voltage	V_{NO}	2	$T_a = 25^\circ C, 10Hz \leq f \leq 100kHz$	—	170	—	μV_{rms}	
Long Term Stability	$\Delta V_{OUT} / \Delta t$	1	—	—	49	—	mV / 1.0kh	
Ripple Rejection	R.R.	3	$f = 120Hz,$ $25V \leq V_{IN} \leq 35V, T_j = 25^\circ C$	31	37	—	dB	
Dropout Voltage	$ V_{IN} - V_{OUT} $	1	$T_j = 25^\circ C, I_{OUT} = 150mA$	—	1.7	—	V	
Average Temperature Coefficient of Output Voltage	T_{CVO}	1	$I_{OUT} = 5mA$	—	-1.7	—	mV / $^\circ C$	

TA78L024AP

ELECTRICAL CHARACTERISTICS

(Unless otherwise specified, $V_{IN} = 33V$, $I_{OUT} = 40mA$, $C_{IN} = 0.33\mu F$, $C_{OUT} = 0.1\mu F$, $0^\circ C \leq T_j \leq 125^\circ C$)

CHARACTERISTIC	SYMBOL	TEST CIR-CUIT	TEST CONDITION	MIN.	TYP.	MAX.	UNIT
Output Voltage	V_{OUT}	1	$T_j = 25^\circ C$	23	24	25	V
Line Regulation	Reg.line	1	$T_j = 25^\circ C$	—	35	350	mV
				—	30	300	
Load Regulation	Reg.load	1	$T_j = 25^\circ C$	—	40	200	mV
				—	20	100	
Output Voltage	V_{OUT}	1	$T_j = 25^\circ C$	22.8	—	25.2	V
				22.8	—	25.2	
				—	—	—	
Quiescent Current	I_B	1	$T_j = 25^\circ C$	—	3.5	6.5	mA
			$T_j = 125^\circ C$	—	—	6.0	
Quiescent Current Change	ΔI_B	1	$28V \leq V_{IN} \leq 38V$	—	—	1.5	mA
			$1.0mA \leq I_{OUT} \leq 40mA$	—	—	0.1	
Output Noise Voltage	V_{NO}	2	$T_a = 25^\circ C$, $10Hz \leq f \leq 100kHz$	—	200	—	μV_{rms}
Long Term Stability	$\Delta V_{OUT} / \Delta t$	1	—	—	56	—	mV / 1.0kh
Ripple Rejection	R.R.	3	$f = 120Hz$, $29V \leq V_{IN} \leq 39V$, $T_j = 25^\circ C$	31	35	—	dB
Dropout Voltage	$ V_{IN} - V_{OUT} $	1	$T_j = 25^\circ C$, $I_{OUT} = 150mA$	—	1.7	—	V
Average Temperature Coefficient of Output Voltage	T_{CVO}	1	$I_{OUT} = 5mA$	—	-2.0	—	mV / $^\circ C$

TEST CIRCUIT 1 / STANDARD APPLICATION

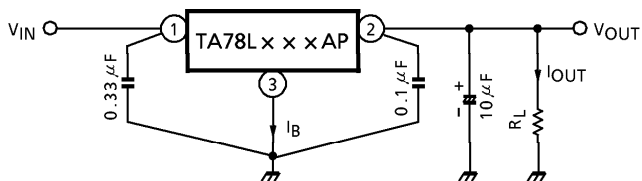

TEST CIRCUIT 2 V_{NO}

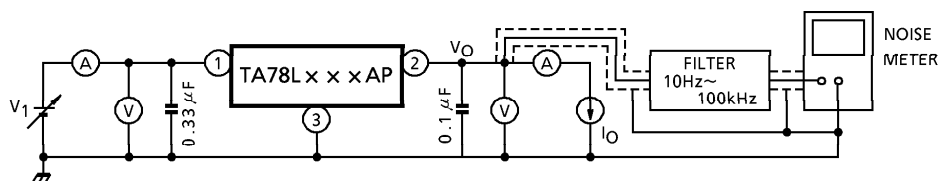

TEST CIRCUIT 3 R.R.

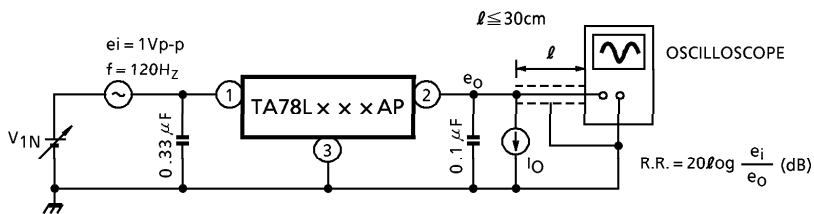

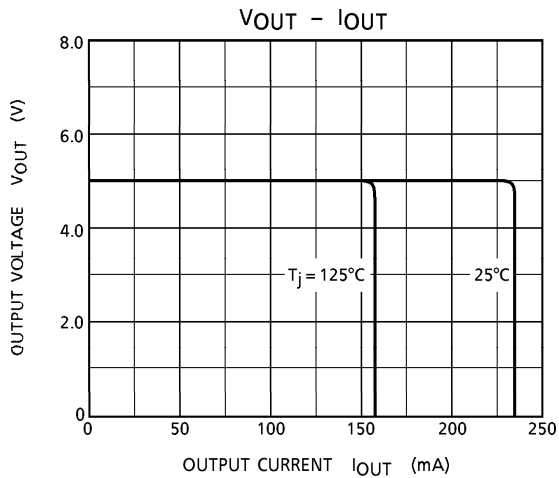
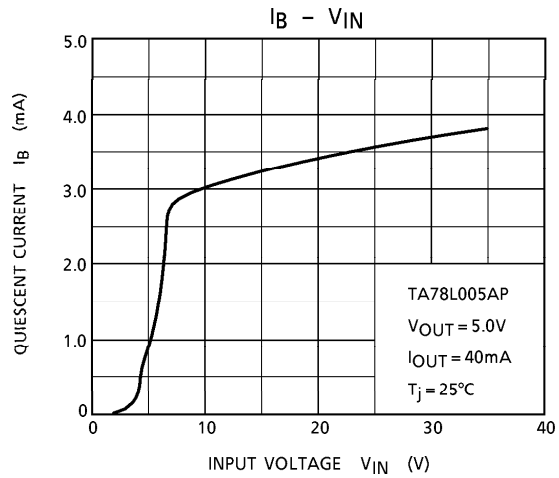
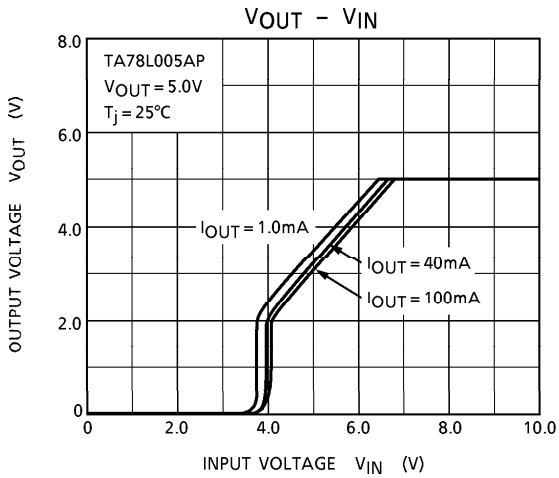
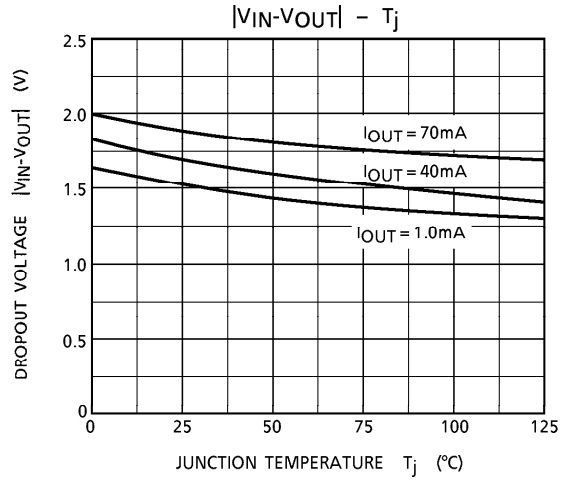
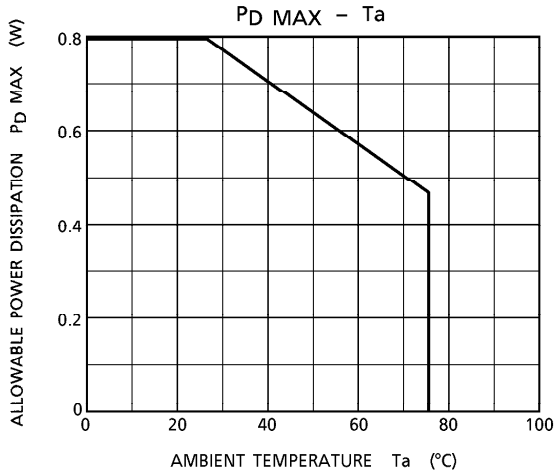

Precautions for Use

If high voltage in excess of output voltage (TYP. value) of IC is applied to its output terminal, IC may be destroyed. In this case, connect a Zener diode between the output terminal and GND to prevent application of excessive voltage. In particular, in such a current boosting circuit as shown in Application Circuit Example (2), if input voltage is suddenly applied by stages and furthermore, load is light, excessive voltage may be applied transiently to the output terminal of IC. In such a case as this, it may become necessary to increase capacity of output capacitor as appropriate, use a smaller R₁ (a resistor for bypassing IC bias current) or gradually rise input voltage in addition to use of a Zener diode as mentioned above.

APPLICATION CIRCUIT

(1) STANDARD APPLICATION

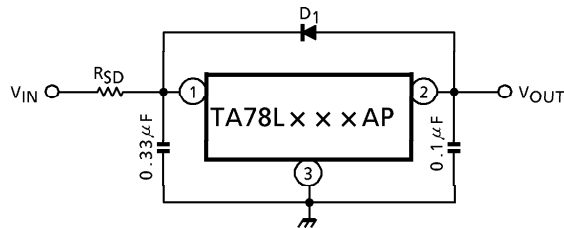

D₁ : IC protective diode
 When surge voltage is applied to IC output terminal or V_{IN} < V_{OUT} at the time of power ON/OFF, always connect the high speed swithing diode D₁.
 R_{SD} : Power limiting resistor
 If V_{IN} is too high, always connect R_{SD} in order to reduce power consumption of IC.

(2) A. CURRENT BOOST VOLTAGE REGULATOR

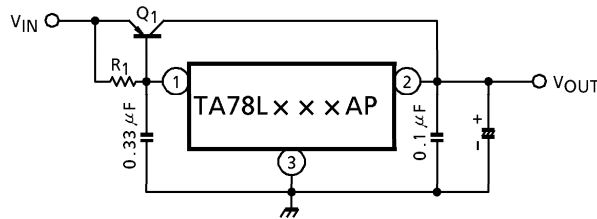

Use a required rediation plate for Q₁.

$$R_1 \leq \frac{V_{BE1}}{I_B \text{ MAX}}$$

where, V_{BE1} : V_{BE} of external transistor Q₁.
 I_B MAX : Max. bias current of IC.

B. SHORT-CIRCUIT PROTECTION

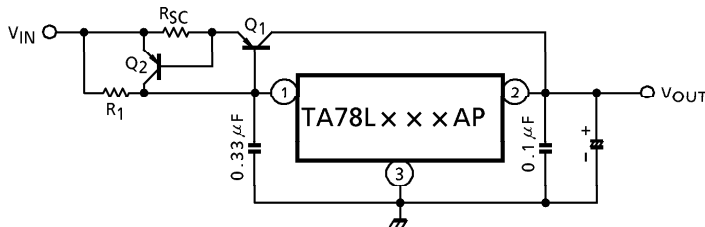

$$R_{SC} = \frac{V_{BE2}}{I_{SC}}$$

where, I_{SC} : Short-Circuit current

(3) CURRENT REGULATOR

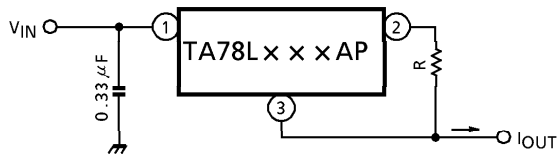

$$I_{OUT} = \frac{V_{OUT}}{R} + I_B$$

(4) VOLTAGE BOOST REGULATOR

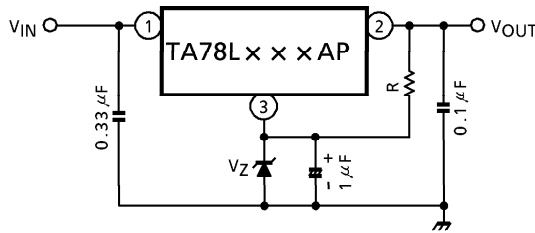

$V_{OUT} = V_Z + V_{OUT} \text{ (of IC)}$
A little of current in resistor R is needed.

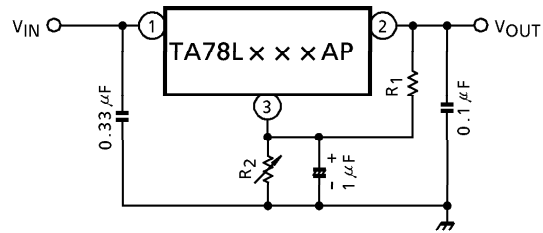

$$V_{OUT} = R_2 \left(I_B \cdot \frac{V_{OUT} \text{ (of IC)}}{R_1} \right) + V_{OUT} \text{ (of IC)}$$

(5) NEGATIVE REGULATOR

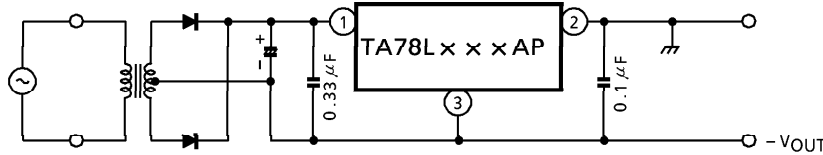

(6) POSITIVE AND NEGATIVE REGULATOR

