

Overview

The STK390-120 is a high-accuracy convergence correction circuit hybrid IC designed to complement the advances in modern high-resolution video projectors and CRT displays. It incorporates a convergence circuit that operates at high frequency with a corresponding high slew rate, without the increase in power dissipation and mounting space that discrete devices would entail. It also features a built-in supply switching circuit for high efficiency.

Applications

- Video projectors
- Ultrahigh definition CRT displays

Features

- High absolute maximum supply voltage (V_{CC} max = $\pm 44V$)
- Low thermal resistance ($\theta_{j-c} = 2.7^{\circ}C/W$)
- High temperature stability (strengthened idling current temperature compensation)
- Reduced correction coil inductance to improve stability (over the range $f_H \leq 85kHz$)
- Supply switching circuit built-in to enable large-scale decreases in power dissipation
- Improved convergence characteristics for CRT displays

Package Dimensions

unit: mm

4151

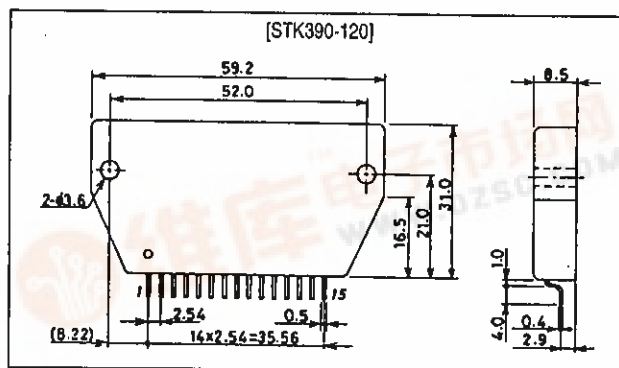

STK390-120

Specifications

Maximum Ratings at $T_a = 25^\circ\text{C}$

Parameter	Symbol	Conditions	Ratings	Unit
Maximum supply voltage	$V_{CC\ max}$	V_{CCH}, V_{CCL}	± 44	V
Maximum collector current	I_c	Tr9, 10, 13, 14	4.0	A
Thermal resistance (1)	θ_{j-c1}	Tr9, 10 (per transistor)	2.7	$^\circ\text{C/W}$
Thermal resistance (2)	θ_{j-c2}	Tr13, 14 (per transistor)	15.0	$^\circ\text{C/W}$
Junction temperature	T_j		150	$^\circ\text{C}$
Operating substrate temperature	T_c		115	$^\circ\text{C}$
Storage temperature	T_{stg}		-30 to +115	$^\circ\text{C}$

Operating Characteristics at $T_c = 25^\circ\text{C}$, $V_{CCH} = \pm 35\text{V}$, $V_{CCL} = \pm 15\text{V}$

Parameter	Symbol	Conditions	min	typ	max	Unit
Output amplifier block						
Output noise voltage	V_{NO}	$R_g = 10\text{k}\Omega$	-	-	0.2	mVrms
Quiescent current	I_{CCO}	$R_g = 10\text{k}\Omega$	-	10	20	mA
Neutral voltage	V_N	$R_g = 10\text{k}\Omega$	-50	0	+50	mV
Output delay time	t_D	$R_g = 50\Omega$, $f = 100\text{kHz}$, triangular wave input, $V_{OUT} = 1.5\text{Vp-p}$	-	-	0.1	μs
Output saturation voltage (upper)	$V_{sat\ 10-7}$	Between pins 10 and 7, $I = 1.0\text{A}$	-	1.0	1.5	V
Output saturation voltage (lower)	$V_{sat\ 7-12}$	Between pins 7 and 12, $I = 1.0\text{A}$	-	1.7	2.2	V
Supply switching block						
Supply switching circuit saturation voltage (upper)	$V_{sat\ 9-10}$	Between pins 9 and 10, $I = 1.0\text{A}$	-	1.0	1.5	V
Supply switching circuit saturation voltage (lower)	$V_{sat\ 12-8}$	Between pins 12 and 8, $I = 1.0\text{A}$	-	1.0	1.5	V
Supply switching pulse width (upper)	t_{PW10}	Pin 10 $I = 1.0\text{A}$, $f = 100\text{kHz}$, BLK input pulse width = $1.0\mu\text{s}$	-	-	3.0	μs
Supply switching pulse width (lower)	t_{PW12}	Pin 12 $I = 1.0\text{A}$, $f = 100\text{kHz}$, BLK input pulse width = $1.0\mu\text{s}$	-	-	3.0	μs

Note. All measurements are made using a constant-voltage supply.

Equivalent Circuit

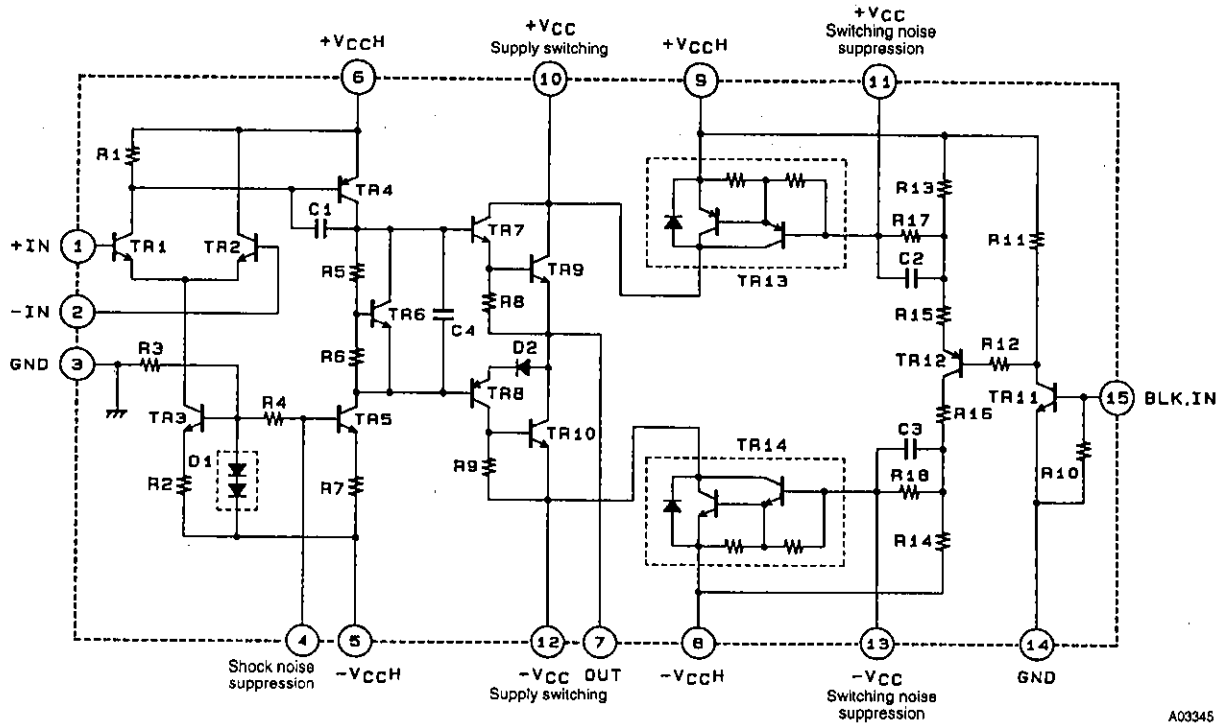

STK390-120

Sample Application Circuit

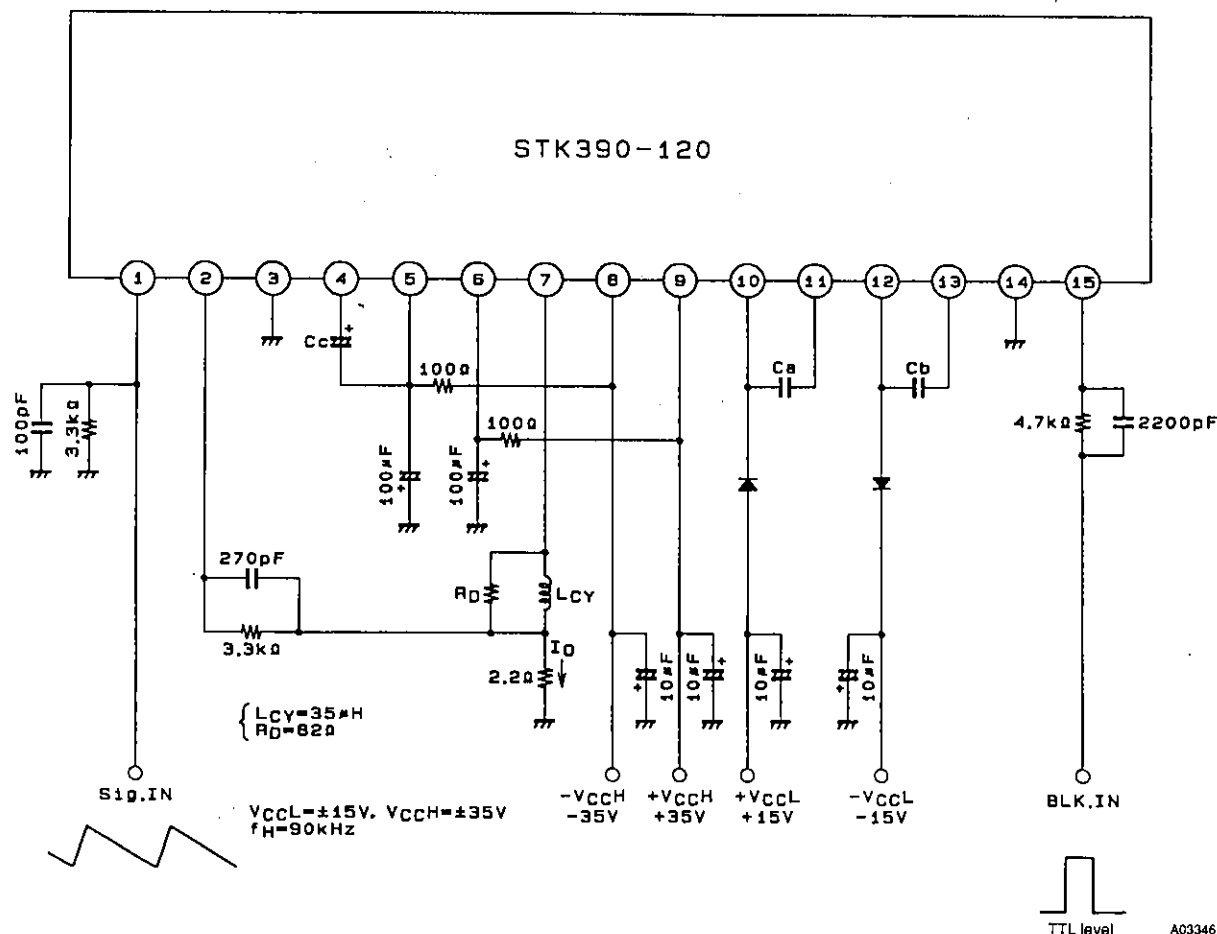

- Notes. Ca, Cb (0 to 120pF) are for V_{CC} switch noise suppression.
Cc (47 to 220μF) is for supply switch ON shock noise suppression.

- No products described or contained herein are intended for use in surgical implants, life-support systems, aerospace equipment, nuclear power control systems, vehicles, disaster/crime-prevention equipment and the like, the failure of which may directly or indirectly cause injury, death or property loss.
- Anyone purchasing any products described or contained herein for an above-mentioned use shall:
 - ① Accept full responsibility and indemnify and defend SANYO ELECTRIC CO., LTD., its affiliates, subsidiaries and distributors and all their officers and employees, jointly and severally, against any and all claims and litigation and all damages, cost and expenses associated with such use:
 - ② Not impose any responsibility for any fault or negligence which may be cited in any such claim or litigation on SANYO ELECTRIC CO., LTD., its affiliates, subsidiaries and distributors or any of their officers and employees, jointly or severally.
- Information (including circuit diagrams and circuit parameters) herein is for example only; it is not guaranteed for volume production. SANYO believes information herein is accurate and reliable, but no guarantees are made or implied regarding its use or any infringements of intellectual property rights or other rights of third parties.