

2SK2902-01MR

查询2SK2902-01MR供应商

捷多邦, 专业PCB打样工厂, 24小时加急出货

FUJI POWER MOS-FET

N-CHANNEL SILICON POWER MOS-FET

Features

- High speed switching
- Low on-resistance
- No secondary breakdown
- Low driving power
- Avalanche-proof

Applications

- Switching regulators
- UPS (Uninterruptible Power Supply)
- DC-DC converters

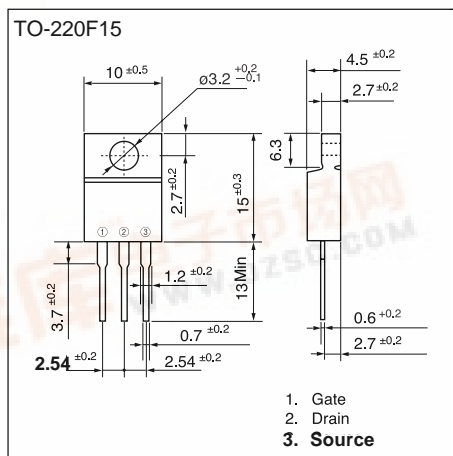

Maximum ratings and characteristic Absolute maximum ratings

(T_c=25°C unless otherwise specified)

Item	Symbol	Rating	Unit
Drain-source voltage	V _{DS}	60	V
Continuous drain current	I _D	±45	A
Pulsed drain current	I _{D(puls)}	±180	A
Gate-source voltage	V _{GS}	±30	V
Maximum Avalanche Energy	E _{AV*1}	461.9	mJ
Max. power dissipation	P _D	40	W
Operating and storage temperature range	T _{ch} T _{stg}	+150 -55 to +150	°C

*1 L=0.304mH, V_{cc}=24V

Equivalent circuit schematic

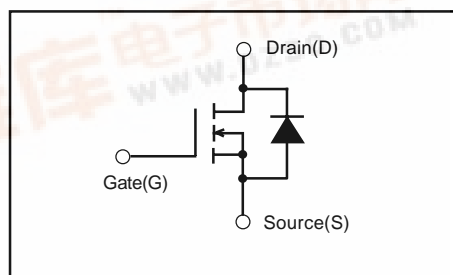

Electrical characteristics (T_c =25°C unless otherwise specified)

Item	Symbol	Test Conditions	Min.	Typ.	Max.	Units
Drain-source breakdown voltage	BV _{DSS}	I _D =1mA V _{GS} =0V	60			V
Gate threshold voltage	V _{GS(th)}	I _D =10mA V _{DS} =V _{GS}	2.5	3.0	3.5	V
Zero gate voltage drain current	I _{DSS}	V _{DS} =60V V _{GS} =0V	T _{ch} =25°C	10	500	μA
			T _{ch} =125°C	0.2	1.0	mA
Gate-source leakage current	I _{GSS}	V _{GS} =±30V V _{DS} =0V		10	100	nA
Drain-source on-state resistance	R _{DSON}	I _D =22.5A V _{GS} =10V		12.0	14.5	mΩ
Forward transconductance	g _{fs}	I _D =22.5A V _{DS} =25V	10.0	25.0		S
Input capacitance	C _{iss}	V _{DS} =25V		2300	3450	pF
Output capacitance	C _{oss}	V _{GS} =0V		910	1370	pF
Reverse transfer capacitance	C _{rss}	f=1MHz		260	390	pF
Turn-on time t _{on}	td(on)	V _{CC} =30V I _D =45A		18	30	ns
	t _r	V _{GS} =10V		55	80	ns
Turn-off time t _{off}	td(off)	R _{GS} =10Ω		70	120	ns
	t _f			48	80	ns
Avalanche capability	I _{AV}	L=100μH T _{ch} =25°C	45			A
Diode forward on-voltage	V _{SD}	I _F =45A V _{GS} =0V T _{ch} =25°C		1.0	1.5	V
Reverse recovery time	t _{rr}	I _F =45A V _{GS} =0V		60		ns
Reverse recovery charge	Q _{rr}	-di/dt=100A/μs T _{ch} =25°C		0.11		μC

Thermal characteristics

Item	Symbol	Test Conditions	Min.	Typ.	Max.	Units
Thermal resistance	R _{th(ch-c)}	channel to case			3.125	°C/W
	R _{th(ch-a)}	channel to ambient			62.5	°C/W



Characteristics

