



**Integrated
Circuit
Systems, Inc.**

ICS9250-23

Frequency Generator & Integrated Buffers for Celeron & PII/III™

Recommended Application:

810/810E type chipset

Output Features:

- 2 - CPUs @ 2.5V, up to 166MHz.
- 13 - SDRAM @ 3.3V, up to 166MHz.
- 2 - 3V66 @ 3.3V, 2x PCI MHz.
- 8 - PCI @3.3V.
- 1 - 48MHz, @3.3V fixed.
- 1 - 24MHz @ 3.3V
- 2 - REF @3.3V, 14.318MHz.

Features:

- Up to 166MHz frequency support
- Support power management through PD#.
- Spread spectrum for EMI control ($\pm 0.25\%$) center spread.
- Uses external 14.318MHz crystal
- FS pins for frequency select

Key Specifications:

- CPU Output Jitter: <250ps
- IOAPIC Output Jitter: <500ps
- 48MHz, 3V66, PCI Output Jitter: <500ps
- Ref Output Jitter. <1000ps
- CPU Output Skew: <175ps
- PCI Output Skew: <500ps
- 3V66 Output Skew <175ps
- For group skew timing, please refer to the Group Timing Relationship Table.

Power Groups

GNDREF, VDDREF = REF, Crystal
 GND3V66, VDD3V66 = 3V66
 GNDPCI, VDDPCI = PCICLKs
 GNDCOR, VDDCOR = PLLCORE
 GND48, VDD48 = 48
 GNDSDR, VDDSDR = SDRAM
 GNDLCPU, VDDLCPUCPU = CPUCLK
 GNDLPCI, VDDLAPIC = IOAPIC

Pin Configuration

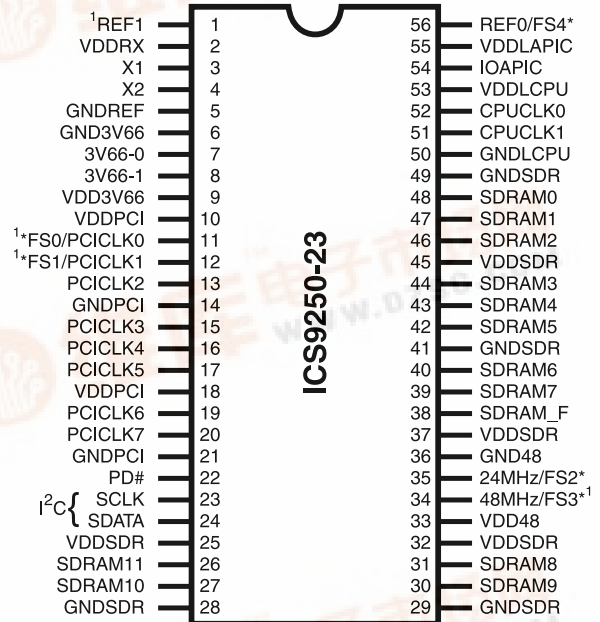

56-Pin 300 mil SSOP

1. These pins will have 2X drive strength.
- * 120K ohm pull-up to VDD on indicated inputs.

Block Diagram

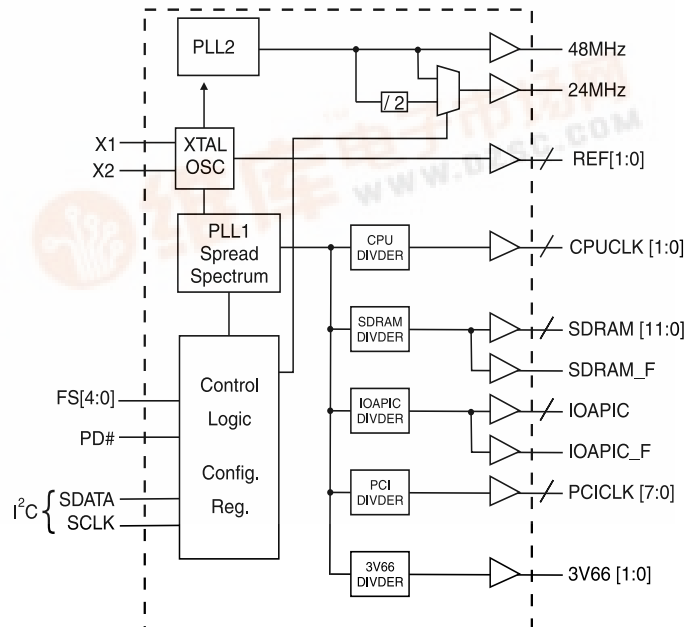



General Description

The **ICS9250-23** is a single chip clock solution for desktop designs using the 810/810E style chipset. It provides all necessary clock signals for such a system.

Spread spectrum may be enabled through I²C programming. Spread spectrum typically reduces system EMI by 8dB to 10dB. This simplifies EMI qualification without resorting to board design iterations or costly shielding. The ICS9250-23 employs a proprietary closed loop design, which tightly controls the percentage of spreading over process and temperature variations.

Serial programming I²C interface allows changing functions, stop clock programming and frequency selection.

Pin Configuration

PIN NUMBER	PIN NAME	TYPE	DESCRIPTION
1	REF1	OUT	3.3V, 14.318MHz reference clock output.
2, 9, 10, 18, 25, 32, 33, 37, 45	VDD	PWR	3.3V power supply.
3	X1	IN	Crystal input, has internal load cap (33pF) and feedback resistor from X2.
4	X2	OUT	Crystal output, nominally 14.318MHz. Has internal load cap (33pF)
5, 6, 14, 21, 28, 29, 36, 41, 49	GND	PWR	Ground pins for 3.3V supply.
8, 7	3V66 [1:0]	OUT	3.3V Fixed 66MHz clock outputs for HUB.
11	PCICLK0 ¹	OUT	3.3V PCI clock outputs, with Synchronous CPUCLKS.
	FS0	IN	Logic input frequency select bit. Input latched at power on.
12	PCICLK1 ¹	OUT	3.3V PCI clock outputs, with Synchronous CPUCLKS.
	FS1	IN	Logic input frequency select bit. Input latched at power on.
20, 19, 17, 16, 15, 13	PCICLK [7:2]	OUT	3.3V PCI clock outputs, with Synchronous CPUCLKS.
22	PD#	IN	Asynchronous active low input pin used to power down the device into a low power state. The internal clocks are disabled and the VCO and the crystal are stopped. The latency of the power down will not be greater than 3ms.
23	SCLK	IN	Clock input of I ² C input.
24	SDATA	I/O	Data pin for I ² C circuitry 5V tolerant.
34	48MHz	OUT	3.3V Fixed 48MHz clock output for USB.
	FS3	IN	Logic input frequency select bit. Input latched at power on.
35	FS2	IN	Logic input frequency select bit. Input latched at power on.
	24MHz	OUT	3.3V fixed 24MHz output.
38	SDRAM_F	OUT	3.3V free running 100MHz SDRAM not affected by I ² C.
26, 27, 30, 31, 39, 40, 42, 43, 44, 46, 47, 48	SDRAM [11:0]	OUT	3.3V output running 100MHz. All SDRAM outputs can be turned off through I ² C.
50	GNDL	PWR	Ground for 2.5V power supply for CPU & APIC.
51, 52	CPUCLK [1:0]	OUT	2.5V Host bus clock output. Output frequency derived from FS pins.
53, 55	VDDL	PWR	2.5V power supply for CPU, IOAPIC.
54	IOAPIC	OUT	2.5V clock outputs running at 16.67MHz.
56	FS4	IN	Logic input frequency select bit. Input latched at power on.
	REF0 ¹	OUT	3.3V, 14.318MHz reference clock output.



Frequency Selection

FS4	FS3	FS2	FS1	FS0	CPU MHz	SDRAM MHz	3V66 MHz	PCI MHz	IOAPIC MHz
0	0	0	0	0	69.00	103.50	69.00	34.50	17.25
0	0	0	0	1	70.00	105.00	70.00	35.00	17.50
0	0	0	1	0	71.00	106.50	71.00	35.50	17.75
0	0	0	1	1	66.90	100.35	66.90	33.45	16.73
0	0	1	0	0	72.00	108.00	72.00	36.00	18.00
0	0	1	0	1	75.00	112.50	75.00	37.50	18.75
0	0	1	1	0	76.60	114.90	76.60	38.40	19.20
0	0	1	1	1	85.00	127.50	85.00	42.50	21.25
0	1	0	0	0	68.00	102.00	68.00	34.00	17.00
0	1	0	0	1	74.00	111.00	74.00	37.00	18.50
0	1	0	1	0	140.00	140.00	70.00	35.00	17.50
0	1	0	1	1	133.33	133.33	66.67	33.33	16.67
0	1	1	0	0	150.00	150.00	75.00	37.50	18.75
0	1	1	0	1	155.00	155.00	77.50	38.75	19.38
0	1	1	1	0	166.00	166.00	83.00	41.50	22.75
0	1	1	1	1	166.00	166.00	111.00	55.80	27.90
1	0	0	0	0	111.77	111.77	74.52	37.26	18.63
1	0	0	0	1	104.78	104.78	69.86	34.93	17.46
1	0	0	1	0	109.51	109.51	73.01	36.50	18.25
1	0	0	1	1	100.90	100.90	67.27	33.63	16.82
1	0	1	0	0	117.00	117.00	78.50	39.25	19.63
1	0	1	0	1	123.75	123.75	82.50	41.25	20.62
1	0	1	1	0	133.33	133.33	88.89	44.44	22.22
1	0	1	1	1	142.50	142.50	95.00	47.50	23.75
1	1	0	0	0	136.00	102.25	68.50	34.25	17.13
1	1	0	0	1	140.00	105.00	70.00	35.00	17.50
1	1	0	1	0	143.00	107.50	72.00	36.00	18.00
1	1	0	1	1	133.90	100.68	67.45	33.73	16.86
1	1	1	0	0	146.67	110.00	73.33	36.67	18.33
1	1	1	0	1	149.33	112.00	74.67	37.33	18.67
1	1	1	1	0	153.30	115.29	77.24	38.62	19.30
1	1	1	1	1	166.67	125.32	83.34	41.67	20.83

Clock Enable Configuration

PD#	CPUCLK	SDRAM	IOAPIC	66MHz	PCICLK	REF, 48MHz	Osc	VCOs
0	LOW	LOW	LOW	LOW	LOW	LOW	OFF	OFF
1	ON	ON	ON	ON	ON	ON	ON	ON



Power Down Waveform

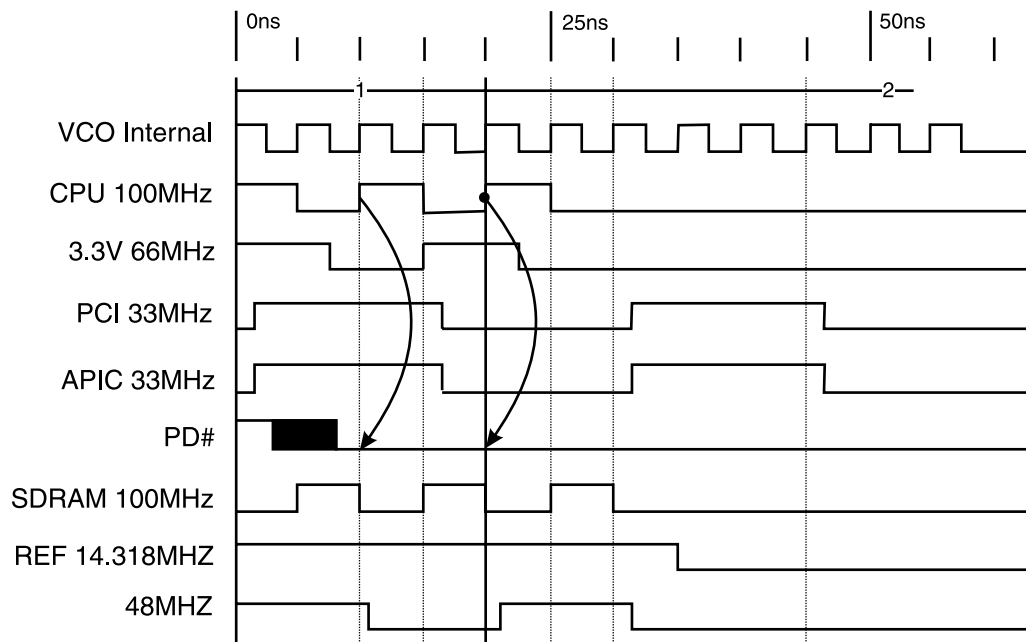

Note

- 1. After PD# is sampled active (Low) for 2 consecutive rising edges of CPUCLKs, all the output clocks are driven Low on their next High to Low transition.
- 2. Power-up latency <3ms.
- 3. Waveform shown for 100MHz



Shared Pin Operation - Input/Output Pins

The I/O pins designated by (input/output) serve as dual signal functions to the device. During initial power-up, they act as input pins. The logic level (voltage) that is present on these pins at this time is read and stored into a 5-bit internal data latch. At the end of Power-On reset, (see AC characteristics for timing values), the device changes the mode of operations for these pins to an output function. In this mode the pins produce the specified buffered clocks to external loads.

To program (load) the internal configuration register for these pins, a resistor is connected to either the VDD (logic 1) power supply or the GND (logic 0) voltage potential. A 10 Kilohm (10K) resistor is used both to provide the solid CMOS programming voltage needed during the power-up programming period and to provide an insignificant load on the output clock during the subsequent operating period.

Figure 1 shows a means of implementing this function when a switch or 2 pin header is used. When no jumper is installed the pin will be pulled high. With the jumper in place the pin will be pulled low. If programmability is not necessary, then only a single resistor is necessary. The programming resistors should be located close to the series termination resistor to minimize the current loop area. It is more important to locate the series termination resistor close to the driver than the programming resistor.

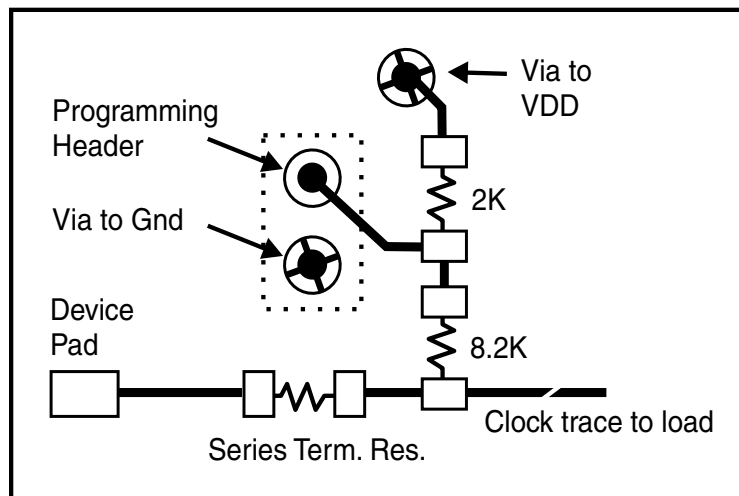

Fig. 1



General I²C serial interface information

The information in this section assumes familiarity with I²C programming. For more information, contact ICS for an I²C programming application note.

How to Write:

- Controller (host) sends a start bit.
- Controller (host) sends the write address D2_(H)
- ICS clock will *acknowledge*
- Controller (host) sends a dummy command code
- ICS clock will *acknowledge*
- Controller (host) sends a dummy byte count
- ICS clock will *acknowledge*
- Controller (host) starts sending first byte (Byte 0) through byte 5
- ICS clock will *acknowledge* each byte *one at a time*.
- Controller (host) sends a Stop bit

How to Write:	
Controller (Host)	ICS (Slave/Receiver)
Start Bit	
Address D2 _(H)	
	ACK
Dummy Command Code	
	ACK
Dummy Byte Count	
	ACK
Byte 0	
	ACK
Byte 1	
	ACK
Byte 2	
	ACK
Byte 3	
	ACK
Byte 4	
	ACK
Byte 5	
	ACK
Stop Bit	

How to Read:

- Controller (host) will send start bit.
- Controller (host) sends the read address D3_(H)
- ICS clock will *acknowledge*
- ICS clock will send the *byte count*
- Controller (host) acknowledges
- ICS clock sends first byte (*Byte 0*) through *byte 5*
- Controller (host) will need to acknowledge each byte
- Controller (host) will send a stop bit

How to Read:	
Controller (Host)	ICS (Slave/Receiver)
Start Bit	
Address D3 _(H)	
	ACK
	Byte Count
ACK	
	Byte 0
ACK	
	Byte 1
ACK	
	Byte 2
ACK	
	Byte 3
ACK	
	Byte 4
ACK	
	Byte 5
ACK	
Stop Bit	

Notes:

1. The ICS clock generator is a slave/receiver, I²C component. It can read back the data stored in the latches for verification. **Read-Back will support Intel PIIX4 "Block-Read" protocol.**
2. The data transfer rate supported by this clock generator is 100K bits/sec or less (standard mode)
3. The input is operating at 3.3V logic levels.
4. The data byte format is 8 bit bytes.
5. To simplify the clock generator I²C interface, the protocol is set to use only "**Block-Writes**" from the controller. The bytes must be accessed in sequential order from lowest to highest byte with the ability to stop after any complete byte has been transferred. The Command code and Byte count shown above must be sent, but the data is ignored for those two bytes. The data is loaded until a Stop sequence is issued.
6. At power-on, all registers are set to a default condition, as shown.



Byte 0: Functionality and frequency select register (Default=0)
(1 = enable, 0 = disable)

Bit	Description										PWD
Bit (2, 7:4)	Bit (2,7:4)					CPUCLK MHz	SDRAM MHz	3V66 MHz	PCICLK	IOAPIC MHz	00100 Note 1
	0	0	0	0	0	69.00	103.50	69.00	34.50	17.25	
	0	0	0	0	1	70.00	105.00	70.00	35.00	17.50	
	0	0	0	1	0	71.00	106.50	71.00	35.50	17.75	
	0	0	0	1	1	66.90	100.35	66.90	33.45	16.73	
	0	0	1	0	0	72.00	108.00	72.00	36.00	18.00	
	0	0	1	0	1	75.00	112.50	75.00	37.50	18.75	
	0	0	1	1	0	76.60	114.90	76.60	38.40	19.20	
	0	0	1	1	1	85.00	127.50	85.00	42.50	21.25	
	0	1	0	0	0	68.00	102.00	68.00	34.00	17.00	
	0	1	0	0	1	74.00	111.00	74.00	37.00	18.50	
	0	1	0	1	0	140.00	140.00	70.00	35.00	17.50	
	0	1	0	1	1	133.33	133.33	66.67	33.33	16.67	
	0	1	1	0	0	150.00	150.00	75.00	37.50	18.75	
	0	1	1	0	1	155.00	155.00	77.50	38.75	19.38	
	0	1	1	1	0	166.00	166.00	83.00	41.50	22.75	
	0	1	1	1	1	166.00	166.00	111.00	55.80	27.90	
	1	0	0	0	0	111.77	111.77	74.52	37.26	18.63	
	1	0	0	0	1	104.78	104.78	69.86	34.93	17.46	
	1	0	0	1	0	109.51	109.51	73.01	36.50	18.25	
	1	0	0	1	1	100.90	100.90	67.27	33.63	16.82	
	1	0	1	0	0	117.00	117.00	78.50	39.25	19.63	
	1	0	1	0	1	123.75	123.75	82.50	41.25	20.62	
	1	0	1	1	0	133.33	133.33	88.89	44.44	22.22	
	1	0	1	1	1	142.50	142.50	95.00	47.50	23.75	
	1	1	0	0	0	136.00	102.25	68.50	34.25	17.13	
	1	1	0	0	1	140.00	105.00	70.00	35.00	17.50	
	1	1	0	1	0	143.00	107.50	72.00	36.00	18.00	
1	1	0	1	1	133.90	100.68	67.45	33.73	16.86		
1	1	1	0	0	146.67	110.00	73.33	36.67	18.33		
1	1	1	0	1	149.33	112.00	74.67	37.33	18.67		
1	1	1	1	0	153.30	115.29	77.24	38.62	19.30		
1	1	1	1	1	166.67	125.32	83.34	41.67	20.83		
Bit 3	0-Frequency is selected by hardware select, latched inputs 1- Frequency is selected by Bit 2,6:4										0
Bit 1	0- Normal 1- Spread spectrum enable $\pm 0.25\%$ Center Spread										1
Bit 0	0- Running 1- Tristate all outputs										0

Notes:

1. Default at power-up will be for latched logic inputs to define frequency, as displayed by Bit 3.



Byte 1: Control Register
(1 = enable, 0 = disable)

Bit	Pin#	PWD	Description
Bit 7	-	0	FS3#
Bit 6	-	0	FS0#
Bit 5	-	0	FS2#
Bit 4	35	1	24MHz
Bit 3	-	1	(Reserved)
Bit 2	34	1	48MHz
Bit 1	-	1	(Reserved)
Bit 0	38	1	SDRAM_F

Byte 2: Control Register
(1 = enable, 0 = disable)

Bit	Pin#	PWD	Description
Bit 7	39	1	SDRAM7
Bit 6	40	1	SDRAM6
Bit 5	42	1	SDRAM5
Bit 4	43	1	SDRAM4
Bit 3	44	1	SDRAM3
Bit 2	46	1	SDRAM2
Bit 1	47	1	SDRAM1
Bit 0	48	1	SDRAM0

Byte 3: Control Register
(1 = enable, 0 = disable)

Bit	Pin#	PWD	Description
Bit 7	20	1	PCICLK7
Bit 6	19	1	PCICLK6
Bit 5	17	1	PCICLK5
Bit 4	16	1	PCICLK4
Bit 3	15	1	PCICLK3
Bit 2	13	1	PCICLK2
Bit 1	12	1	PCICLK1
Bit 0	11	1	PCICLK0

Byte 4: Control Register
(1 = enable, 0 = disable)

Bit	Pin#	PWD	Description
Bit 7	-	1	(Reserved)
Bit 6	7	1	3V66_0
Bit 5	8	1	3V66_1
Bit 4	-	0	FS4#
Bit 3	54	1	IOAPIC
Bit 2	-	0	FS1#
Bit 1	51	1	CPUCLK1
Bit 0	52	1	CPUCLK0

Byte 5: Control Register
(1 = enable, 0 = disable)

Bit	Pin#	PWD	Description
Bit 7	-	1	(Reserved)
Bit 6	-	1	(Reserved)
Bit 5	-	1	(Reserved)
Bit 4	-	1	(Reserved)
Bit 3	26	1	SDRAM11
Bit 2	27	1	SDRAM10
Bit 1	30	1	SDRAM9
Bit 0	31	1	SDRAM8

Notes:

1. Inactive means outputs are held LOW and are disabled from switching. These outputs are designed to be configured at power-on and are not expected to be configured during the normal modes of operation.
2. PWD = Power on Default



Absolute Maximum Ratings

Core Supply Voltage	4.6 V
I/O Supply Voltage	3.6V
Logic Inputs	GND -0.5 V to V _{DD} +0.5 V
Ambient Operating Temperature	0°C to +70°C
Storage Temperature	-65°C to +150°C
Case Temperature	115°C

Stresses above those listed under *Absolute Maximum Ratings* may cause permanent damage to the device. These ratings are stress specifications only and functional operation of the device at these or any other conditions above those listed in the operational sections of the specifications is not implied. Exposure to absolute maximum rating conditions for extended periods may affect product reliability.

Group Timing Relationship Table

Group	CPU 66MHz		CPU 100MHz		CPU 133MHz	
	Offset	Tolerance	Offset	Tolerance	Offset	Tolerance
CPU to SDRAM	2.5ns	500ps	5.0ns	500ps	0.0ns	500ps
CPU to 3V66	7.5ns	500ps	5.0ns	500ps	0.0ns	500ps
SDRAM to 3V66	0.0ns	500ps	0.0ns	500ps	0.0ns	500ps
3V66 to PCI	1.5-3.5ns	500ps	1.5-3.5ns	500ps	1.5-3.5ns	500ps
USB & DOT	Asynch	N/A	Asynch	N/A	Asynch	N/A

Electrical Characteristics - Input/Supply/Common Output Parameters

T_A = 0 - 70° C; Supply Voltage V_{DD} = 3.3 V +/-5%, V_{DDL} = 2.5 V +/-5% (unless otherwise stated)

PARAMETER	SYMBOL	CONDITIONS	MIN	TYP	MAX	UNITS
Input High Voltage	V _{IH}		2		V _{DD} +0.3	V
Input Low Voltage	V _{IL}		V _{SS} -0.3		0.8	V
Input High Current	I _{IH}	V _{IN} = V _{DD}	-5		5	μA
Input Low Current	I _{IL1}	V _{IN} = 0 V; Inputs with no pull-up resistors	-5			μA
Input Low Current	I _{IL2}	V _{IN} = 0 V; Inputs with pull-up resistors	-200			μA
Operating Supply Current	I _{DD3.3V}	Cl = 0 pF; Select @ 66M		119	280	mA
	I _{DDL2.5V}	Cl = 0 pF; Select @ 66M		3	25	
Power Down Current	I _{DD3.3VPD}	Cl = 0 pF; With Input to Vdd or Gnd			600	μA
Input frequency	F _i	V _{DD} = 3.3 V		14.318		MHz
Input Capacitance ¹	C _{IN}	Logic Inputs			5	pF
	C _{INX}	X1 & X2 pins	27		45	pF
Transition Time ¹	T _{Trans}	To 1st crossing of target Freq.			3	ms
Settling Time ¹	T _S	From 1st crossing to 1% target Freq.		1	3	ms
Clk Stabilization ¹	T _{Stab}	From V _{DD} = 3.3 V to 1% target Freq.			3	ms
Delay ¹	T _{PZH,TPZL}	output enable delay(all outputs)	1		10	ns
	T _{PHZ,TPLZ}	output disable delay(all outputs)	1		10	ns

¹Guaranteed by design, not 100% tested in production.



ICS9250-23

Electrical Characteristics - IOAPIC

$T_A = 0 - 70^\circ\text{C}$; $V_{DD} = 3.3\text{ V} \pm 5\%$, $V_{DDL} = 2.5\text{ V} \pm 5\%$; $C_L = 20\text{ pF}$ (unless otherwise stated)

PARAMETER	SYMBOL	CONDITIONS
Output High Voltage	V_{OH4B}	$I_{OH} = -18\text{ mA}$
Output Low Voltage	V_{OL4B}	$I_{OL} = 9\text{ mA}$
Output High Current	I_{OH4B}	$V_{OH} = 2.0\text{ V}$
Output Low Current	I_{OL4B}	$V_{OL@MIN} = 1.0\text{ V}$ $V_{OL@MAX} = 0.2\text{ V}$
Rise Time ¹	T_{r4B}	$V_{OL} = 0.4\text{ V}$, $V_{OH} = 2.0\text{ V}$
Fall Time ¹	T_{f4B}	$V_{OH} = 2.0\text{ V}$, $V_{OL} = 0.4\text{ V}$
Duty Cycle ¹	D_{t4B}	$V_T = 1.25\text{ V}$
Jitter, Cycle-to-Cycle	$t_{j\text{cyc-cyc}4B}$	$V_T = 1.25\text{ V}$

¹Guaranteed by design, not 100% tested in production.

Electrical Characteristics - CPULCK

$T_A = 0 - 70^\circ\text{C}$; $V_{DD} = 3.3\text{ V} \pm 5\%$, $V_{DDL} = 2.5\text{ V} \pm 5\%$; $C_L = 20\text{ pF}$ (unless otherwise stated)

PARAMETER	SYMBOL	CONDITIONS
Output High Voltage	V_{OH2B}	$I_{OH} = -1\text{ mA}$
Output Low Voltage	V_{OL2B}	$I_{OL} = 1\text{ mA}$
Output High Current	I_{OH2B}	$V_{OH@MIN} = 1\text{ V}$ $V_{OH@MAX} = 2.375\text{ V}$
Output Low Current	I_{OL2B}	$V_{OL@MIN} = 1.2\text{ V}$ $V_{OL@MAX} = 0.3\text{ V}$
Rise Time	t_{r2B}	$V_{OL} = 1\text{ V}$, $V_{OH} = 2.0\text{ V}$
Fall Time	t_{f2B}	$V_{OH} = 2.0\text{ V}$, $V_{OL} = 0.4\text{ V}$
Duty Cycle	D_{t2B}	$V_T = 1.25\text{ V}$
Skew	t_{sk2B}	$V_T = 1.25\text{ V}$
Jitter, Cycle-to-Cycle	$t_{j\text{cyc-cyc}2B}$	$V_T = 1.25\text{ V}$ (CPS 133, SDRAM 100)
Jitter, Cycle-to-Cycle	$t_{j\text{cyc-cyc}}$	$V_T = 1.25\text{ V}$ (all other select B)

¹Guaranteed by design, not 100% tested in production.



Electrical Characteristics - PCICLK

$T_A = 0 - 70^\circ C$; $V_{DD} = 3.3 V \pm 5\%$, $V_{DDL} = 2.5 V \pm 5\%$; $C_L = 60 pF$ for PCI0 & PCI1, $C_L = 30 pF$ for other PCIs

PARAMETER	SYMBOL	CONDITIONS	MIN	TYP	MAX	UNITS
Output High Voltage	V_{OH1}	$I_{OH} = -1 mA$	2.4	3.25		V
Output Low Voltage	V_{OL1}	$I_{OL} = 1 mA$		0.03	0.55	V
Output High Current	I_{OH1}	$VOH_{@MIN} = 1 V$		-71	-33	mA
		$VOH_{@MAX} = 3.135V$	-33	-10		
Output Low Current	I_{OL1}	$VOL_{@MIN} = 1.95 V$	38	74		mA
		$VOL_{@MAX} = 0.4V$		22	30	
Rise Time ¹	t_{r1}	$V_{OL} = 0.4 V, V_{OH} = 2.4 V$	0.5	1.65	2	ns
Fall Time ¹	t_{f1}	$V_{OH} = 2.4 V, V_{OL} = 0.4 V$	0.5	1.53	2	ns
Duty Cycle ¹	d_{t1}	$V_T = 1.5 V$	45	51.1	55	%
Skew ¹	t_{sk1}	$V_T = 1.5 V$		331	500	ps
Jitter ¹ , Cycle-to-Cycle	$t_{jcc-cyc1}$	$V_T = 1.5 V$		185	500	ps

¹Guaranteed by design, not 100% tested in production.

Electrical Characteristics - 3V66

$T_A = 0 - 70^\circ C$; $V_{DD} = 3.3 V \pm 5\%$, $V_{DDL} = 2.5 V \pm 5\%$; $C_L = 10 - 30 pF$

PARAMETER	SYMBOL	CONDITIONS
Output High Voltage	V_{OH1}	$I_{OH} = -1 mA$
Output Low Voltage	V_{OL1}	$I_{OL} = 1 mA$
Output High Current	I_{OH1}	$VOH_{@MIN} = 1 V$
		$VOH_{@MAX} = 3.135V$
Output Low Current	I_{OL1}	$VOL_{@MIN} = 1.95 V$
		$VOL_{@MAX} = 0.4V$
Rise Time ¹	t_{r1}	$V_{OL} = 0.4 V, V_{OH} = 2.4 V$
Fall Time ¹	t_{f1}	$V_{OH} = 2.4 V, V_{OL} = 0.4 V$
Duty Cycle ¹	d_{t1}	$V_T = 1.5 V$
Skew ¹	t_{sk1}	$V_T = 1.5 V$
Jitter ¹ , Cycle-to-Cycle	$t_{jcc-cyc1}$	$V_T = 1.5 V$

¹Guaranteed by design, not 100% tested in production.



ICS9250-23

Electrical Characteristics 48MHz REF

$T_A = 0 - 70^\circ\text{C}$; $V_{DD} = 3.3\text{V} \pm 5\%$, $V_{DDL} = 2.5\text{V} \pm 5\%$; $C_{LL} = 20\text{pF}$ (unless

PARAMETER	SYMBOL	CONDITIONS
Output High Voltage	V_{OH5}	$I_{OH} = -1\text{mA}$
Output Low Voltage	V_{OL5}	$I_{OL} = 1\text{mA}$
Output High Current	I_{OH5}	$V_{OH@MIN} = 1\text{V}$ $V_{OH@MAX} = 3.135\text{V}$
Output Low Current	I_{OL5}	$V_{OL@MIN} = 1.95\text{V}$ $V_{OL@MAX} = 0.4\text{V}$
Rise Time ¹	t_{r5}	$V_{OL} = 0.4\text{V}$, $V_{OH} = 2.4\text{V}$
Fall Time ¹	t_{f5}	$V_{OH} = 2.4\text{V}$, $V_{OL} = 0.4\text{V}$
Duty Cycle ¹	dl_{t5}	$V_T = 1.5\text{V}$
Jitter ¹ , Cycle-to-Cycle	$t_{jxc-cyc5}$	$V_T = 1.5\text{V}$, 24MHz
Jitter ¹ , Cycle-to-Cycle	$t_{jcc-cyc5}$	$V_T = 1.5\text{V}$, 48MHz
Jitter ¹ , Cycle-to-Cycle	$t_{jcc-cyc5}$	$V_T = 1.5\text{V}$, REF

¹Guaranteed by design, not 100% tested in production.



Electrical Characteristics - SDRAM

T_A = 0 - 70° C; V_{DD} = 3.3 V +/-5%, V_{DDL} = 2.5 V +/-5%; C_L =30 pF

PARAMETER	SYMBOL	CONDITIONS	MIN	TYP	MAX	UNITS
Output High Voltage	V _{OH1}	I _{OH} = -1 mA	2.4	3.28		V
Output Low Voltage	V _{OL1}	I _{OL} = 1 mA		0.03	0.4	V
Output High Current	I _{OH1}	VOH@MIN = 2 V		-85	-54	mA
		VOH@MAX = 3.135V	-46	-12		
Output Low Current	I _{OL1}	VOL@MIN = 1 V	54	63		mA
		VOL@MAX =0.4V		27	53	
Rise Time ¹	t _{r1}	V _{OL} = 0.4 V, V _{OH} = 2.4 V	0.4	1.25	1.6	ns
Fall Time ¹	t _{f1}	V _{OH} = 2.4 V, V _{OL} = 0.4 V	0.4	1.53	1.6	ns
Duty Cycle ¹	d _{t1}	V _T = 1.5 V	45	53.2	55	%
Skew	t _{sk1}	V _T = 1.5 V		267	380	ps
Jitter ¹ , Cycle-to-Cycle	t _{jycyc-cycl}	V _T = 1.5 V		176	250	ps

¹Guaranteed by design, not 100% tested in production.

(No Skew Window is needed for Group Skew spec.)

T_A = 0 - 70° C; V_{DD} = 3.3 V +/-5%, V_{DDL} = 2.5 V +/-5%

24MHz, 48MHz, REF, CPU & IOAPIC load = 20 pF; PCI, SDRAM & 3V66 load = 30 pF.

Refer to Group Offset Waveform diagram for definition of transition edges.

Group Skews (CPU = 66 MHz; SDRAM = 100MHz)

PARAMETER	SYMBOL	CONDITIONS	MIN	TYP	MAX	UNITS	
CPU to SDRAM	Skew ¹	T _{sk1} CPU-SDRAM	CPU @ 1.25 V, SDRAM @ 1.5 V	2.0		3.0	ns
CPU to 3V66	Skew ¹	T _{sk1} CPU-3V66	CPU @ 1.25 V, 3V66 @ 1.5 V	7		8	ns
SDRAM to 3V66	Skew ¹	T _{sk1} SDRAM-3V66	SDRAM @ 1.5V, 3V66 @ 1.5 V	-500	394	500	ps
3V66 to PCI	Skew ¹	T _{sk1} 3V66-PCI	3V66 @ 1.5V, PCI @ 1.5 V	1.5	2.58	3.5	ns

Group Skews (CPU = 100 MHz; SDRAM = 100MHz)

PARAMETER	SYMBOL	CONDITIONS	MIN	TYP	MAX	UNITS	
CPU to SDRAM	Skew ¹	T _{sk1} CPU-SDRAM	CPU @ 1.25 V, SDRAM @ 1.5 V	4.5		5.5	ns
CPU to 3V66	Skew ¹	T _{sk1} CPU-3V66	CPU @ 1.25 V, 3V66 @ 1.5 V	4.5	4.63	5.5	ns
SDRAM to 3V66	Skew ¹	T _{sk1} SDRAM-3V66	SDRAM @ 1.5V, 3V66 @ 1.5 V	-500	396	500	ps
3V66 to PCI	Skew ¹	T _{sk1} 3V66-PCI	3V66 @ 1.5V, PCI @ 1.5 V	1.5	2.58	3.5	ns

Group Skews (CPU = 133 MHz; SDRAM = 100MHz)

PARAMETER	SYMBOL	CONDITIONS	MIN	TYP	MAX	UNITS	
CPU to SDRAM	Skew ¹	T _{sk1} CPU-SDRAM	CPU @ 1.25 V, SDRAM @ 1.5 V	-500	-322	500	ps
CPU to 3V66	Skew ¹	T _{sk1} CPU-3V66	CPU @ 1.25 V, 3V66 @ 1.5 V	-500	-284	500	ps
SDRAM to 3V66	Skew ¹	T _{sk1} SDRAM-3V66	SDRAM @ 1.5V, 3V66 @ 1.5 V	-500	389	500	ps
3V66 to PCI	Skew ¹	T _{sk1} 3V66-PCI	3V66 @ 1.5V, PCI @ 1.5 V	1.5	2.61	3.5	ns

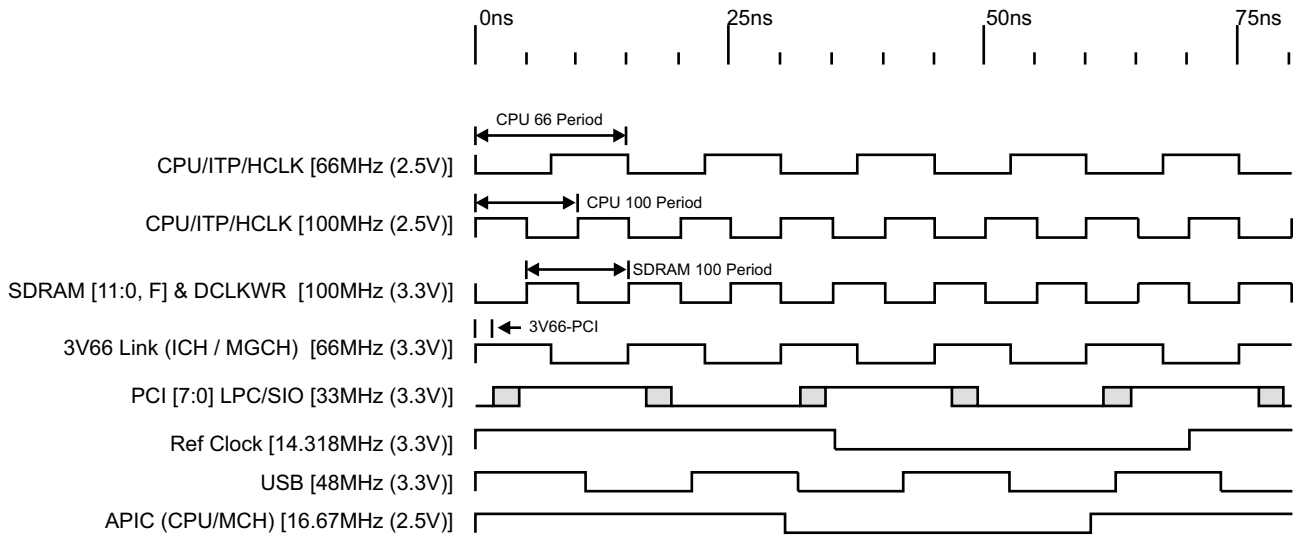

Group Offset Waveforms

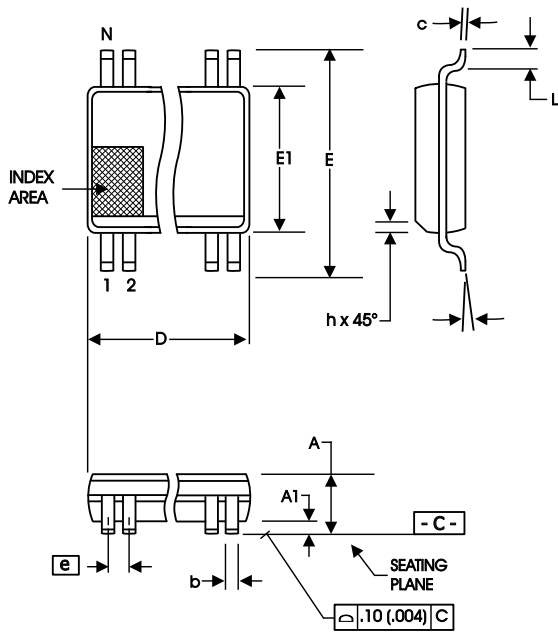

300 mil SSOP Package

SYMBOL	In Millimeters		In Inches	
	COMMON DIMENSIONS		COMMON DIMENSIONS	
	MIN	MAX	MIN	MAX
A	2.41	2.80	.095	.110
A1	0.20	0.40	.008	.016
b	0.20	0.34	.008	.0135
c	0.13	0.25	.005	.010
D	SEE VARIATIONS		SEE VARIATIONS	
E	10.03	10.68	.395	.420
E1	7.40	7.60	.291	.299
e	0.635 BASIC		0.025 BASIC	
h	0.38	0.64	.015	.025
L	0.50	1.02	.020	.040
N	SEE VARIATIONS		SEE VARIATIONS	
α	0°	8°	0°	8°

VARIATIONS

N	D mm.		D (inch)	
	MIN	MAX	MIN	MAX
56	18.31	18.55	.720	.730

Reference Doc.: JEDEC Publication 95, MO-118

10-0034

Ordering Information

ICS9250yF-23

Example:

ICS XXXX y F - PPP

