



**Integrated  
Circuit  
Systems, Inc.**

**ICS93718**

## DDR and SDRAM Buffer

### Recommended Application:

DDR & SDRAM fanout buffer, for VIA Pro 266, KT266 and P4X266 DDR chipsets

### Product Description/Features:

- Low skew, fanout buffer
- 1 to 12 differential clock distribution
- I<sup>2</sup>C for functional and output control
- Feedback pin for input to output synchronization
- Supports up to 4 DDR DIMMs or 3 SDRAM DIMMs + 2 DDR DIMMs
- Frequency supports up to 200MHz (DDR400)
- Supports Power Down Mode for power management
- CMOS level control signal input

### Switching Characteristics:

- OUTPUT - OUTPUT skew: <100ps
- Output Rise and Fall Time for DDR outputs: 500ps - 700ps
- DUTY CYCLE: 47% - 53%

### Pin Configuration

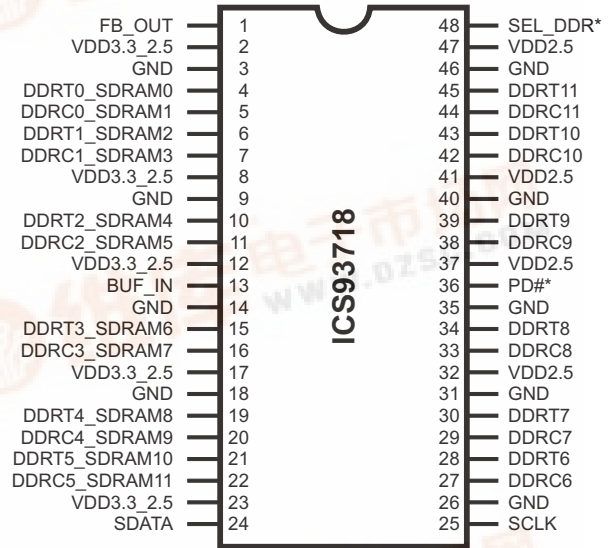

### 48-Pin SSOP

\*Internal Pull-up Resistor of 120K to VDD

### Block Diagram

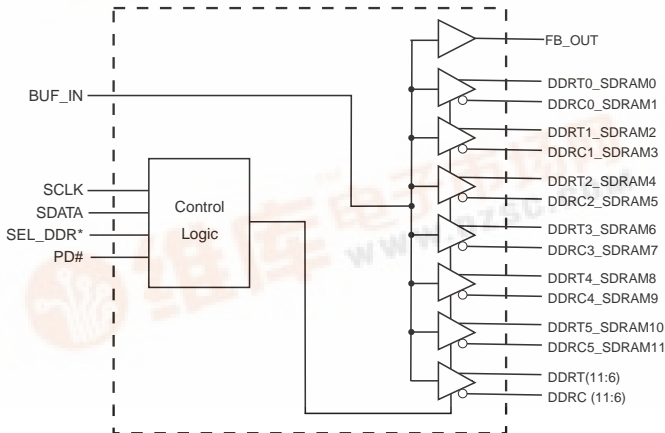

### Functionality

MODE	PIN 48	VDD 3.3_2.5	PIN 4, 5, 6, 7, 10, 11, 15, 16, 19, 20, 21, 22
DDR Mode	SEL_DDR=1	2.5V	These outputs will be DDR outputs
DDR/SD Mode	SEL_DDR=0	3.3V	These outputs will be standard SDRAM outputs



## Pin Descriptions

PIN NUMBER	PIN NAME	TYPE	DESCRIPTION
1	FB_OUT	OUT	Feedback output, dedicated for external feedback
2, 8, 12, 17, 23,	VDD3.3_2.5	PWR	2.5V or 3.3V voltage supply to pins 4, 5, 6, 7, 10, 11, 15, 16, 19, 20, 21, 22
3, 9, 14, 18, 26, 31, 35, 40, 46	GND	PWR	Ground
45, 43, 39, 34, 30, 28,	DDRT (11:6)	OUT	"True" Clock of differential pair outputs.
44, 42, 38, 33, 29, 27,	DDRC (11:6)	OUT	"Complementary" clocks of differential pair outputs.
21, 19, 15, 10, 6, 4	DDRT (5:0) SDRAM (10, 8, 6, 4, 2, 0)	OUT	"True" Clock of differential pair outputs, or 3.3V SDRAM clock outputs depending on SEL_DDR input
22, 20, 16, 11, 7, 5	DDRC (5:0) SDRAM (11, 9, 7, 5, 3, 1,)	OUT	"Complementary" clocks of differential pair outputs, or 3.3V SDRAM clock outputs depending on SEL_DDR input
13	BUF_IN	IN	Single ended buffer input
24	SDATA	I/O	Data pin for I <sup>2</sup> C circuitry 5V tolerant
25	SCLK	IN	Clock input of I <sup>2</sup> C input, 5V tolerant input
32, 37, 41, 47	VDD2.5	PWR	2.5V voltage supply
36	PD#	IN	Asynchronous active low input pin used to power down the device into a low power state. The internal clocks are disabled. The latency of the power down will not be greater than 3ms.
48	SEL_DDR	IN	Select input for DDR mode or DDR/SD mode 0=DDR/SD mode 1=DDR mode



**Byte 6: Output Control**  
(1= enable, 0 = disable)

BIT	PIN#	PWD	DESCRIPTION
Bit 7	48	1	SEL_DDR (Read back only)
Bit 6	-	1	(Reserved)
Bit 5	-	1	(Reserved)
Bit 4	-	1	(Reserved)
Bit 3	45, 44	1	DDRT11, DDRC11
Bit 2	43, 42	1	DDRT10, DDRC10
Bit 1	39, 38	1	DDRT9, DDRC9
Bit 0	34, 33	1	DDRT8, DDRC8

**Byte 7: Output Control**  
(1= enable, 0 = disable)

BIT	PIN#	PWD	DESCRIPTION
Bit 7	30, 29	1	DDRT7, DDRC7
Bit 6	28, 27	1	DDRT6, DDRC6
Bit 5	21, 22	1	DDRT5, SDRAM10 DDRC5_SDRAM11
Bit 4	19, 20	1	DDRT4_SDRAM8 DDRC4_SDRAM9
Bit 3	15, 16	1	DDRT3_SDRAM6 DDRC3_SDRAM7
Bit 2	10, 11	1	DDRT2_SDRAM4 DDRC2_SDRAM5
Bit 1	6, 7	1	DDRT1_SDRAM2 DDRC1_SDRAM3
Bit 0	4, 5	1	DDRT0_SDRAM1 DDRC0_SDRAM0



## Absolute Maximum Ratings

Supply Voltage (VDD & VDD2.5)	-0.5V to 3.6V
Logic Inputs	GND -0.5 V to V <sub>DD</sub> +0.5 V
Ambient Operating Temperature	0°C to +85°C
Case Temperature	115°C
Storage Temperature	-65°C to +150°C

Stresses above those listed under *Absolute Maximum Ratings* may cause permanent damage to the device. These ratings are stress specifications only and functional operation of the device at these or any other conditions above those listed in the operational sections of the specifications is not implied. Exposure to absolute maximum rating conditions for extended periods may affect product reliability.

## Electrical Characteristics - Input/Supply/Common Output Parameters

SEL\_DDR = 0 SDRAM Outputs V<sub>DD</sub> = 3.3V, T<sub>A</sub> = 0 - 85°C; (unless otherwise stated)

PARAMETER	SYMBOL	CONDITIONS	MIN	TYP	MAX	UNITS
Input High Current	I <sub>IH</sub>	V <sub>I</sub> = V <sub>DD</sub> or GND		1	10	μA
Input Low Current	I <sub>IL</sub>	V <sub>I</sub> = V <sub>DD</sub> or GND	-100	-20		μA
Operating Supply Current	I <sub>DD3.3 2.5</sub>	C <sub>L</sub> = 0pf, 133MHz		200	250	mA
	I <sub>DD2.5</sub>	C <sub>L</sub> = 0pf, 133MHz		100	200	mA
	I <sub>DDPD</sub>	C <sub>L</sub> = 0pf, all frequencies		3	10	mA
Output High Current	I <sub>OH</sub>	V <sub>DD</sub> = 3.3V, V <sub>OUT</sub> = 1V		-74	-18	mA
Output Low Current	I <sub>OL</sub>	V <sub>DD</sub> = 3.3V, V <sub>OUT</sub> = 1.2V	26	42		mA
High-level output voltage	V <sub>OH</sub>	V <sub>DD</sub> = 3.3V, V <sub>OH</sub> = -12mA	2	2.95		V
		V <sub>DD</sub> = 3.3V I <sub>OH</sub> = 12mA		0.35	0.4	
Low-level output voltage	V <sub>OL</sub>	V <sub>DD</sub> = 3.3V I <sub>OH</sub> = 12mA				
Input Capacitance <sup>1</sup>	C <sub>IN</sub>	V <sub>I</sub> = GND or V <sub>DD</sub>		2		pF

<sup>1</sup>Guaranteed by design, not 100% tested in production.

## Recommended Operating Condition

SEL\_DDR=0 SDRAM Outputs V<sub>DD</sub>=3.3V, T<sub>A</sub> = 0 - 85°C; (unless otherwise stated)

PARAMETER	SYMBOL	CONDITIONS	MIN	TYP	MAX	UNITS
Power Supply Voltage	V <sub>DD3.3 2.5</sub>		3.0	3.3	3.6	V
	V <sub>DD2.5</sub>		2.3	2.5	2.7	
Input High Voltage	V <sub>IH</sub>	SEL_DDR, PD# input	2.0			V
Input Low Voltage	V <sub>IL</sub>	SEL_DDR, PD# input			0.8	V
Input voltage level	V <sub>IN</sub>			V <sub>DD</sub>		V

<sup>1</sup>Guaranteed by design, not 100% tested in production.



**Electrical Characteristics - Input/Supply/Common Output Parameters**

SEL\_DDR = 1 DDR/DDR\_SDRAM Outputs  $V_{DD}=2.5$ ,  $T_A = 0 - 85^{\circ}\text{C}$ ; (unless otherwise stated)

PARAMETER	SYMBOL	CONDITIONS	MIN	TYP	MAX	UNITS
Input High Current	$I_{IH}$	$V_I = V_{DD}$ or GND		1	10	$\mu\text{A}$
Input Low Current	$I_{IL}$	$V_I = V_{DD}$ or GND	-100	-25		$\mu\text{A}$
Operating Supply Current	$I_{DD2.5}$	$C_L = 0\text{pf}$ , 133MHz		76	200	mA
	$I_{DDPD}$	$C_L = 0\text{pf}$ , all frequencies		3	10	mA
Output High Current	$I_{OH}$	$V_{DD} = 2.5\text{V}$ , $V_{OUT} = 1\text{V}$		-74.5	-18	mA
Output Low Current	$I_{OL}$	$V_{DD} = 2.5\text{V}$ , $V_{OUT} = 1.2\text{V}$	26	42.5		mA
High-level output voltage	$V_{OH}$	$V_{DD} = 2.5\text{V}$ , $V_{OH} = -12\text{mA}$	1.7	2.3		V
		$V_{DD} = 2.5\text{V}$ , $I_{OH} = 12\text{mA}$		0.35	0.46	
Low-level output voltage	$V_{OL}$					
Output differential-pair crossing voltage	$V_{OC}$		$(V_{DD}/2) - 0.1$	1.25	$(V_{DD}/2) + 0.1$	V
Input Capacitance <sup>1</sup>	$C_{IN}$	$V_I = \text{GND}$ or $V_{DD}$		2		pF

<sup>1</sup>Guaranteed by design, not 100% tested in production.

**Recommended Operating Condition**

SEL\_DDR=1 DDR/DDR\_SDRAM Outputs = 2.5V,  $T_A = 0 - 85^{\circ}\text{C}$  (unless otherwise stated)

PARAMETER	SYMBOL	CONDITIONS	MIN	TYP	MAX	UNITS
Power Supply Voltage	$V_{DD3.3\ 2.5}$		2.3	2.5	2.7	V
	$V_{DD2.5}$		2.3	2.5	2.7	
Input High Voltage	$V_{IH}$	SEL_DDR, PD# input	2.0			V
Input Low Voltage	$V_{IL}$	SEL_DDR, PD# input			0.8	V
Input voltage level	$V_{IN}$			$V_{DD}$		V

<sup>1</sup>Guaranteed by design, not 100% tested in production.



## Switching Characteristics

DDR\_Mode (SEL\_DDR = 1), VDD = 2.5±5%

PARAMETER	SYMBOL	CONDITION	MIN	TYP	MAX	UNITS
Operating Frequency			66	133	200	MHz
Input clock duty cycle	$d_{tin}$		40	50	60	%
Output to Output Skew	$T_{skew}$	Output crossover skew DDR[0:11]		80	100	ps
Duty cycle	$D_C^2$	66MHz to 100MHz, w/loads	48	49	52	%
		101MHz to 167MHz, w/loads	47	50	53	%
Rise Time, Fall Time (DDR Outputs)	trd, tfd	Measured between 20% and 80% output, w/loads	500	600	700	ps

## Switching Characteristics

SD\_Mode (SEL\_DDR = 0), VDD = 3.3±5%

PARAMETER	SYMBOL	CONDITION	MIN	TYP	MAX	UNITS
Operating Frequency			66	133	200	MHz
Input clock duty cycle	$d_{tin}$		40	50	60	%
Output to Output Skew	$T_{skew}$	$V_T = 1.50V$		150		ps
Duty cycle	$D_C^2$	66MHz to 200MHz		54		%
Rise Time, Fall Time (SDRAM Outputs)	trs, tfs	$V_{OL} = 0.4V, V_{OH} = 2.4V, w/loads$	0.5	1.5	1.7	ns
SDRAM Buffer LH Prop. Delay <sup>1</sup>	$t^{PLH}$	Input edge greater than 1V/ns		2	2.5	ns
SDRAM Buffer HL Prop. Delay <sup>1</sup>	$t^{PHL}$	Input edge greater than 1V/ns		1.9	2.5	ns

### Notes:

1. Refers to transition on non-inverting output.
2. While the pulse skew is almost constant over frequency, the duty cycle error increases at higher frequencies. This is due to the formula: duty cycle= $t_2/t_1$ , were the cycle ( $t_1$ ) decreases as the frequency goes up.

## Switching Waveforms

### Duty Cycle Timing

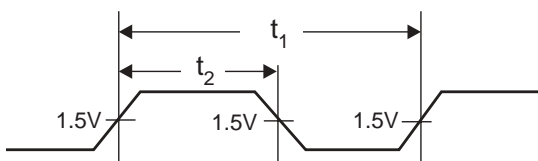

### SDRAM Buffer LH and HL Propagation Delay

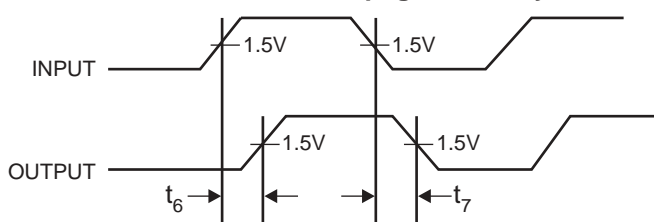



## General I<sup>2</sup>C serial interface information

The information in this section assumes familiarity with I<sup>2</sup>C programming.  
For more information, contact ICS for an I<sup>2</sup>C programming application note.

### How to Write:

- Controller (host) sends a start bit.
- Controller (host) sends the write address D2<sub>(H)</sub>
- ICS clock will **acknowledge**
- Controller (host) sends a dummy command code
- ICS clock will **acknowledge**
- Controller (host) sends a dummy byte count
- ICS clock will **acknowledge**
- Controller (host) starts sending first byte (Byte 0) through byte 6
- ICS clock will **acknowledge** each byte *one at a time*.
- Controller (host) sends a Stop bit

How to Write:	
Controller (Host)	ICS (Slave/Receiver)
Start Bit	
Address D2 <sub>(H)</sub>	
	<b>ACK</b>
Dummy Command Code	
	<b>ACK</b>
Dummy Byte Count	
	<b>ACK</b>
Byte 0	
	<b>ACK</b>
Byte 1	
	<b>ACK</b>
Byte 2	
	<b>ACK</b>
Byte 3	
	<b>ACK</b>
Byte 4	
	<b>ACK</b>
Byte 5	
	<b>ACK</b>
Byte 6	
	<b>ACK</b>
Byte 7	
	<b>ACK</b>
Stop Bit	

### How to Read:

- Controller (host) will send start bit.
- Controller (host) sends the read address D3<sub>(H)</sub>
- ICS clock will **acknowledge**
- ICS clock will send the **byte count**
- Controller (host) acknowledges
- ICS clock sends first byte (**Byte 0**) through **byte 7**
- Controller (host) will need to acknowledge each byte
- Controller (host) will send a stop bit

How to Read:	
Controller (Host)	ICS (Slave/Receiver)
Start Bit	
Address D3 <sub>(H)</sub>	
	<b>ACK</b>
	<b>Byte Count</b>
ACK	
	<b>Byte 0</b>
ACK	
	<b>Byte 1</b>
ACK	
	<b>Byte 2</b>
ACK	
	<b>Byte 3</b>
ACK	
	<b>Byte 4</b>
ACK	
	<b>Byte 5</b>
ACK	
	<b>Byte 6</b>
ACK	
	<b>Byte 7</b>
Stop Bit	

### Notes:

1. The ICS clock generator is a slave/receiver, I<sup>2</sup>C component. It can read back the data stored in the latches for verification. **Read-Back will support Intel PIIX4 "Block-Read" protocol.**
2. The data transfer rate supported by this clock generator is 100K bits/sec or less (standard mode)
3. The input is operating at 3.3V logic levels.
4. The data byte format is 8 bit bytes.
5. To simplify the clock generator I<sup>2</sup>C interface, the protocol is set to use only "**Block-Writes**" from the controller. The bytes must be accessed in sequential order from lowest to highest byte with the ability to stop after any complete byte has been transferred. The Command code and Byte count shown above must be sent, but the data is ignored for those two bytes. The data is loaded until a Stop sequence is issued.
6. At power-on, all registers are set to a default condition, as shown.

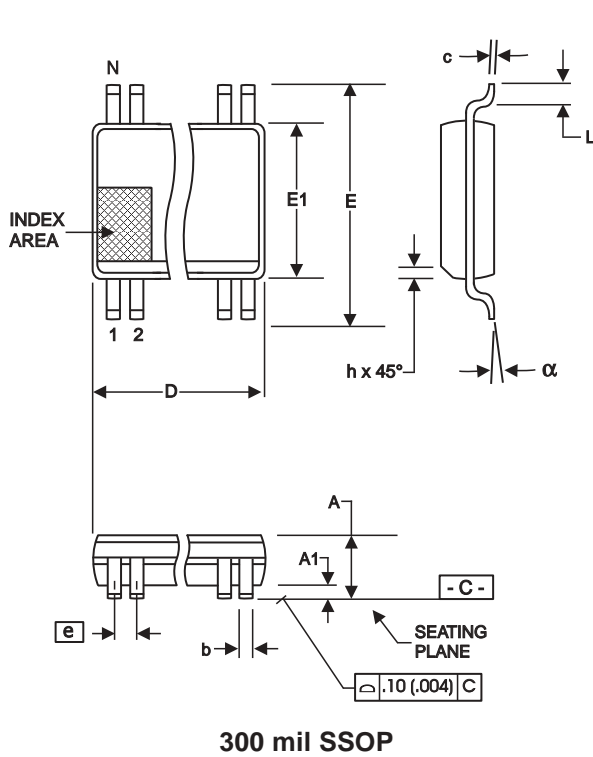

**300 mil SSOP**

SYMBOL	In Millimeters COMMON DIMENSIONS		In Inches COMMON DIMENSIONS	
	MIN	MAX	MIN	MAX
A	2.41	2.80	.095	.110
A1	0.20	0.40	.008	.016
b	0.20	0.34	.008	.0135
c	0.13	0.25	.005	.010
D	SEE VARIATIONS		SEE VARIATIONS	
E	10.03	10.68	.395	.420
E1	7.40	7.60	.291	.299
e	0.635 BASIC		0.025 BASIC	
h	0.38	0.64	.015	.025
L	0.50	1.02	.020	.040
N	SEE VARIATIONS		SEE VARIATIONS	
α	0°	8°	0°	8°

**VARIATIONS**

N	D mm.		D (inch)	
	MIN	MAX	MIN	MAX
48	15.75	16.00	.620	.630

Reference Doc.: JEDEC Publication 95, MO-118

10-0034

## Ordering Information

**ICS93718yFT**

Example:

**ICS XXXX y F - T**

