

TOSHIBA CMOS Digital Integrated Circuit Silicon Monolithic

TC94A14F, TC94A14FA, TC94A14FB

Digital Servo Single-Chip Processor for Use in CD Player

TC94A14F/FA/FB is a single-chip processor which incorporates the following functions: sync separation protection, interpolation, EFM decoder, error correction, micro controller interface, digital equalizer for use in servo LSI, and servo control circuit.

TC94A14F/FA/FB also incorporates a 1-bit DA converter.

Combining TC94A14F/FA/FB with digital servo head amp TA2157F/FN enables very simple and completely adjustment-free CD player systems.

Features

- Capable of decoding the text data.
- Sync pattern detection, sync signal protection, and synchronization can be made correctly.
- Built-in EFM demodulation circuit and sub code demodulation.
- Capable of correcting dual C1 correction and quadruple C2 correction using the CIRC correction theoretical format.
- The TC94A14F/FA/FB respond to variable playback system.
- Jitter absorbing capacity of ± 6 frame.
- Built-in 16 KB RAM.
- Built-in digital out circuit.
- Built-in L/R independent digital attenuator.
- Audio output responds to bilingual function.
- Output format for audio out can be selected 32fs, 48fs or 64fs modes.
- Read-timing-free sub code Q data and capable of synchronous output with audio data.
- Built-in data slicer and analog PLL (adjustment-free VCO).
- Capable of automatic adjustment function of focus and tracking servos for loop gain, offset and balance.
- Built-in RF gain automatic adjustment circuit.
- Built-in digital equalizer for phase compensation.
- Built-in RAM for digital equalizer for coefficient, and capable of variable pickup.
- Built-in focus and tracking servo control circuit.
- Search control corresponds to every mode and can realize high speed and stable search.
- Lens-kick and feed-kick are using speed-controlled form.
- Built-in AFC and APC circuits for CLV servo of disc motor.
- Built-in anti-defect and anti-shock circuit.
- Built-in 8 times over sampling digital filter and 1-bit DA converter.
- Built-in analog filter for 1-bit DA converter.
- Built-in zero data detection output circuit.
- The TC94A14F/FA capable of 4 times speed operation.
- Built-in micro controller interface circuit.
- CMOS silicon structure and high speed, low power consumption.
- 64-pin flat package.

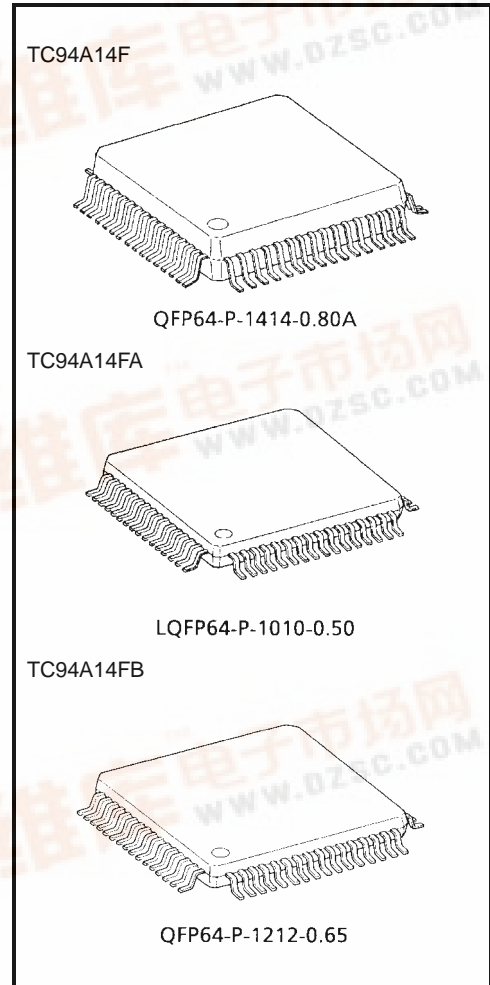

Weight
 QFP64-P-1414-0.80A: 0.5 g (typ.)
 LQFP64-P-1010-0.50: 0.4 g (typ.)
 QFP64-P-1212-0.65: 0.45 g (typ.)



Block Diagram (top view)

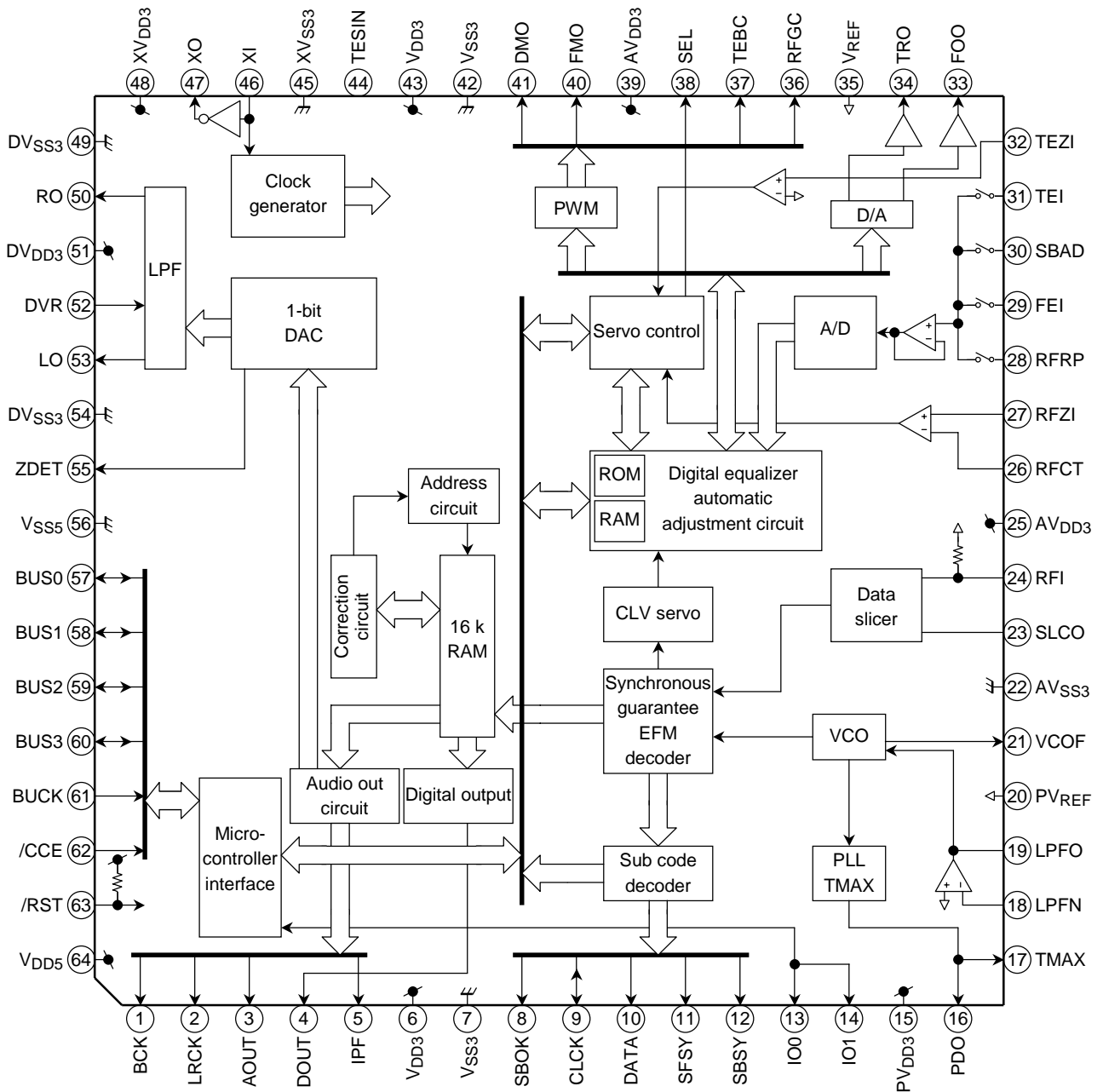

Pin Functions

Pin No.	Symbol	I/O	Function Description	Remarks								
1	BCK	O 3-5I/F	Bit clock output pin. 32fs, 48fs, or 64fs selectable by command.	Normal speed: 32fs = 1.4112 MHz								
2	LRCK	O 3-5I/F	L/R channel clock output pin. "L" for L channel and "H" for R channel. Output polarity can be inverted by command.	Normal speed: 44.1 kHz								
3	AOUT	O 3-5I/F	Audio data output pin. MSB-first or LSB-first selectable by command.	—								
4	DOUT	O 3-5I/F	Digital data output pin. Outputs up to double-speed playback.	Based on CP-1201								
5	IPF	O 3-5I/F	Correction flag output pin. When set to "H", AOUT output cannot be corrected by C2 correction processing.	Alias: C2PO								
6	V _{DD3}	—	Digital 3.3 V power supply voltage pin.	—								
7	V _{SS3}	—	Digital GND pin.	—								
8	SBOK	O 3-5I/F	Subcode Q data CRCC result output pin. "H" level when result is OK.	—								
9	CLCK	I/O 3-5I/F	Subcode P-W data read clock I/O pin. I/O polarity selectable by command.	Schmitt input								
10	DATA	O 3-5I/F	Subcode P-W data output pin.	—								
11	SFSY	O 3-5I/F	Playback frame sync signal output pin.	—								
12	SBSY	O 3-5I/F	Subcode block sync signal output pin. "H" level at S1 when subcode sync is detected.	—								
13	IO0	I/O 3-5I/F	General-purpose input / output pins. Input port at reset.	Schmitt at input								
14	IO1											
15	PV _{DD3}	—	PLL-only 3.3 V power supply voltage pin.	—								
16	PDO	O AI/F	EFM and PLCK phase difference signal output pin.	4-state output (PV _{DD3} , HiZ, PV _{REF} , AV _{SS3})								
17	TMAX	O AI/F	<p>TMAX detection result output pin.</p> <table border="1" style="margin-left: auto; margin-right: auto;"> <thead> <tr> <th>TMAX Detection Result</th> <th>TMAX Output</th> </tr> </thead> <tbody> <tr> <td>Longer than fixed period</td> <td>"PV_{DD3}"</td> </tr> <tr> <td>Within fixed period</td> <td>"HiZ"</td> </tr> <tr> <td>Shorter than fixed period</td> <td>"AV_{SS3}"</td> </tr> </tbody> </table>	TMAX Detection Result	TMAX Output	Longer than fixed period	"PV _{DD3} "	Within fixed period	"HiZ"	Shorter than fixed period	"AV _{SS3} "	3-state output (PV _{DD3} , HiZ, AV _{SS3})
TMAX Detection Result	TMAX Output											
Longer than fixed period	"PV _{DD3} "											
Within fixed period	"HiZ"											
Shorter than fixed period	"AV _{SS3} "											
18	LPFN	I AI/F	Inverted input pin for PLL LPF amp.	Analog input								
19	LPFO	O AI/F	Output pin for PLL LPF amp.	Analog output								
20	PV _{REF}	—	PLL-only V _{REF} pin.	—								
21	VCOF	O AI/F	VCO filter pin.	Analog output								
22	AV _{SS3}	—	Analog GND pin.	—								
23	SLCO	O AI/F	DAC output pin for data slice level generation.	Analog output								
24	RFI	I AI/F	RF signal input pin. Zin selectable by command.	Analog input								
25	AV _{DD3}	—	Analog 3.3 V power supply voltage pin.	—								

Pin No.	Symbol	I/O	Function Description	Remarks
26	RFCT	I AI/F	RFRP signal center level input pin.	Analog input: Zin = 33 kΩ
27	RFZI	I AI/F	RFRP signal zero-cross input pin.	Analog input
28	RFRP	I AI/F	RF ripple signal input pin.	Analog input
29	FEI	I AI/F	Focus error signal input pin.	Analog input
30	SBAD	I AI/F	Sub-beam adder signal input pin.	Analog input
31	TEI	I AI/F	Tracking error input pin. Inputs when tracking servo is on.	Analog input
32	TEZI	I AI/F	Tracking error signal zero-cross input pin.	Analog input: Zin = 10 kΩ
33	FOO	O AI/F	Focus equalizer output pin.	Analog output (AVSS3~AVDD3)
34	TRO	O AI/F	Tracking equalizer output pin.	
35	VREF	—	Analog reference power supply voltage pin.	—
36	RFGC	O AI/F	RF amplitude adjustment control signal output pin.	3-state output (PWM carrier = 88.2 kHz) (AVDD3, VREF, AVSS3)
37	TEBC	O AI/F	Tracking balance control signal output pin.	
38	SEL	O AI/F	APC circuit ON/OFF signal output pin. At laser on, high impedance with UHS = "L", H output with UHS = "H".	3-state output
39	AVDD3	—	Analog 3.3 V power supply voltage pin.	—
40	FMO	O AI/F	Feed equalizer output pin.	3-state output (PWM carrier = 88.2 kHz) (AVDD3, VREF, AVSS3)
41	DMO	O AI/F	Disc equalizer output pin.	
42	VSS3	—	Digital GND pin.	—
43	VDD3	—	Digital 3.3 V power supply voltage pin.	—
44	TESIN	I 3I/F	Test input pin. Normally, fixed to "L".	—
45	XVSS3	—	System clock oscillator GND pin.	—
46	XI	I AI/F	System clock oscillator input pin.	—
47	XO	O AI/F	System clock oscillator output pin.	—
48	XVDD3	—	System clock oscillator 3.3 V power supply voltage pin.	—
49	DVSS3	—	DA converter GND pin.	—
50	RO	O AI/F	R-channel data forward output pin.	—
51	DVDD3	—	DA converter 3.3 V power supply pin.	—
52	DVR	—	Reference voltage pin.	—
53	LO	O AI/F	L-channel data forward output pin.	—
54	DVSS3	—	DA converter GND pin.	—

Pin No.	Symbol	I/O	Function Description	Remarks
55	ZDET	O 3-5I/F	1 bit DA converter zero data detection flag output pin.	—
56	V _{SS5}	—	Microcontroller interface GND pin.	—
57	BUS0	I/O 3-5I/F	Microcontroller interface data I/O pins.	Schmitt input CMOS ports
58	BUS1			
59	BUS2			
60	BUS3			
61	BUCK	I 3-5I/F	Microcontroller interface clock input pin.	Schmitt input
62	/CCE	I 3-5I/F	Microcontroller interface chip enable signal input pin. At "L", BUS0 to BUS3 are active.	Schmitt input
63	/RST	I 3-5I/F	Reset signal input pin. At reset, "L".	Built-in pull-up resistor
64	V _{DD5}	—	Microcontroller interface 5 V power supply pin.	—

Note: AI/F: analog input/output pin
 3-5I/F: 3-5 interface built-in pin (5 V input/output pin)
 3I/F: 3 V input/output pin

Maximum Ratings (unless otherwise specified, GND reference, Ta = 25°C)

Characteristics	Symbol	Rating	Unit	Remarks
Power supply voltage	V _{DD5}	-0.3~6.0	V	64-56 pin
	V _{DD3}	-0.3~4.5		6-7 pin 15, 25, 39-22 pin 43-42 pin 48-45 pin 51-49, 54 pin
Input voltage	V _{IN5}	-0.3~V _{DD5} + 0.3	V	9, 13, 14, 57~63 pin
	V _{IN3}	-0.3~V _{DD3} + 0.3		18, 24, 26~32, 44 pin
Power dissipation	P _D	1910	mW	TC94A14F
		1000		TC94A14FA
		1310		TC94A14FB
Operating temperature	T _{opr}	-40~+85	°C	—
Storage temperature	T _{stg}	-55~+150	°C	—

Electrical Characteristics

DC Characteristics (1)

(unless otherwise specified, $V_{DD5} = 5\text{ V}$, $V_{DD3} = AV_{DD3} = DV_{DD3} = XV_{DD3} = PV_{DD3} = 3.3\text{ V}$, $T_a = 25^\circ\text{C}$)

Characteristics		Symbol	Test Circuit	Test Condition	Min	Typ.	Max	Unit	
Operating power supply voltage		V_{DD5}	—	—	4.5	5.0	5.5	V	
		V_{DD3}	—	—	3.0	3.3	3.6		
		AV_{DD3}	—	—					
		DV_{DD3}	—	—					
		XV_{DD3}	—	—					
		PV_{DD3}	—	—					
Operating power supply current		Normal speed	I_{DD5} (1)	XI = 16.9344 MHz	—	2	5	mA	
			I_{DD3} (1)		—	30	50		
		Double speed	I_{DD5} (2)		—	—	2.5		6
			I_{DD3} (2)		—	—	35		60
		4 times speed	I_{DD5} (3)		—	—	3		7
			I_{DD3} (3)		—	—	40		70
Input voltage 1		"H" level	V_{IH5}	CMOS input pins except for analog input pins (5 V)	3.5	—	—	V	
		"L" level	V_{IL5}		—	—	1.5		
Input current 1		"H" level	I_{IH5}	$V_{IH5} = 5\text{ V}$	—	—	1.0	μA	
		"L" level	I_{IL5}	$V_{IL5} = 0\text{ V}$	-1.0	—	—		
Tri-state leak current 1		"H" level	I_{TLH5}	$V_{IH5} = 5\text{ V}$	Pins grouped as 1, 2, 3 in the following table	—	—	1.0	μA
		"L" level	I_{TLL5}	$V_{IL5} = 0\text{ V}$		-1.0	—	—	
Output current 1		"H" level	I_{OH5} (1)	$V_{OH5} = 4.6\text{ V}$	Pins grouped as 1 in the following table	—	—	-2.0	mA
		"L" level	I_{OL5} (1)	$V_{OL5} = 0.4\text{ V}$		2.0	—	—	
		"H" level	I_{OH5} (2)	$V_{OH5} = 4.6\text{ V}$	Pins grouped as 2 and 3 in the following table	—	—	-4.0	
		"L" level	I_{OL5} (2)	$V_{OL5} = 0.4\text{ V}$		4.0	—	—	
Input voltage 2		"H" level	V_{IH3}	CMOS input pins except for analog input pins (3 V)	2.3	—	—	V	
		"L" level	V_{IL3}		—	—	1.0		
Input current 2		"H" level	I_{IH3}	$V_{IH3} = 3.3\text{ V}$	—	—	1.0	μA	
		"L" level	I_{IL3}	$V_{IL3} = 0\text{ V}$	-1.0	—	—		
Tri-state leak current 2		"H" level	I_{TLH3}	$V_{IH3} = 3.3\text{ V}$	Pins grouped as 4 and 5 in the following table	—	—	1.0	μA
		"L" level	I_{TLL3}	$V_{IL3} = 0\text{ V}$		-1.0	—	—	
Output current 2		"H" level	I_{OH3} (1)	$V_{OH3} = 2.9\text{ V}$	Pins grouped as 4 in the following table	—	—	-2.0	mA
		"L" level	I_{OL3} (1)	$V_{OL3} = 0.4\text{ V}$		2.0	—	—	
		"H" level	I_{OH3} (2)	$V_{OH3} = 2.9\text{ V}$	Pins grouped as 5 in the following table	—	-80	—	μA
		"L" level	I_{OL3} (2)	$V_{OL3} = 0.4\text{ V}$		—	80	—	
		"H" level	I_{OH3} (3)	$V_{OH3} = 2.9\text{ V}$	Pins grouped as 6 in the following table	—	-121	—	
		"L" level	I_{OL3} (3)	$V_{OL3} = 0.4\text{ V}$		—	121	—	
VREF output on resistance		R_{ON}	—	—	—	—	500	Ω	
Pull-up resistance		R_{UP}	—	Pins grouped as 8 in the following table	25	50	75	$\text{k}\Omega$	
Pin built-in output resistance		R_{O1}	—	Pins grouped as 5 in the following table	—	5.0	—	$\text{k}\Omega$	
		R_{O2}	—	Pins grouped as 6 and 7 in the following table	—	3.3	—		

DC Characteristics (2)

(unless otherwise specified, $V_{DD5} = V_{DD3} = AV_{DD3} = DV_{DD3} = XV_{DD3} = PV_{DD3} = 3.3\text{ V}$, $T_a = 25^\circ\text{C}$)

Characteristics		Symbol	Test Circuit	Test Condition	Min	Typ.	Max	Unit	
Operating power supply voltage		V_{DD5}	—	—	3.0	3.3	3.6	V	
		V_{DD3}	—	—					
		AV_{DD3}	—	—					
		DV_{DD3}	—	—					
		XV_{DD3}	—	—					
		PV_{DD3}	—	—					
Operating power supply current		Normal speed	$I_{DD3(1)}$	—	—	32	55	mA	
		Double speed	$I_{DD3(2)}$	—	$XI = 16.9344\text{ MHz}$	—	37.5		66
		4 times speed	$I_{DD3(3)}$	—	—	—	43		77
Input voltage		"H" level	V_{IH3}	—	CMOS input pins except for analog input pins (3 V)		2.3	—	V
		"L" level	V_{IL3}	—			—	—	
Input current		"H" level	I_{IH3}	—	$V_{IH3} = 3.3\text{ V}$	—	—	1.0	μA
		"L" level	I_{IL3}	—	$V_{IL3} = 0\text{ V}$	-1.0	—	—	
Tri-state leak current		"H" level	I_{TLH3}	—	$V_{IH3} = 3.3\text{ V}$	Pins grouped as 4 and 5 in the following table		—	μA
		"L" level	I_{TLL3}	—	$V_{IL3} = 0\text{ V}$			-1.0	
Output current		"H" level	$I_{OH3(1)}$	—	$V_{OH3} = 2.9\text{ V}$	Pins grouped as 1 in the following table		—	mA
		"L" level	$I_{OL3(1)}$	—	$V_{OL3} = 0.4\text{ V}$			1.0	
		"H" level	$I_{OH3(2)}$	—	$V_{OH3} = 2.9\text{ V}$	Pins grouped as 2 and 3 in the following table		—	—
		"L" level	$I_{OL3(2)}$	—	$V_{OL3} = 0.4\text{ V}$			2.0	
		"H" level	$I_{OH3(3)}$	—	$V_{OH3} = 2.9\text{ V}$	Pins grouped as 4 in the following table		—	—
		"L" level	$I_{OL3(3)}$	—	$V_{OL3} = 0.4\text{ V}$			2.0	
		"H" level	$I_{OH3(4)}$	—	$V_{OH3} = 2.9\text{ V}$	Pins grouped as 5 in the following table		—	-80
		"L" level	$I_{OL3(4)}$	—	$V_{OL3} = 0.4\text{ V}$			—	
		"H" level	$I_{OH3(5)}$	—	$V_{OH3} = 2.9\text{ V}$	Pins grouped as 6 in the following table		—	-121
		"L" level	$I_{OL3(5)}$	—	$V_{OL3} = 0.4\text{ V}$			—	
V _{REF} output on resistance		R_{ON}	—	—	—	—	500	Ω	
Pull-up resistance		R_{UP}	—	Pins grouped as 8 in the following table	50	80	120	k Ω	
Pin built-in output resistance		R_{O1}	—	Pins grouped as 5 in the following table	—	5.0	—	k Ω	
		R_{O2}	—	Pins grouped as 6 and 7 in the following table	—	3.3	—		

Pin Group	Pin Name
1	SBOK, SFSY, SBSY, IO0, IO1, ZDET
2	BCK, LRCK, AOUT, DOUT, IPF, CLCK, DATA
3	BUS3, BUS2, BUS1, BUS0
4	SEL, TMAX
5	PDO
6	RFGC, TEBC, FMO, DMO
7	FOO, TRO
8	/RST

AC Characteristics

(unless otherwise specified, $V_{DD5} = 5\text{ V}$, $V_{DD3} = AV_{DD3} = DV_{DD3} = XV_{DD3} = PV_{DD3} = 3.3\text{ V}$, $T_a = 25^\circ\text{C}$)

1. Microcontroller Interface Timing

Characteristics	Symbol	Test Circuit	Test Condition	Min	Typ.	Max	Unit
/CCE = "H" pulse width	tCC	—	—	120	—	—	ns
Data disable time	tSZ1	—	BUCK rise reference	0	—	—	
/CCE, BUCK delay time	tCB	—	/CCE fall reference	0	—	—	
BUCK, /CCE delay time	tBC	—	BUCK rise reference	0	—	—	
BUCK = "L" pulse width	tBLW	—	Write, SRC mode	120	—	—	
	tBLW	—	QDRC mode	240	—	—	
BUCK = "H" pulse width (1)	tBHW	—	Write, SRC mode	120	—	—	
BUCK = "H" pulse width (2)	tBHW	—	QDRC mode (normal speed)	3000	—	—	
BUCK = "H" pulse width (3)	tBHW	—	QDRC mode (double speed)	1500	—	—	
BUCK = "H" pulse width (4)	tBHW	—	QDRC mode ($\times 4$ speed)	800	—	—	
Write data setup time	tWS	—	BUCK rise reference	60	—	—	
Write data hold time	tWH	—	BUCK rise reference	20	—	—	
Data disable time	tSZ2	—	BUCK fall reference	0	—	—	
Read data access time	tRD	—	BUCK fall reference	0	—	—	

(1) Write command mode

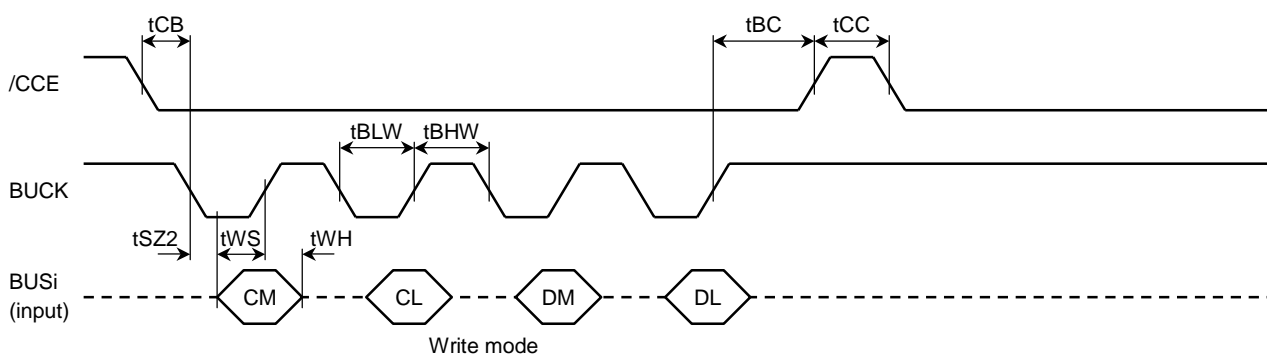

(2) Write command mode: Bxxxxx, Fxxxxx commands

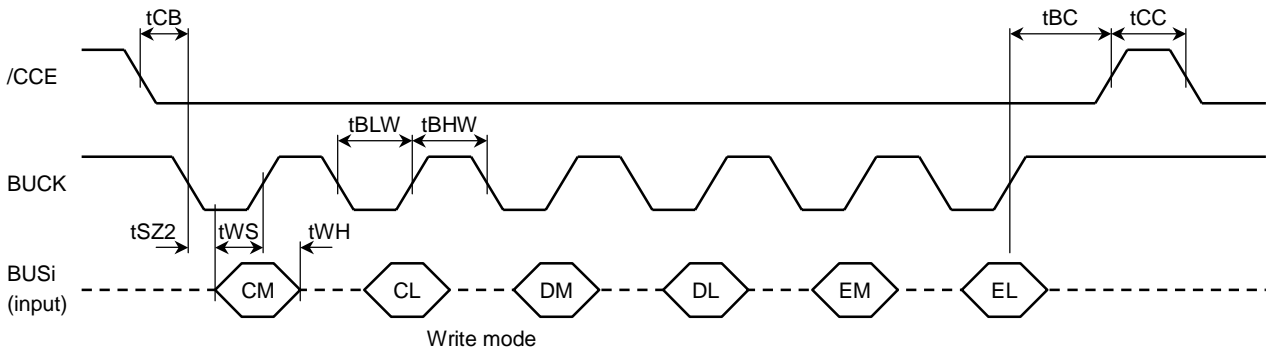

(3) Read command mode

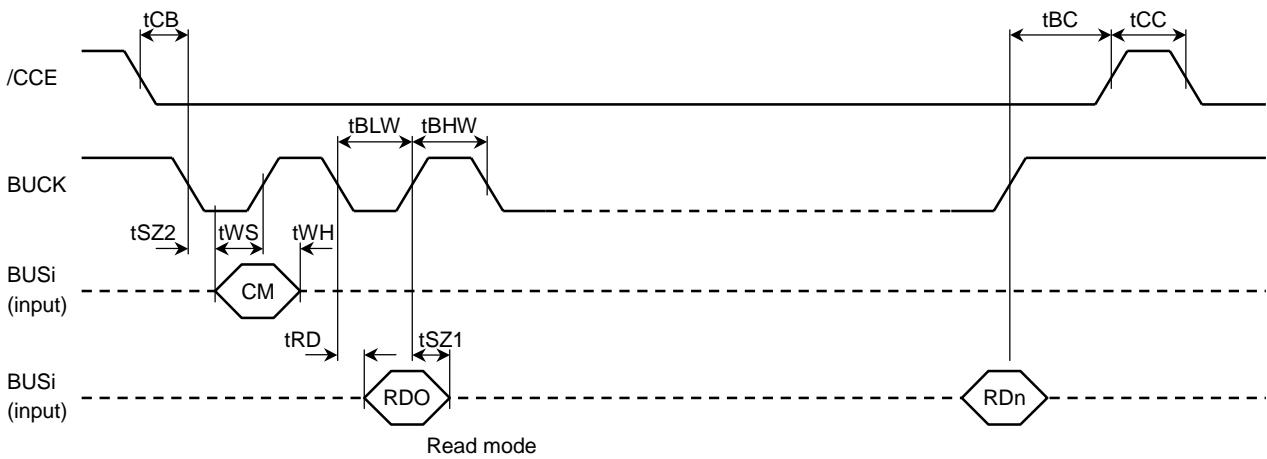

2. AOUT Data Output Timing

Characteristics		Symbol	Test Circuit	Test Condition	Min	Typ.	Max	Unit
Transfer time (1)	"H" level	tpLH1	—	LRCK	—	—	5	ns
	"L" level	tpHL1	—		—	—	5	
Transfer time (2)	"H" level	tpLH2	—	AOUT	—	—	5	
	"L" level	tpHL2	—		—	—	5	

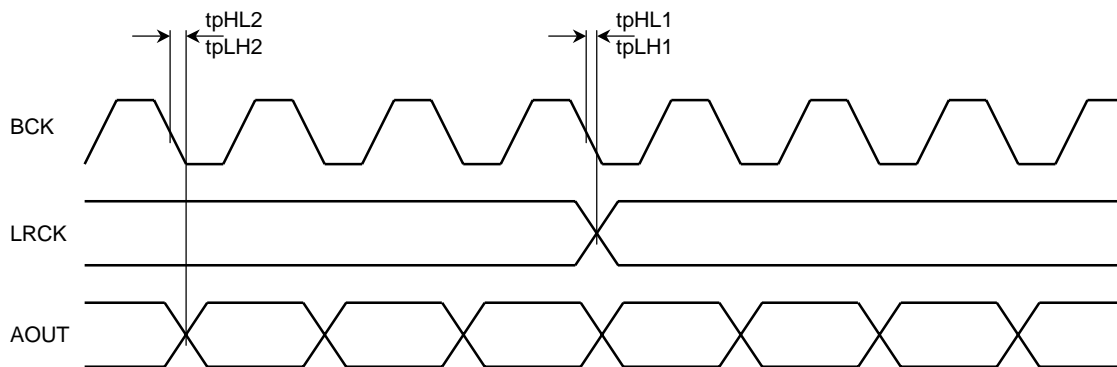

3. DATA, CLCK Input/Output Timing

(1) CLCK input mode (regardless of setting of HS and UHS bits of SPEED command)

Characteristics		Symbol	Test Circuit	Test Condition	Min	Typ.	Max	Unit
Clock pulse width	"H" level	tHW	—	CLCK input mode	50	—	—	ns
	"L" level	tLW	—		50	—	—	
Input setup time		tSU	—	CLCK input mode	—	—	—	
Transfer time (1)		tpHL1	—	CLCK input mode	—	—	5	
Transfer time (2)	"H" level	tpLH ₅₂	—	CLCK input mode	—	—	15	
	"L" level	tpHL ₅₂	—		—	—	15	
	"H" level	tpLH ₅₂	—	V _{DD5} = 3.3 V	—	—	20	
	"L" level	tpHL ₅₂	—		—	—	20	

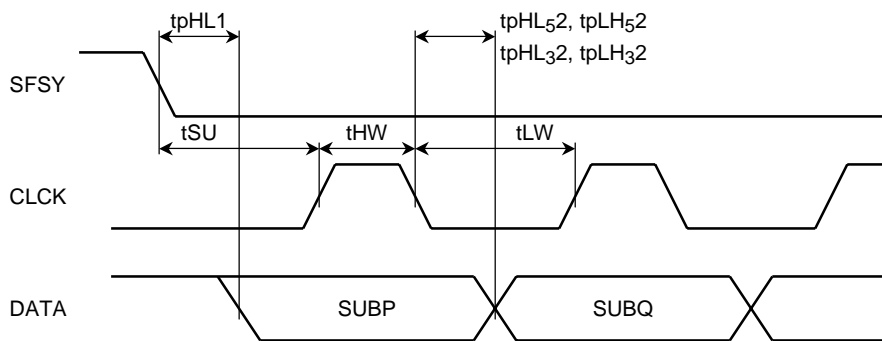

(2) CLCK output mode (tHW, tLW, tpLH3 only, × 1/n at ×n speed)

Characteristics		Symbol	Test Circuit	Test Condition	Min	Typ.	Max	Unit
Clock pulse width	"H" level	tHW	—	CLCK output mode	—	—	950	ns
	"L" level	tLW	—		—	—	950	
Transfer time (1)		tpHL1	—	CLCK output mode	—	—	5	
Transfer time (2)	"H" level	tpLH ₅₂	—	CLCK output mode	—	—	15	
	"L" level	tpHL ₅₂	—		—	—	15	
	"H" level	tpLH ₃₂	—	V _{DD5} = 3.3 V	—	—	20	
	"L" level	tpHL ₃₂	—		—	—	20	
Transfer time (3)		tpLH3	—	CLCK output mode	—	—	850	

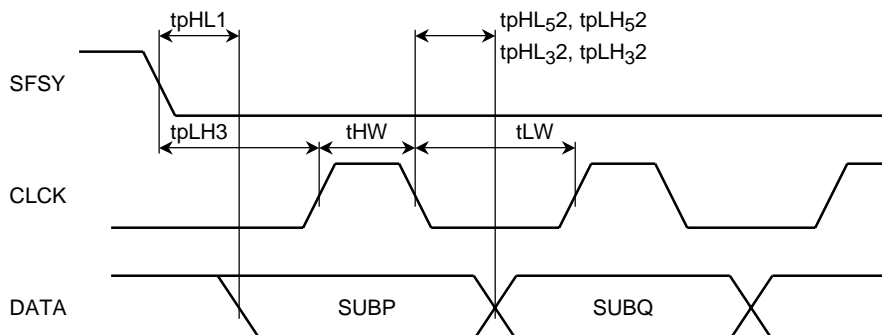

4. SBSY, SBOK Input/Output Timing

Characteristics	Symbol	Test Circuit	Test Condition	Min	Typ.	Max	Unit
Transfer time (1)	"H" level	tpLH1	SBSY	—	—	5	ns
	"L" level	tpHL1		—	—	10	
Transfer time (2)	"H" level	tpLH2	SBOK	—	—	15	
	"L" level	tpHL2		—	—	20	

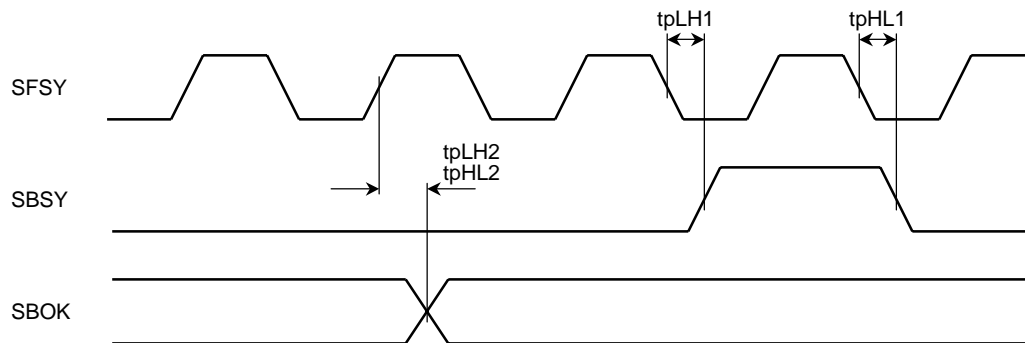

5. Output Pin Timing

Characteristics	Symbol	Test Circuit	Test Condition	Min	Typ.	Max	Unit
Output rise time 5 (1)	tor51	—	Pins grouped as 1 below $V_{DD5} = 3.3\text{ V}$	—	—	7	ns
Output fall time 5 (1)	tof51			—	—	12	
Output rise time 3 (1)	tor31			—	—	14	
Output fall time 3 (1)	tof31			—	—	24	
Output rise time 5 (2)	tor52	—	Pins grouped as 2 below $V_{DD5} = 3.3\text{ V}$	—	—	7	
Output fall time 5 (2)	tof52			—	—	7	
Output rise time 3 (2)	tor32			—	—	14	
Output fall time 3 (2)	tof32			—	—	14	
Output rise time 5 (3)	tor53	—	Pins grouped as 3 below $V_{DD5} = 3.3\text{ V}$	—	—	7	
Output fall time 5 (3)	tof53			—	—	7	
Output rise time 3 (3)	tor33			—	—	14	
Output fall time 3 (3)	tof33			—	—	14	
Output rise time 5 (4)	tor54	—	Pins grouped as 4 below	—	—	10	
Output fall time 5 (4)	tof54	—		—	—	10	

Pin Group	Pin Name
1	SBOK, SFSY, SBSY, IO0, IO1, ZDET
2	BCK, LRCK, AOUT, DOUT, IPF, CLCK, DATA
3	BUS3, BUS2, BUS1, BUS0
4	TMAX, SEL

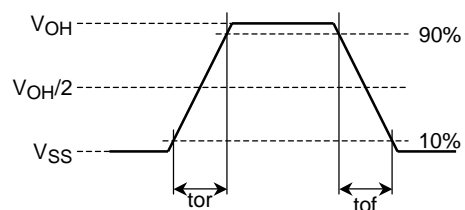

Analog Circuit Characteristics

1. AD Converter

Characteristics		Test Circuit	Test Condition	Min	Typ.	Max	Unit
Resolution		—	—	—	8	—	bit
Sampling frequency	FE	—	—	—	176.4	—	kHz
	TE	—		—	176.4	—	
	SBAD	—		—	88.2	—	
	RFRP	—		—	176.4	—	
Conversion input range		—	$AV_{SS} = 0\text{ V}$ $AV_{DD3} = 3.3\text{ V}$	$0.15 \times AV_{DD3}$	—	$0.85 \times AV_{DD3}$	V

2. DA Converter (focus and tracking equalizer output)

Characteristics		Test Circuit	Test Condition	Min	Typ.	Max	Unit
Number of bits		—	—	—	—	5	bit
Sampling frequency		—	—	—	—	2.8	MHz
Signal output range		—	$AV_{SS} = 0\text{ V}$, $AV_{DD3} = 3.3\text{ V}$	AV_{SS3}	—	AV_{DD3}	V

3. PLL Filter Amp

Characteristics		Test Circuit	Test Condition	Min	Typ.	Max	Unit
I/O signal range		—	—	AV_{SS3}	—	PV_{DD3}	V
Frequency characteristic		—	-3dB point (Gain = 1)	—	8	—	MHz

4. VCO (PLL)

Characteristics		Test Circuit	Test Condition	Min	Typ.	Max	Unit
Center oscillation frequency		—	$LPFO = V_{REF}$	—	34	—	MHz
Frequency variable range	—	—	[VCOGSL] bit = "L"	—	± 50	—	%
	—	—	[VCOGSL] bit = "H"	—	± 60	—	

5. TEZI Signal Comparator

Characteristics		Test Circuit	Test Condition	Min	Typ.	Max	Unit
Input range		—	—	AV_{SS3}	—	AV_{DD3}	V
Hysteresis voltage		—	V_{REF} reference	—	± 50	—	mV

6. RFZI Signal Comparator

Characteristics		Test Circuit	Test Condition	Min	Typ.	Max	Unit
Input range		—	—	AV_{SS3}	—	AV_{DD3}	V
Hysteresis voltage		—	V_{REF} reference	—	± 50	—	mV

7. Data Slicer Circuit

(1) Comparator

Characteristics	Test Circuit	Test Condition	Min	Typ.	Max	Unit
Input amplitude	—	V _{REF} reference	0.6	1.2	2.0	V _{pp}

(2) R-2R DAC (digital slicer DAC)

Characteristics	Test Circuit	Test Condition	Min	Typ.	Max	Unit
Output conversion range	—	—	AV _{SS3}	—	AV _{DD3}	V
Output impedance	—	—	—	2.5	—	kΩ

8. Audio DAC Characteristics

Characteristics	Symbol	Test Circuit	Test Condition	Min	Typ.	Max	Unit
Total harmonic distortion + noise	THD + N (1)	1	1 kHz sine wave, full-scale input	—	-88	-80	dB
	THD + N (2)		10 kHz sine wave, full-scale input	—	-80	-75	
S/N ratio	S/N (1)	1	Internal Zero detect = OFF	87	92	—	dB
	S/N (2)		Internal Zero detect = ON	95	100	—	
Dynamic range	DR	1	1 kHz sine wave, -60dB input conversion	85	90	—	dB
Cross talk	CT	1	1 kHz sine wave, full-scale input	—	-90	-85	dB
Analog output amplitude	DAC out	1	1 kHz sine wave, full-scale input	790	820	850	mVrms

Test Circuit 1: Application circuit is used.

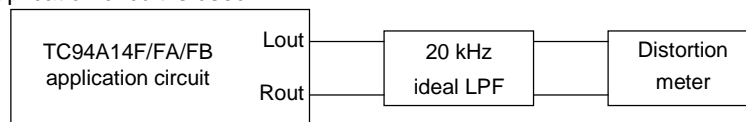

LPF: Filter with built-in Shibasoku 725D
Distortion meter: Shibasoku 725D equivalent

Characteristic	Distortion Filter Setting A-weight
THD + N, CT	OFF
S/N, DR	ON

A-weight: IEC-A equivalent

Application Circuit

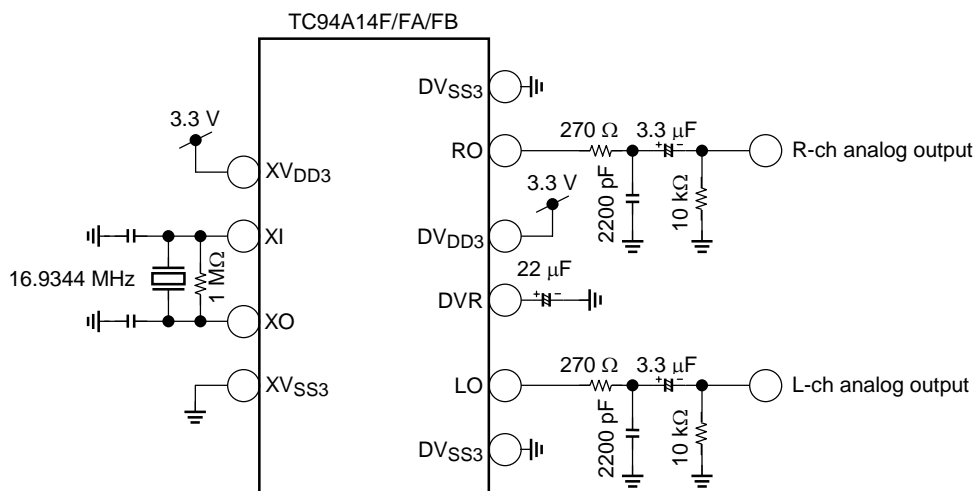

Package Dimensions

QFP64-P-1414-0.80A

Unit : mm

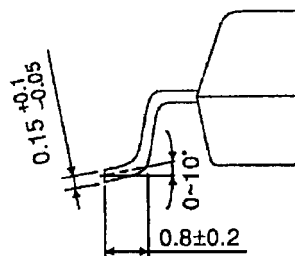
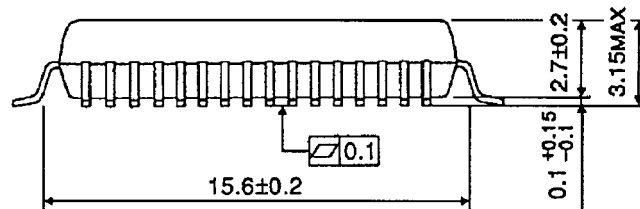
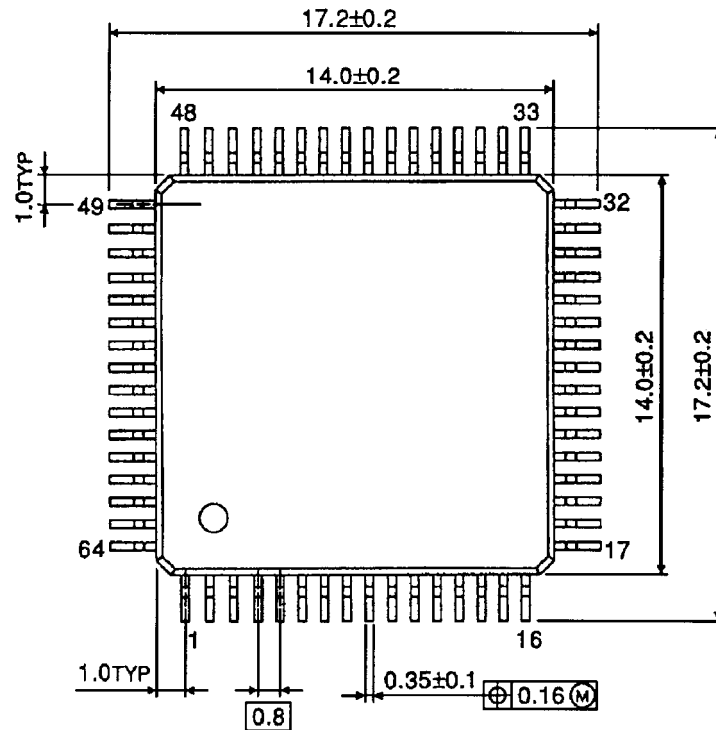

Weight: 0.5 g (typ.)

Package Dimensions

LQFP64-P-1010-0.50

Unit : mm

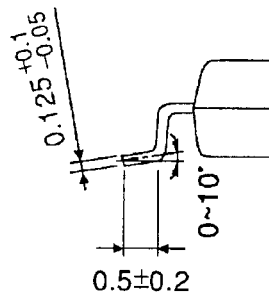
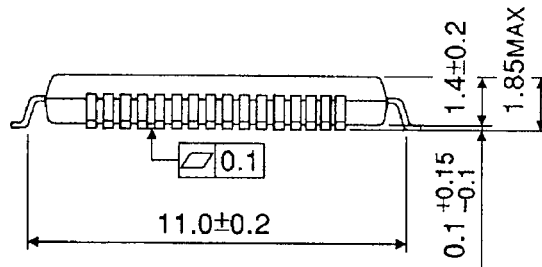
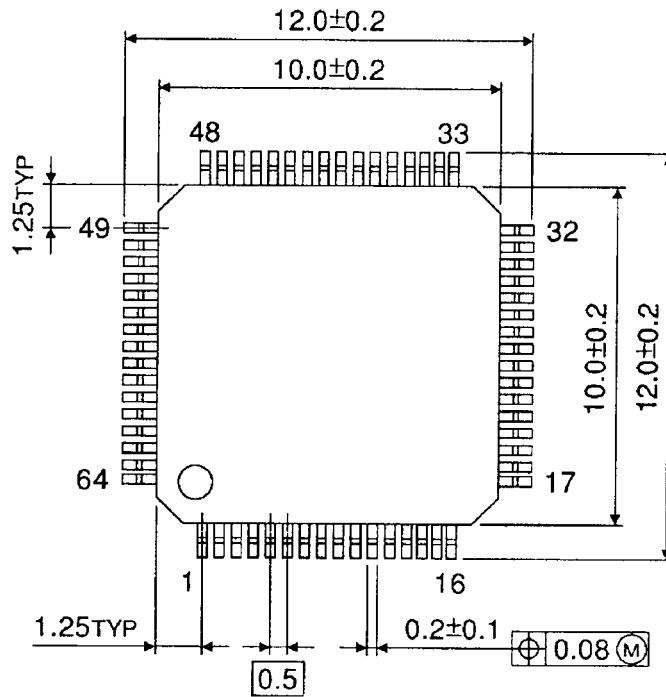

Weight: 0.4 g (typ.)

Package Dimensions

QFP64-P-1212-0.65

Unit : mm

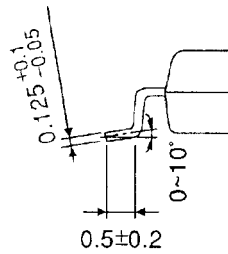
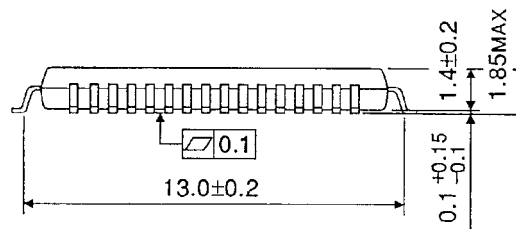
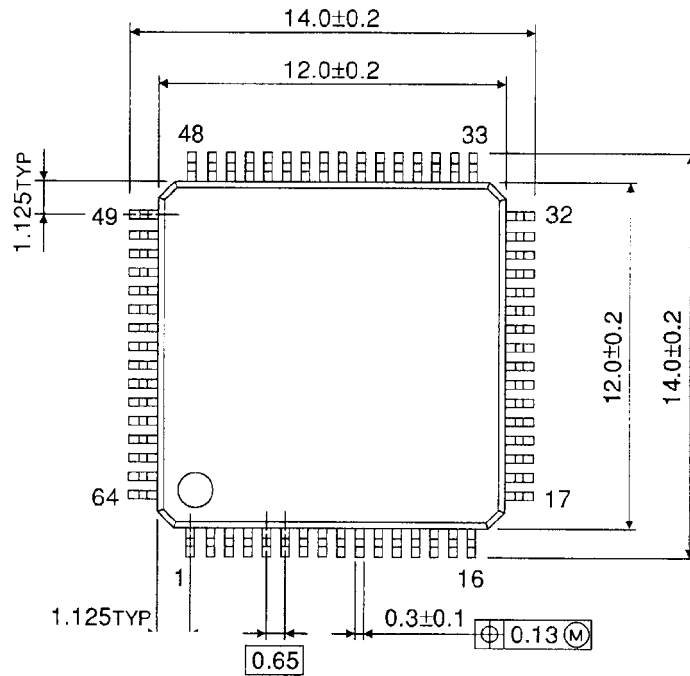

Weight: 0.45 g (typ.)

RESTRICTIONS ON PRODUCT USE

000707EBA

- TOSHIBA is continually working to improve the quality and reliability of its products. Nevertheless, semiconductor devices in general can malfunction or fail due to their inherent electrical sensitivity and vulnerability to physical stress. It is the responsibility of the buyer, when utilizing TOSHIBA products, to comply with the standards of safety in making a safe design for the entire system, and to avoid situations in which a malfunction or failure of such TOSHIBA products could cause loss of human life, bodily injury or damage to property.
In developing your designs, please ensure that TOSHIBA products are used within specified operating ranges as set forth in the most recent TOSHIBA products specifications. Also, please keep in mind the precautions and conditions set forth in the "Handling Guide for Semiconductor Devices," or "TOSHIBA Semiconductor Reliability Handbook" etc..
- The TOSHIBA products listed in this document are intended for usage in general electronics applications (computer, personal equipment, office equipment, measuring equipment, industrial robotics, domestic appliances, etc.). These TOSHIBA products are neither intended nor warranted for usage in equipment that requires extraordinarily high quality and/or reliability or a malfunction or failure of which may cause loss of human life or bodily injury ("Unintended Usage"). Unintended Usage include atomic energy control instruments, airplane or spaceship instruments, transportation instruments, traffic signal instruments, combustion control instruments, medical instruments, all types of safety devices, etc.. Unintended Usage of TOSHIBA products listed in this document shall be made at the customer's own risk.
- The products described in this document are subject to the foreign exchange and foreign trade laws.
- The information contained herein is presented only as a guide for the applications of our products. No responsibility is assumed by TOSHIBA CORPORATION for any infringements of intellectual property or other rights of the third parties which may result from its use. No license is granted by implication or otherwise under any intellectual property or other rights of TOSHIBA CORPORATION or others.
- The information contained herein is subject to change without notice.