



**M54HC298**  
**M74HC298**

**QUAD 2 CHANNEL MULTIPLEXER/REGISTER**

- **HIGH SPEED**  
f<sub>MAX</sub> = 73 MHz (typ.) AT V<sub>CC</sub> = 5 V
- **LOW POWER DISSIPATION**  
I<sub>CC</sub> = 4 μA (MAX.) AT T<sub>A</sub> = 25 °C
- **HIGH NOISE IMMUNITY**  
V<sub>NIH</sub> = V<sub>NIL</sub> = 28 % V<sub>CC</sub> (MIN.)
- **OUTPUT DRIVE CAPABILITY**  
10 LSTTL LOADS
- **SYMMETRICAL OUTPUT IMPEDANCE**  
|I<sub>OH</sub>| = I<sub>OL</sub> = 4 mA (MIN.)
- **BALANCED PROPAGATION DELAYS**  
t<sub>PLH</sub> = t<sub>PHL</sub>
- **WIDE OPERATING VOLTAGE RANGE**  
V<sub>CC</sub> (OPR) = 2 V TO 6 V
- **PIN AND FUNCTION COMPATIBLE**  
WITH 54/74LS298

**DESCRIPTION**

The M54/74HC298 is a high speed CMOS QUAD 2-CHANNEL MULTIPLEXER/REGISTER fabricated in silicon gate C<sup>2</sup>MOS technology.

It has the same high speed performance of LSTTL combined with true CMOS low power consumption. These circuits are controlled by the signals WORD SELECT and CLOCK. When the WORD SELECT input is taken low Word 1 (A1, B1, C1 and D1) is presented to the input of the flip-flops, and when WORD SELECT is high Word 2 (A2, B2, C2 and D2) is presented to the inputs of the flip-flops. The select word is clocked to the output terminals on the negative edge of the clock pulse. All inputs are equipped with protection circuits against static discharge and transient excess voltage.

**INPUT AND OUTPUT EQUIVALENT CIRCUIT**

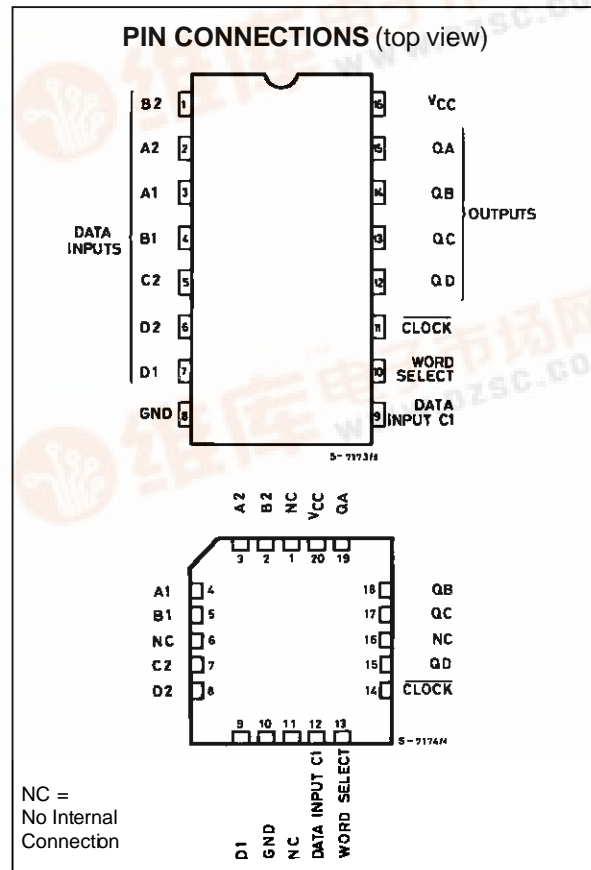
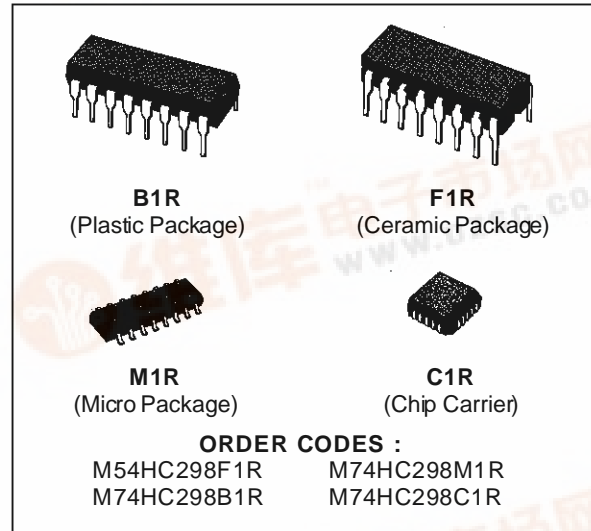
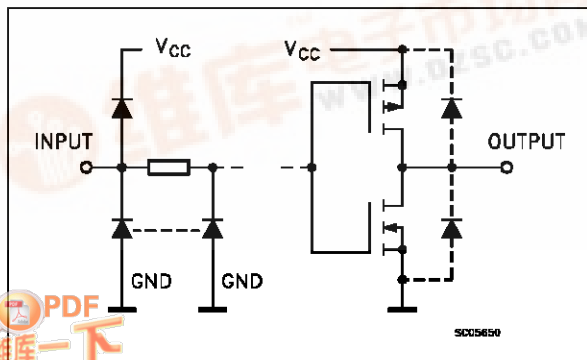

# M54/M74HC298

## TRUTH TABLE

INPUTS		OUTPUTS			
WORD SELECT	CLOCK	QA	QB	QC	QD
L		a1	b1	c1	d1
H		a2	b2	c2	d2
X		QA0	QB0	QC0	QD0

X : DON'T CARE (INCLUDING TRANSITION)

a1, a2, ETC : THE LEVEL OF STEAY STATE INPUT AT a1, a2, etc.

QA0, QB0, ETC : THE LEVEL OF QA, QB, ETC ENTERED ON THE MOST RECENT NEGATIVE TRANSITION OF THE CLOCK INPUT.

## LOGIC DIAGRAM

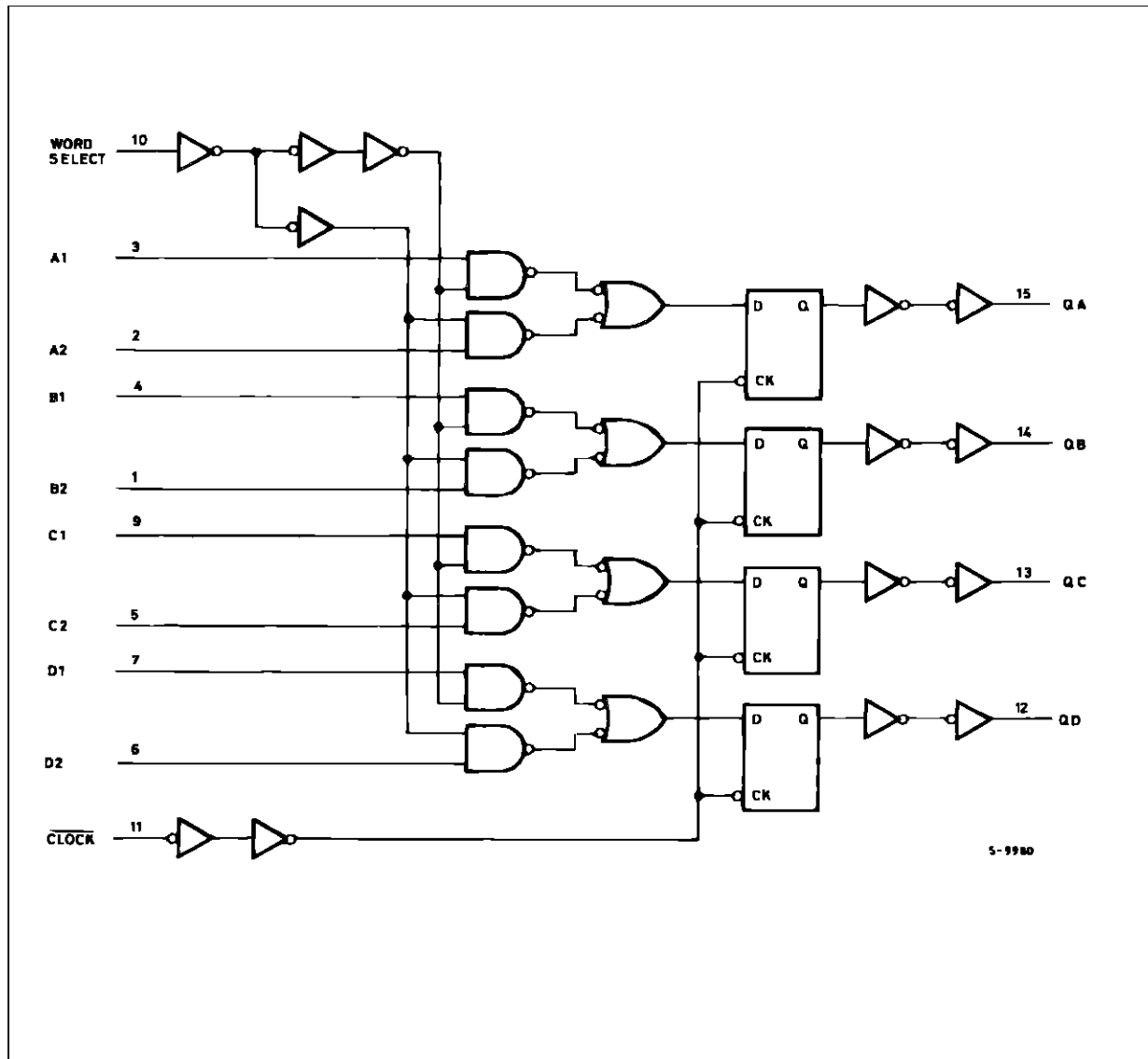

5-9980

**PIN DESCRIPTION**

PIN No	SYMBOL	NAME AND FUNCTION
1, 2, 5, 6	A2, B2, C2, D2	Word 2 Data Inputs
3, 4, 7, 9	A1, B1, C1, D1	Word 1 Data Inputs
12 to 15	QA to QD	Outputs
10	WORD SELECT	Word Select Input
11	CLOCK	Clock Input (HIGH to LOW, Edge-triggered)
8	GND	Ground (0V)
16	V <sub>CC</sub>	Positive Supply Voltage

**IEC LOGIC SYMBOL**

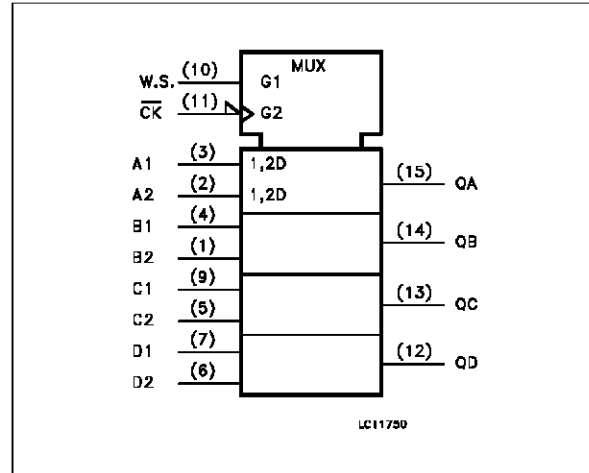

**ABSOLUTE MAXIMUM RATINGS**

Symbol	Parameter	Value	Unit
V <sub>CC</sub>	Supply Voltage	-0.5 to +7	V
V <sub>I</sub>	DC Input Voltage	-0.5 to V <sub>CC</sub> + 0.5	V
V <sub>O</sub>	DC Output Voltage	-0.5 to V <sub>CC</sub> + 0.5	V
I <sub>IK</sub>	DC Input Diode Current	± 20	mA
I <sub>OK</sub>	DC Output Diode Current	± 20	mA
I <sub>O</sub>	DC Output Source Sink Current Per Output Pin	± 25	mA
I <sub>CC</sub> or I <sub>GND</sub>	DC V <sub>CC</sub> or Ground Current	± 50	mA
P <sub>D</sub>	Power Dissipation	500 (*)	mW
T <sub>stg</sub>	Storage Temperature	-65 to +150	°C
T <sub>L</sub>	Lead Temperature (10 sec)	300	°C

Absolute Maximum Ratings are those values beyond which damage to the device may occur. Functional operation under these condition is not implied.

(\*) 500 mW: ≡ 65 °C derate to 300 mW by 10mW/°C: 65 °C to 85 °C

**RECOMMENDED OPERATING CONDITIONS**

Symbol	Parameter	Value	Unit	
V <sub>CC</sub>	Supply Voltage	2 to 6	V	
V <sub>I</sub>	Input Voltage	0 to V <sub>CC</sub>	V	
V <sub>O</sub>	Output Voltage	0 to V <sub>CC</sub>	V	
T <sub>op</sub>	Operating Temperature: <b>M54HC Series</b> <b>M74HC Series</b>	-55 to +125 -40 to +85	°C °C	
t <sub>r</sub> , t <sub>f</sub>	Input Rise and Fall Time	V <sub>CC</sub> = 2 V V <sub>CC</sub> = 4.5 V V <sub>CC</sub> = 6 V	0 to 1000 0 to 500 0 to 400	ns

## M54/M74HC298

### DC SPECIFICATIONS

Symbol	Parameter	Test Conditions		Value						Unit		
		V <sub>CC</sub> (V)		T <sub>A</sub> = 25 °C 54HC and 74HC			-40 to 85 °C 74HC		-55 to 125 °C 54HC			
				Min.	Typ.	Max.	Min.	Max.	Min.		Max.	
V <sub>IH</sub>	High Level Input Voltage	2.0		1.5			1.5		1.5		V	
		4.5		3.15			3.15		3.15			
		6.0		4.2			4.2		4.2			
V <sub>IL</sub>	Low Level Input Voltage	2.0				0.5		0.5		0.5	V	
		4.5				1.35		1.35		1.35		
		6.0				1.8		1.8		1.8		
V <sub>OH</sub>	High Level Output Voltage	2.0	V <sub>I</sub> = V <sub>IH</sub> or V <sub>IL</sub>	I <sub>O</sub> = -20 μA	1.9	2.0		1.9		1.9	V	
		4.5			4.4	4.5		4.4		4.4		
		6.0			5.9	6.0		5.9		5.9		
		4.5	I <sub>O</sub> = -4.0 mA	4.18	4.31		4.13		4.10			
		6.0	I <sub>O</sub> = -5.2 mA	5.68	5.8		5.63		5.60			
V <sub>OL</sub>	Low Level Output Voltage	2.0	V <sub>I</sub> = V <sub>IH</sub> or V <sub>IL</sub>	I <sub>O</sub> = 20 μA		0.0	0.1		0.1		0.1	V
		4.5				0.0	0.1		0.1		0.1	
		6.0				0.0	0.1		0.1		0.1	
		4.5		I <sub>O</sub> = 4.0 mA		0.17	0.26		0.33		0.40	
		6.0		I <sub>O</sub> = 5.2 mA		0.18	0.26		0.33		0.40	
I <sub>I</sub>	Input Leakage Current	6.0	V <sub>I</sub> = V <sub>CC</sub> or GND			±0.1		±1		±1	μA	
I <sub>CC</sub>	Quiescent Supply Current	6.0	V <sub>I</sub> = V <sub>CC</sub> or GND			4		40		80	μA	

AC ELECTRICAL CHARACTERISTICS ( $C_L = 50$  pF, Input  $t_r = t_f = 6$  ns)

Symbol	Parameter	Test Conditions		Value						Unit	
		$V_{CC}$ (V)		$T_A = 25\text{ }^\circ\text{C}$ 54HC and 74HC			$-40$ to $85\text{ }^\circ\text{C}$ 74HC		$-55$ to $125\text{ }^\circ\text{C}$ 54HC		
				Min.	Typ.	Max.	Min.	Max.	Min.		Max.
$t_{TLH}$ $t_{THL}$	Output Transition Time	2.0			30	75		95		110	ns
		4.5			8	15		19		22	
		6.0			7	13		16		19	
$t_{PLH}$ $t_{PHL}$	Propagation Delay Time (CLOCK - Q)	2.0			45	125		155		190	ns
		4.5			15	25		31		38	
		6.0			13	21		26		32	
$f_{MAX}$	Maximum Clock Frequency	2.0		7	22		5.6		4.6		MHz
		4.5		35	67		28		23		
		6.0		41	79		33		25		
$t_{W(H)}$ $t_{W(L)}$	Minimum Pulse Width (CLOCK)	2.0			18	75		95		110	ns
		4.5			6	15		19		22	
		6.0			6	13		16		19	
$t_s$	Minimum Set-up Time (A, B, C, D)	2.0			12	50		65		75	ns
		4.5			3	10		13		15	
		6.0			2	9		11		13	
$t_s$	Minimum Set-up Time (W. S.)	2.0			30	75		95		110	ns
		4.5			8	15		19		22	
		6.0			6	13		16		19	
$t_h$	Minimum Hold Time (A, B, C, D)	2.0				25		30		40	ns
		4.5				5		6		8	
		6.0				4		5		7	
$t_h$	Minimum Hold Time (W. S.)	2.0				0		0		0	ns
		4.5				0		0		0	
		6.0				0		0		0	
$C_{IN}$	Input Capacitance				5	10		10		10	pF
$C_{PD}$ (*)	Power Dissipation Capacitance				39						pF

(\*)  $C_{PD}$  is defined as the value of the IC's internal equivalent capacitance which is calculated from the operating current consumption without load. (Refer to Test Circuit). Average operating current can be obtained by the following equation.  $I_{CC(opr)} = C_{PD} \bullet V_{CC} \bullet f_{IN} + I_{CC}/4$  (per bit), and the CPD for operating current can be obtained by the following equation:  $CPD = 27 + 12 \times n$

**M54/M74HC298**

**SWITCHING CHARACTERISTICS TEST WAVEFORM**

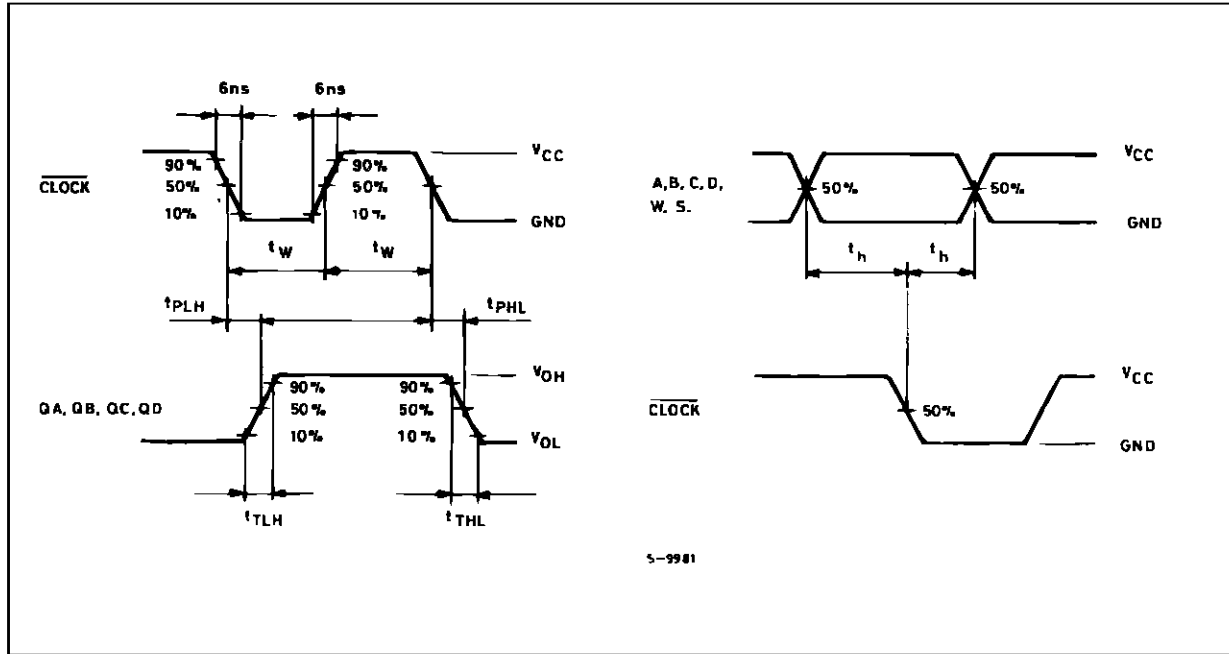

**TEST CIRCUIT**

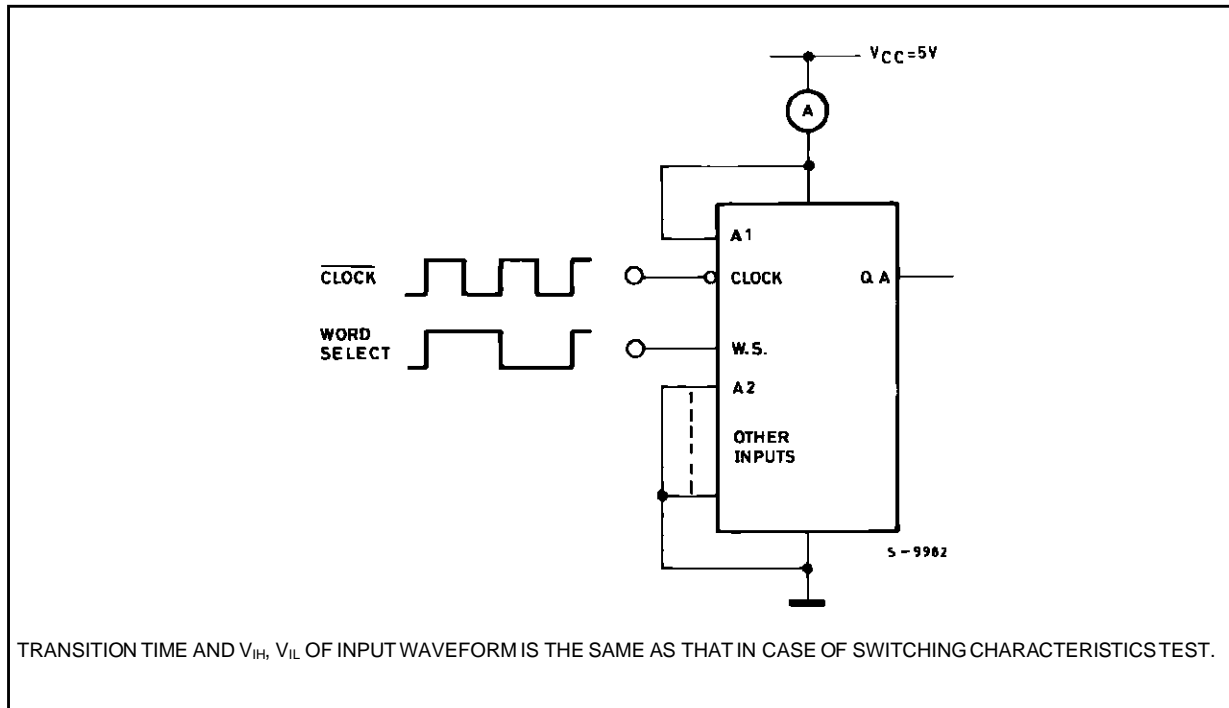

**Plastic DIP16 (0.25) MECHANICAL DATA**

DIM.	mm			inch		
	MIN.	TYP.	MAX.	MIN.	TYP.	MAX.
a1	0.51			0.020		
B	0.77		1.65	0.030		0.065
b		0.5			0.020	
b1		0.25			0.010	
D			20			0.787
E		8.5			0.335	
e		2.54			0.100	
e3		17.78			0.700	
F			7.1			0.280
I			5.1			0.201
L		3.3			0.130	
Z			1.27			0.050

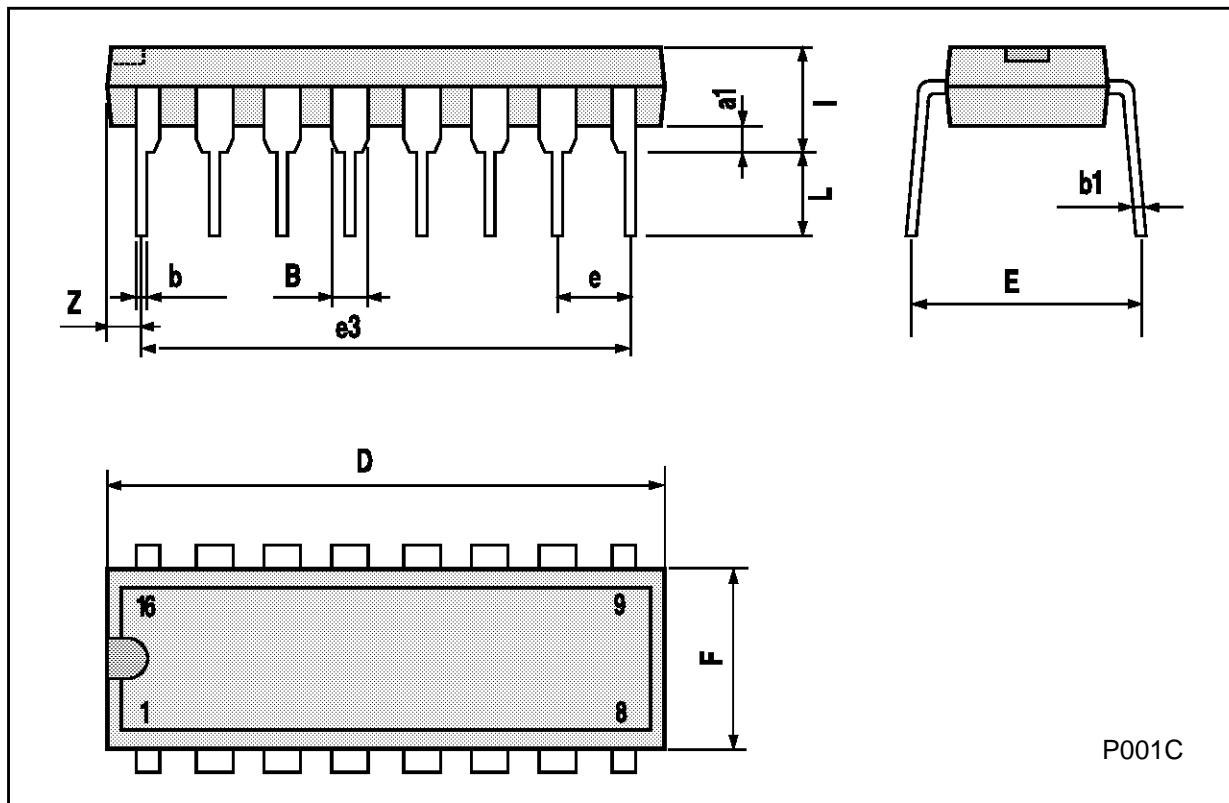

P001C

M54/M74HC298

**Ceramic DIP16/1 MECHANICAL DATA**

DIM.	mm			inch		
	MIN.	TYP.	MAX.	MIN.	TYP.	MAX.
A			20			0.787
B			7			0.276
D		3.3			0.130	
E	0.38			0.015		
e3		17.78			0.700	
F	2.29		2.79	0.090		0.110
G	0.4		0.55	0.016		0.022
H	1.17		1.52	0.046		0.060
L	0.22		0.31	0.009		0.012
M	0.51		1.27	0.020		0.050
N			10.3			0.406
P	7.8		8.05	0.307		0.317
Q			5.08			0.200

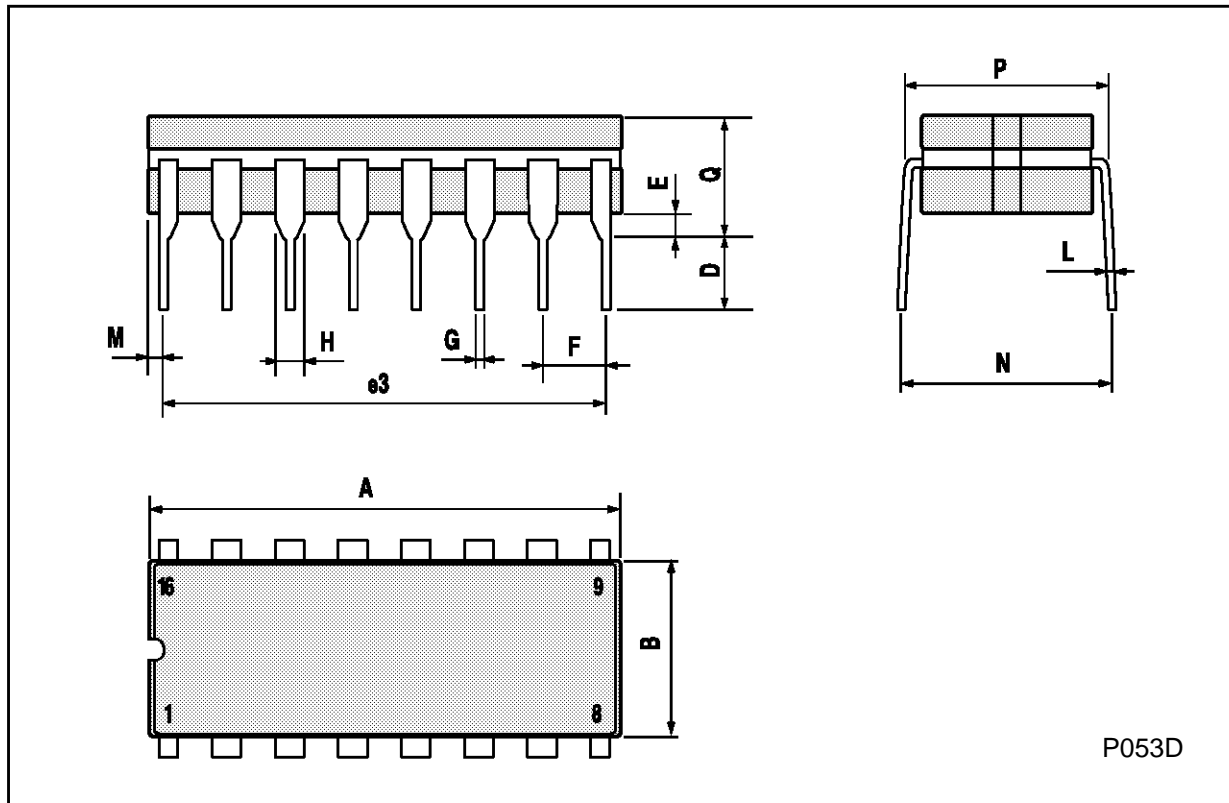

P053D



## SO16 (Narrow) MECHANICAL DATA

DIM.	mm			inch		
	MIN.	TYP.	MAX.	MIN.	TYP.	MAX.
A			1.75			0.068
a1	0.1		0.2	0.004		0.007
a2			1.65			0.064
b	0.35		0.46	0.013		0.018
b1	0.19		0.25	0.007		0.010
C		0.5			0.019	
c1	45° (typ.)					
D	9.8		10	0.385		0.393
E	5.8		6.2	0.228		0.244
e		1.27			0.050	
e3		8.89			0.350	
F	3.8		4.0	0.149		0.157
G	4.6		5.3	0.181		0.208
L	0.5		1.27	0.019		0.050
M			0.62			0.024
S	8° (max.)					

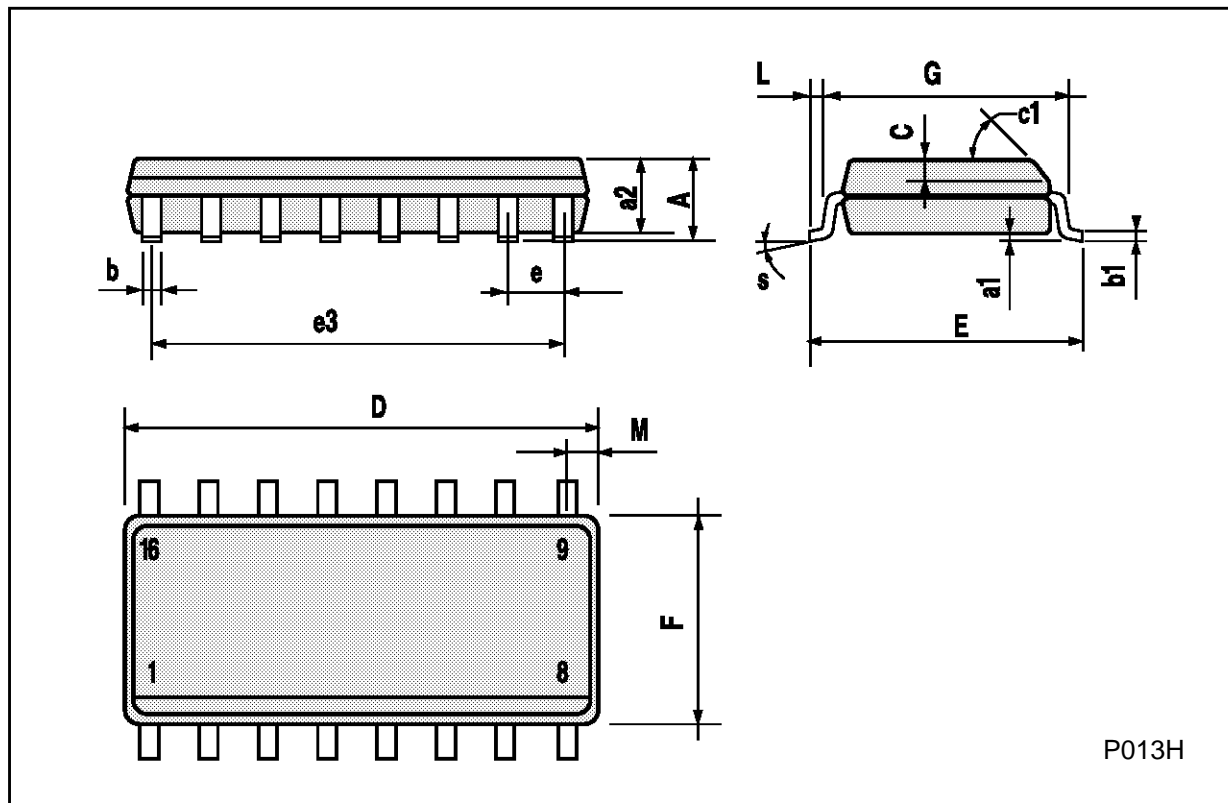

**PLCC20 MECHANICAL DATA**

DIM.	mm			inch		
	MIN.	TYP.	MAX.	MIN.	TYP.	MAX.
A	9.78		10.03	0.385		0.395
B	8.89		9.04	0.350		0.356
D	4.2		4.57	0.165		0.180
d1		2.54			0.100	
d2		0.56			0.022	
E	7.37		8.38	0.290		0.330
e		1.27			0.050	
e3		5.08			0.200	
F		0.38			0.015	
G			0.101			0.004
M		1.27			0.050	
M1		1.14			0.045	

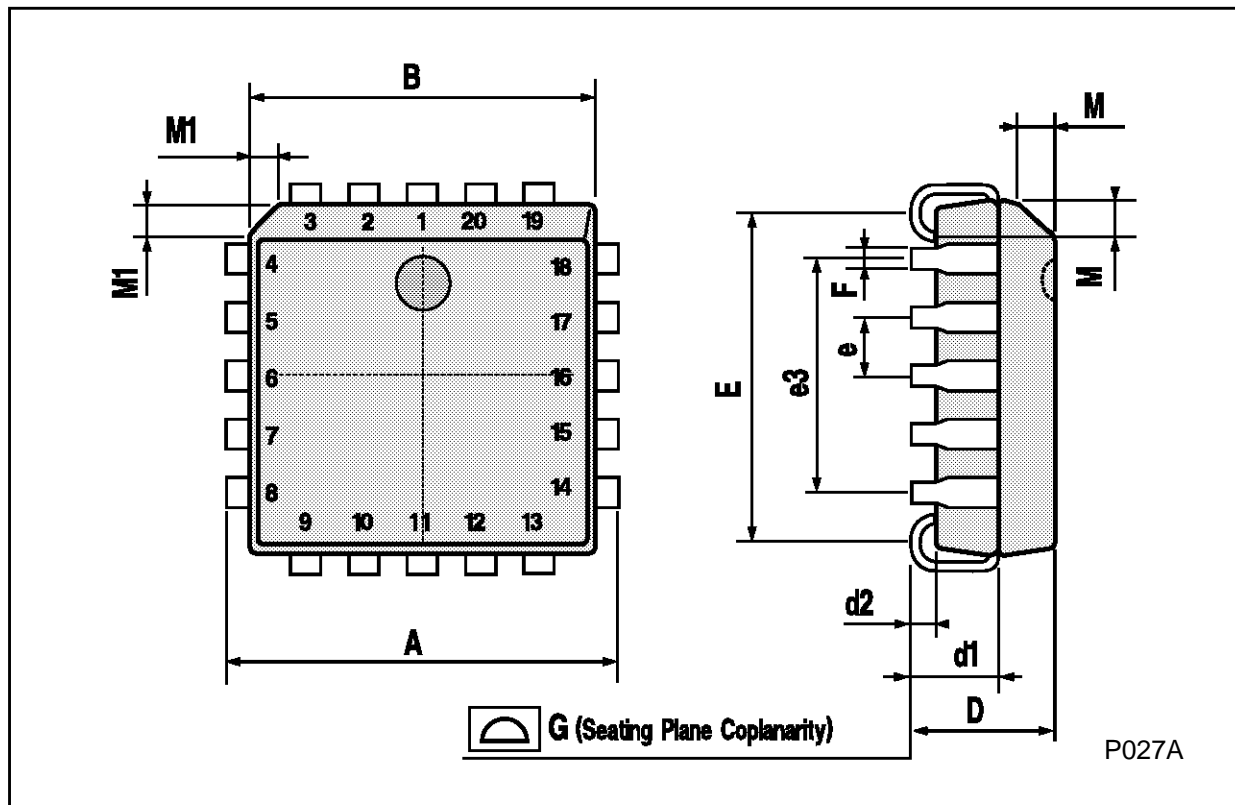

Information furnished is believed to be accurate and reliable. However, SGS-THOMSON Microelectronics assumes no responsibility for the consequences of use of such information nor for any infringement of patents or other rights of third parties which may result from its use. No license is granted by implication or otherwise under any patent or patent rights of SGS-THOMSON Microelectronics. Specifications mentioned in this publication are subject to change without notice. This publication supersedes and replaces all information previously supplied. SGS-THOMSON Microelectronics products are not authorized for use as critical components in life support devices or systems without express written approval of SGS-THOMSON Microelectronics.

© 1994 SGS-THOMSON Microelectronics - All Rights Reserved

SGS-THOMSON Microelectronics GROUP OF COMPANIES  
Australia - Brazil - France - Germany - Hong Kong - Italy - Japan - Korea - Malaysia - Malta - Morocco - The Netherlands -  
Singapore - Spain - Sweden - Switzerland - Taiwan - Thailand - United Kingdom - U.S.A