

MICROCHIP

Obsolete Device

28C17A

16K (2K x 8) CMOS EEPROM

FEATURES

- Fast Read Access Time—150 ns
- CMOS Technology for Low Power Dissipation
 - 30 mA Active
 - 100 μ A Standby
- Fast Byte Write Time—200 μ s or 1 ms
- Data Retention >200 years
- High Endurance - Minimum 10^4 Erase/Write Cycles
- Automatic Write Operation
 - Internal Control Timer
 - Auto-Clear Before Write Operation
 - On-Chip Address and Data Latches
- Data Polling; Ready/Busy
- Chip Clear Operation
- Enhanced Data Protection
 - VCC Detector
 - Pulse Filter
 - Write Inhibit
- Electronic Signature for Device Identification
- 5-Volt-Only Operation
- Organized 2Kx8 JEDEC Standard Pinout
 - 28 Pin Dual-In-Line Package
 - 32-Pin PLCC Package
- Available for Extended Temperature Ranges:
 - Commercial: 0°C to +70°C
 - Industrial: -40°C to +85°C

DESCRIPTION

The Microchip Technology Inc. 28C17A is a CMOS 16K non-volatile electrically Erasable PROM. The 28C17A is accessed like a static RAM for the read or write cycles without the need of external components. During a "byte write", the address and data are latched internally, freeing the microprocessor address and data bus for other operations. Following the initiation of write cycle, the device will go to a busy state and automatically clear and write the latched data using an internal control timer. To determine when the write cycle is complete, the user has a choice of monitoring the Ready/Busy output or using Data polling. The Ready/Busy pin is an open drain output, which allows easy configuration in wired-or systems. Alternatively, Data polling allows the user to read the location last written to when the write operation is complete. CMOS design and processing enables this part to be used in systems where reduced power consumption and reliability are required. A complete family of packages is offered to provide the utmost flexibility in applications.

PACKAGE TYPES

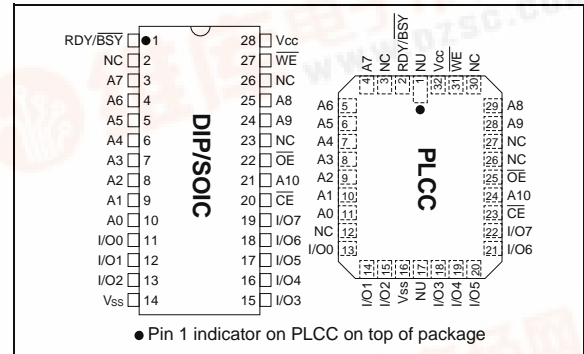

BLOCK DIAGRAM

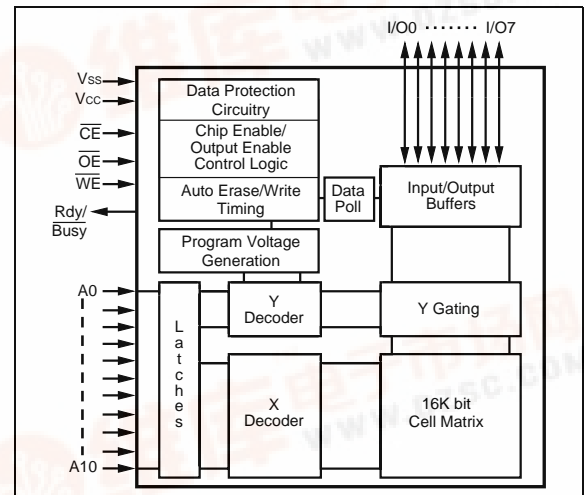

28C17A

1.0 ELECTRICAL CHARACTERISTICS

1.1 MAXIMUM RATINGS*

V_{CC} and input voltages w.r.t. V_{SS} -0.6V to + 6.25V
 Voltage on \overline{OE} w.r.t. V_{SS}.....-0.6V to +13.5V
 Voltage on A9 w.r.t. V_{SS}-0.6V to +13.5V
 Output Voltage w.r.t. V_{SS}.....-0.6V to V_{CC}+0.6V
 Storage temperature-65°C to +125°C
 Ambient temp. with power applied-50°C to +95°C

***Notice:** Stresses above those listed under “Maximum Ratings” may cause permanent damage to the device. This is a stress rating only and functional operation of the device at those or any other conditions above those indicated in the operation listings of this specification is not implied. Exposure to maximum rating conditions for extended periods may affect device reliability.

TABLE 1-1: PIN FUNCTION TABLE

Name	Function
A0 - A10	Address Inputs
\overline{CE}	Chip Enable
\overline{OE}	Output Enable
\overline{WE}	Write Enable
I/O0 - I/O7	Data Inputs/Outputs
RDY/ \overline{Busy}	Ready/ \overline{Busy}
V _{CC}	+5V Power Supply
V _{SS}	Ground
NC	No Connect; No Internal Connection
NU	Not Used; No External Connection is Allowed

TABLE 1-2: READ/WRITE OPERATION DC CHARACTERISTICS

V _{CC} = +5V ±10% Commercial (C): Tamb = 0°C to +70°C Industrial (I): Tamb = -40°C to +85°C						
Parameter	Status	Symbol	Min	Max	Units	Conditions
Input Voltages	Logic '1'	V _{IH}	2.0	V _{CC} +1	V	
	Logic '0'	V _{IL}	-0.1	0.8	V	
Input Leakage	—	I _{LI}	-10	10	μA	V _{IN} = -0.1V to V _{CC} +1
Input Capacitance	—	C _{IN}	—	10	pF	V _{IN} = 0V; Tamb = 25°C; f = 1 MHz
Output Voltages	Logic '1'	V _{OH}	2.4		V	I _{OH} = -400 μA I _{OL} = 2.1 mA
	Logic '0'	V _{OL}		0.45	V	
Output Leakage	—	I _{LO}	-10	10	μA	V _{OUT} = -0.1V to V _{CC} +0.1V
Output Capacitance	—	C _{OUT}	—	12	pF	V _{IN} = 0V; Tamb = 25°C; f = 1 MHz
Power Supply Current, Active	TTL input	I _{CC}	—	30	mA	f = 5 MHz (Note 1) V _{CC} = 5.5V;
Power Supply Current, Standby	TTL input	I _{CC(S)TTL}	—	2	mA	\overline{CE} = V _{IH} (0°C to +70°C) \overline{CE} = V _{IH} (-40°C to +85°C) \overline{CE} = V _{CC} -0.3 to V _{CC} +1 \overline{OE} = V _{CC} All other inputs equal V _{CC} or V _{SS}
	TTL input	I _{CC(S)TTL}		3	mA	
	CMOS input	I _{CC(S)CMOS}		100	μA	

Note 1: AC power supply current above 5MHz: 1mA/MHz.

TABLE 1-3: READ OPERATION AC CHARACTERISTICS

Parameter	Symbol	28C17A-15		28C17A-20		28C17A-25		Units	Conditions
		Min	Max	Min	Max	Min	Max		
Address to Output Delay	t_{ACC}	—	150	—	200	—	250	ns	$\overline{OE} = \overline{CE} = V_{IL}$
\overline{CE} to Output Delay	t_{CE}	—	150	—	200	—	250	ns	$\overline{OE} = V_{IL}$
\overline{OE} to Output Delay	t_{OE}	—	70	—	80	—	100	ns	$\overline{CE} = V_{IL}$
\overline{CE} or \overline{OE} High to Output Float	t_{OFF}	0	50	0	55	0	70	ns	
Output Hold from Address, \overline{CE} or \overline{OE} , whichever occurs first.	t_{OH}	0	—	0	—	0	—	ns	
Endurance	—	1M	—	1M	—	1M	—	cycles	25°C, $V_{CC} = 5.0V$, Block Mode (Note)

Note: This parameter is not tested but guaranteed by characterization. For endurance estimates in a specific application, please consult the Total Endurance Model which can be obtained on our BBS or website.

FIGURE 1-1: READ WAVEFORMS

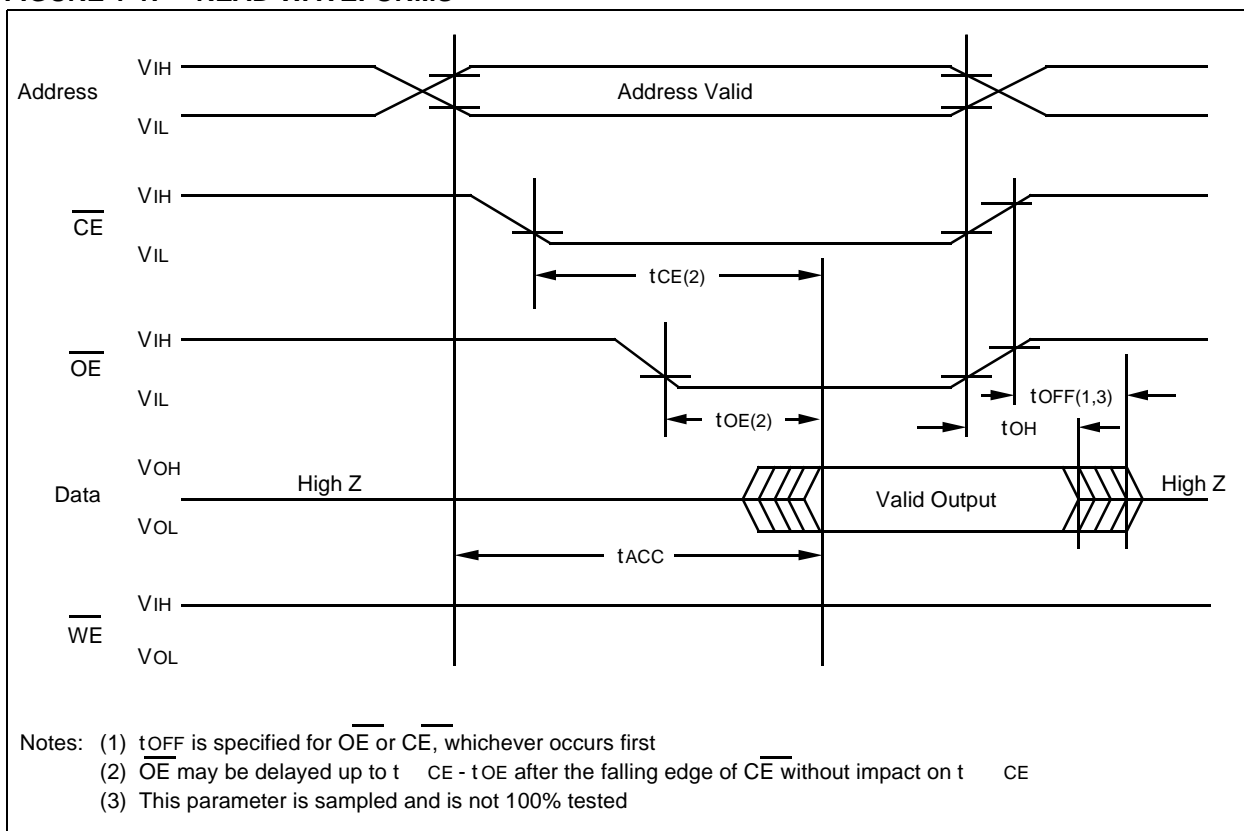

28C17A

TABLE 1-4: BYT E WRITE AC CHARACTERISTICS

Parameter	Symbol	Min	Max	Units	Remarks
AC Testing Waveform:		V _{IH} = 2.4V; V _{IL} = 0.45V; V _{OH} = 2.0V; V _{OL} = 0.8V			
Output Load:		1 TTL Load + 100 pF			
Input Rise/Fall Times:		20 ns			
Ambient Temperature:		Commercial (C): T _{amb} = 0°C to +70°C Industrial (I): T _{amb} = -40°C to +85°C			
Address Set-Up Time	t _{AS}	10	—	ns	
Address Hold Time	t _{AH}	50	—	ns	
Data Set-Up Time	t _{DS}	50	—	ns	
Data Hold Time	t _{DH}	10	—	ns	
Write Pulse Width	t _{WPL}	100	—	ns	Note 1
Write Pulse High Time	t _{WPH}	50	—	ns	
\overline{OE} Hold Time	t _{OEH}	10	—	ns	
\overline{OE} Set-Up Time	t _{OES}	10	—	ns	
Data Valid Time	t _{DV}	—	1000	ns	Note 2
Time to Device Busy	t _{DB}	2	50	ns	
Write Cycle Time (28C17A)	t _{WC}	—	1	ms	0.5 ms typical
Write Cycle Time (28C17AF)	t _{WC}	—	200	μs	100 μs typical

Note 1: A write cycle can be initiated by \overline{CE} or \overline{WE} going low, whichever occurs last. The data is latched on the positive edge of \overline{CE} or \overline{WE} , whichever occurs first.

Note 2: Data must be valid within 1000ns max. after a write cycle is initiated and must be stable at least until t_{DH} after the positive edge of \overline{WE} or \overline{CE} , whichever occurs first.

FIGURE 1-2: PROGRAMMING WAVEFORMS

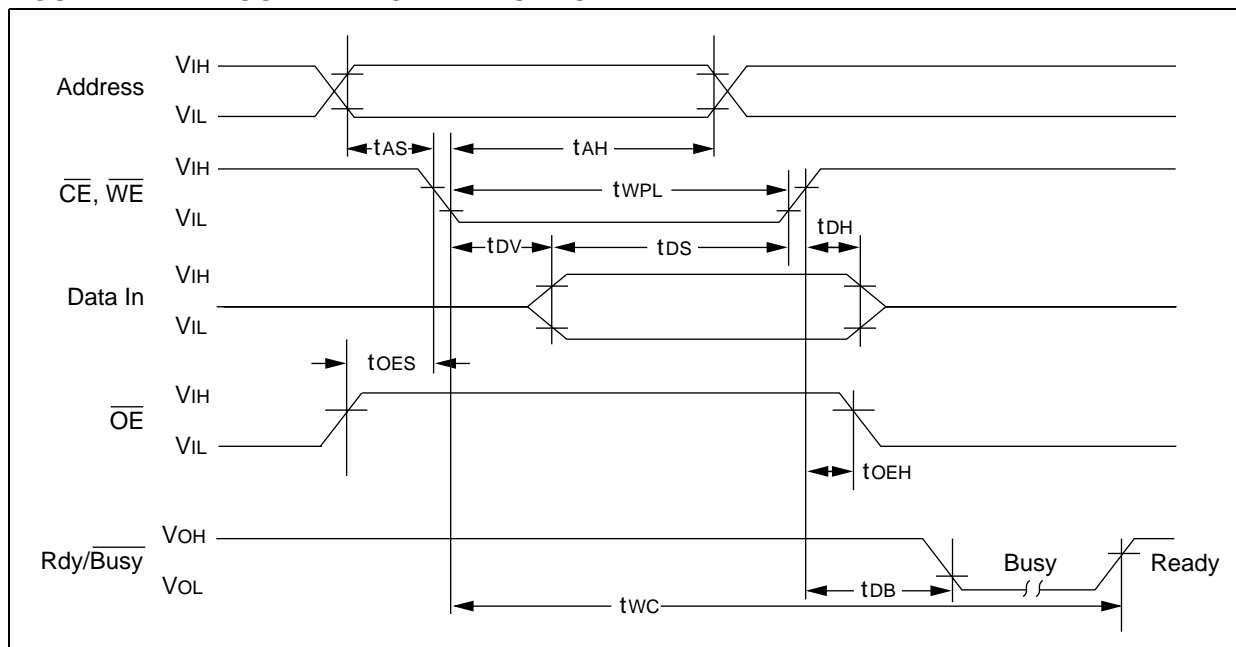

查询98C17A供应商 **FIGURE 1-3: DATA POLLING WAVEFORMS**

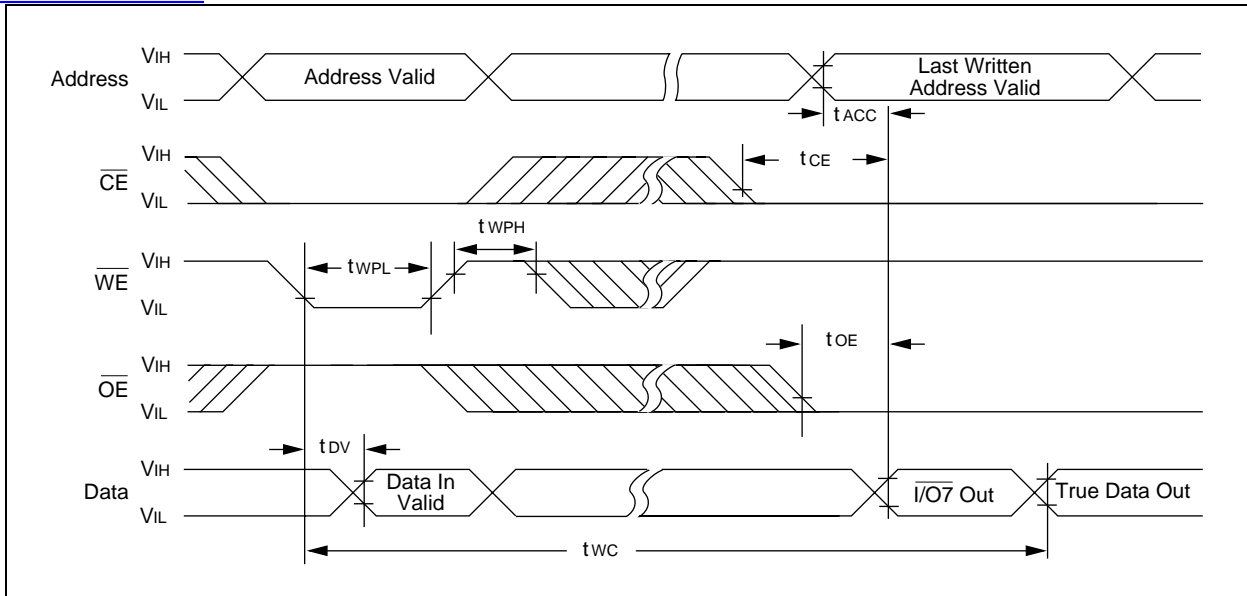

FIGURE 1-4: CHIP CLEAR WAVEFORMS

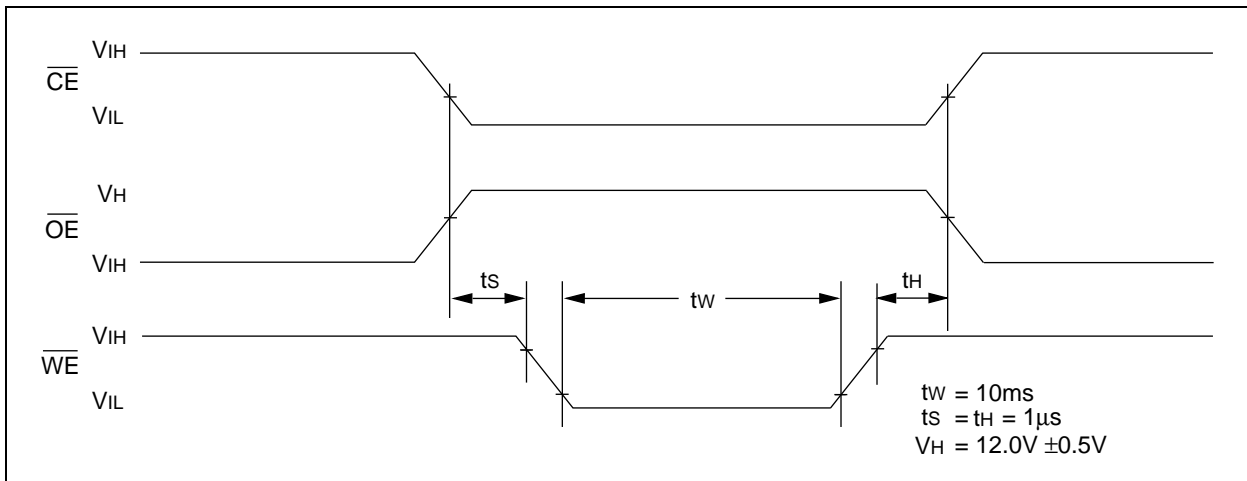

TABLE 1-5: SUPPLEMENTARY CONTROL

Mode	$\overline{\text{CE}}$	$\overline{\text{OE}}$	$\overline{\text{WE}}$	A9	Vcc	I/O _I
Chip Clear	VIL	VH	VIL	X	Vcc	
Extra Row Read	VIL	VIL	VIH	A9 = VH	Vcc	Data Out
Extra Row Write	*	VIH	*	A9 = VH	Vcc	Data In

Note 1: V_H = 12.0V ± 0.5V

* Pulsed per programming waveforms.

28C17A

2.0 DEVICE OPERATION

The Microchip Technology Inc. 28C17A has four basic modes of operation—read, standby, write inhibit, and byte write—as outlined in the following table.

Operation Mode	\overline{CE}	\overline{OE}	\overline{WE}	I/O	Rdy/Busy (1)
Read	L	L	H	DOUT	H
Standby	H	X	X	High Z	H
Write Inhibit	H	X	X	High Z	H
Write Inhibit	X	L	X	High Z	H
Write Inhibit	X	X	H	High Z	H
Byte Write	L	H	L	DIN	L
Byte Clear	Automatic Before Each "Write"				

Note 1: Open drain output.

2: X = Any TTL level.

2.1 Read Mode

The 28C17A has two control functions, both of which must be logically satisfied in order to obtain data at the outputs. Chip enable (\overline{CE}) is the power control and should be used for device selection. Output Enable (\overline{OE}) is the output control and is used to gate data to the output pins independent of device selection. Assuming that addresses are stable, address access time (t_{ACC}) equal to the delay from \overline{CE} to output (t_{CE}). Data is available at the output t_{OE} after the falling edge of \overline{OE} , assuming that CE has been low and addresses have been stable for at least t_{ACC} - t_{OE} .

2.2 Standby Mode

The 28C17A is placed in the standby mode by applying a high signal to the \overline{CE} input. When in the standby mode, the outputs are in a high impedance state, independent of the \overline{OE} input.

2.3 Data Protection

In order to ensure data integrity, especially during critical power-up and power-down transitions, the following enhanced data protection circuits are incorporated:

First, an internal VCC detect (3.3 volts typical) will inhibit the initiation of non-volatile programming operation when VCC is less than the VCC detect circuit trip.

Second, there is a \overline{WE} filtering circuit that prevents \overline{WE} pulses of less than 10 ns duration from initiating a write cycle.

Third, holding \overline{WE} or \overline{CE} high or \overline{OE} low, inhibits a write cycle during power-on and power-off (VCC).

2.4 Write Mode

The 28C17A has a write cycle similar to that of a Static RAM. The write cycle is completely self-timed and initiated by a low going pulse on the \overline{WE} pin. On the falling edge of \overline{WE} , the address information is latched. On rising edge, the data and the control pins (\overline{CE} and \overline{OE}) are latched. The Ready/Busy pin goes to a logic low level indicating that the 28C17A is in a write cycle which signals the microprocessor host that the system bus is free for other activity. When Ready/Busy goes back to a high, the 28C17A has completed writing and is ready to accept another cycle.

2.5 Data Polling

The 28C17A features \overline{Data} polling to signal the completion of a byte write cycle. During a write cycle, an attempted read of the last byte written results in the data complement of I/O7 (I/O0 to I/O6 are indeterminate). After completion of the write cycle, true data is available. \overline{Data} polling allows a simple read/compare operation to determine the status of the chip eliminating the need for external hardware.

2.6 Electronic Signature for Device Identification

An extra row of 32 bytes of EEPROM memory is available to the user for device identification. By raising A9 to 12V \pm 0.5V and using address locations 7E0 to 7FF, the additional bytes can be written to or read from in the same manner as the regular memory array.

2.7 Chip Clear

All data may be cleared to 1's in a chip clear cycle by raising \overline{OE} to 12 volts and bringing the \overline{WE} and \overline{CE} low. This procedure clears all data, except for the extra row.

[李河28C17A供应商](#)
28C17A Product Identification System

To order or to obtain information, e.g., on pricing or delivery, please use the listed part numbers, and refer to the factory or the listed sales offices.

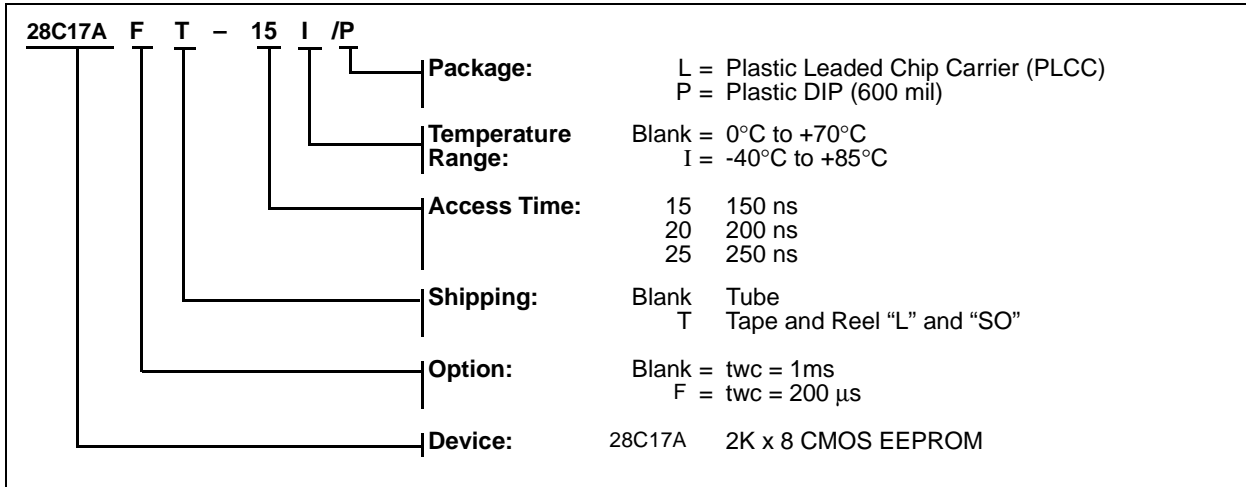

28C17A

[NOTES: 28C17A 供应商](#)

Note the following details of the code protection feature on Microchip devices:

- Microchip products meet the specification contained in their particular Microchip Data Sheet.
- Microchip believes that its family of products is one of the most secure families of its kind on the market today, when used in the intended manner and under normal conditions.
- There are dishonest and possibly illegal methods used to breach the code protection feature. All of these methods, to our knowledge, require using the Microchip products in a manner outside the operating specifications contained in Microchip's Data Sheets. Most likely, the person doing so is engaged in theft of intellectual property.
- Microchip is willing to work with the customer who is concerned about the integrity of their code.
- Neither Microchip nor any other semiconductor manufacturer can guarantee the security of their code. Code protection does not mean that we are guaranteeing the product as “unbreakable.”

Code protection is constantly evolving. We at Microchip are committed to continuously improving the code protection features of our products. Attempts to break Microchip's code protection feature may be a violation of the Digital Millennium Copyright Act. If such acts allow unauthorized access to your software or other copyrighted work, you may have a right to sue for relief under that Act.

Information contained in this publication regarding device applications and the like is intended through suggestion only and may be superseded by updates. It is your responsibility to ensure that your application meets with your specifications. No representation or warranty is given and no liability is assumed by Microchip Technology Incorporated with respect to the accuracy or use of such information, or infringement of patents or other intellectual property rights arising from such use or otherwise. Use of Microchip's products as critical components in life support systems is not authorized except with express written approval by Microchip. No licenses are conveyed, implicitly or otherwise, under any intellectual property rights.

Trademarks

The Microchip name and logo, the Microchip logo, Accuron, dsPIC, KEELOQ, microID, MPLAB, PIC, PICmicro, PICSTART, PRO MATE, PowerSmart, rfPIC, and SmartShunt are registered trademarks of Microchip Technology Incorporated in the U.S.A. and other countries.

AmpLab, FilterLab, MXDEV, MXLAB, PICMASTER, SEEVAL, SmartSensor and The Embedded Control Solutions Company are registered trademarks of Microchip Technology Incorporated in the U.S.A.

Analog-for-the-Digital Age, Application Maestro, dsPICDEM, dsPICDEM.net, dsPICworks, ECAN, ECONOMONITOR, FanSense, FlexROM, fuzzyLAB, In-Circuit Serial Programming, ICSP, ICEPIC, Migratable Memory, MPASM, MPLIB, MPLINK, MPSIM, PICkit, PICDEM, PICDEM.net, PICLAB, PICtail, PowerCal, PowerInfo, PowerMate, PowerTool, rfLAB, rfPICDEM, Select Mode, Smart Serial, SmartTel and Total Endurance are trademarks of Microchip Technology Incorporated in the U.S.A. and other countries.

SQTP is a service mark of Microchip Technology Incorporated in the U.S.A.

All other trademarks mentioned herein are property of their respective companies.

© 2004, Microchip Technology Incorporated, Printed in the U.S.A., All Rights Reserved.

 Printed on recycled paper.

**QUALITY MANAGEMENT SYSTEM
CERTIFIED BY DNV
== ISO/TS 16949:2002 ==**

Microchip received ISO/TS-16949:2002 quality system certification for its worldwide headquarters, design and wafer fabrication facilities in Chandler and Tempe, Arizona and Mountain View, California in October 2003. The Company's quality system processes and procedures are for its PICmicro® 8-bit MCUs, KEELOQ® code hopping devices, Serial EEPROMs, microperipherals, nonvolatile memory and analog products. In addition, Microchip's quality system for the design and manufacture of development systems is ISO 9001:2000 certified.

WORLDWIDE SALES AND SERVICE

AMERICAS

Corporate Office

2355 West Chandler Blvd.
Chandler, AZ 85224-6199
Tel: 480-792-7200
Fax: 480-792-7277
Technical Support: 480-792-7627
Web Address: www.microchip.com

Atlanta

3780 Mansell Road, Suite 130
Alpharetta, GA 30022
Tel: 770-640-0034
Fax: 770-640-0307

Boston

2 Lan Drive, Suite 120
Westford, MA 01886
Tel: 978-692-3848
Fax: 978-692-3821

Chicago

333 Pierce Road, Suite 180
Itasca, IL 60143
Tel: 630-285-0071
Fax: 630-285-0075

Dallas

16200 Addison Road, Suite 255
Addison Plaza
Addison, TX 75001
Tel: 972-818-7423
Fax: 972-818-2924

Detroit

Tri-Atria Office Building
32255 Northwestern Highway, Suite 190
Farmington Hills, MI 48334
Tel: 248-538-2250
Fax: 248-538-2260

Kokomo

2767 S. Albright Road
Kokomo, IN 46902
Tel: 765-864-8360
Fax: 765-864-8387

Los Angeles

25950 Acero St., Suite 200
Mission Viejo, CA 92691
Tel: 949-462-9523
Fax: 949-462-9608

San Jose

1300 Terra Bella Avenue
Mountain View, CA 94043
Tel: 650-215-1444
Fax: 650-961-0286

Toronto

6285 Northam Drive, Suite 108
Mississauga, Ontario L4V 1X5, Canada
Tel: 905-673-0699
Fax: 905-673-6509

ASIA/PACIFIC

Australia

Microchip Technology Australia Pty Ltd
Unit 32 41 Rawson Street
Epping 2121, NSW
Sydney, Australia
Tel: 61-2-9868-6733
Fax: 61-2-9868-6755

China - Beijing

Unit 706B
Wan Tai Bei Hai Bldg.
No. 6 Chaoyangmen Bei Str.
Beijing, 100027, China
Tel: 86-10-85282100
Fax: 86-10-85282104

China - Chengdu

Rm. 2401-2402, 24th Floor,
Ming Xing Financial Tower
No. 88 TIDU Street
Chengdu 610016, China
Tel: 86-28-86766200
Fax: 86-28-86766599

China - Fuzhou

Unit 28F, World Trade Plaza
No. 71 Wusi Road
Fuzhou 350001, China
Tel: 86-591-7503506
Fax: 86-591-7503521

China - Hong Kong SAR

Unit 901-6, Tower 2, Metroplaza
223 Hing Fong Road
Kwai Fong, N.T., Hong Kong
Tel: 852-2401-1200
Fax: 852-2401-3431

China - Shanghai

Room 701, Bldg. B
Far East International Plaza
No. 317 Xian Xia Road
Shanghai, 200051
Tel: 86-21-6275-5700
Fax: 86-21-6275-5060

China - Shenzhen

Rm. 1812, 18/F, Building A, United Plaza
No. 5022 Binhe Road, Futian District
Shenzhen 518033, China
Tel: 86-755-82901380
Fax: 86-755-8295-1393

China - Shunde

Room 401, Hongjian Building, No. 2
Fengxiangnan Road, Ronggui Town, Shunde
District, Foshan City, Guangdong 528303, China
Tel: 86-757-28395507 Fax: 86-757-28395571

China - Qingdao

Rm. B505A, Fullhope Plaza,
No. 12 Hong Kong Central Rd.
Qingdao 266071, China
Tel: 86-532-5027355 Fax: 86-532-5027205

India

Divyasree Chambers
1 Floor, Wing A (A3/A4)
No. 11, O'Shaughnessy Road
Bangalore, 560 025, India
Tel: 91-80-22290061 Fax: 91-80-22290062

Japan

Yusen Shin Yokohama Building 10F
3-17-2, Shin Yokohama, Kohoku-ku,
Yokohama, Kanagawa, 222-0033, Japan
Tel: 81-45-471- 6166 Fax: 81-45-471-6122

Korea

168-1, Youngbo Bldg. 3 Floor
Samsung-Dong, Kangnam-Ku
Seoul, Korea 135-882
Tel: 82-2-554-7200 Fax: 82-2-558-5932 or
82-2-558-5934

Singapore

200 Middle Road
#07-02 Prime Centre
Singapore, 188980
Tel: 65-6334-8870 Fax: 65-6334-8850

Taiwan

Kaohsiung Branch
30F - 1 No. 8
Min Chuan 2nd Road
Kaohsiung 806, Taiwan
Tel: 886-7-536-4816
Fax: 886-7-536-4817

Taiwan

Taiwan Branch
11F-3, No. 207
Tung Hua North Road
Taipei, 105, Taiwan
Tel: 886-2-2717-7175 Fax: 886-2-2545-0139

Taiwan

Taiwan Branch
13F-3, No. 295, Sec. 2, Kung Fu Road
Hsinchu City 300, Taiwan
Tel: 886-3-572-9526
Fax: 886-3-572-6459

EUROPE

Austria

Durisolstrasse 2
A-4600 Wels
Austria
Tel: 43-7242-2244-399
Fax: 43-7242-2244-393

Denmark

Regus Business Centre
Lautrup hoj 1-3
Ballerup DK-2750 Denmark
Tel: 45-4420-9895 Fax: 45-4420-9910

France

Parc d'Activite du Moulin de Massy
43 Rue du Saule Trapu
Batiment A - 1er Etage
91300 Massy, France
Tel: 33-1-69-53-63-20
Fax: 33-1-69-30-90-79

Germany

Steinheilstrasse 10
D-85737 Ismaning, Germany
Tel: 49-89-627-144-0
Fax: 49-89-627-144-44

Italy

Via Salvatore Quasimodo, 12
20025 Legnano (MI)
Milan, Italy
Tel: 39-0331-742611
Fax: 39-0331-466781

Netherlands

Waegenburghtplein 4
NL-5152 JR, Drunen, Netherlands
Tel: 31-416-690399
Fax: 31-416-690340

United Kingdom

505 Eskdale Road
Winnersh Triangle
Wokingham
Berkshire, England RG41 5TU
Tel: 44-118-921-5869
Fax: 44-118-921-5820