

Features

- For WiMAX and WiBro applications
- Usable bandwidth of 4 MHz
- Low loss
- High attenuation
- Single-ended or balanced operation
- Ceramic Surface Mount Package (SMP)
- Hermetic
- RoHS compliant (2002/95/EC), Pb-free 

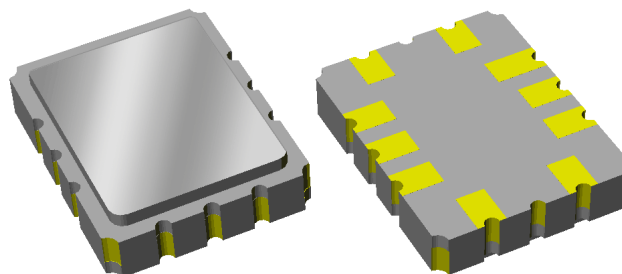

Package

Surface Mount 7.00 x 5.50 x 1.24 mm

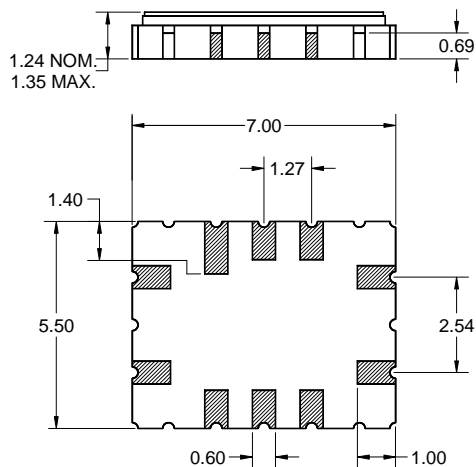

Pin Configuration

Bottom View

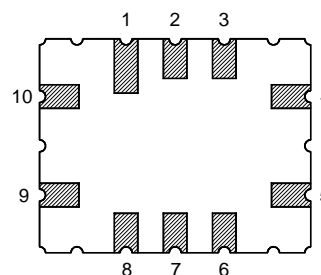

Pin No.	Description
4	Output
5	Output return
9	Input
10	Input return
1,2,3	Case ground
6,7,8	Case ground

Dimensions shown are nominal in millimeters
All tolerances are ± 0.15 mm except overall
length and width ± 0.13 mm

Body: Al_2O_3 ceramic
Lid: Kovar, Ni plated
Terminations: Au plating 0.5 - 1.0 μ m,
over a 2 - 6 μ m Ni plating

Electrical Specifications ⁽¹⁾

Operating Temperature Range: ⁽²⁾ -40 to +85°C

Parameter ⁽³⁾	Minimum	Typical	Maximum	Unit
Center Frequency (F ₀)	-	380	-	MHz
Maximum Insertion Loss		11	13	dB
Lower 1.5 dB Bandedge ⁽⁴⁾	-	377.53	377.90	MHz
Upper 1.5 dB Bandedge	382.1	382.56	-	MHz
Lower 10 dB Bandedge ⁽⁴⁾	376.75	377.00	-	MHz
Upper 10 dB Bandedge	-	382.95	383.25	MHz
Lower 20 dB Bandedge ⁽⁴⁾	376.35	376.83	-	MHz
Upper 20 dB Bandedge	-	383.18	383.65	MHz
Lower 30 dB Bandedge ⁽⁴⁾	375.85	376.41	-	MHz
Upper 30 dB Bandedge	-	383.62	384.15	MHz
Amplitude Variation ⁽⁵⁾ 377.9 - 382.1 MHz	-	0.82	1.5	dB p-p
Group Delay 377.9 - 382.1 MHz	-	0.67	-	μsec
Group Delay Variation ⁽⁵⁾ 377.9 - 382.1 MHz	-	42	120	nsec
Source Impedance (Balanced) ⁽⁶⁾	-	100	-	Ω
Load Impedance (Balanced) ⁽⁶⁾	-	100	-	Ω

Notes:

1. All specifications are based on the test circuit shown below
2. In production, devices will be tested at room temperature to a guardbanded specification to ensure electrical compliance over temperature
3. Electrical margin has been built into the design to account for the variations due to manufacturing tolerances
4. Relative to insertion loss at 380 MHz
5. Amplitude and group delay variation is the total over the defined frequency range
6. This is the optimal impedance in order to achieve the performance shown

Test Circuit:

Actual matching values may vary due to PCB layout and parasitics

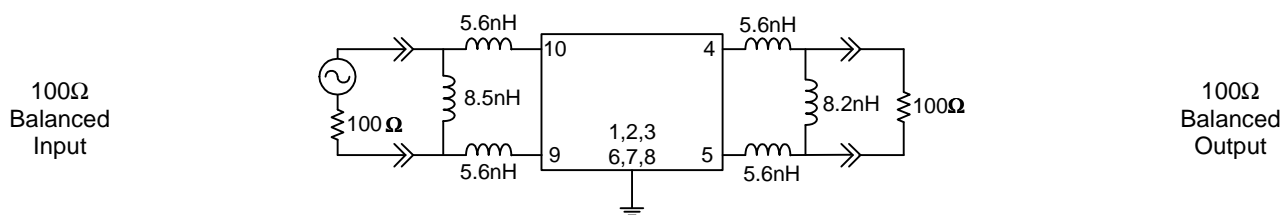

Typical Performance (at +25°C)

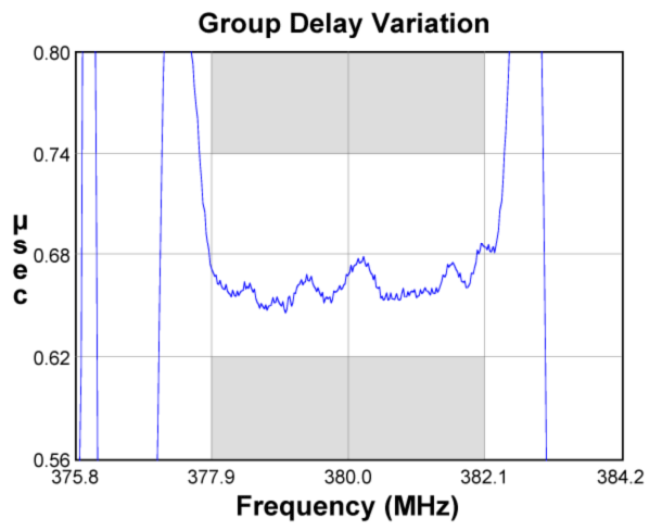
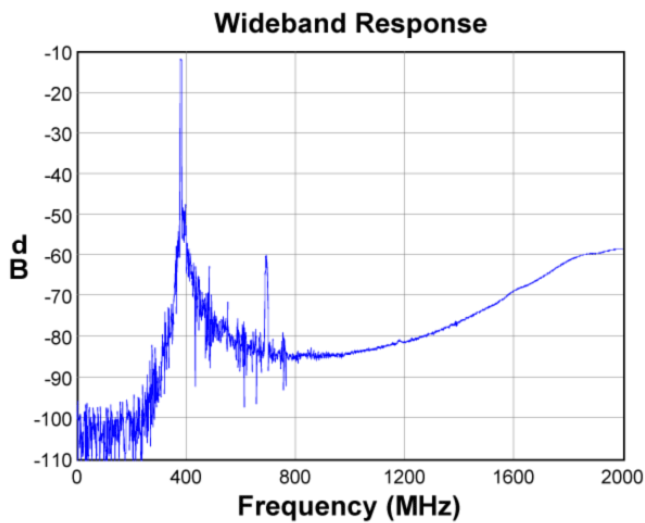
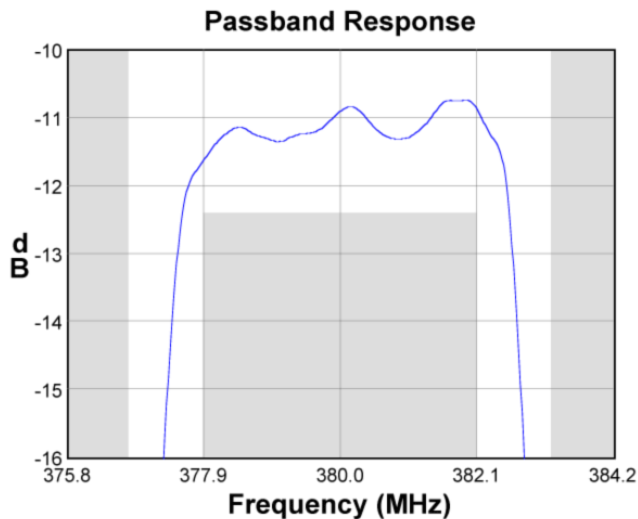
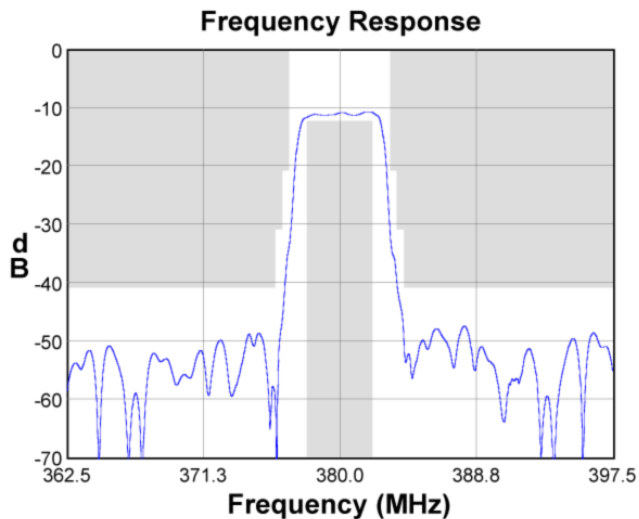

Input Smith Chart

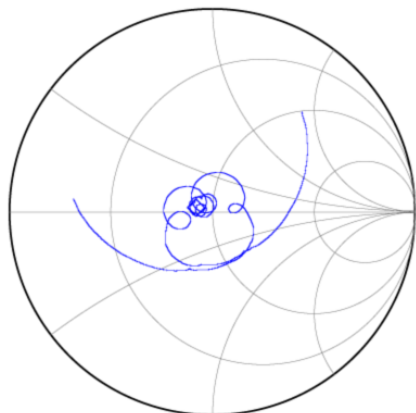

Output Smith Chart

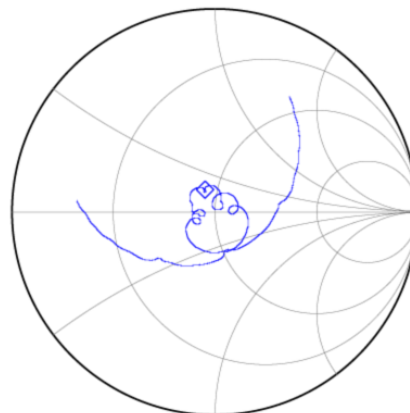

Matching Schematics

Actual matching values may vary due to PCB layout and parasitics

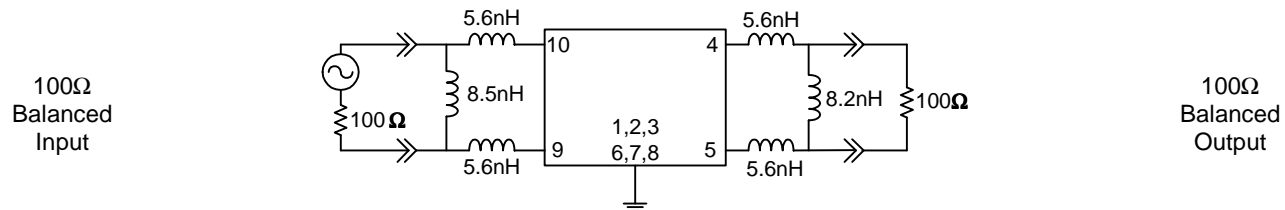

Marking

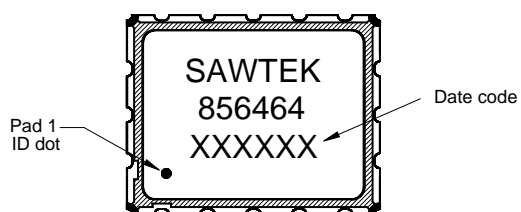

The date code consists of: day of the current year (Julian, 3 digits), last digit of the year (1 digit) and hour (2 digits)

PCB Footprint

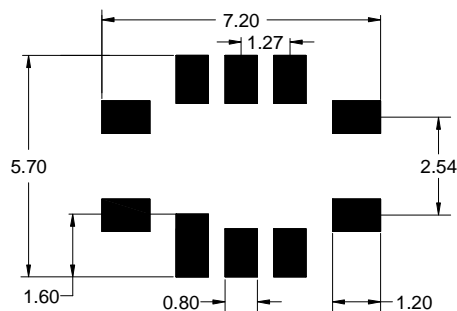

This footprint represents a recommendation only
Dimensions shown are nominal in millimeters

Tape and Reel

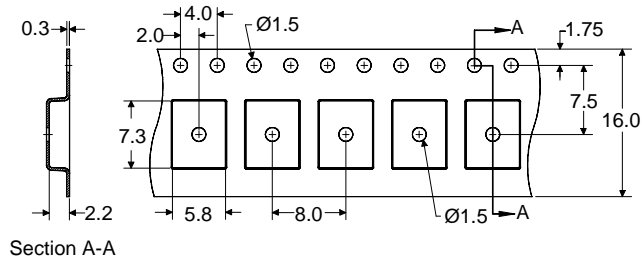
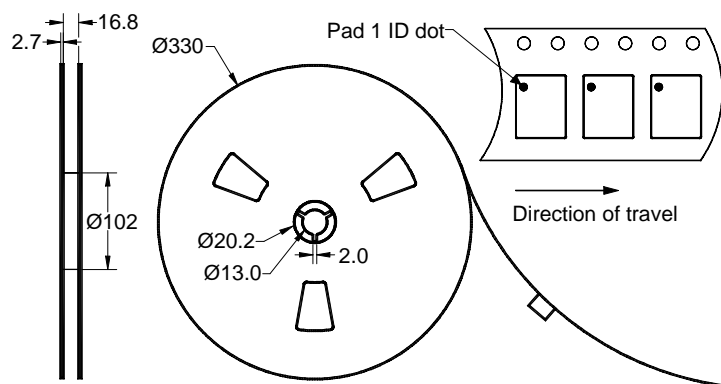

Dimensions shown are nominal in millimeters
Packaging quantity: 3000 units/reel

Maximum Ratings

Parameter	Symbol	Minimum	Maximum	Unit
Operating Temperature Range	T	-40	+85	°C
Storage Temperature Range	T _{stg}	-40	+85	°C

Warnings

- Electrostatic Sensitive Device (ESD)
- Avoid ultrasonic exposure



Material Content

- Does not contain lead (Pb) or other RoHS restricted materials



Links to Additional Technical Information

[PCB Layout Tips](#)

[Qualification Flowchart](#)

[Soldering Profile](#)

[S-Parameters](#)

[RoHS Information](#)

[Other Technical Information](#)

TriQuint's liability is limited only to the Surface Acoustic Wave (SAW) component(s) described in this data sheet. TriQuint does not accept any liability for applications, processes, circuits or assemblies which are implemented using any TriQuint component described in this data sheet.

Contact Information

TriQuint 
 SEMICONDUCTOR

PO Box 609501
 Orlando, FL 32860-9501
 USA

Phone: +1 (407) 886-8860
 Fax: +1 (407) 886-7061
 Email: info-product@tqs.com
 Web: www.triquint.com

Or contact one of our worldwide
 Network of [sales offices](#),
[Representatives or distributors](#)