

**3V Quad-Band GSM850/GSM900/DCS/PCS Power Amplifier Module**

**Functional Block Diagram**

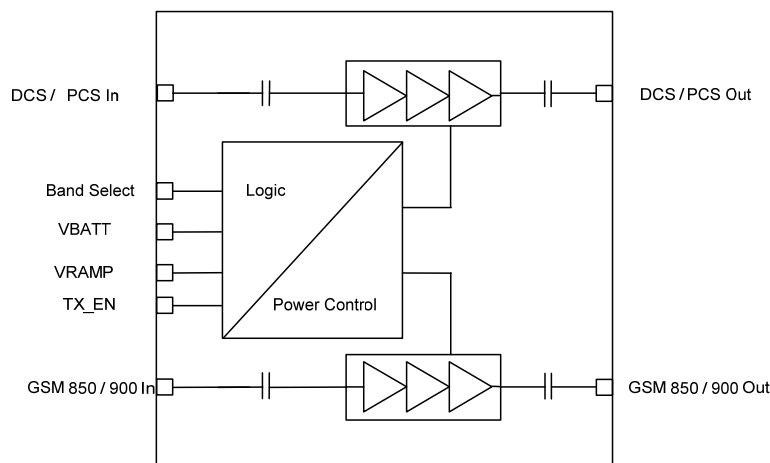

**Product Description**

The TQM7M4007 is an extremely small (5x5x1.0mm<sup>3</sup>) multi-mode power amplifier module for GSM/GPRS applications. This module has been optimized for high GSM/GPRS efficiency.

The module incorporates two highly integrated InGaP power amplifier die with a CMOS controller. The CMOS controller implements a fully integrated closed-loop power control within the module for GSM Operation. This eliminates the need for any external couplers, power detectors, current sensing etc., to assure the output power level. The latter is set directly from the V<sub>ramp</sub> input from the DAC. The module has Tx enable and band select. Module construction is a low-profile over-molded land-grid array on a halogen free laminate.

**Electrical Specifications**

Parameter	850 Band	900 Band	DCS Band	PCS Band	Units
	Typ	Typ	Typ	Typ	
GSM Pout	35	35	33	33	dBm
Efficiency	55	55	50	49	%
Pin	3	3	3	3	dBm

**Features**

- Very compact size – 5x5x1.0 mm<sup>3</sup>.
- High GSM efficiency – GSM 850 55%, GSM900 55%, DCS 50%, PCS 49%
- Positive supply voltage – 3.0 to 4.5 V
- 50 Ω input and output impedances
- GPRS class 12.
- CMOS band select and internal closed-loop power control for GSM Operation.
- High-reliability InGaP technology.
- Ruggedness 10:1
- No external Vref Required

**Applications**

- GSM/GPRS handsets
- GSM/GPRS wireless cards & data links

**Package Style**

Package Size: LGA 5 x 5 x 1.0 mm  
Top View

