

FEATURES

- Wide Input Voltage Operating Range from 2.5V to 40V
- Low Standby Current
- Current Limiting
- Output Switch Current of 1.5A
- Output Voltage Adjustable from 1.25 to 40V
- Frequency of Operation to 100kHz

APPLICATIONS

- Step-Up Converter
- Step-Down Converter
- Voltage Inverting Application

GENERAL DESCRIPTION

The AMS34063 series is a control circuit containing the basic functions required for DC-to-DC converters. The device consists of an internal temperature compensated reference, a comparator, a controlled duty cycle oscillator with an active current limit circuit, a driver and a high current output switch. Designed specifically to be incorporated in Step-Up, Step-Down and Voltage -Inverting applications, the AMS34063 requires a minimum number of external components.

The AMS34063 is available in the 8-lead plastic SOIC and 8-lead plastic DIP packages.

ORDERING INFORMATION

PACKAGE TYPE		OPER. TEMP RANGE
8 LEAD PDIP	8 LEAD SOIC	
AMS34063P	AMS34063S	-40°C to +85°C

PIN CONNECTIONS

8 LEAD SOIC/ 8 LEAD PDIP

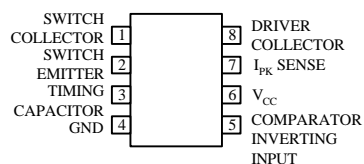

Top View

ABSOLUTE MAXIMUM RATINGS (Note 1)

Power Supply Voltage, V_{CC}	40V	Driver Collector Voltage, $V_{C(driver)}$	40V
Comparator Input Voltage Range, V_{IR}	-0.3V to +40V	Switch Current, I_{SW}	1.5A
Switch Collector Voltage, $V_{C(switch)}$	40V	Power Dissipation	(Note 3)
Switch Emitter Voltage, $V_{E(switch)}$	40V	Maximum Junction Temperature	+125°C
Switch Collector to Emitter Voltage, $V_{CE(switch)}$	40V	Storage Temperature	-65°C to +150°C

ELECTRICAL CHARACTERISTICS

Electrical Characteristics at $V_{CC} = 5.0V$, $-40^{\circ}C \leq T_A \leq +85^{\circ}C$, unless otherwise noted.

PARAMETER	CONDITIONS	AMS34063			Units
		Min.	Typ.	Max.	
Oscillator					
Charging Current	$5.0V \leq V_{CC} \leq 40V$, $T_A = 25^{\circ}C$	20	35	50	μA
Discharge Current	$5.0V \leq V_{CC} \leq 40V$, $T_A = 25^{\circ}C$	150	200	250	μA
Voltage Swing	$T_A = 25^{\circ}C$		0.5		V_{P-P}
Discharge to Charge Current Ratio	$I_{PK(sense)} = V_{CC}$, $T_A = 25^{\circ}C$		6.0		-
Current Limit Sense Voltage	$I_{CHG} = I_{DISCHG}$, $T_A = 25^{\circ}C$	250	300	350	mV
Output Switch (Note 2)					
Saturation Voltage, Darlington Connection	$I_{SW} = 1.0A$, $V_{C(driver)} = V_{C(switch)}$		1.0	1.3	V
Saturation Voltage	$I_{SW} = 1.0A$, $I_{C(driver)} = 50mA$, (Forced $\beta \approx 20$)		0.45	0.7	V
DC Current Gain	$I_{SW} = 1.0A$, $V_{CE} = 5.0V$, $T_A = 25^{\circ}C$		35	120	
Collector Off-State Current	$V_{CE} = 40V$, $T_A = 25^{\circ}C$		10		nA
Comparator					
Threshold Voltage		1.18	1.25	1.32	V
Threshold Voltage Line Regulation	$3.0V \leq V_{CC} \leq 40V$		0.04	0.2	mV/V
Input Bias Current	$V_{IN} = 0V$		40	400	nA
Total Device					
Supply Current	$5.0V \leq V_{CC} \leq 40V$, $I_{PK(sense)} = V_{CC}$, $C_T = 0.001\mu F$, V pin 5 > V_{th} , Pin 2 = Gnd, Remaining pins open		2.4	3.5	mA

Note 1: Absolute Maximum Ratings are limits beyond which damage to the device may occur. For guaranteed performance limits and associated test conditions, see the Electrical Characteristics tables.

Note 2: To minimize power dissipation, low duty cycle pulse testing is used.

Note 3: Power dissipation at $T_A = 25^{\circ}C$ is equal to 1.0W for the 8 lead P DIP package and 625mW for the SO-8 package. For operation at temperatures above $T_A = 25^{\circ}C$ derate the power dissipation at 10mW/ $^{\circ}C$.

FUNCTIONAL BLOCK DIAGRAM

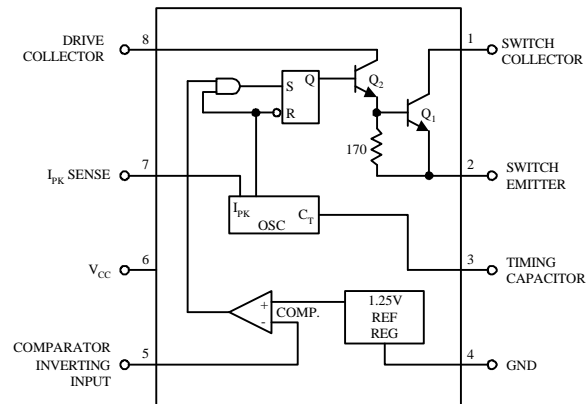

TYPICAL PERFORMANCE CHARACTERISTICS

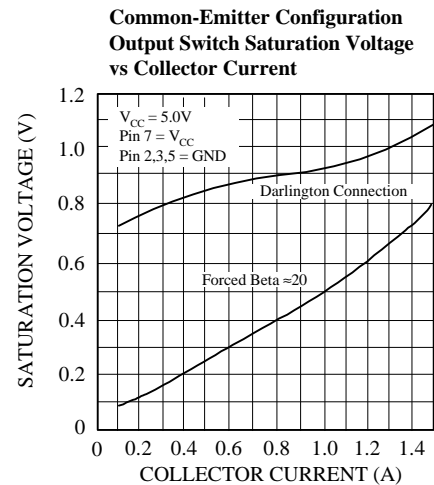
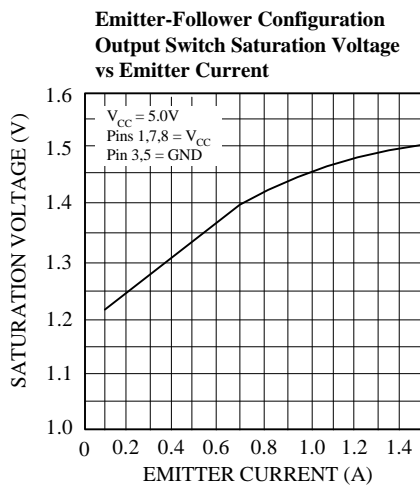
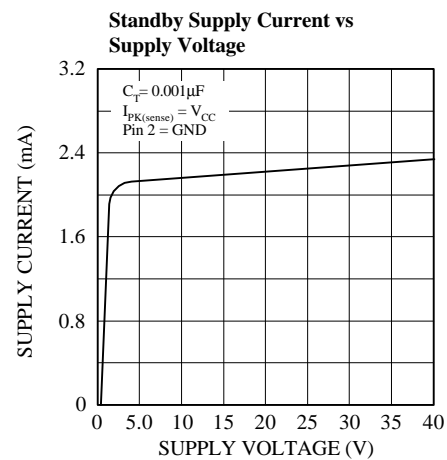
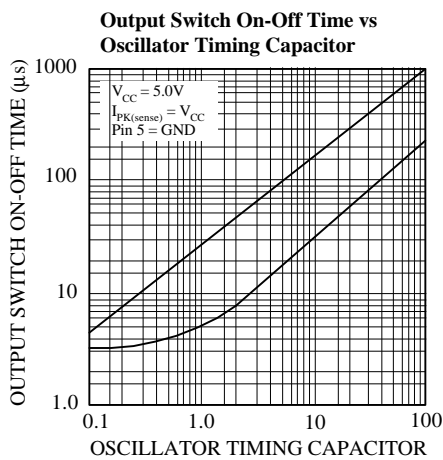

TYPICAL APPLICATIONS

Step-Down Converter

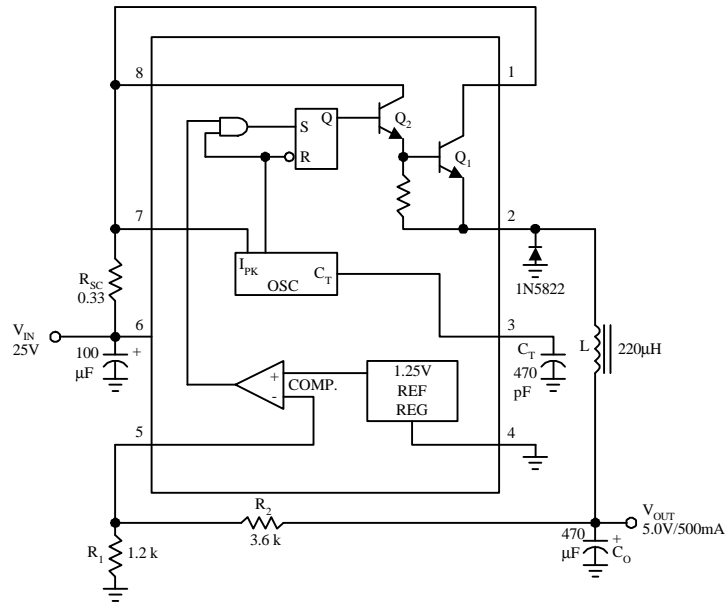

Test	Conditions	Results
Line Regulation	$V_{IN} = 15 \text{ to } 25\text{V}, I_O = 500\text{mA}$	15mV
Load Regulation	$V_{IN} = 25\text{V}, I_O = 50 \text{ to } 500\text{mA}$	5.0mV
Output Ripple	$V_{IN} = 25\text{V}, I_O = 500\text{mA}$	40 mV _{P-P}
Short Circuit Current	$V_{IN} = 25\text{V}, R_L = 0.1\Omega$	2.3A
Efficiency	$V_{IN} = 25\text{V}, I_O = 500\text{mA}$	84.7%

External Current Boost Connections for I_C Peak Greater than 1.5A

a. External NPN Switch

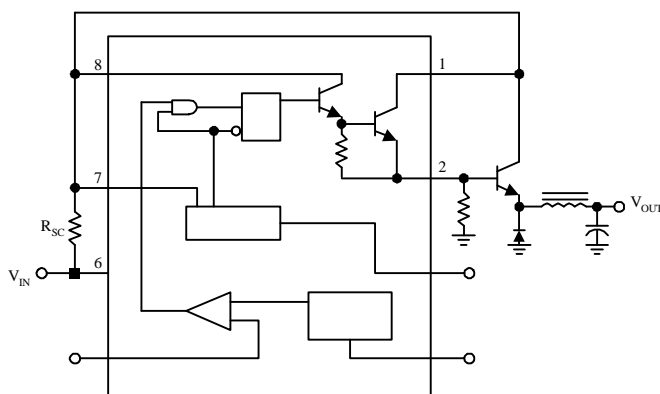

b. External PNP Saturated Switch

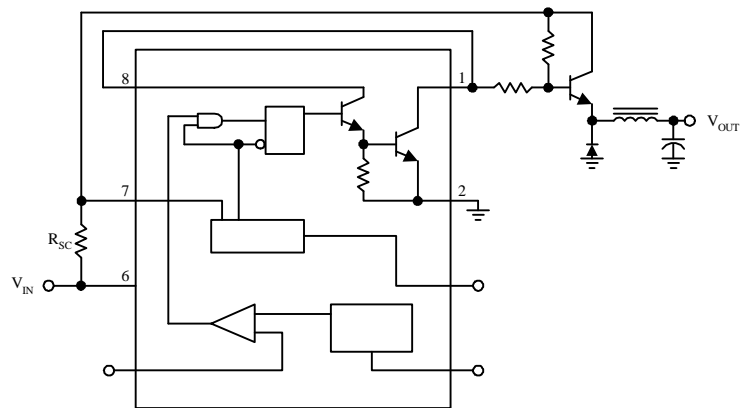

TYPICAL APPLICATIONS (Continued)

Step-Up Converter

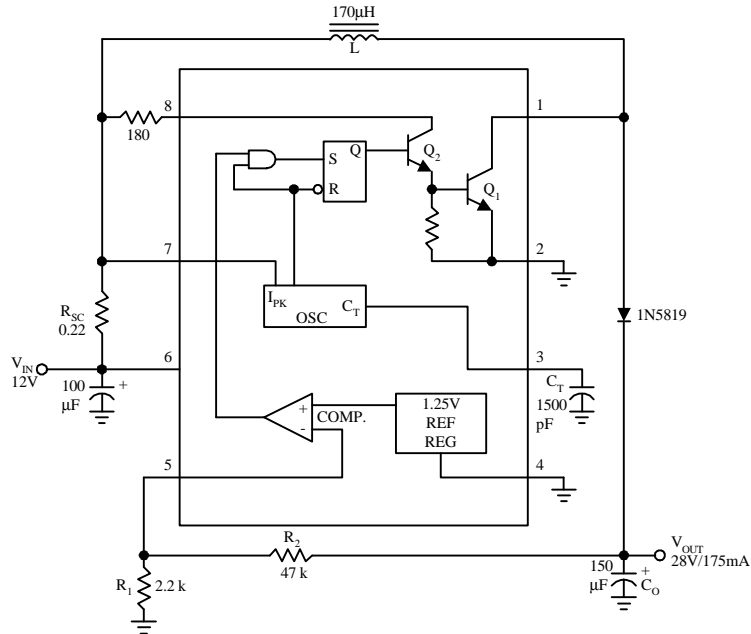

Test	Conditions	Results
Line Regulation	$V_{IN} = 8 \text{ to } 16\text{V}, I_O = 175 \text{ mA}$	12 mV
Load Regulation	$V_{IN} = 12\text{V}, I_O = 75 \text{ to } 175 \text{ mA}$	5.0 mV
Output Ripple	$V_{IN} = 12\text{V}, I_O = 175 \text{ mA}$	40 mV _{P-P}
Short Circuit Current	$V_{IN} = 12\text{V}, R_L = 0.1\Omega$	2.3A
Efficiency	$V_{IN} = 12\text{V}, I_O = 175 \text{ mA}$	84.7%

External Current Boost Connections for I_C Peak Greater than 1.5A

a. External NPN Switch

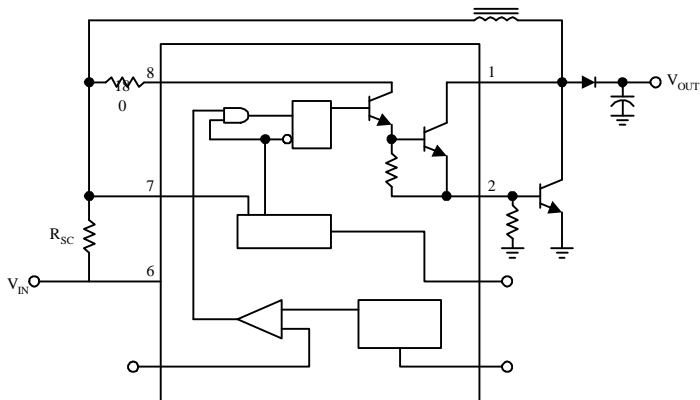

b. External NPN Saturated Switch

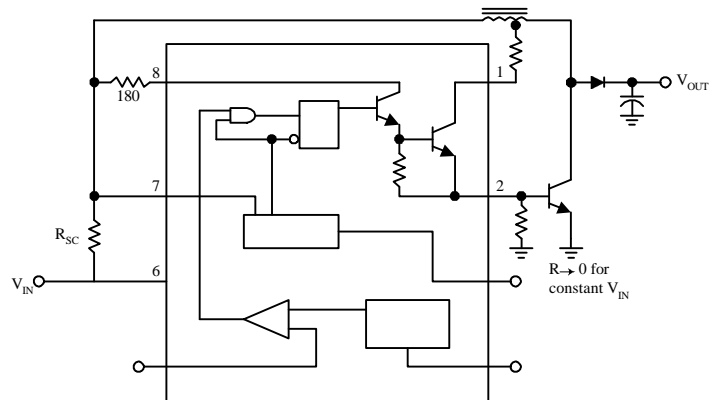

APPLICATION HINTS

Design Formula Table

Calculation	Step-Down	Step-Up
$\frac{t_{ON}}{t_{OFF}}$	$\frac{V_{OUT} + V_F}{V_{IN(MIN)} - V_{SAT} - V_{OUT}}$	$\frac{V_{OUT} + V_F - V_{IN(MIN)}}{V_{IN(MIN)} - V_{SAT}}$
$(t_{ON} + t_{OFF})_{MAX}$	$\frac{1}{f_{MIN}}$	$\frac{1}{f_{MIN}}$
C_T	$4 \times 10^{-5} t_{ON}$	$4 \times 10^{-5} t_{ON}$
$I_{PK(switch)}$	$2I_{OUT(MAX)}$	$2I_{OUT(MAX)} \left(\frac{t_{ON} + t_{OFF}}{t_{OFF}} \right)$
R_{SC}	$0.33/I_{PK(switch)}$	$0.33/I_{PK(switch)}$
$L_{(MIN)}$	$\left(\frac{V_{IN(MIN)} - V_{SAT} - V_{OUT}}{I_{PK(switch)}} \right) t_{ON(MAX)}$	$\left(\frac{V_{IN(MIN)} - V_{SAT}}{I_{PK(switch)}} \right) t_{ON(MAX)}$
C_O	$\frac{I_{PK(switch)} (t_{ON} + t_{OFF})}{8V_{ripple(P-P)}}$	$\approx \frac{I_{OUT} t_{ON}}{V_{ripple}}$

V_{SAT} = Saturation voltage of the output switch.

V_F = Forward voltage drop of the ringback rectifier.

Notes

The following power supply characteristics must be chosen:

V_{IN} – Nominal input voltage. If this voltage is not constant, then use $V_{IN(MAX)}$ for step-down and $V_{IN(MIN)}$ for step-up converter.

V_{OUT} – Desired output voltage, $V_{OUT} = 1.25 \left(1 + \frac{R_2}{R_1} \right)$.

I_{OUT} - Desired output current.

f_{MIN} - Minimum desired output switching frequency at the selected values for V_{IN} and I_O .

$V_{ripple(P-P)}$ – Desired peak-to-peak output ripple voltage. In practice, the calculated value will need to be increased due to the capacitor's equivalent series resistance and board layout. The ripple voltage should be kept to a low value since it will directly effect the line and load regulation.

PACKAGE DIMENSIONS inches (millimeters) unless otherwise noted.

8 LEAD SOIC PLASTIC PACKAGE (S)

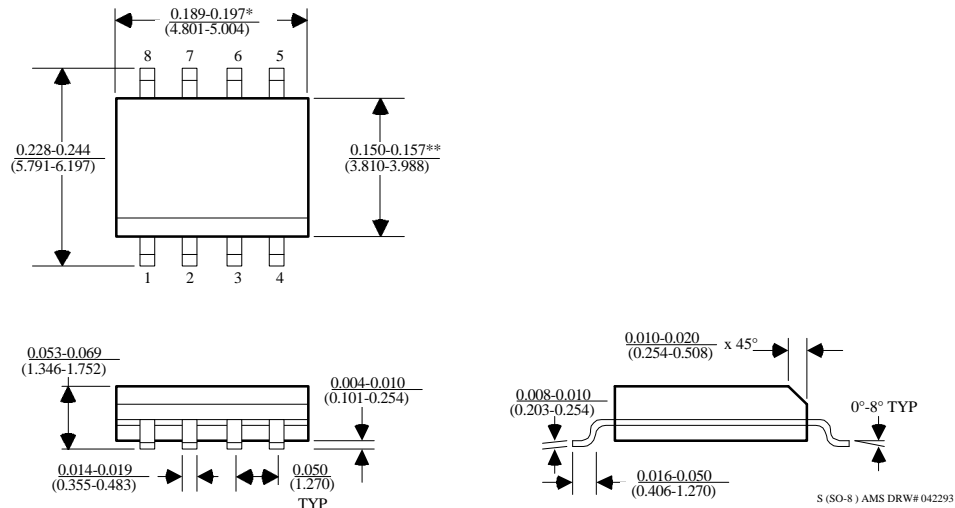

*DIMENSION DOES NOT INCLUDE MOLD FLASH. MOLD FLASH SHALL NOT EXCEED 0.006" (0.152mm) PER SIDE

**DIMENSION DOES NOT INCLUDE INTERLEAD FLASH. INTERLEAD FLASH SHALL NOT EXCEED 0.010" (0.254mm) PER SIDE

8 LEAD PLASTIC DIP PACKAGE (P)

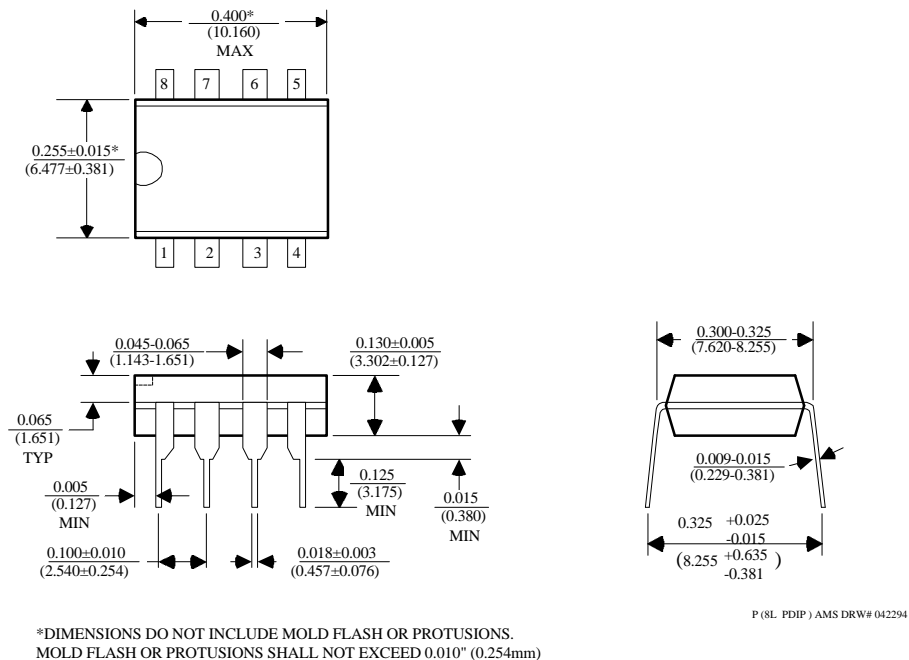

*DIMENSIONS DO NOT INCLUDE MOLD FLASH OR PROTUSIONS. MOLD FLASH OR PROTUSIONS SHALL NOT EXCEED 0.010" (0.254mm)