

24-bit 192kHz 2Vrms Multi-Channel CODEC

DESCRIPTION

The WM8595 is a high performance multi-channel audio CODEC with flexible input/output selection and digital and analogue volume control. Features include a 24-bit stereo ADC with digital gain control, two 24-bit DACs with independent volume control and clocking, and a range of input/output channel selection options with analogue volume control for flexible routing within current and future audio systems.

The WM8595 has a six stereo input selector which accepts input levels up to 2Vrms. One stereo input can be selected through an input mux to be routed through to the ADC.

The WM8595 outputs two stereo audio channels at line levels up to 2Vrms, driven from independent DACs. The DAC channels include independent digital volume control, and both stereo output channels include analogue volume control with soft ramp.

The WM8595 supports up to 2Vrms analogue inputs, 2Vrms outputs, with sample rates from 32kHz to 192kHz on the DACs, and 32kHz to 96kHz on the ADC.

The WM8595 is controlled via a serial interface with support for 2-wire and 3-wire control with full readback. Control of mute, emergency shutdown and reset can also be achieved by pin selection.

The WM8595 is ideal for audio applications requiring high performance and flexible routing options, including flat panel digital TV and DVD recorder.

The WM8595 is available in a 48-pin QFN package.

FEATURES

- Multi-channel CODEC with 6 stereo input selector and 2 stereo output selector
- 4-channel DAC, 2-channel ADC
- 6x2Vrms stereo input selector to ADC
- 2x2Vrms stereo output
- Audio performance
 - DAC: 100dB SNR typical ('A' weighted @ 48kHz)
 - DAC: -87dB THD typical
 - ADC: 96dB SNR typical ('A' weighted @ 48kHz)
 - ADC: -80dB THD typical
- Independent sampling rate for ADC and DACs possible
- DACs sampling frequency 32kHz – 192kHz
- ADC sampling frequency 32kHz – 96kHz
- DAC digital volume control +12dB to -100dB in 0.5dB steps
- ADC digital volume control from +30dB to -97dB in 0.5dB steps
- ADC input analogue boost control, selectable from 0dB, +3dB, +6dB and +12dB
- Output analogue volume control +6dB to -73.5dB in 0.5dB steps with zero cross or soft ramp to prevent pops and clicks
- Digital multiplexer to interface to multiple digital sources – DSP, HDMI, memory card
- 2-wire and 3-wire serial control interface with readback and hardware reset, mute and emergency shutdown pins
- ADC features master or slave clocking modes
- Programmable format audio data interface modes
 - I2S, LJ, RJ, DSP
- 3.3V / 9V analogue, 3.3V digital supply operation
- 48-pin QFN package

APPLICATIONS

- Digital Flat Panel TV
- DVD-RW
- Set Top Boxes

BLOCK DIAGRAM

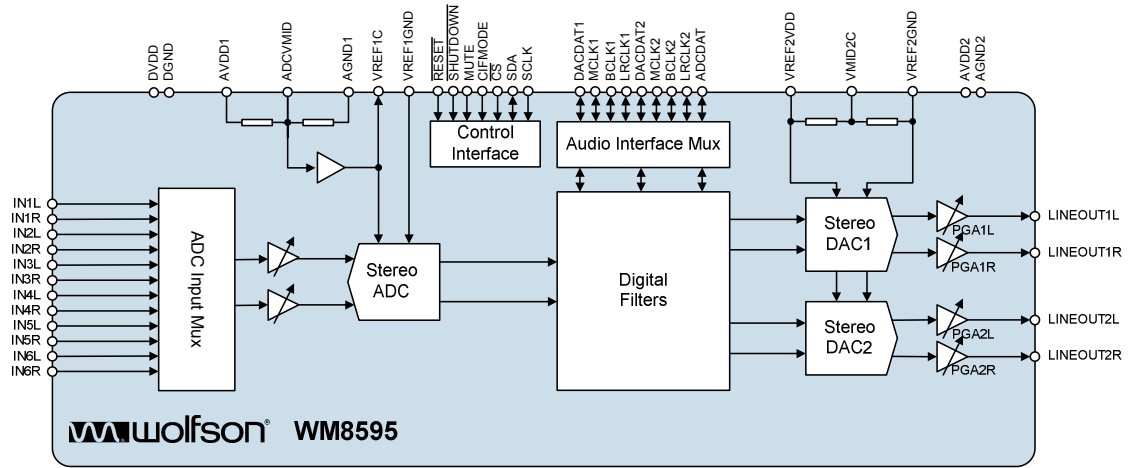
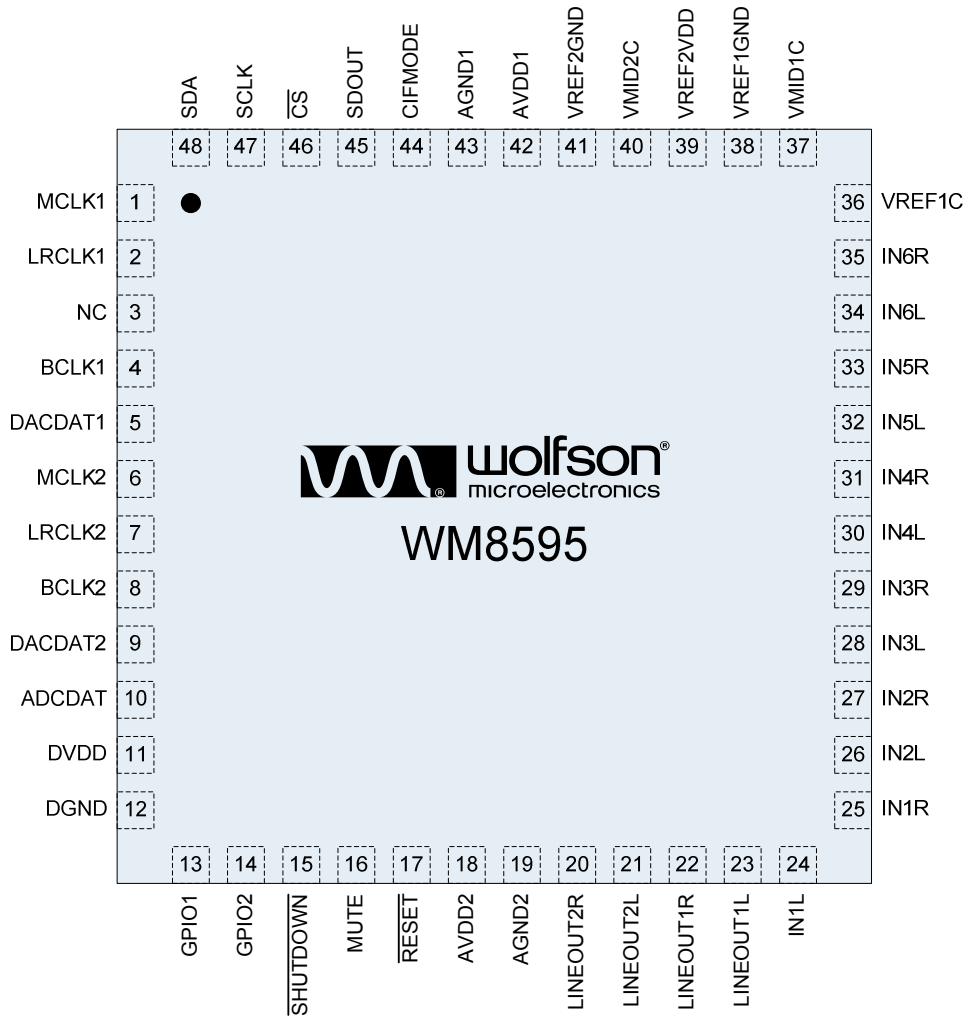

TABLE OF CONTENTS

DESCRIPTION	1
FEATURES	1
APPLICATIONS	1
BLOCK DIAGRAM	2
PIN CONFIGURATION	4
PIN DESCRIPTION	5
ABSOLUTE MAXIMUM RATINGS	6
RECOMMENDED OPERATING CONDITIONS	7
SUPPLY CURRENT CONSUMPTION	7
ELECTRICAL CHARACTERISTICS	8
TERMINOLOGY	10
MASTER CLOCK TIMING	11
RESET TIMING	11
DIGITAL AUDIO INTERFACE TIMING – SLAVE MODE	12
DIGITAL AUDIO INTERFACE TIMING – MASTER MODE.....	13
CONTROL INTERFACE TIMING – 2-WIRE MODE	14
CONTROL INTERFACE TIMING – 3-WIRE MODE	15
POWER ON RESET (POR)	16
DEVICE DESCRIPTION	17
INTRODUCTION	17
CONTROL INTERFACE.....	18
2-WIRE (SM-BUS COMPATIBLE) SERIAL CONTROL INTERFACE MODE	18
3-WIRE (SPI COMPATIBLE) SERIAL CONTROL INTERFACE MODE	20
DIGITAL AUDIO DATA FORMATS	21
DIGITAL AUDIO INTERFACE	26
DIGITAL AUDIO DATA SAMPLING RATES.....	28
DAC FEATURES.....	29
ANALOGUE OUTPUT VOLUME CONTROL.....	32
ADC FEATURES.....	36
DIGITAL ROUTING CONTROL.....	40
POP AND CLICK PERFORMANCE	46
GLOBAL ENABLE CONTROL.....	48
EMERGENCY POWER DOWN.....	49
REGISTER MAP	50
DIGITAL FILTER CHARACTERISTICS	74
APPLICATIONS INFORMATION	78
RECOMMENDED EXTERNAL COMPONENTS	78
RECOMMENDED ANALOGUE LOW PASS FILTER	79
RELEVANT APPLICATION NOTES	79
PACKAGE DIMENSIONS	80
IMPORTANT NOTICE	81
ADDRESS	81

PIN CONFIGURATION



ORDERING INFORMATION

ORDER CODE	TEMPERATURE RANGE	PACKAGE	MOISTURE SENSITIVITY LEVEL	PACKAGE BODY TEMPERATURE
WM8595GEFLV	-40°C to +85°C	48-lead QFN (Pb-free)	MSL3	260°C
WM8595GEFLRV	-40°C to +85°C	48-lead QFN (Pb-free, tape and reel)	MSL3	260°C

Note:

Reel quantity = 2200

PIN DESCRIPTION

PIN	NAME	TYPE	DESCRIPTION
1	MCLK1	Digital Input/Output	Audio interface port 1 master clock input/output
2	LRCLK1	Digital Input/Output	Audio interface port 1 left/right clock input/output
3	N/C		No internal connection
4	BCLK1	Digital Input/Output	Audio interface port 1 bit clock input/output
5	DACDAT1	Digital Input	Audio interface port 1 data input for DAC1
6	MCLK2	Digital Input/Output	Audio interface port 2 master clock input/output
7	LRCLK2	Digital Input/Output	Audio interface port 2 left/right clock input/output
8	BCLK2	Digital Input/Output	Audio interface port 2 bit clock input/output
9	DACDAT2	Digital Input	Audio interface port 2 data input for DAC2
10	ADCDAT	Digital Output	Audio interface port 3 data output for ADC
11	DVDD	Supply	Digital supply
12	DGND	Supply	Digital ground
13	GPIO1	Digital Input/Output	General purpose input/output 1
14	GPIO2	Digital Input/Output	General purpose input/output 2
15	SHUTDOWN	Digital Input	Emergency shutdown
16	MUTE	Digital Input	Hardware DAC mute
17	RESET	Digital Input	Hardware reset
18	AVDD2	Supply	Analogue 9V supply
19	AGND2	Supply	Analogue 9V ground
20	LINEOUT2R	Analogue Output	Output channel 2 right
21	LINEOUT2L	Analogue Output	Output channel 2 left
22	LINEOUT1R	Analogue Output	Output channel 1 right
23	LINEOUT1L	Analogue Output	Output channel 1 left
24	IN1L	Analogue Input	Input channel 1 left
25	IN1R	Analogue Input	Input channel 1 right
26	IN2L	Analogue Input	Input channel 2 left
27	IN2R	Analogue Input	Input channel 2 right
28	IN3L	Analogue Input	Input channel 3 left
29	IN3R	Analogue Input	Input channel 3 right
30	IN4L	Analogue Input	Input channel 4 left
31	IN4R	Analogue Input	Input channel 4 right
32	IN5L	Analogue Input	Input channel 5 left
33	IN5R	Analogue Input	Input channel 5 right
34	IN6L	Analogue Input	Input channel 6 left
35	IN6R	Analogue Input	Input channel 6 right
36	VREF1C	Analogue Output	Positive reference for ADC
37	VMID1C	Analogue Output	Midrail divider decoupling pin for ADC
38	VREF1GND	Analogue Input	Ground reference for ADC
39	VREF2VDD	Analogue Input	Positive reference for DACs
40	VMID2C	Analogue Output	Midrail divider decoupling pin for DACs
41	VREF2GND	Analogue Input	Ground reference for DACs
42	AVDD1	Supply	Analogue 3.3V supply
43	AGND1	Supply	Analogue 3.3V ground
44	CIFMODE	Digital Input	2-wire/3-wire mode select
45	SDOUT	Digital Output	Serial Data output for 3-wire readback
46	CS	Digital Input	3-wire serial control interface latch
47	SCLK	Digital Input	Software mode: serial control interface clock signal
48	SDA	Digital Input	Software mode: bi-directional serial control interface data signal

ABSOLUTE MAXIMUM RATINGS

Absolute Maximum Ratings are stress ratings only. Permanent damage to the device may be caused by continuously operating at or beyond these limits. Device functional operating limits and guaranteed performance specifications are given under Electrical Characteristics at the test conditions specified.



ESD Sensitive Device. This device is manufactured on a CMOS process. It is therefore generically susceptible to damage from excessive static voltages. Proper ESD precautions must be taken during handling and storage of this device.

Wolfson tests its package types according to IPC/JEDEC J-STD-020B for Moisture Sensitivity to determine acceptable storage conditions prior to surface mount assembly. These levels are:

MSL1 = unlimited floor life at <30°C / 85% Relative Humidity. Not normally stored in moisture barrier bag.

MSL2 = out of bag storage for 1 year at <30°C / 60% Relative Humidity. Supplied in moisture barrier bag.

MSL3 = out of bag storage for 168 hours at <30°C / 60% Relative Humidity. Supplied in moisture barrier bag.

The Moisture Sensitivity Level for each package type is specified in Ordering Information.

CONDITION	MIN	MAX
Digital supply voltage, DVDD	-0.3V	+4.5V
Analogue supply voltage, AVDD1	-0.3V	+7V
Analogue supply voltage, AVDD2	-0.3V	+15V
Voltage range digital inputs	DGND -0.3V	DVDD + 0.3V
Voltage range analogue inputs	AGND - 2.4V	AVDD1 + 2.4V
Master Clock Frequency		38.462MHz
Ambient temperature (supplies applied)	-55°C	+125°C
Storage temperature	-65°C	+150°C
Pb free package body temperature (reflow 10 seconds)		+260°C
Package body temperature (soldering 2 minutes)		+183°C

Note:

1. Analogue and digital grounds must always be within 0.3V of each other.

THERMAL PERFORMANCE

PARAMETER	SYMBOL	TEST CONDITIONS	MIN	TYP	MAX	UNIT
Thermal resistance – junction to ambient	$R_{\theta JA}$			TBD		°C/W
Thermal resistance – junction to case	$R_{\theta JC}$			TBD		°C/W

Notes:

1. Figures given for package mounted on 4-layer FR4 according to JESD51-7. (No forced air flow is assumed).
2. Thermal performance figures are estimated.

RECOMMENDED OPERATING CONDITIONS

PARAMETER	SYMBOL	TEST CONDITIONS	MIN	TYP	MAX	UNIT
Digital power supply	DVDD		2.97	3.3	3.6	V
Analogue power supply	AVDD1		2.97	3.3	3.6	V
Analogue power supply	AVDD2		8.1	9	9.9	V
Ground	DGND/AGND1/ AGND2			0		V
Operating temperature range	T _A		-40		+85	°C

Notes:

- Digital supply (DVDD) must never be more than 0.3V greater than AVDD1 in normal operation.
- Digital ground (DGND) and analogue grounds (AGND1, AGND2) must never be more than 0.3V apart.

SUPPLY CURRENT CONSUMPTION**Test Conditions**

AVDD2=9V, AVDD1=DVDD=3.3V, AGND1=AGND2=0V, DGND=0V, T_A=+25°C, fs=48kHz, MCLK=256fs unless otherwise stated

PARAMETER	SYMBOL	TEST CONDITIONS	MIN	TYP	MAX	UNIT
ADC Record (DACs disabled)						
Digital supply current	I _{DVDD}	fs=48kHz, 256fs Quiescent		8.6		mA
Analogue supply 1 current	I _{AVDD1}			9.2		mA
Analogue supply 2 current	I _{AVDD2}			0.01		mA
DAC Playback (ADC disabled, one DAC disabled)						
Digital supply current	I _{DVDD}	fs=48kHz, 256fs Quiescent		5.5		mA
Analogue supply 1 current	I _{AVDD1}			6.5		mA
Analogue supply 2 current	I _{AVDD2}			2.0		mA
Digital supply current	I _{DVDD}	fs=96kHz, 256fs Quiescent		9.5		mA
Analogue supply 1 current	I _{AVDD1}			7.0		mA
Analogue supply 2 current	I _{AVDD2}			2.0		mA
Digital supply current	I _{DVDD}	fs=192kHz, 256fs Quiescent		10.0		mA
Analogue supply 1 current	I _{AVDD1}			7.0		mA
Analogue supply 2 current	I _{AVDD2}			2.0		mA
ADC Record, DAC Playback (all circuit blocks enabled)						
Digital supply current	I _{DVDD}	fs=48kHz, 256fs Quiescent		17.0		mA
Analogue supply 1 current	I _{AVDD1}			20.0		mA
Analogue supply 2 current	I _{AVDD2}			11.0		mA

ELECTRICAL CHARACTERISTICS

Test Conditions

AVDD2=9V, AVDD1=DVDD=3.3V, AGND1=AGND2=0V, DGND=0V, T_A=+25°C, 1kHz signal, f_s=48kHz, MCLK=256fs unless otherwise stated

PARAMETER	SYMBOL	TEST CONDITIONS	MIN	TYP	MAX	UNIT
Digital logic levels						
Input low level	V _{IL}				0.3x DVDD	V
Input high level	V _{IH}		0.7x DVDD			V
Output low level	V _{OL}				0.1 x DVDD	V
Output high level	V _{OH}		0.9 x DVDD			V
Digital input leakage current				±0.2		µA
Digital input capacitance				5		pF
Analogue Reference Levels						
ADC Midrail Voltage	VMID1C			AVDD1/2		V
ADC Buffered Positive Reference Voltage	VREF1C			VMID1C		V
DAC Midrail Voltage	VMID2C			VREF2VDD/2		V
Potential divider resistance		AVDD1 to VMID1C VMID1C to AGND1		100		kΩ
		VREF2VDD to VMID2C VMID2C to VREF2GND VMID_SEL[1:0] = 01		19 (Note 2)		kΩ
Analogue Line Outputs						
Output signal level (0dB)			-10%	2.0x AVDD1/3.3	+10%	V _{rms}
Maximum capacitance load					11	nF
Minimum resistance load			1			kΩ
Analogue Inputs						
Input signal level (0dB)				2.0 x AVDD1/3.3		V _{rms}
Input impedance				48		kΩ
Input capacitance				5		pF
DAC Performance (DAC1 to LINEOUT1L/R, DAC2 to LINEOUT2L/R)						
Signal to Noise Ratio ^{1,5}	SNR	A-weighted @ f _s = 48kHz	90	100		dB
		A-weighted @ f _s = 96kHz		100		dB
		A-weighted @ f _s = 192kHz		100		dB
Dynamic Range ^{2,5}	DNR	A-weighted, -60dB full scale input	90	100		dB
Total Harmonic Distortion ^{3,5}	THD	1kHz, 0dBFS @ f _s = 48kHz		-87	-80	dB
		1kHz, 0dBFS @ f _s = 96kHz		-86		dB
		1kHz, 0dBFS @ f _s = 192kHz		-85		dB
Channel Separation ^{4,5}		1kHz		110		dB
Channel Level Matching				0.1		dB
Channel Phase Deviation		1kHz		0.01		Degree
Power supply rejection ratio	PSRR	1kHz, 100mVpp		50		dB
		20Hz to 20kHz, 100mVpp		45		dB

Test ConditionsAVDD2=9V, AVDD1=DVDD=3.3V, AGND1=AGND2=0V, DGND=0V, T_A=+25°C, 1kHz signal, fs=48kHz, MCLK=256fs unless otherwise stated

PARAMETER	SYMBOL	TEST CONDITIONS	MIN	TYP	MAX	UNIT
ADC Performance						
Signal to Noise Ratio ^{1,5}	SNR	A-weighted, 0dB gain @ fs = 48kHz	85	96		dB
		A-weighted, 0dB gain @ fs = 96kHz		98		dB
Dynamic Range ^{2,5}	DNR	A-weighted, -60dB full scale input	85	96		dB
Total Harmonic Distortion ^{3,5}	THD	1kHz, -1dBFS @ fs = 48kHz		-80	-70	dB
		1kHz, -1dBFS @ fs = 96kHz		-78		dB
Channel Separation ^{4,5}		1kHz		110		dB
Channel Level Matching				0.1		dB
Channel Phase Deviation		1kHz		0.01		Degree
Power Supply Rejection Ratio	PSRR	1kHz, 100mVpp		70		dB
		20Hz to 20kHz, 100mVpp		52		dB
Digital Volume Control						
ADC minimum digital volume				-97		dB
ADC maximum digital volume				+30		dB
ADC volume step size				0.5		dB
DAC minimum digital volume				-100		dB
DAC maximum digital volume				+12		dB
DAC volume step size				0.5		dB
Analogue Volume Control						
Minimum gain				-73.5		dB
Maximum gain				+6		dB
Step size				0.5		dB
Mute attenuation				120		dB
Crosstalk						
DAC to ADC		1kHz signal, ADC fs=48kHz, DAC fs=44.1kHz		100		dB
		20kHz signal, ADC fs=48kHz, DAC fs=44.1kHz		100		dB
ADC to DAC		1kHz signal, ADC fs=48kHz, DAC fs=44.1kHz		100		dB
		20kHz signal, ADC fs=48kHz, DAC fs=44.1kHz		100		dB

TERMINOLOGY

1. Signal-to-noise ratio (dBFS) – SNR is the difference in level between a reference full scale output signal and the device output with no signal applied. This ratio is also called idle channel noise. (No Auto-zero or Automute function is employed in achieving these results).
2. Dynamic range (dBFS) – DNR is a measure of the difference in level between the highest and lowest components of a signal. Normally a THD measurement at -60dBFS. The measured signal is then corrected by adding 60dB to the result, e.g. THD @ -60dBFS = -30dB, DNR = 90dB.
3. Total Harmonic Distortion (dBFS) – THD is the difference in level between a reference full scale output signal and the first seven odd harmonics of the output signal. To calculate the ratio, the fundamental frequency of the output signal is notched out and an RMS value of the next seven odd harmonics is calculated.
4. Channel Separation (dB) – Also known as Cross-Talk. This is a measure of the amount one channel is isolated from the other. Normally measured by sending a full scale signal down one channel and measuring the other.
5. All performance measurements carried out with 20kHz low pass filter, and where noted an A-weighted filter. Failure to use such a filter will result in higher THD and lower SNR and Dynamic Range readings than are found in the Electrical Characteristics. The low pass filter removes out of band noise; although it is not audible it may affect dynamic specification values.

Notes:

1. All minimum and maximum values are subject to change.
2. This resistance is selectable using VMID_SEL[1:0] – see Figure 47 for full details.
3. See p81 for details of extended input impedance configuration.

MASTER CLOCK TIMING

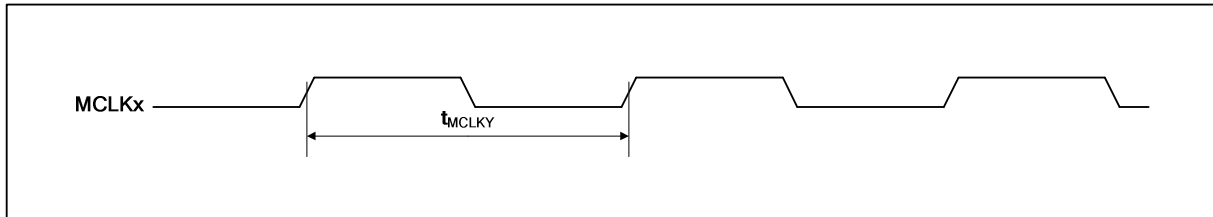

Figure 1 MCLK Timing

Test Conditions

AVDD1, DVDD = 3.3V, AVDD2 = 9V, AGND1, AGND2, DGND = 0V, $T_A = +25^{\circ}C$

PARAMETER	SYMBOL	MIN	TYP	MAX	UNIT
Master Clock Timing Information					
MCLK System clock cycle time	t_{MCLKY}	27		120	ns
MCLK Duty cycle		40:60		60:40	%
MCLK Period Jitter				200	ps
MCLK Rise/Fall times				10	ns

Table 1 Master Clock Timing Requirements

RESET TIMING

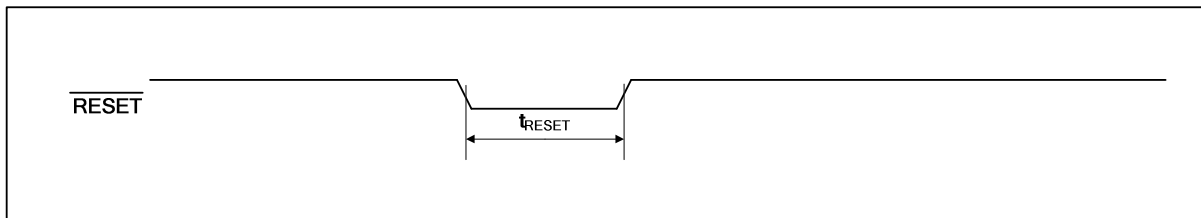

Figure 2 RESET Timing

Test Conditions

AVDD1, DVDD = 3.3V, AVDD2 = 9V, AGND1, AGND2, DGND = 0V, $T_A = +25^{\circ}C$

PARAMETER	SYMBOL	MIN	TYP	MAX	UNIT
RESET Timing Information					
RESET pulsewidth low	T_{RESET}	10			ns

Table 2 RESET Timing Requirements

DIGITAL AUDIO INTERFACE TIMING – SLAVE MODE

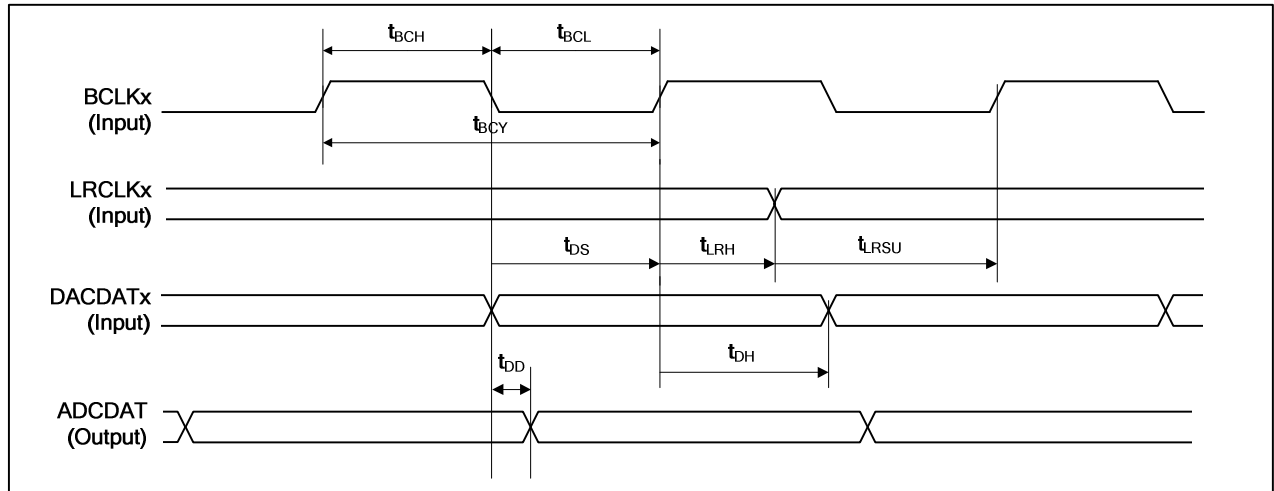

Figure 3 Slave Mode Digital Audio Data Timing

Test Conditions

AVDD1, DVDD = 3.3V, AVDD2 = 9V, AGND1, AGND2, DGND = 0V, T_A = +25°C, Slave Mode, fs = 48kHz, MCLK = 256fs, 24-bit data, unless otherwise stated.

PARAMETER	SYMBOL	MIN	TYP	MAX	UNIT
Audio Data Input Timing Information					
BCLK cycle time	t _{BCY}	80			ns
BCLK pulse width high	t _{BCH}	30			ns
BCLK pulse width low	t _{BCL}	30			ns
BCLK rise/fall times				5	ns
LRCLK set-up time to BCLK rising edge	t _{LRSU}	22			ns
LRCLK hold time from BCLK rising edge	t _{LRH}	25			ns
LRCLK rise/fall times				5	ns
DACDAT (input) hold time from LRCLK rising edge	t _{DH}	25			ns
ADCDAT (output) propagation delay from BCLK falling edge	t _{DD}	4		16	ns

Table 3 Slave Mode Audio Interface Timing

DIGITAL AUDIO INTERFACE TIMING – MASTER MODE

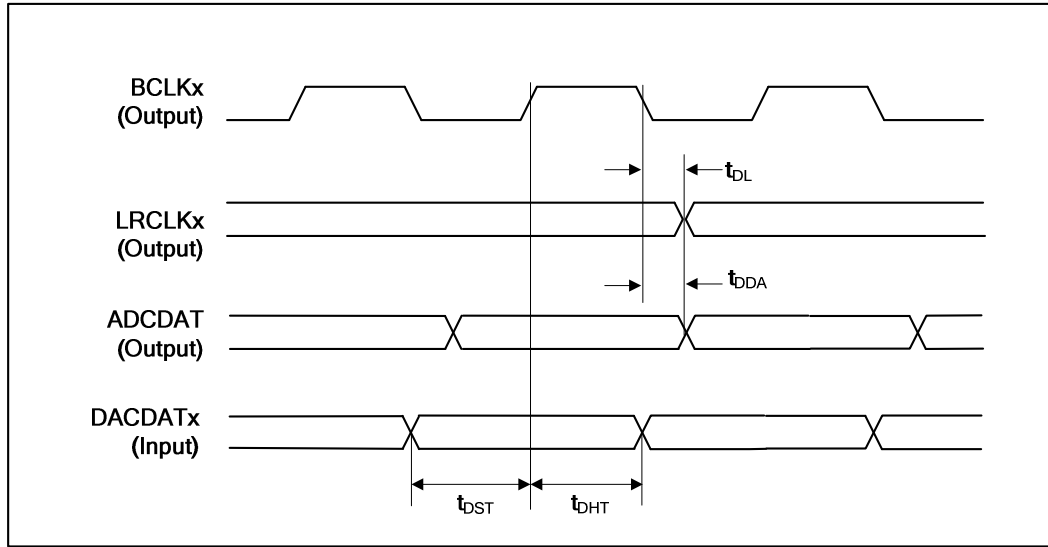

Figure 4 Master Mode Digital Audio Data Timing

Test Conditions

AVDD1, DVDD = 3.3V, AVDD2 = 9V, AGND1, AGND2, DGND = 0V, T_A = +25°C, Slave Mode, fs = 48kHz, MCLK = 256fs, 24-bit data, unless otherwise stated.

PARAMETER	SYMBOL	MIN	TYP	MAX	UNIT
Audio Data Input Timing Information					
LRCLK propagation delay from BCLK falling edge	t _{DL}	4		16	ns
ADCDAT (output) propagation delay from BCLK falling edge	t _{DDA}	4		16	ns
DACDAT (input) setup time to BCLK rising edge	t _{DST}	22			ns
DACDAT (input) hold time to BCLK rising edge	t _{DHT}	25			ns

Table 4 Master Mode Audio Interface Timing

CONTROL INTERFACE TIMING – 2-WIRE MODE

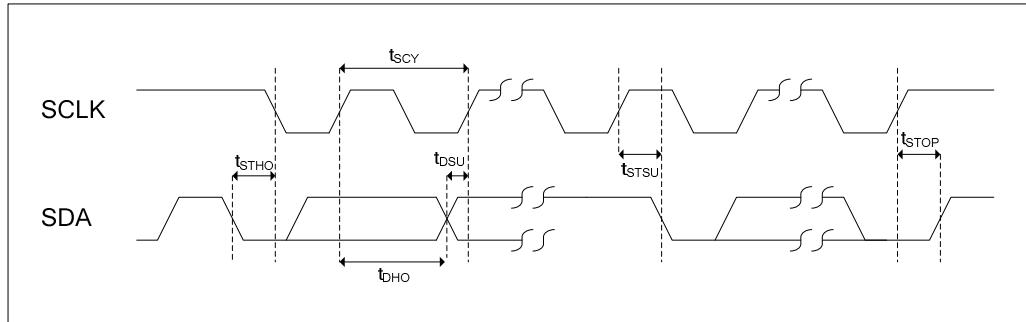

Figure 5 Control Interface Timing – 2-Wire Serial Control Mode

Test Conditions

AVDD1, DVDD = 3.3V, AVDD2 = 9V, AGND1, AGND2, DGND = 0V, $T_A = +25^\circ\text{C}$, Slave Mode, $f_s = 48\text{kHz}$, MCLK = 256fs, 24-bit data, unless otherwise stated.

PARAMETER	SYMBOL	MIN	TYP	MAX	UNIT
Program Register Input Information					
SCLK pulse cycle time	t_{SCY}	2500			ns
SCLK duty cycle		40/60		60/40	%
SCLK frequency				400	kHz
Hold Time (Start Condition)	t_{STHO}	600			ns
Setup Time (Start Condition)	t_{STSU}	600			ns
Data Setup Time	t_{DSU}	100			ns
SDA, SCLK Rise Time				300	ns
SDA, SCLK Fall Time				300	ns
Setup Time (Stop Condition)	t_{STOP}	600			ns
Data Hold Time	t_{DHO}			900	ns
Pulse width of spikes that will be suppressed	t_{ps}	2		8	ns

Table 5 Control Interface Timing – 2-Wire Serial Control Mode

CONTROL INTERFACE TIMING – 3-WIRE MODE

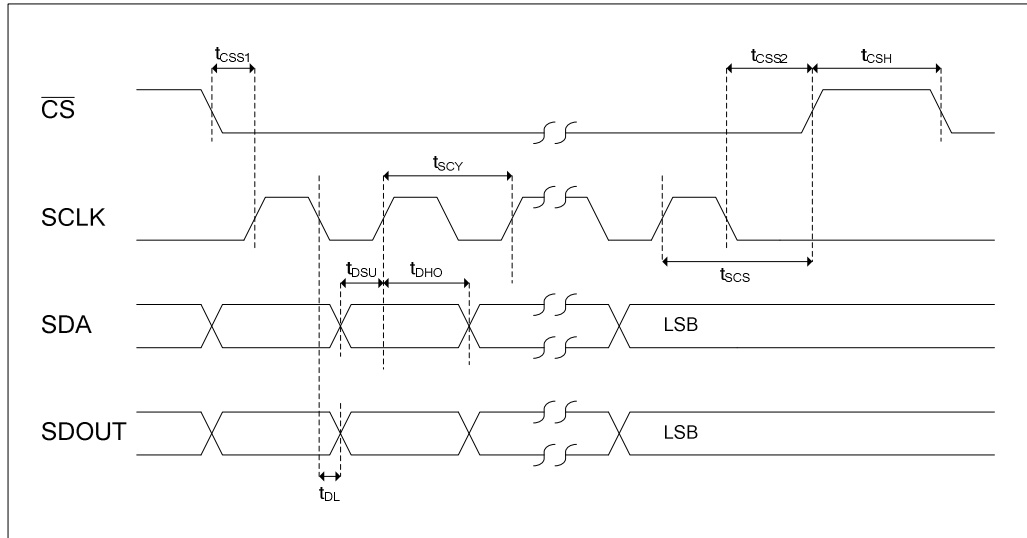

Figure 6 Control Interface Timing – 3-Wire Serial Control Mode

Test Conditions

AVDD1, DVDD = 3.3V, AVDD2 = 9V, AGND1, AGND2, DGND = 0V, $T_A = +25^\circ\text{C}$, Slave Mode, $f_s = 48\text{kHz}$, MCLK = 256fs, 24-bit data, unless otherwise stated.

PARAMETER	SYMBOL	MIN	TYP	MAX	UNIT
Program Register Input Information					
SCLK rising edge to CS rising edge	t_{scs}	80			ns
SCLK pulse cycle time	t_{scy}	160			ns
SCLK duty cycle		40/60		60/40	%
SDA to SCLK set-up time	t_{dsu}	20			ns
SDA hold time from SCLK rising edge	t_{dho}	40			ns
SDOUT propagation delay from SCLK falling edge	t_{dl}			5	ns
CS pulse width high	t_{csH}	40			ns
CS falling to SCLK rising	t_{css1}	40			ns
SCLK falling to CS rising	t_{css2}	40			ns
Pulse width of spikes that will be suppressed	t_{ps}	2		8	ns

Table 6 Control Interface Timing – 3-Wire Serial Control Mode

POWER ON RESET (POR)

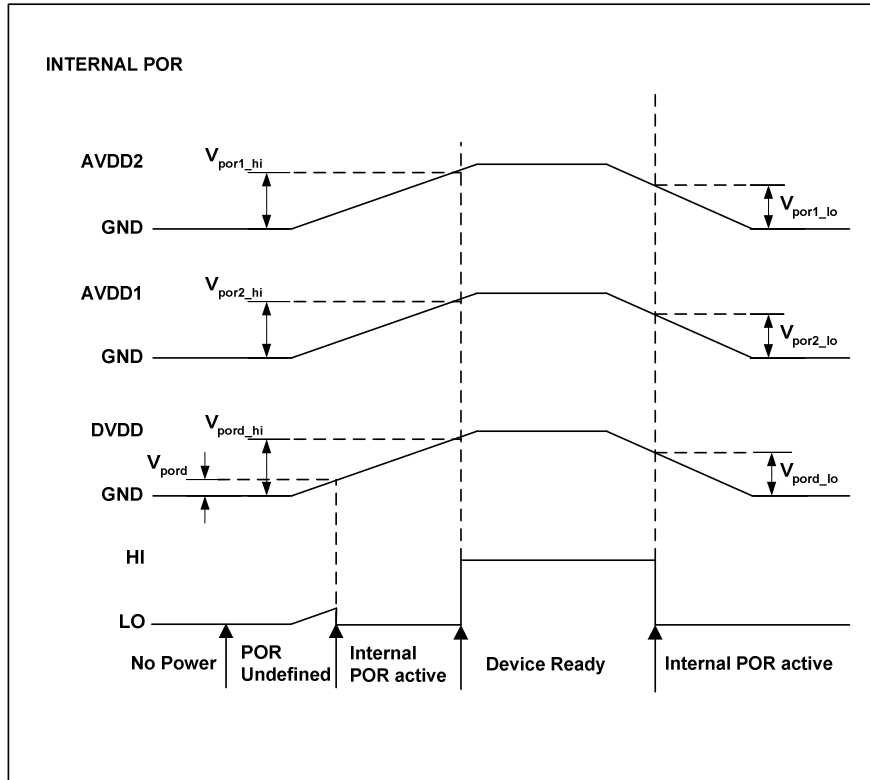

Figure 1 Power Supply Timing Requirements

Test Conditions

DVDD = 3.3V, AVDD1 = 3.3V, AVDD2 = 9V DGND = AGND1 = AGND2 = 0V, $T_A = +25^{\circ}\text{C}$, $T_{A_max} = +125^{\circ}\text{C}$, $T_{A_min} = -25^{\circ}\text{C}$
 $AVDD1_{max} = DVDD_{max} = 3.63\text{V}$, $AVDD1_{min} = DVDD_{min} = 2.97\text{V}$
 $AVDD2_{max} = 9.9\text{V}$, $AVDD2_{min} = 8.1\text{V}$

PARAMETER	SYMBOL	TEST CONDITIONS	MIN	TYP	MAX	UNIT
Power Supply Input Timing Information						
VDD level to POR defined (DVDD rising)	V_{por}	Measured from DGND	0.27	0.36	0.60	V
VDD level to POR rising edge (DVDD rising)	V_{por_hi}	Measured from DGND	1.34	1.88	2.32	V
VDD level to POR falling edge (DVDD falling)	V_{por_lo}	Measured from DGND	1.32	1.86	2.30	V
VDD level to POR rising edge (AVDD1 rising)	V_{por1_hi}	Measured from DGND	1.65	1.68	1.85	V
VDD level to POR falling edge (AVDD1 falling)	V_{por1_lo}	Measured from DGND	1.63	1.65	1.83	V
VDD level to POR rising edge (AVDD2 rising)	V_{por2_hi}	Measured from DGND	1.80	1.86	2.04	V
VDD level to POR falling edge (AVDD2 falling)	V_{por2_lo}	Measured from DGND	1.76	1.8	2.02	V

Table 7 Power on Reset

DEVICE DESCRIPTION

INTRODUCTION

The WM8595 is a high performance multi-channel audio CODEC with 2Vrms line level inputs and outputs and flexible digital input / output switching. The device comprises a 24-bit stereo ADC, two 24-bit stereo DACs with independent sampling rates and digital volume control, two stereo PGAs in the output path, a flexible digital audio interface multiplexer, a flexible analogue input multiplexer. Analogue inputs and outputs are all at 2Vrms line level, minimising external component count.

The DACs can operate from independent left/right clocks, bit clocks and master clocks with independent data inputs. Alternatively, the DACs can be synchronised to use the same clocks with independent data inputs.

The ADC uses a separate left/right clock, bit clock and master clock, allowing independent recording and playback in audio applications. The ADC audio interface can be configured to operate in either master or slave clocking mode. In master mode, left/right clocks and bit clocks are all outputs. In slave mode, left/right clocks and bit clocks are all inputs.

The ADC includes digital gain control, allowing signals to be gained and attenuated between +30dB and -97dB in 0.5dB steps.

The DACs include independent digital volume control, which is adjustable between +12dB and -100dB in 0.5dB steps. The DACs can be configured to output stereo audio data and a range of mono audio options.

The input analogue multiplexer accepts six stereo line level inputs at up to 2Vrms, and allows any stereo input to be routed to the input of the ADC.

The output PGAs have optional zero cross functionality, with gain adjustable between +6dB and -73.5dB in 0.5dB steps, and configurable soft ramp rate. Analogue audio is output at 2Vrms line level.

The digital audio interface multiplexer allows flexible routing of the digital signals internal to the device between the independent ADC, DAC1 and DAC2 audio interfaces from the digital audio ports. By integrating this functionality into the WM8595, the external component count and board space normally required to switch between various digital audio sources can be significantly reduced.

Control of the internal functionality of the device is by 2-wire or 3-wire serial control interface with readback. The interface may be asynchronous to the audio data interface as control data will be re-synchronised to the audio processing internally. In addition, control of mute, emergency shutdown and reset may also be achieved by pin control.

Operation using system clocks of 128fs, 192fs, 256fs, 384fs, 512fs, 768fs or 1152fs is provided. ADC and DACs may be clocked independently. Sampling rates from 32kHz to 192kHz are supported for both DACs provided the appropriate master clocks are input. Sampling rates from 32kHz to 96kHz are supported for the ADC provided the appropriate master clock is input.

The audio data interface supports right justified, left justified, and I2S interface formats along with a highly flexible DSP serial port interface format.

CONTROL INTERFACE

Control of the WM8595 is achieved by a 2-wire SM-bus-compliant or 3-wire SPI compliant serial interface with readback. Software interface mode is selected using the CIFMODE pin as shown in Table 8 below:

CIFMODE (PIN 44)	INTERFACE FORMAT
Low	2 wire
High	3 wire

Table 8 Control Interface Mode Selection

2-WIRE (SM-BUS COMPATIBLE) SERIAL CONTROL INTERFACE MODE

Many devices can be controlled by the same bus, and each device has a unique 7-bit address.

REGISTER WRITE

The controller indicates the start of data transfer with a high to low transition on SDA while SCLK remains high. This indicates that a device address and data will follow. All devices on the 2-wire bus respond to the start condition and shift in the next eight bits on SDA (7-bit address and read/write bit, MSB first). If the device address received matches the address of the WM8595, the WM8595 responds by pulling SDA low on the next clock pulse (ACK). If the address is not recognised, the WM8595 returns to the idle condition and waits for a new start condition with valid address.

When the WM8595 has acknowledged a correct address, the controller sends the first byte of control data (B23 to B16, i.e. the WM8595 register address). The WM8595 then acknowledges the first data byte by pulling SDA low for one SCLK pulse. The controller then sends a second byte of control data (B15 to B8, i.e. the first 8 bits of register data), and the WM8595 acknowledges again by pulling SDA low for one SCLK pulse. Finally, the controller sends a third byte of control data (B7 to B0, i.e. the final 8 bits of register data), and the WM8595 acknowledges again by pulling SDA low for one SCLK pulse.

The transfer of data is complete when there is a low to high transition on SDA while SCLK is high. After receiving a complete address and data sequence the WM8595 returns to the idle state and waits for another start condition. If a start or stop condition is detected out of sequence at any point during data transfer (i.e. SDA changes while SCLK is high), the WM8595 reverts to the idle condition.

The WM8595 device 2-wire write address is 34h (0110100) or 36h (0110110), selectable by control of CS.

CS (PIN 46)	2-WIRE BUS ADDRESS (B[7:1])
0	34h (011010)
1	36h (011011)

Table 9 2-Wire Control Interface Bus Address Selection

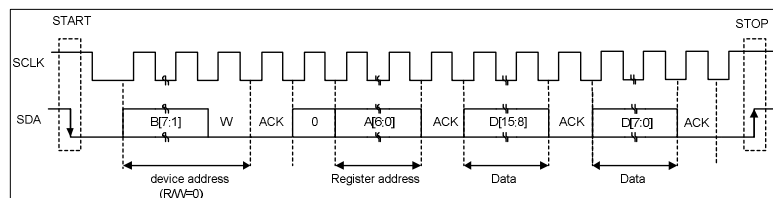

Figure 7 2-Wire Write Protocol

AUTO-INCREMENT REGISTER WRITE

It is possible to write to multiple consecutive registers using the auto-increment feature. When AUTO_INC is set, the register write protocol follows the method shown in Figure 8

. As with normal register writes, the controller indicates the start of data transfer with a high to low transition on SDA while SCLK remains high, and all devices on the bus receive the device address.

When the WM8595 has acknowledged a correct address, the controller sends the first byte of control data (A6 to A0, i.e. the WM8595 initial register address). The WM8595 then acknowledges the first control data byte by pulling SDA low for one SCLK pulse. The controller then sends a byte of register data. The WM8595 acknowledges the first byte of register data, auto-increments the register address to be written to, and waits for the next byte of register data. Subsequent bytes of register data can be written to consecutive registers of the WM8595 without setting up the device and register address.

The transfer of data is complete when there is a low to high transition on SDA while SCLK is high.

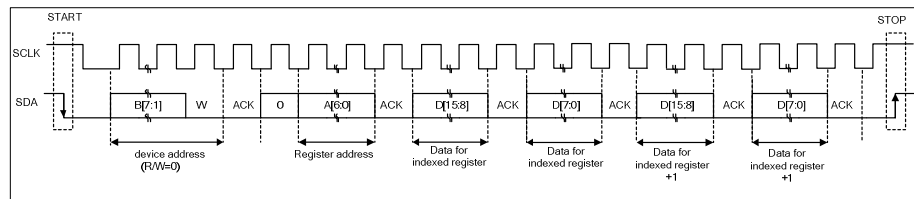

Figure 8 2-Wire Auto-Increment Register Write

REGISTER READBACK

The WM8595 allows readback of all registers with data output on the bidirectional SDA pin. The protocol is similar to that used to write to the device. The controller will issue the device address followed by a write bit, and the register index will then be passed to the WM8595.

At this point the controller will issue a repeated start condition and resend the device address along with a read bit. The WM8595 will acknowledge this and the WM8595 will become a slave transmitter.

The WM8595 will place the data from the indexed register onto SDA MSB first. When the controller receives the first byte of data, it acknowledges it. When the controller receives the second and final byte of data it will not acknowledge receipt of the data indicating that it will resume master transmitter control of SDA. The controller will then issue a stop command completing the read cycle.

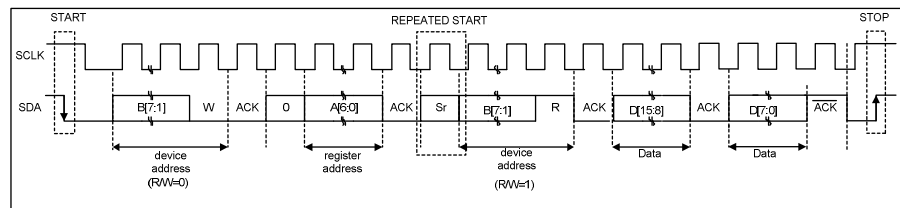

Figure 9 2-wire Read Protocol

AUTO-INCREMENT REGISTER READBACK

It is possible to read from multiple consecutive registers in continuous readback mode. Continuous readback mode is selected by setting AUTO_INC. In continuous readback mode, the WM8595 will return the indexed register first, followed by consecutive registers in increasing index order until the controller issues a stop sequence.

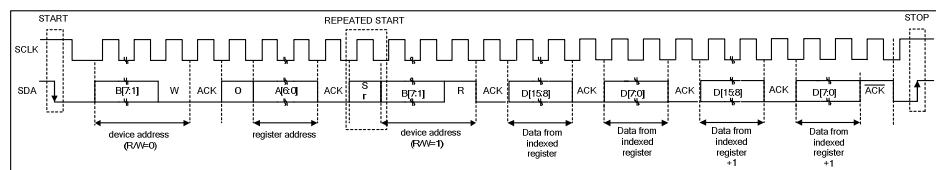

Figure 10 2-Wire Auto-Increment Register Readback

3-WIRE (SPI COMPATIBLE) SERIAL CONTROL INTERFACE MODE

REGISTER WRITE

SDA is used for the program data, SCLK is used to clock in the program data and CS is use to latch in the program data. SDA is sampled on the rising edge of SCLK. The 3-wire interface write protocol is shown in Figure 11.

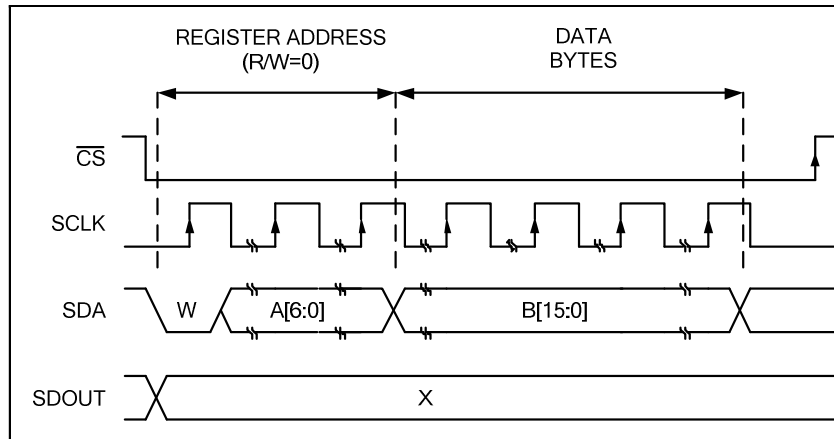

Figure 11 3-Wire Serial Interface Write Protocol

- W indicates write operation.
- A[6:0] is the register index.
- B[15:0] is the data to be written to the register indexed.
- CS is edge sensitive – the data is latched on the rising edge of /CS.

REGISTER READ-BACK

The read-only status registers can be read back via the SDOUT pin. Read Back is enabled when the R/W bit is high. The data can then be read by writing to the appropriate register address, to which the device will respond with data.

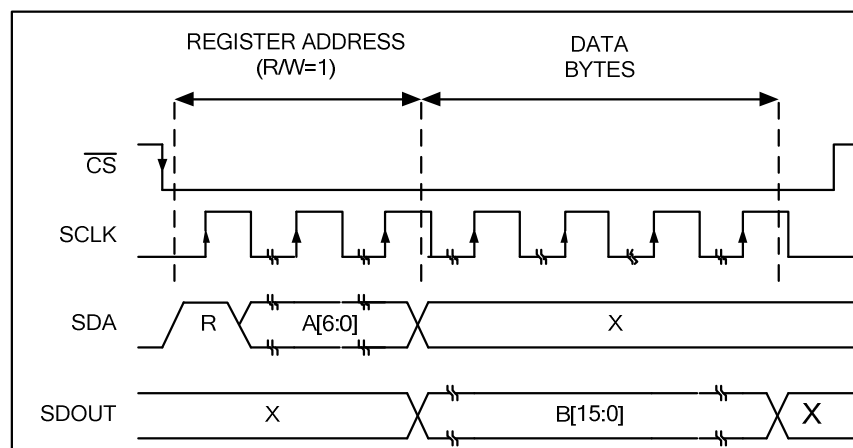

Figure 12 3-Wire Serial Interface Readback Protocol

REGISTER RESET

Any write to register R0 (00h) will reset the WM8595. All register bits are reset to their default values.

DEVICE ID AND REVISION

Reading from register R0 returns the device ID. Reading from register R1 returns the device revision number.

REGISTER ADDRESS	BIT	LABEL	DEFAULT	DESCRIPTION
R0 DEVICE_ID 00h	15:0	DEVICE_ID [15:0]	10000101 10010101	Device ID A read of this register will return the device ID, 0x8595.
R1 REVISION 01h	7:0	REVNUM [7:0]	N/A	Device Revision A read of this register will return the device revision number. This number is sequentially incremented if the device design is updated.

Table 10 Device ID and Revision Number

DIGITAL AUDIO DATA FORMATS

The WM8595 supports a range of common audio interface formats:

- I²S
- Left Justified (LJ)
- Right Justified (RJ)
- DSP Mode A
- DSP Mode B

All formats send the MSB first and support word lengths of 16, 20, 24 and 32 bits, with the exception of 32 bit RJ mode, which is not supported.

Audio data for each stereo channel is time multiplexed with the interface's left/right clock indicating whether the left or right channel is present. The left/right clock is also used as a timing reference to indicate the beginning or end of the data words.

In LJ, RJ and I²S modes, the minimum number of bit clock periods per left/right clock period is two times the selected word length. The left/right clock must be high for a minimum of bit clock periods equivalent to the word length, and low for the same period. For example, for a word length of 24 bits, the left/right clock must be high for a minimum of 24 bit clock periods and low for a minimum of 24 bit clock periods. Any mark to space ratio is acceptable for the left/right clock provided these requirements are met.

In DSP modes A and B, left and right channels must be time multiplexed and input on DACDAT. LRCLK is used as a frame synchronisation signal to identify the MSB of the first input word. The minimum number of bit clock periods per left/right clock period is two times the selected word length. Any mark to space ratio is acceptable for the left/right clock provided the rising edge is correctly positioned.

I²S MODE

In I²S mode, the MSB of input data is sampled on the second rising edge of bit clock following a left/right clock transition. The MSB of output data changes on the first falling edge of bit clock following a left/right clock transition, and may be sampled on the next rising edge of bit clock. Left/right clocks are low during the left channel audio data samples and high during the right channel audio data samples.

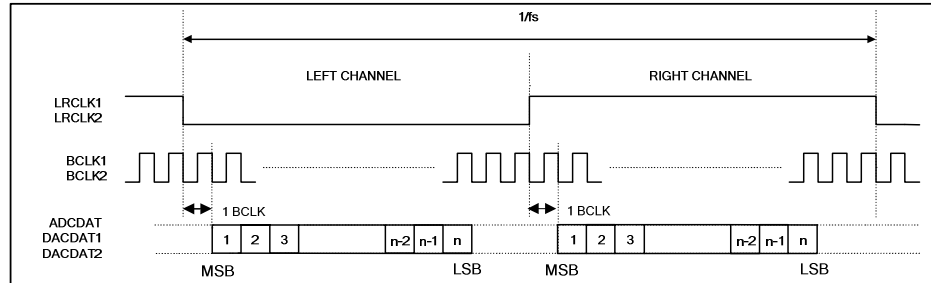

Figure 13 I2S Mode Timing

LEFT JUSTIFIED (LJ) MODE

In LJ mode, the MSB of the input data is sampled by the WM8595 on the first rising edge of bit clock following a left/right clock transition. The MSB of output data changes on the same falling edge of bit clock as left/right clock and may be sampled on the next rising edge of bit clock. Left/right clock is high during the left channel audio data samples and low during the right channel audio data samples.

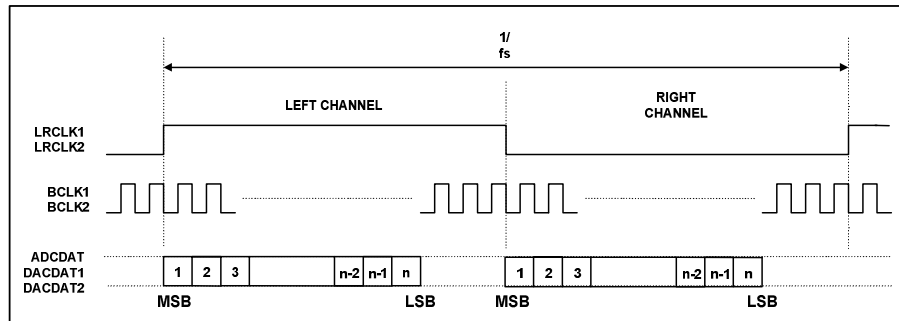

Figure 14 LJ Mode Timing

RIGHT JUSTIFIED (RJ) MODE

In RJ mode the LSB of input data is sampled on the rising edge of bit clock preceding a left/right clock transition. The LSB of output data changes on the falling edge of bit clock preceding a left/right clock transition, and may be sampled on the next rising edge of bit clock. Left/right clock is high during the left channel audio data samples and low during the right channel audio data samples.

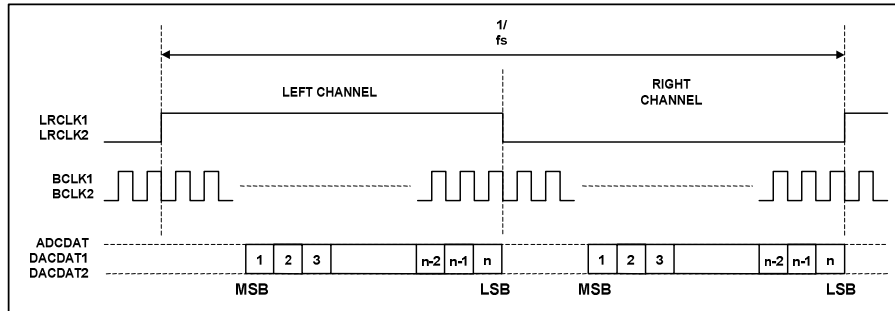

Figure 15 RJ Mode Timing

DSP MODE A

In DSP Mode A, the MSB of channel 1 left data input is sampled on the second rising edge of bit clock following a left/right clock rising edge. Channel 1 right data then follows. The MSB of output data changes on the first falling edge of bit clock following a left/right clock transition and may be sampled on the rising edge of bit clock. The right channel data is contiguous with the left channel data.

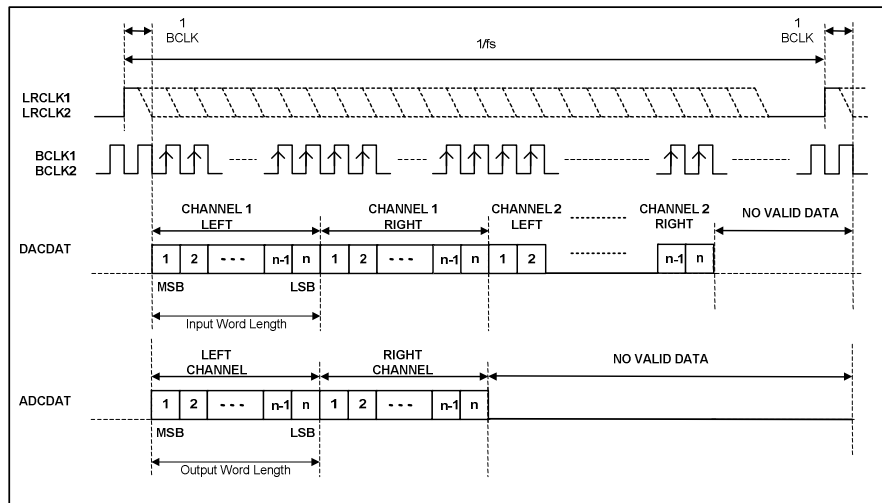

Figure 16 DSP Mode A Timing

DSP MODE B

In DSP Mode B, the MSB of channel 1 left data input is sampled on the first bit clock rising edge following a left/right clock rising edge. Channel 1 right data then follows. The MSB of output data changes on the same falling edge of BCLK as the low to high left/right clock transition and may be sampled on the rising edge of bit clock. The right channel data is contiguous with the left channel data.

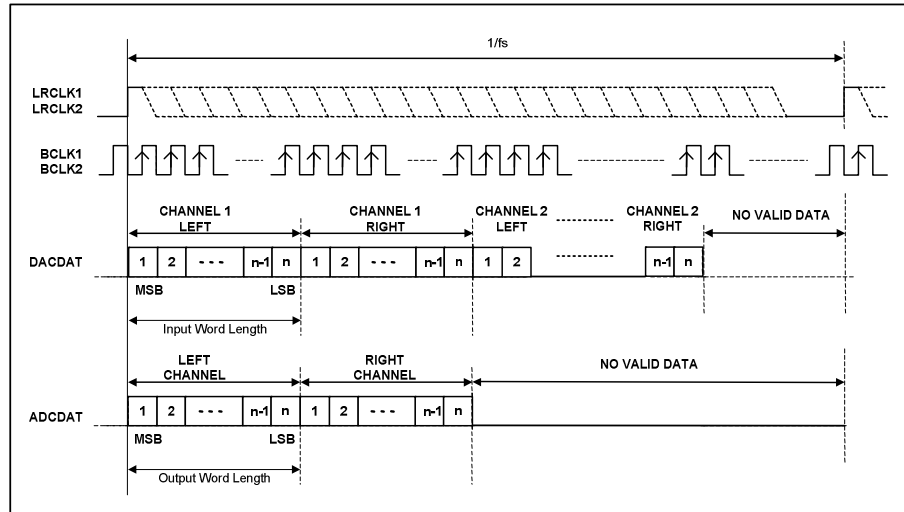

Figure 17 DSP Mode B Timing

DIGITAL AUDIO INTERFACE CONTROL

The control of the audio interface formats is achieved by register write. Dynamically changing the audio data format may cause erroneous operation and is not recommended.

Interface timing is such that the input data and left/right clock are sampled on the rising edge of the interface bit clock. Output data changes on the falling edge of the interface bit clock. By setting the appropriate bit clock and left/right clock polarity bits, the WM8595 ADC and DACs can sample data on the opposite clock edges.

The control of audio interface formats and clock polarities is summarised in Table 11.

REGISTER ADDRESS	BIT	LABEL	DEFAULT	DESCRIPTION
R2 DAC1_CTRL1 02h	1:0	DAC1_ FMT[1:0]	10	DAC1 Audio Interface Format 00 = Right Justified 01 = Left Justified 10 = I ² S 11 = DSP
	3:2	DAC1_ WL[1:0]	10	DAC1 Audio Interface Word Length 00 = 16-bit 01 = 20-bit 10 = 24-bit 11 = 32-bit (not available in Right Justified mode)
	4	DAC1_BCP	0	DAC1 BCLK Polarity 0 = DACBCLK not inverted - data latched on rising edge of BCLK 1 = DACBCLK inverted - data latched on falling edge of BCLK

REGISTER ADDRESS	BIT	LABEL	DEFAULT	DESCRIPTION
	5	DAC1_LRP	0	DAC1 LRCLK Polarity 0 = DACLRCLK not inverted 1 = DACLRCLK inverted
R7 DAC2_CTRL1 07h	1:0	DAC2_ FMT[1:0]	10	DAC2 Audio Interface Format 00 = Right Justified 01 = Left Justified 10 = I ² S 11 = DSP
	3:2	DAC2_ WL[1:0]	10	DAC2 Audio Interface Word Length 00 = 16-bit 01 = 20-bit 10 = 24-bit 11 = 32-bit (not available in Right Justified mode)
	4	DAC2_BCP	0	DAC2 BCLK Polarity 0 = DACBCLK not inverted - data latched on rising edge of BCLK 1 = DACBCLK inverted - data latched on falling edge of BCLK
	5	DAC2_LRP	0	DAC2 LRCLK Polarity 0 = DACLRCLK not inverted 1 = DACLRCLK inverted
R13 ADC_CTRL1 0Dh	1:0	ADC_ FMT[1:0]	10	ADC Audio Interface Format 00 = Right Justified 01 = Left Justified 10 = I ² S 11 = DSP
	3:2	ADC_ WL[1:0]	10	ADC Audio Interface Word Length 00 = 16-bit 01 = 20-bit 10 = 24-bit 11 = 32-bit (not available in Right Justified mode)
	4	ADC_BCP	0	ADC BCLK Polarity 0 = ADCBCLK not inverted - data latched on rising edge of BCLK 1 = ADCBCLK inverted - data latched on falling edge of BCLK
	5	ADC_LRP	0	ADC LRCLK Polarity 0 = ADCLRCLK not inverted 1 = ADCLRCLK inverted

Table 11 Audio Interface Control

DIGITAL AUDIO INTERFACE

Digital audio data is transferred to and from the WM8595 via the digital audio interface. The DACs have independent data inputs and master clocks, bit clocks and left/right frame clocks, and operate in both master or slave mode. The ADC has independent master clock, bit clock and left/right frame clock in addition to its data output, and can operate in both master and slave modes.

MASTER MODE

The ADC audio interface requires both a left/right frame clock (ADCLRCLK) and a bit clock (ADCBCLK). These can be supplied externally (slave mode) or they can be generated internally (master mode). Selection of master and slave mode is achieved by setting ADC_MSTR in ADC Control Register 3.

The frequency of ADCLRCLK in master mode is dependent upon the ADC master clock frequency and the ADC_SR[2:0] bits.

The frequency of ADCBCLK in master mode can be selected by ADC_BCLKDIV[1:0].

Both DAC1 and DAC2 operate in slave mode only.

REGISTER ADDRESS	BIT	LABEL	DEFAULT	DESCRIPTION
R14 ADC_CTRL2 0Eh	2:0	ADC_SR[2:0]	000	ADC MCLK:LRCLK Ratio 000 = Auto detect 001 = 128fs 010 = 192fs 011 = 256fs 100 = 384fs 101 = 512fs 110 = 768fs 111 = Reserved
	5:3	ADC_BCLK DIV[2:0]	000	ADC BCLK Rate 000 = MCLK / 4 001 = MCLK / 8 010 = 32fs 011 = 64fs 100 = 128fs All other values of ADC_BCLKDIV[2:0] are reserved
R15 ADC_CTRL3 0Fh	0	ADC_MSTR	0	ADC Master Mode Select 0 = Slave mode, ADCBCLK and ADCLRCLK are inputs to WM8595 1 = Master mode, ADCBCLK and ADCLRCLK are outputs from WM8595

Table 12 ADC Master Mode Control

SLAVE MODE

In slave mode, the master clock to left/right clock ratio for the ADC, DAC1 and DAC2 can be auto-detected or set manually by register write.

REGISTER ADDRESS	BIT	LABEL	DEFAULT	DESCRIPTION
R3 DAC1_CTRL2 03h	2:0	DAC1_ SR[2:0]	000	DAC MCLK:LRCLK Ratio 000 = Auto detect 001 = 128fs
R8 DAC2_CTRL2 08h	2:0	DAC2_ SR[2:0]	000	010 = 192fs 011 = 256fs 100 = 384fs 101 = 512fs 110 = 768fs 111 = 1152fs
R14 ADC_CTRL2 0Eh	2:0	ADC_ SR[2:0]	000	ADC MCLK:LRCLK Ratio 000 = Auto detect 001 = reserved 010 = reserved 011 = 256fs 100 = 384fs 101 = 512fs 110 = 768fs 111 = Reserved

Table 13 Slave Mode MCLK to LRCLK Ratio Control

DIGITAL AUDIO DATA SAMPLING RATES

In a typical digital audio system there is one central clock source producing a reference clock to which all audio data processing is synchronised. This clock is often referred to as the audio system's master clock. The WM8595 uses independent master clocks for ADC and DACs. The external master clocks can be applied directly to the ADCMCLK, DACMCLK1 and DACMCLK2 input pins. In a system where there are a number of possible sources for the reference clock, it is recommended that the clock source with the lowest jitter be used for the master clock to optimise the performance of the WM8595.

In slave clocking mode the WM8595 has a master detection circuit that automatically determines the relationship between the master clock frequency (ADCMCLK, DACMCLK1, DACMCLK2) and the sampling rate (ADCLRCLK, DACLRCLK1, DACLRCLK2), to within +/- 32 system clock periods. The master clocks must be synchronised with the left/right clocks, although the device is tolerant of phase variations or jitter on the master clocks.

The ADC supports master clock to sampling clock ratios of 256fs to 768fs and sampling rates of 32kHz to 96kHz, provided the internal signal processing of the ADC is programmed to operate at the correct rate. The DACs support master clock to sampling clock ratios of 128fs to 1152fs and sampling rates of 32kHz to 192kHz, provided the internal signal processing of the DACs is programmed to operate at the correct rate.

Table 14 shows typical master clock frequencies and sampling rates supported by the WM8595 ADC. Table 15 shows typical master clock frequencies and sampling rates supported by the WM8595 DACs.

Sampling Rate (ADCLRCLK)	MASTER CLOCK FREQUENCY (MHZ)			
	256fs	384fs	512fs	768fs
32kHz	8.192	12.288	16.384	24.576
44.1kHz	11.2896	16.9344	22.5792	33.8688
48kHz	12.288	18.432	24.576	36.864
88.2kHz	22.5792	33.8688	Unavailable	Unavailable
96kHz	24.576	Unavailable	Unavailable	Unavailable

Table 14 ADC Master Clock Frequency Versus Sampling Rate

Sampling Rate (DACLRCLK1 DACLRCLK2)	MASTER CLOCK FREQUENCY (MHZ)						
	128fs	192fs	256fs	384fs	512fs	768fs	1152fs
32kHz	Unavailable	Unavailable	8.192	12.288	16.384	24.576	36.864
44.1kHz	Unavailable	8.4672	11.2896	16.9344	22.5792	33.8688	Unavailable
48kHz	Unavailable	9.216	12.288	18.432	24.576	36.864	Unavailable
88.2kHz	11.2896	16.9344	22.5792	33.8688	Unavailable	Unavailable	Unavailable
96kHz	12.288	18.432	24.576	36.864	Unavailable	Unavailable	Unavailable
176.4kHz	22.5792	33.8688	Unavailable	Unavailable	Unavailable	Unavailable	Unavailable
192kHz	24.576	36.864	Unavailable	Unavailable	Unavailable	Unavailable	Unavailable

Table 15 DAC Master Clock Frequency Versus Sampling Rate

DAC FEATURES

The WM8595 includes two 24-bit DACs with independent clocks and independent data inputs. The DACs include digital volume control with zero cross and soft mute, de-emphasis support, and the capability to select the output channels to be stereo or a range of mono options. The DACs are enabled by writing to DAC1_EN and DAC2_EN.

REGISTER ADDRESS	BIT	LABEL	DEFAULT	DESCRIPTION
R2 DAC1_CTRL1 02h	8	DAC1_EN	0	DAC1 Enable 0 = DAC disabled 1 = DAC enabled
R7 DAC2_CTRL1 07h	8	DAC2_EN	0	DAC2 Enable 0 = DAC2 disabled 1 = DAC2 enabled

Table 16 DAC Enable Control

DIGITAL VOLUME CONTROL

The WM8595 DACs include independent digital volume control, allowing the digital gain to be adjusted between -100dB and +12dB in 0.5dB steps. All four DAC channels can be controlled independently. Alternatively, global update bits allow the user to write all volume changes before the volume is updated.

Volume control includes optional zero cross functionality. When zero cross is enabled, volume changes are not applied until the output level crosses VMID. Zero cross helps to prevent pop and click noise when changing volume settings.

REGISTER ADDRESS	BIT	LABEL	DEFAULT	DESCRIPTION
R5 DAC1L_VOL 05h	7:0	DAC1L _VOL[7:0]	11001000	DAC Digital Volume 0000 0000 = -100dB 0000 0001 = -99.5dB 0000 0010 = -99dB ...0.5dB steps 1100 1000 = 0dB ...0.5dB steps 1101 1111 = +11.5dB 111X XXXX = +12dB
R6 DAC1R_VOL 06h	7:0	DAC1R _VOL[7:0]		
R10 DAC2L_VOL 0Ah	7:0	DAC2L _VOL[7:0]		
R11 DAC2R_VOL 0Bh	7:0	DAC2R _VOL[7:0]		
R5 DAC1L_VOL 05h	8	DAC1L_VU	0	DAC Digital Volume Update 0 = Latch DAC volume setting into Register Map but do not update volume 1 = Latch DAC volume setting into Register Map and update left and right channels simultaneously
R6 DAC1R_VOL 06h	8	DAC1R_VU		
R10 DAC2L_VOL 0Ah	8	DAC2L_VU		
R11 DAC2R_VOL 0Bh	8	DAC2R_VU		

REGISTER ADDRESS	BIT	LABEL	DEFAULT	DESCRIPTION
R2 DAC1_CTRL1 02h	7	DAC1 _ZCEN	1	DAC Digital Volume Control Zero Cross Enable 0 = Do not use zero cross 1 = Use zero cross
R7 DAC2_CTRL1 07h	7	DAC2 _ZCEN		

Table 17 DAC Digital Volume Control

SOFTMUTE

A soft mute can be applied to DAC1 and DAC2 independently.

REGISTER ADDRESS	BIT	LABEL	DEFAULT	DESCRIPTION
R2 DAC1_CTRL1 02h	9	DAC1_ MUTE	0	DAC Softmute 0 = Normal operation 1 = Softmute applied
R7 DAC2_CTRL1 07h	9	DAC2_ MUTE	0	

Table 18 DAC Softmute Control

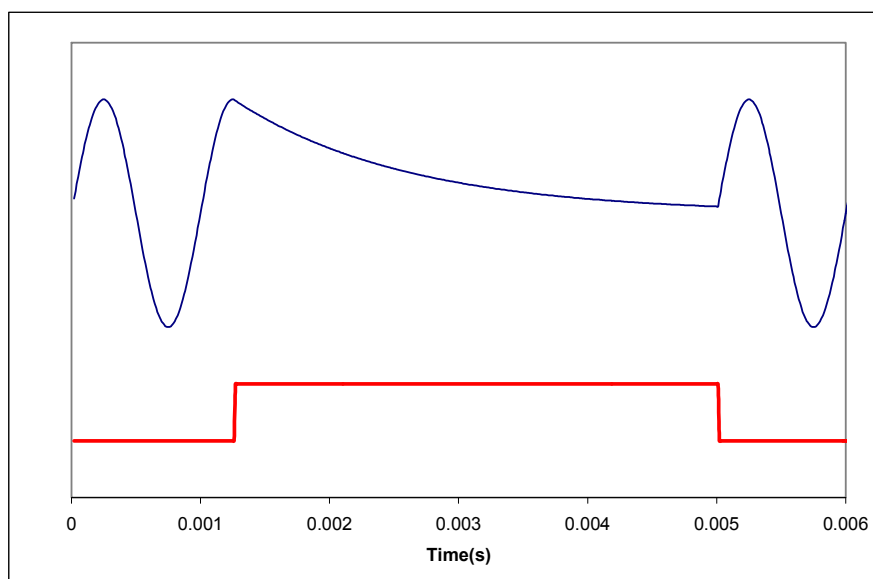

Figure 18 Application and Release of DAC Soft Mute

Figure 18 shows the applications and release of DAC soft mute whilst a full amplitude sinusoid is being played at 48kHz sampling rate. When DACx_MUTE (lower trace) is asserted, the output (upper trace) of the appropriate DAC will decay exponentially from the DC level of the last input sample towards VMID2C with a time constant of approximately 64 input samples. When DACx_MUTE is de-asserted, the output will restart immediately from the current input sample.

DIGITAL MONOMIX CONTROL

Each DAC can be independently set to output a range of mono and stereo options. Each DAC output channel can output left channel data, right channel data or a mix of left and right channel data.

REGISTER ADDRESS	BIT	LABEL	DEFAULT	DESCRIPTION
R2 DAC1_CTRL1 02h	11:10	DAC1_OP_MUX[1:0]	00	DAC1 Digital Monomix 00 = Stereo (Normal Operation) 01 = Mono (Left data to DAC1R) 10 = Mono (Right data to DAC1L) 11 = Digital Monomix, (L+R)/2
R7 DAC2_CTRL1 07h	11:10	DAC2_OP_MUX[1:0]	00	DAC2 Digital Monomix 00 = Stereo (Normal Operation) 01 = Mono (Left data to DAC2R) 10 = Mono (Right data to DAC2L) 11 = Digital Monomix, (L+R)/2

Table 19 Digital Monomix Control

DE-EMPHASIS

A digital de-emphasis filter may be applied to the DAC outputs when the sampling frequency is 44.1kHz. The de-emphasis filter for each DAC can be applied independently. The de-emphasis filter responses and error can be seen in Figure 60 De-Emphasis Frequency Response (32kHz) and Figure 61 De-Emphasis Error (32kHz).

Note: De-emphasis is not available when MCLK=192fs.

REGISTER ADDRESS	BIT	LABEL	DEFAULT	DESCRIPTION
R2 DAC1_CTRL1 02h	6	DAC1_DEEMPH	0	DAC1 De-emphasis 0 = No de-emphasis 1 = Apply 44.1kHz de-emphasis
R7 DAC2_CTRL1 07h	6	DAC2_DEEMPH	0	DAC2 De-emphasis 0 = No de-emphasis 1 = Apply 44.1kHz de-emphasis

Table 20 De-emphasis Control

SIMULTANEOUS DAC1 AND DAC2 CONTROL

If the same settings are required to both DAC1 and DAC2, it is possible to have the register settings of DAC2 copy the register settings made to DAC1. To use this feature, the user must ensure that DAC2_COPY_DAC1 is set before writes are made to DAC1. Any writes then made to R2-6 are automatically made to R7-11.

Example (When DAC2_COPY_DAC1=1):

REGISTER WRITE	ACTUAL REGISTER SETTING
R2 = 0x0001	R2 = 0x0001 & R7 = 0x0001
R3 = 0x0023	R3 = 0x0023 & R8 = 0x0023
R4 = 0x0045	R4 = 0x0045 & R9 = 0x0045
R5 = 0x0067	R5 = 0x0067 & R10 = 0x0067
R6 = 0x0089	R6 = 0x0089 & R11 = 0x0089

REGISTER ADDRESS	BIT	LABEL	DEFAULT	DESCRIPTION
R12 ENABLE 0Bh	1	DAC2_COPY_DAC1	0	DAC2 Configuration Control 0 = DAC2 settings independent of DAC1 1 = DAC2 settings are the same as DAC1

Table 21 DAC2 Configuration Control

ANALOGUE OUTPUT VOLUME CONTROL

ANALOGUE VOLUME CONTROL

Each analogue output includes analogue volume control. Volume changes can be applied to each output immediately as they are written. Alternatively, all volume changes can be written, and then all volume changes can be applied simultaneously using the volume update feature.

Volume control includes optional zero cross functionality. When zero cross is enabled, volume changes are not applied until the output level crosses the DC level of the analogue channel (VMID). Zero cross helps to prevent pop and click noise when changing volume settings.

The zero cross function includes a timeout which forces volume changes if a zero cross event does not occur. The timeout period is a maximum of 278ms.

REGISTER ADDRESS	BIT	LABEL	DEFAULT	DESCRIPTION
R19 PGA1L_VOL 13h	7:0	PGA1L_VOL[7:0]	00001100	PGA Volume 0000 0000 = +6dB 0000 0001 = +5.5dB ...0.5dB steps 00001100 = 0dB ... 1001 1110 = -73.5dB 1001 1111 = PGA Mute
R20 PGA1R_VOL 14h	7:0	PGA1R_VOL[7:0]		
R21 PGA2L_VOL 15h	7:0	PGA2L_VOL[7:0]		
R22 PGA2R_VOL 16h	7:0	PGA2R_VOL[7:0]		
R19 PGA1L_VOL 13h	8	PGA1L_VU	0	PGA Volume Update 0 = Latch corresponding volume setting into Register Map but do not update volume 1 = Latch corresponding volume setting into Register Map and update all channels simultaneously
R20 PGA1R_VOL 14h	8	PGA1R_VU		
R21 PGA2L_VOL 15h	8	PGA2L_VU		
R22 PGA2R_VOL 16h	8	PGA2R_VU		
R25 PGA_CTRL1 19h	2	PGA1L_ZC	0	PGA Gain Zero Cross Enable 0 = PGA gain updates occur immediately 1 = PGA gain updates occur on zero cross
	3	PGA1R_ZC		
	4	PGA2L_ZC		
	5	PGA2R_ZC		

Table 22 Analogue Volume Control

VOLUME RAMP

Analogue volume can be adjusted by step change or by soft ramp. The ramp rate is dependent upon the sampling rate. The sampling rate upon which the volume ramp rate is based can be selected between the DAC sampling rate or the ADC sampling rate in either slave mode or master mode. The ramp rates for common audio sample rates are shown in Table 23:

SAMPLE RATE FOR PGA (kHz)	DIVIDE BY	PGA RAMP RATE (ms/dB)
32	8	0.50
44.1	8	0.36
48	8	0.33
88.2	16	0.36
96	16	0.33
176.4	32	0.36
192	32	0.33

Table 23 Analogue Volume Ramp Rate

For example, when using a sample rate of 48kHz, the time taken for a volume change from an initial setting of 0dB to -20dB is calculated as follows:

$$\text{Volume Change (dB)} \times \text{PGA Ramp Rate (ms/dB)} = 20 \times 0.33 = 6.6\text{ms}$$

When changing from one PGA ramp clock source to another, it is recommended that PGA_SAFE_SW is set to 0. This forces the clock switch over to occur at a point where all relevant clock signals are zero, ensuring glitch-free operation. This process can take up to 32 left/right clock cycles.

If a faster change in PGA ramp rate clock source is required, PGA_FORCE can be set to 1. This forces the change in clock source to occur immediately regardless of the state of the relevant clock signals internally. Glitch-free operation is not guaranteed under these conditions. PGA_FORCE must be set back to 0 to initialise the timing circuits with the new clock.

If the volume ramp function is not required when increasing or decreasing volume, this block can be bypassed by setting ATTACK_BYPASS or DECAY_BYPASS to 1. Figure 19 shows the effect of these register settings:

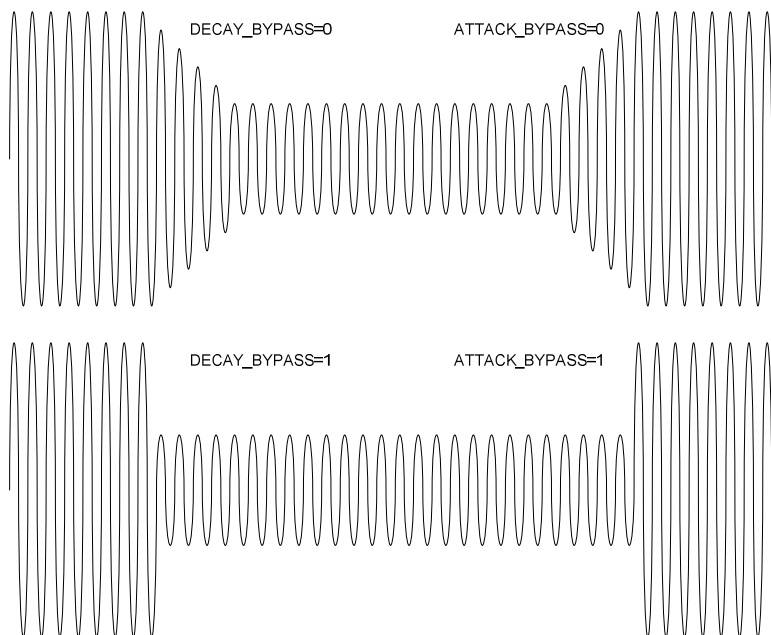

Figure 19 ATTACK_BYPASS and DECAY_BYPASS Functionality

Note: When ATTACK_BYPASS=1 or DECAY_BYPASS=1, it is recommended that the zero cross function for the PGA is used to eliminate click noise when changing volume settings.

REGISTER ADDRESS	BIT	LABEL	DEFAULT	DESCRIPTION
R25 PGA_CTRL1 19h	0	DECAY_ BYPASS	0	PGA Gain Decay Mode 0 = PGA gain will ramp down 1 = PGA gain will step down
	1	ATTACK_ BYPASS	0	PGA Gain Attack Mode 0 = PGA gain will ramp up 1 = PGA gain will step up
R27 ADD_CTRL1 1Bh	6:4	PGA_ SR[2:0]	001	Sample Rate for PGA 000 = 32kHz 001 = 44.1kHz 010 = 48kHz 011 = 88.2kHz 100 = 96kHz 101 = 176.4kHz 11X = 192kHz See Table 23 for further information on PGA sample rate versus volume ramp rate.
R36 PGA_CTRL3 24h	3:1	PGA_ SEL[2:0]	000	PGA Ramp Control Clock Source 000 = LRCLK1 001 = LRCLK2 010 to 110 = Reserved 111 = ADCLRCLK (when ADC is being used in master mode)
	10	PGA_UPD	0	PGA Ramp Control Clock Source Mux Update 0 = Do not update PGA clock source 1 = Update clock source

Table 24 Analogue Volume Ramp Control

ANALOGUE MUTE CONTROL

The analogue PGAs can be muted independently and are muted by default. Alternatively, all mute bits can be set using a master mute bit, MUTE_ALL.

Setting one of these mute bits is equivalent to setting the relevant PGAx_x_VOL[7:0] register bits to mute as defined in Table 22.

REGISTER ADDRESS	BIT	LABEL	DEFAULT	DESCRIPTION
R26 PGA_CTRL2 1Ah	0	MUTE_ ALL	0	Master PGA Mute Control 0 = Unmute all PGAs 1 = Mute all PGAs
	1	PGA1L_ MUTE	1	Individual PGA Mute Control 0 = Unmute PGA 1 = Mute PGA
	2	PGA1R_ MUTE	1	
	3	PGA2L_ MUTE	1	
	4	PGA2R_ MUTE	1	

Table 25 Analogue Mute Control

PGA ENABLE CONTROL

The PGAs are enabled using PGAx_x_EN bits as described in Table 26

REGISTER ADDRESS	BIT	LABEL	DEFAULT	DESCRIPTION
R31 INPUT_CTRL4 1Fh	0	PGA1L_ EN	0	PGA Enable Controls 0 = PGA disabled 1 = PGA enabled
	1	PGA1R_ EN		
	2	PGA2L_ EN		
	3	PGA2R_ EN		

Table 26 PGA Enable Control

ADC FEATURES

The WM8595 features a stereo 24-bit sigma-delta ADC, digital volume control with zero cross, a selectable high pass filter to remove DC offsets, and support for both master and slave clocking modes.

REGISTER ADDRESS	BIT	LABEL	DEFAULT	DESCRIPTION
R13 ADC_CTRL1 0Dh	6	ADC_EN	0	ADC Enable 0 = ADC disabled 1 = ADC enabled

Table 27 ADC Enable Control

ADC INPUT SELECTOR CONTROL

The ADC input switch can be configured to allow any combination of two inputs to be input to the ADC. Each input switch channel can be controlled independently.

The input switch also includes PGAs to provide a range of analogue gain settings between 0dB and +12dB prior to the ADC. These PGAs can be enabled and disabled independently.

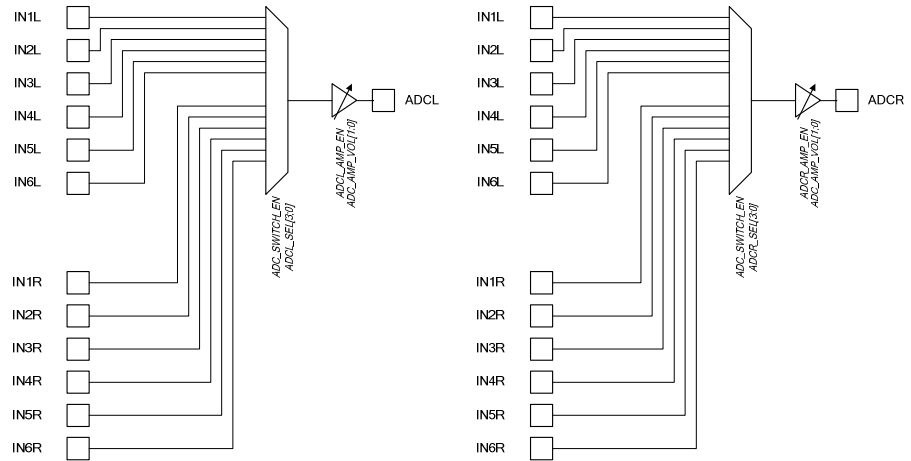

Figure 20 ADC Input Selector Control

REGISTER ADDRESS	BIT	LABEL	DEFAULT	DESCRIPTION
R30 INPUT_CTRL1 1Eh	3:0	ADCL_ SEL[3:0]	0000	ADC Input Select 0000 = IN1L 0001 = IN2L 0010 = IN3L 0011 = IN4L 0100 = IN5L 0101 = IN6L 0110 = Reserved 0111 = Reserved 1000 = IN1R 1001 = IN2R 1010 = IN3R 1011 = IN4R 1100 = IN5R 1101 = IN6R 1110 = Reserved 1111 = Reserved
	7:4	ADCR_ SEL[4:0]	1000	
	9:8	ADC_AMP _VOL[1:0]	10	ADC Amplifier Gain Control 00 = 0dB 01 = +3dB 10 = +6dB 11 = +12dB
	10	ADC_ SWITCH_ EN	0	ADC Input Switch Control 0 = ADC input switches open 1 = ADC input switches closed
R31 INPUT_CTRL2 1Fh	6	ADCL_ AMP_EN	0	ADC Input Amplifier Enable Controls 0 = Amplifier disabled 1 = Amplifier enabled
	7	ADCR_ AMP_EN	0	

Table 28 ADC Input Switch Control

DIGITAL VOLUME CONTROL

The ADC digital volume can be adjusted between +30dB and -97dB in 0.5dB steps. Left and right channels can be controlled independently. Volume changes can be applied immediately to each channel, or volume changes can be written to both channels before writing to an update bit in order to change the volume in both channels simultaneously.

Volume control includes optional zero cross functionality. When zero cross is enabled, volume changes are not applied until the output level crosses the DC level of the ADC output. Zero cross helps to prevent pop and click noise when changing volume settings.

REGISTER ADDRESS	BIT	LABEL	DEFAULT	DESCRIPTION
R16 ADCL_VOL 10h	7:0	ADCL_VOL[7:0]	11000011	ADC Digital Volume 0000 0000 = Digital mute 0000 0001 = -97dB
R17 ADCR_VOL 11h	7:0	ADCR_VOL[7:0]	11000011	0000 0010 = -96.5dB ...0.5dB steps 1100 0011 = 0dB ...0.5dB steps 1111 1110 = +29.5dB 1111 1111 = +30dB
R16 ADCL_VOL 10h	8	ADCL_VU	0	ADC Digital Volume Update 0 = Latch ADC volume setting into Register Map but do not update volume 1 = Latch ADC volume setting into Register Map and update left and right channels simultaneously
R17 ADCR_VOL 11h	8	ADCR_VU	0	
R13 ADC_CTRL1 0Dh	13	ADC_ZC_EN	1	ADC Digital Volume Control Zero Cross Enable 0 = Do not use zero cross, change volume instantly 1 = Use zero cross, change volume when data crosses zero

Table 29 ADC Digital Volume Control

CHANNEL SWAP AND INVERSION

The WM8595 ADC input channels can be inverted and swapped in a number of ways to provide maximum flexibility of input path to the ADC. The default configuration provides stereo output data with the left and right channel data in the left and right channels. It is possible to swap the left and right channels, invert them independently, or select the same data from both channels.

REGISTER ADDRESS	BIT	LABEL	DEFAULT	DESCRIPTION
R13 ADC_CTRL1 0Dh	7	ADC_ LRSWAP	0	ADC Left/Right Swap 0 = Normal 1 = Swap left channel data into right channel and vice-versa
	8	ADCR_ INV	0	ADCL and ADCR Output Signal Inversion 0 = Output not inverted 1 = Output inverted
	9	ADCL_ INV	0	1 = Output inverted
	11:10	ADC_ DATA_ SEL[1:0]	00	ADC Data Output Select 00 = left data from ADCL, right data from ADCR 01 = left data from ADCL, right data from ADCL 10 = left data from ADCR, right data from ADCR 11 = left data from ADCR, right data from ADCL

Table 30 ADC Channel Swap Control

HIGH PASS FILTER

The WM8595 includes a high pass filter to remove DC offsets. The high pass filter response is shown on page 77. It is possible to disable the high pass filter by writing to ADC_HPDP.

REGISTER ADDRESS	BIT	LABEL	DEFAULT	DESCRIPTION
R13 ADC_CTRL1 0Dh	12	ADC_HPDP	0	ADC High Pass Filter Disable 0 = High pass filter enabled 1 = High pass filter disabled

Table 31 High Pass Filter Disable Control

DIGITAL ROUTING CONTROL

The WM8595 includes a highly flexible digital routing multiplexer, allowing independent systems to be directly connected to the WM8595 without the need for glue logic. The WM8595 consists of two digital audio 'ports', each with four pins, which can be configured to connect to any of the three internal WM8595 systems (ADC, DAC1 or DAC2) or to any other digital audio ports. An additional ADC data pin and two GPIO pins are available as auxiliary bidirectional data pins. A simplified block diagram of the digital routing is shown in Figure 21:

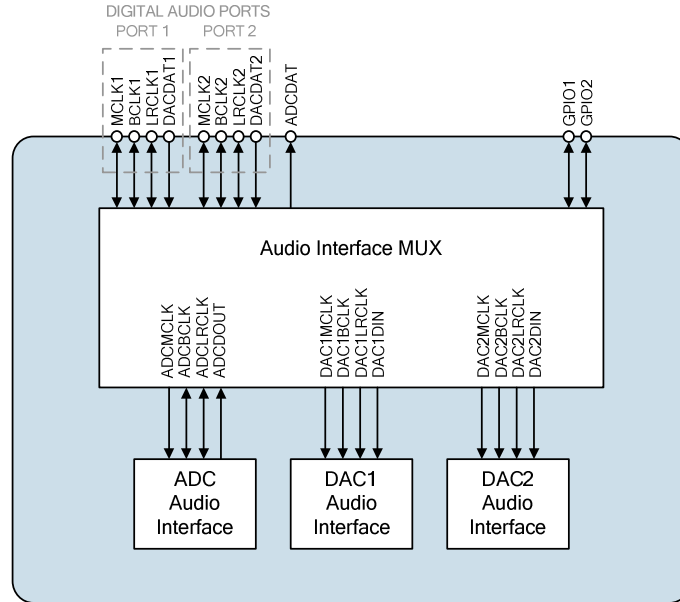

Figure 21 Digital Routing Block Diagram

The default configuration of the clocking is as shown in Figure 22 below. It is expected that this configuration will satisfy the majority of the use cases for the WM8595, but if it doesn't it is possible to route the signals differently. See the following pages for details of this setup.

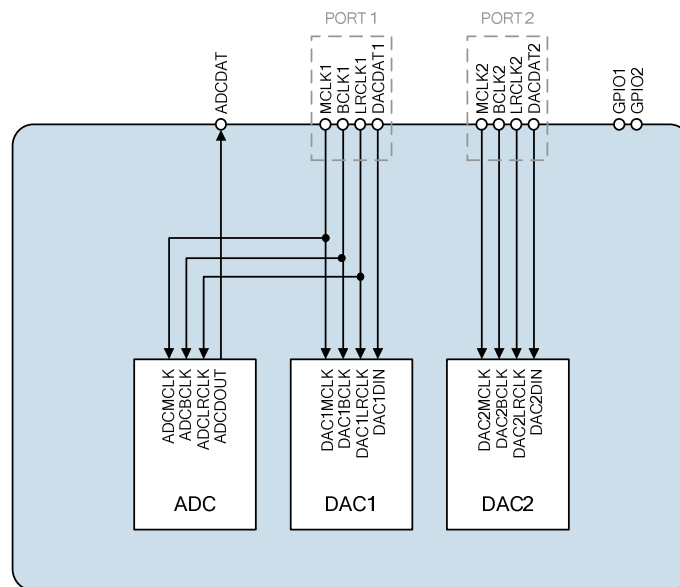

Figure 22 Default Clocking Configuration

DIGITAL AUDIO PORT PIN CONFIGURATION

The MCLK1 pin is defined as an input or an output using MCLK1_SEL[2:0]. The BCLK1 and LRCLK1 pins are always defined as inputs or outputs together using WORDCLK1_SEL[2:0]. DACDAT1 is always an input.

REGISTER ADDRESS	BIT	LABEL	DEFAULT	DESCRIPTION
R37 AIF_MUX1 25h	3:1	MCLK1_SEL[2:0]	000	MCLK1 Pin Function Select 000 = Input to WM8595 001 = Output MCLK2 010 to 111 = Reserved
	6:4	WORDCLK1_SEL[2:0]	000	BCLK1 and LRCLK1 Pins Function Select 000 = Inputs to WM8595 001 = Output BCLK2 and LRCLK2 010 to 110 = Reserved 111 = Output ADCBCLK and ADCBCLK (when ADC is master mode)

Table 32 Digital Audio Port 1 Pin Configuration

The MCLK2 pin is defined as an input or an output using MCLK2_SEL[2:0]. The BCLK2 and LRCLK2 pins are always defined as inputs or outputs together using WORDCLK2_SEL[2:0]. DACDAT2 is always an input.

REGISTER ADDRESS	BIT	LABEL	DEFAULT	DESCRIPTION
R38 AIF_MUX2 26h	3:1	MCLK2_SEL[2:0]	001	MCLK2 Pin Function Select 000 = Output MCLK1 001 = Input to WM8595 010 to 111 = Reserved
	6:4	WORDCLK2_SEL[2:0]	001	BCLK2 and LRCLK2 Pins Function Select 000 = Output BCLK1 and LRCLK1 001 = Inputs to WM8595 010 to 110 = Reserved 111 = Output ADCBCLK and ADCBCLK (when ADC is master mode)

Table 33 Digital Audio Port 2 Pin Configuration

ADC AUDIO INTERFACE CLOCK CONFIGURATION

The WM8595 ADC has an independent audio interface which can be configured to select the required signals from any of the digital audio ports. The audio interface is not restricted to take each signal from the same digital audio port, although the BCLK and LRCLK signals are selected together.

The MCLK is always an input to the ADC audio interface is selected using ADCMCLK_SEL[2:0]. The BCLK and LRCLK are always selected together, and can be either an input to the ADC audio interface (when the ADC is in slave mode) or an output from the ADC audio interface (when the ADC is in master mode). BCLK and LRCLK are selected using ADCWORDCLK_SEL[2:0].

REGISTER ADDRESS	BIT	LABEL	DEFAULT	DESCRIPTION
R44 AIF_MUX5 2Ch	3:1	ADC MCLK_ SEL[2:0]	000	ADCMCLK Select 000 = Use MCLK1 001 = Use MCLK2 010 to 111 = Reserved
	6:4	ADC WORD CLK_ SEL[2:0]	000	ADC BCLK and LRCLK Select 000 = Use BCLK1 and LRCLK1 001 = Use BCLK2 and LRCLK2 010 to 110 = Reserved 111 = Output ADCBCLK and ADCBCLK (when ADC is master mode)

Table 34 ADC Audio Interface Clock Configuration

DAC1 AND DAC2 AUDIO INTERFACE CLOCK CONFIGURATION

Both DACs on the WM8595 have independent audio interfaces which can be configured to select the required signals from any of the digital audio ports. The audio interfaces are not restricted to take each signal from the same digital audio ports, although the BCLK and LRCLK signals are selected together.

DAC1MCLK and DAC2MCLK are always inputs to the DAC1 and DAC2 audio interfaces and are selected using DAC1MCLK_SEL[2:0] and DAC2MCLK_SEL[2:0] respectively.

DAC1BCLK and DAC1LRCLK are always selected together and can be inputs to the DAC1 audio interface. DAC2BCLK and DAC2LRCLK are always selected together and are inputs to the DAC2 audio interface. DAC1BCLK and DAC1LRCLK are selected using DAC1WORDCLK_SEL[2:0], while DAC2BCLK and DAC2LRCLK are selected using DAC2WORDCLK_SEL[2:0].

REGISTER ADDRESS	BIT	LABEL	DEFAULT	DESCRIPTION
R42 AIF_MUX3 2Ah	3:1	DAC1 MCLK_ SEL[2:0]	000	DAC1 MCLK Select 000 = Use MCLK1 001 = Use MCLK2 010 to 111 = Reserved
R43 AIF_MUX4 2Bh		DAC2 MCLK_ SEL[2:0]	001	DAC2 MCLK Select 000 = Use MCLK1 001 = Use MCLK2 010 to 111 = Reserved
R42 AIF_MUX3 2Ah	6:4	DAC1 WORD CLK_ SEL[2:0]	000	DAC1 BCLK and DAC LRCLK Select 000 = Use BCLK1 and LRCLK1 001 = Use BCLK2 and LRCLK2 010 to 110 = Reserved 111 = Use ADCBCLK and ADCBCLK (when ADC is master mode)
R43 AIF_MUX4 2Bh		DAC2 WORD CLK_ SEL[2:0]	001	DAC2 BCLK and DAC LRCLK Select 000 = Use BCLK1 and LRCLK1 001 = Use BCLK2 and LRCLK2 010 to 110 = Reserved 111 = Use ADCBCLK and ADCBCLK (when ADC is master mode)
R42 AIF_MUX3 2Ah	9:7	DAC1 DIN_ SEL[2:0]	000	DAC1 DIN Select 000 = Use DACDAT1 001 = Use DACDAT2 010 to 100 = Reserved 101 = Use GPIO1 110 = Use GPIO2 111 = Reserved
R43 AIF_MUX4 2Bh	9:7	DAC2 DIN_ SEL[2:0]	001	DAC2 DIN Select 000 = Use DACDAT1 001 = Use DACDAT2 010 to 100 = Reserved 101 = Use GPIO1 110 = Use GPIO2 111 = Reserved

Table 35 DAC1 and DAC2 Audio Interface Clock Configuration

USING GPIO PINS AS ADDITIONAL DATA PINS

There are two GPIO pins, GPIO1 and GPIO2, which can be used as additional pins to connect to external devices. GPIO1 is controlled by GPIO1_SEL[2:0] and GPIO2 by GPIO2_SEL[2:0].

REGISTER ADDRESS	BIT	LABEL	DEFAULT	DESCRIPTION
R45 AIF_MUX9 2Dh	3:1	GPIO1_ SEL[2:0]	101	GPIO1 Pin Function Select 000 = Source DACDAT1 001 = Source DACDAT2 010 = Source ADCDAT 011 to 100 = Reserved 101 = Input to WM8595 110 = Source GPIO2 111 = Source ADC Data Output

Table 36 GPIO1 Audio Interface Mux Configuration

REGISTER ADDRESS	BIT	LABEL	DEFAULT	DESCRIPTION
R46 AIF_MUX10 2Eh	3:1	GPIO2_ SEL[2:0]	000	GPIO2 Pin Function Select 000 = Source DACDAT1 001 = Source DACDAT2 010 = Source ADCDAT 011 to 100 = Reserved 101 = Source GPIO1 110 = Input to WM8595 111 = Source ADC Data Output

Table 37 GPIO2 Audio Interface Mux Configuration

UPDATE FUNCTION

To prevent clock contention issues during setup of the digital audio interface mux, an update system has been implemented. This allows the registers to be configured as required and the update to be applied with the last register write synchronise the configuration of the digital audio mux. An update can be generated using any of the update bits shown in Table 38.

REGISTER ADDRESS	BIT	LABEL	DEFAULT	DESCRIPTION
R37 AIF_MUX1 25h	10	PORT1_ UPD	0	Update 0 = Latch corresponding settings into Register Map but do not update 1 = Latch corresponding settings into Register Map and update all simultaneously
R38 AIF_MUX2 26h	10	PORT2_ UPD		
R42 AIF_MUX3 2Ah	10	DAC1_ UPD		
R43 AIF_MUX4 2Bh	10	DAC2_ UPD		
R44 AIF_MUX5 2Ch	10	ADC_ UPD		
R45 AIF_MUX6 2Dh	10	GPIO1_ UPD		
R46 AIF_MUX7 2Eh	10	GPIO2_ UPD		

Table 38 Audio Interface Mux Update Bits

POP AND CLICK PERFORMANCE

The WM8595 includes a number of features designed to minimise pops and clicks in various phases of operation including power up, power down, changing analogue paths and starting/stopping clocks. In order to ensure optimum performance, the following sequences should be followed.

POWERUP SEQUENCE

1. Apply power to the WM8595 (see Power On Reset).
2. Set-up initial internal biases:
 - SOFT_ST=1
 - FAST_EN=1
 - POBCTRL=1
 - BUFIO_EN=1
3. Enable output drivers to allow the AC coupling capacitors at the output stage to be pre-charged to VMID2C:
 - VOUTxL_EN=1
 - VOUTxR_EN=1
4. Enable VMID2C. Highest resistance string selected here for optimum pop reduction:
 - VMID_SEL=10
5. Wait until VMID2C has fully charged. The time is dependent on the capacitor values used to AC-couple the outputs and to decouple VMID2C, and the VMID_SEL value chosen. An approximate delay of $6xRCms$ can be used, where R is the VMID2C resistance (between AVDD1 and VMID2C) and C is the decoupling capacitor on VMID2C, although this time should be determined by the customer using the exact application configuration for best results.
 - Insert delay
6. Enable the master bias and VMID2C buffer:
 - BIAS_EN=1
7. Switch the output drivers to use the master bias instead of the power up (fast) bias:
 - POBCTRL=0
8. Enable all functions (DACs, ADC, PGAs) required for use. Outputs are muted by default so the write order is not important.
9. Unmute the PGAs and switch VMID2C resistance to mid setting for normal operation:
 - PGAxL_MUTE=0
 - PGAxR_MUTE=0
 - VMID_SEL=01

POWERDOWN SEQUENCE

1. Mute all PGAs:
 - MUTE_ALL=1
2. Set up biases for power down mode:
 - FAST_EN=1
 - VMID_SEL=01
 - BIAS_EN=1
 - BUFIO_EN=1
 - VMIDTOG=0
 - SOFT_ST=1
3. Switch outputs to use fast bias instead of master bias:
 - POBCTRL=1
4. Power down all WM8595 functions (ADC, DACs, PGAs etc.). The outputs are muted so the write order is not important.
5. Power down VMID to allow the analogue outputs to ramp gently to ground in a pop-free manner.
 - VMID_SEL=00
6. Wait until VMID2C has fully discharged. The time taken depends on system capacitance and should be evaluated by the customer in their application.
 - Insert delay
7. Clamp outputs to ground.
 - APE_B=0
8. Power down outputs.
 - VOUTxL_EN=0
 - VOUTxR_EN=0
9. Disable remaining bias control bits.
 - FAST_EN=0
 - POBCTRL=0
 - BIAS_EN=0

Power supplies can now be safely removed from the WM8595 if desired.

Table 39 describes the various bias control bits for power up/down control:

REGISTER ADDRESS	BIT	LABEL	DEFAULT	DESCRIPTION
R35 BIAS 23h	0	POBCTRL	0	Bias Source for Output Amplifiers 0 = Output amplifiers use master bias 1 = Output amplifiers use fast bias
	1	VMIDTOG	0	VMID Power Down Characteristic 0 = Slow ramp 1 = Fast ramp
	2	FAST_EN	0	Fast Bias Enable 0 = Fast bias disabled 1 = Fast bias enabled
	3	BUFIO_EN	0	VMID Buffer Enable 0 = VMID Buffer disabled 1 = VMID Buffer enabled
	4	SOFT_ST	1	VMID Soft Ramp Enable 0 = Soft ramp disabled 1 = Soft ramp enabled
	5	BIAS_EN	0	Master Bias Enable 0 = Master bias disabled 1 = Master bias enabled Also powers down VMID1C
	7:6	VMID_SEL[1:0]	00	VMID Resistor String Value Selection (VMID2C only) 00 = off (no VMID) 01 = 38k 10 = 127k 11 = 12.5k The selection is the total resistance of the string from VREF2VDD to VREF2GND. The VMID1C resistance is fixed at 200kΩ.

Table 39 Bias Control

GLOBAL ENABLE CONTROL

The WM8595 includes a number of enable and disable mechanisms to allow the device to be powered on and off in a pop-free manner. A global enable control bit enables the ADC, DAC and analogue paths.

REGISTER ADDRESS	BIT	LABEL	DEFAULT	DESCRIPTION
R12 ENABLE 0Ch	0	GLOBAL_EN	0	Device Global Enable 0 = ADC, DAC and PGA ramp control circuitry disabled 1 = ADC, DAC and PGA ramp control circuitry enabled

Table 40 Global Enable Control

EMERGENCY POWER DOWN

In the event of sudden power failure in a system, or any other emergency condition, the SHUTDOWN pin may be used to power the device down from any state in a controlled manner. This may be useful in a system where there is no guarantee the power supplies will be available long enough to complete the recommended power down sequence using software writes.

When the SHUTDOWN is pulled low, the device will mute and then power down the outputs quietly. If the WM8595 is still receiving clocks, the outputs will be softmuted. If the clocks have stopped, the outputs will be muted immediately. Figure 23 shows the operation of SHUTDOWN and the effect on the outputs of the device:

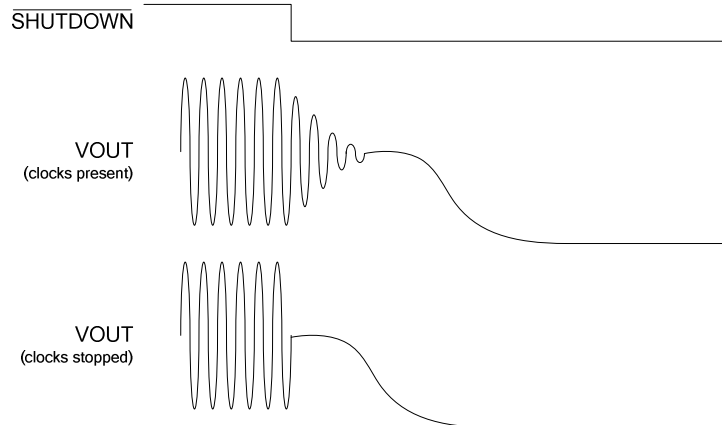

Figure 23 SHUTDOWN Operation

It is expected that power is removed from the device before the device is used again, forcing the device to be reset via the POR. If this is not the case, the device must be manually reset by the customer (either by a software or hardware reset) once the SHUTDOWN is pulled high again.

REGISTER MAP

Dec Address	Hex Addr Name	15	14	13	12	11	10	9	8	7	6	5	4	3	2	1	0	Hex Default
0	00 DEVICE_ID	0	0	0	0	0	0	0	0	0	0	0	0	0	0	0	0	0x8595
1	01 REVISION	0	0	0	0	0	0	0	0	0	0	0	0	0	0	0	0	0x0000
2	02 DAC1_CTRL1	0	0	0	0	DAC1_OP_MUX[1:0]	DAC1_MUTE	DAC1_EN	DAC1_ZCEN	DAC1_DEEMPH	DAC1_LRP	DAC1_BCP	DAC1_WL[1:0]	DAC1_FM[1:0]	DAC1_SR[2:0]	0	0	0x008A
3	03 DAC1_CTRL2	0	0	0	0	0	0	0	0	0	0	0	0	0	0	0	0	0x0000
5	05 DAC1L_VOL	0	0	0	0	0	0	DAC1L_VU	0	0	0	0	0	0	0	0	0	0x00C8
6	06 DAC1R_VOL	0	0	0	0	0	0	DAC1R_VU	0	0	0	0	0	0	0	0	0	0x00C8
7	07 DAC2_CTRL1	0	0	0	0	DAC2_OP_MUX[1:0]	DAC2_MUTE	DAC2_EN	DAC2_ZCEN	DAC2_DEEMPH	DAC2_LRP	DAC2_BCP	DAC2_WL[1:0]	DAC2_FM[1:0]	DAC2_SR[2:0]	0	0	0x008A
8	08 DAC2_CTRL2	0	0	0	0	0	0	0	0	0	0	0	0	0	0	0	0	0x0000
10	0A DAC2L_VOL	0	0	0	0	0	0	DAC2L_VU	0	0	0	0	0	0	0	0	0	0x00C8
11	0B DAC2R_VOL	0	0	0	0	0	0	DAC2R_VU	0	0	0	0	0	0	0	0	0	0x00C8
12	0C ENABLE	0	0	0	0	0	0	0	0	0	0	0	0	0	0	0	0	0x0000
13	0D ADC_CTRL1	0	0	ADC_ZC_EN	ADC_HPD	ADC_DATA_SEL[1:0]	ADCL_INV	ADCR_INV	ADC_IRSWAP	ADC_EN	ADC_LRP	ADC_BCP	ADC_WL[1:0]	ADC_SR[2:0]	ADC_COPY_DAC1	GLOBAL_EN	0	0x200A
14	0E ADC_CTRL2	0	0	0	0	0	0	0	0	0	0	0	0	0	0	0	0	0x0000
15	0F ADC_CTRL3	0	0	0	0	0	0	0	0	0	0	0	0	0	0	0	0	0x0000
16	10 ADCL_VOL	0	0	0	0	0	0	ADCL_VU	0	0	0	0	0	0	0	0	0	0x00C3
17	11 ADCR_VOL	0	0	0	0	0	0	ADCR_VU	0	0	0	0	0	0	0	0	0	0x00C3
19	13 PGA1L_VOL	0	0	0	0	0	0	PGA1L_VU	0	0	0	0	0	0	0	0	0	0x000C
20	14 PGA1R_VOL	0	0	0	0	0	0	PGA1R_VU	0	0	0	0	0	0	0	0	0	0x000C
21	15 PGA2L_VOL	0	0	0	0	0	0	PGA2L_VU	0	0	0	0	0	0	0	0	0	0x000C
22	16 PGA2R_VOL	0	0	0	0	0	0	PGA2R_VU	0	0	0	0	0	0	0	0	0	0x000C
25	19 PGA_CTRL1	0	0	0	0	0	0	0	0	0	0	0	0	0	0	0	0	0x0000
26	1A PGA_CTRL2	0	0	0	0	0	0	0	0	0	0	0	0	0	0	0	0	0x007E
27	1B GEN	0	0	0	0	0	0	0	0	0	0	0	0	0	0	0	0	0x0048
30	1E INPUT_CTRL1	0	0	0	0	0	0	0	0	0	0	0	0	0	0	0	0	0x0080
31	1F INPUT_CTRL2	0	0	0	0	0	0	0	0	0	0	0	0	0	0	0	0	0x0000
34	22 OUTPUT_CTRL	0	0	0	0	0	0	0	0	0	0	0	0	0	0	0	0	0x0040
35	23 BIAS	0	0	0	0	0	0	0	0	0	0	0	0	0	0	0	0	0x0010
36	24 PGA_CTRL3	0	0	0	0	0	0	0	0	0	0	0	0	0	0	0	0	0x0002
37	25 AIF_MUX1	0	0	0	0	0	0	0	0	0	0	0	0	0	0	0	0	0x0000
38	26 AIF_MUX2	0	0	0	0	0	0	0	0	0	0	0	0	0	0	0	0	0x0000
42	2A AIF_MUX3	0	0	0	0	0	0	0	0	0	0	0	0	0	0	0	0	0x0000
43	28 AIF_MUX4	0	0	0	0	0	0	0	0	0	0	0	0	0	0	0	0	0x0092
44	2C AIF_MUX5	0	0	0	0	0	0	0	0	0	0	0	0	0	0	0	0	0x0000
45	2D AIF_MUX6	0	0	0	0	0	0	0	0	0	0	0	0	0	0	0	0	0x000A
46	2E AIF_MUX7	0	0	0	0	0	0	0	0	0	0	0	0	0	0	0	0	0x000C

R0 (0h) – Software Reset / Device ID Register (DEVICE_ID)								
Bit #	15	14	13	12	11	10	9	8
Read	DEVICE_ID[15:8]							
Write	SW_RST							
Default	1	0	0	0	0	1	0	1
Bit #	7	6	5	4	3	2	1	0
Read	DEVICE_ID[7:0]							
Write	SW_RST							
Default	1	0	0	1	0	1	0	1
N/A = Not Applicable (no function implemented)								
Function	Description							
DEVICEID[15:0]	Device ID A read of this register will return the device ID. In this case 0x8595.							
SW_RST	Software Reset A write of any value to this register will generate a software reset.							

Figure 24 R0 – Software Reset / Device ID

R1 (01h) – Device Revision Register (REVISION)								
Bit #	15	14	13	12	11	10	9	8
Read	0	0	0	0	0	0	0	0
Write	N/A	N/A	N/A	N/A	N/A	N/A	N/A	N/A
Default	0	0	0	0	0	0	0	0
Bit #	7	6	5	4	3	2	1	0
Read	REVNUM[7:0]							
Write	N/A	N/A	N/A	N/A	N/A	N/A	N/A	N/A
Default	-	-	-	-	-	-	-	-
N/A = Not Applicable (no function implemented)								
Function	Description							
REVNUM[7:0]	Device Revision A read of this register will return the device revision number. This number is sequentially incremented if the device design is updated.							

Figure 25 R1 – Device Revision Register

R2 (02h) – DAC Control Register 1 (DAC1_CTRL1)								
Bit #	15	14	13	12	11	10	9	8
Read	0	0	0	0	DAC1_OP_MUX[1:0]		DAC1_MUTE	DAC1_EN
Write	N/A	N/A	N/A	N/A				
Default	0	0	0	0	0	0	0	0
Bit #	7	6	5	4	3	2	1	0
Read	DAC1_ZCEN	DAC1_DEEMPH	DAC1_LRP	DAC1_BCP	DAC1_WL[1:0]		DAC1_FMT[1:0]	
Write								
Default	1	0	0	0	1	0	1	0
N/A = Not Applicable (no function implemented)								
Function	Description							
DAC1_FMT[1:0]	DAC1 Audio Interface Format 00 = Right Justified 01 = Left Justified 10 = I ² S 11 = DSP							
DAC1_WL[1:0]	DAC1 Audio Interface Word Length 00 = 16-bit 01 = 20-bit 10 = 24-bit 11 = 32-bit (not available in Right Justified mode)							
DAC1_BCP	DAC1 BCLK Polarity 0 = DACBCLK not inverted – data latched on rising edge of BCLK 1 = DACBCLK inverted – data latched on falling edge of BCLK							
DAC1_LRP	DAC1 LRCLK Polarity 0 = DACLRCLK not inverted 1 = DACLRCLK inverted							
DAC1_DEEMPH	DAC1 Deemphasis 0 = No deemphasis 1 = Apply 44.1kHz deemphasis							
DAC1_ZCEN	DAC1 Digital Volume Control Zero Cross Enable 0 = Do not use zero cross 1 = Use zero cross							
DAC1_EN	DAC1 Enable 0 = DAC disabled 1 = DAC enabled							
DAC1_MUTE	DAC1 Softmute 0 = Normal operation 1 = Softmute applied							
DAC1_OP_MUX[1:0]	DAC1 Digital Monomix 00 = Stereo (Normal Operation) 01 = Mono (Left data to DAC1R) 10 = Mono (Right data to DAC1L) 11 = Digital Monomix, (L+R)/2							

Figure 26 R2 – DAC1 Control Register 1

R3 (03h) – DAC1 Control Register 2 (DAC1_CTRL2)								
Bit #	15	14	13	12	11	10	9	8
Read	0	0	0	0	0	0	0	0
Write	N/A	N/A	N/A	N/A	N/A	N/A	N/A	N/A
Default	0	0	0	0	0	0	0	0
Bit #	7	6	5	4	3	2	1	0
Read	0	0	0	0	0	DAC1_SR[2:0]		
Write	N/A	N/A	N/A	N/A	N/A	DAC1_SR[2:0]		
Default	0	0	0	0	0	0	0	0
N/A = Not Applicable (no function implemented)								
Function	Description							
DAC1_SR[2:0]	DAC1 MCLK:LRCLK Ratio 000 = Auto detect 001 = 128fs 010 = 192fs 011 = 256fs 100 = 384fs 101 = 512fs 110 = 768fs 111 = 1152fs							

Figure 27 R3 – DAC1 Control Register 2

R5 (05h) – DAC1L Digital Volume Control Register (DAC1L_VOL)								
Bit #	15	14	13	12	11	10	9	8
Read	0	0	0	0	0	0	0	DAC1L_VU
Write	N/A	N/A	N/A	N/A	N/A	N/A	N/A	
Default	0	0	0	0	0	0	0	0
Bit #	7	6	5	4	3	2	1	0
Read	DAC1L_VOL[7:0]							
Write	DAC1L_VOL[7:0]							
Default	1	1	0	0	1	0	0	0
N/A = Not Applicable (no function implemented)								
Function	Description							
DAC1L_VOL[7:0]	DAC1L Digital Volume 0000 0000 = -100dB 0000 0001 = -99.5dB 0000 0010 = -99dB ...0.5dB steps 1100 1000 = 0dB ...0.5dB steps 1101 1111 = +11.5dB 111X XXXX = +12dB							
DAC1L_VU	DAC1L Digital Volume Update 0 = Latch DAC1L_VOL[7:0] into Register Map but do not update volume 1 = Latch DAC1L_VOL[7:0] into Register Map and update left and right channels simultaneously							

Figure 28 R5 – DAC1L Digital Volume Control Register

R6 (06h) – DAC1R Digital Volume Control Register (DAC1R_VOL)								
Bit #	15	14	13	12	11	10	9	8
Read	0	0	0	0	0	0	0	DAC1R_VU
Write	N/A	N/A	N/A	N/A	N/A	N/A	N/A	
Default	0	0	0	0	0	0	0	0
Bit #	7	6	5	4	3	2	1	0
Read	DAC1R_VOL[7:0]							
Write	DAC1R_VOL[7:0]							
Default	1	1	0	0	1	0	0	0
N/A = Not Applicable (no function implemented)								
Function	Description							
DAC1R_VOL[7:0]	DAC1R Digital Volume 0000 0000 = -100dB 0000 0001 = -99.5dB 0000 0010 = -99dB ...0.5dB steps 1100 1000 = 0dB ...0.5dB steps 1101 1111 = +11.5dB 111X XXXX = +12dB							
DAC1R_VU	DAC1R Digital Volume Update 0 = Latch DACR_VOL[7:0] into Register Map but do not update volume 1 = Latch DACR_VOL[7:0] into Register Map and update left and right channels simultaneously							

Figure 29 R6 – DAC1R Digital Volume Control Register

R7 (07h) – DAC2 Control Register 1 (DAC2_CTRL1)								
Bit #	15	14	13	12	11	10	9	8
Read	0	0	0	0	DAC2_OP_MUX[1:0]		DAC2_MUTE	DAC2_EN
Write	N/A	N/A	N/A	N/A				
Default	0	0	0	0	0	0	0	0
N/A = Not Applicable (no function implemented)								
Bit #	7	6	5	4	3	2	1	0
Read	DAC2_ZCEN	DAC2_DEEMPH	DAC2_LRP	DAC2_BCP	DAC2_WL[1:0]		DAC2_FMT[1:0]	
Write								
Default	1	0	0	0	1	0	1	0
Function	Description							
DAC2_FMT[1:0]	DAC2 Audio Interface Format 00 = Right Justified 01 = Left Justified 10 = I ² S 11 = DSP							
DAC2_WL[1:0]	DAC2 Audio Interface Word Length 00 = 16-bit 01 = 20-bit 10 = 24-bit 11 = 32-bit (not available in Right Justified mode)							
DAC2_BCP	DAC2 BCLK Polarity 0 = DACBCLK not inverted – data latched on rising edge of BCLK 1 = DACBCLK inverted – data latched on falling edge of BCLK							
DAC2_LRP	DAC2 LRCLK Polarity 0 = DACLRCLK not inverted 1 = DACLRCLK inverted							
DAC2_DEEMPH	DAC2 Deemphasis 0 = No deemphasis 1 = Apply 44.1kHz deemphasis							
DAC2_ZCEN	DAC2 Digital Volume Control Zero Cross Enable 0 = Do not use zero cross 1 = Use zero cross							
DAC2_EN	DAC2 Enable 0 = DAC2 disabled 1 = DAC2 enabled							
DAC2_MUTE	DAC2 Softmute 0 = Normal operation 1 = Softmute applied							
DAC2_OP_MUX[1:0]	DAC2 Digital Monomix 00 = Stereo (Normal Operation) 01 = Mono (Left data to Right DAC2) 10 = Mono (Right data to Left DAC2) 11 = Digital Monomix, (L+R)/2							

Figure 30 R7 – DAC2 Control Register 1

R8 (08h) – DAC2 Control Register 2 (DAC2_CTRL2)								
Bit #	15	14	13	12	11	10	9	8
Read	0	0	0	0	0	0	0	0
Write	N/A	N/A	N/A	N/A	N/A	N/A	N/A	N/A
Default	0	0	0	0	0	0	0	0
Bit #	7	6	5	4	3	2	1	0
Read	0	0	0	0	0	DAC2_SR[2:0]		
Write	N/A	N/A	N/A	N/A	N/A	DAC2_SR[2:0]		
Default	0	0	0	0	0	0	0	0
N/A = Not Applicable (no function implemented)								
Function	Description							
DAC2_SR[2:0]	DAC2 MCLK:LRCLK Ratio 000 = Auto detect 001 = 128fs 010 = 192fs 011 = 256fs 100 = 384fs 101 = 512fs 110 = 768fs 111 = 1152fs							

Figure 31 R8 – DAC2 Control Register 2

R10 (0Ah) – DAC2L Digital Volume Control Register (DAC2L_VOL)								
Bit #	15	14	13	12	11	10	9	8
Read	0	0	0	0	0	0	0	DAC2L_VU
Write	N/A	N/A	N/A	N/A	N/A	N/A	N/A	
Default	0	0	0	0	0	0	0	0
Bit #	7	6	5	4	3	2	1	0
Read	DAC2L_VOL[7:0]							
Write	DAC2L_VOL[7:0]							
Default	1	1	0	0	1	0	0	0
N/A = Not Applicable (no function implemented)								
Function	Description							
DAC2L_VOL[7:0]	DAC2 Digital Volume 0000 0000 = -100dB 0000 0001 = -99.5dB 0000 0010 = -99dB ...0.5dB steps 1100 1000 = 0dB ...0.5dB steps 1101 1111 = +11.5dB 111X XXXX = +12dB							
DAC2L_VU	DAC2 Digital Volume Update 0 = Latch DAC2L_VOL[7:0] into Register Map but do not update volume 1 = Latch DAC2L_VOL[7:0] into Register Map and update left and right channels simultaneously							

Figure 32 R10 – DAC2L Digital Volume Control Register

R11 (0Bh) – DAC2R Digital Volume Control Register (DAC2R_VOL)								
Bit #	15	14	13	12	11	10	9	8
Read	0	0	0	0	0	0	0	DAC2R_VU
Write	N/A	N/A	N/A	N/A	N/A	N/A	N/A	
Default	0	0	0	0	0	0	0	0
Bit #	7	6	5	4	3	2	1	0
Read	DAC2R_VOL[7:0]							
Write	DAC2R_VOL[7:0]							
Default	1	1	0	0	1	0	0	0
N/A = Not Applicable (no function implemented)								
Function	Description							
DAC2R_VOL[7:0]	DAC2R Digital Volume 0000 0000 = -100dB 0000 0001 = -99.5dB 0000 0010 = -99dB ...0.5dB steps 1100 1000 = 0dB ...0.5dB steps 1101 1111 = +11.5dB 111X XXXX = +12dB							
DAC2R_VU	DAC2R Digital Volume Update 0 = Latch DAC2R_VOL[7:0] into Register Map but do not update volume 1 = Latch DAC2R_VOL[7:0] into Register Map and update left and right channels simultaneously							

Figure 33 R11 – DAC2R Digital Volume Control Register

R12 (0Ch) – Device Enable Register (ENABLE)								
Bit #	15	14	13	12	11	10	9	8
Read	0	0	0	0	0	0	0	0
Write	N/A	N/A	N/A	N/A	N/A	N/A	N/A	N/A
Default	0	0	0	0	0	0	0	0
Bit #	7	6	5	4	3	2	1	0
Read	0	0	0	0	0	0	DAC2_	GLOBAL_EN
Write	N/A	N/A	N/A	N/A	N/A	N/A	COPY_DAC1	
Default	0	0	0	0	0	0	0	0
N/A = Not Applicable (no function implemented)								
Function	Description							
GLOBAL_EN	Device Global Enable 0 = ADC, DAC and PGA ramp control circuitry disabled 1 = ADC, DAC and PGA ramp control circuitry enabled							
DAC2_COPY_DAC1	DAC2 Configuration Control 0 = DAC2 settings independent of DAC1 1 = DAC2 settings are the same as DAC1							

Figure 34 R12 – Device Enable Register

R13 (0Dh) – ADC Control Register 1 (ADC_CTRL1)								
Bit #	15	14	13	12	11	10	9	8
Read	0	0	ADC_ZCEN	ADC_HPD	ADC_DATA_SEL[1:0]		ADCL_INV	ADCR_INV
Write	N/A	N/A						
Default	0	0	1	0	0	0	0	0
N/A = Not Applicable (no function implemented)								
Bit #	7	6	5	4	3	2	1	0
Read	ADC_LRSWAP	ADC_EN	ADC_LRP	ADC_BCP	ADC_WL[1:0]		ADC_FMT[1:0]	
Write								
Default	0	0	0	0	1	0	1	0
Function	Description							
ADC_FMT[1:0]	ADC Audio Interface Format 00 = Right Justified 01 = Left Justified 10 = I ² S 11 = DSP							
ADC_WL[1:0]	ADC Audio Interface Word Length 00 = 16-bit 01 = 20-bit 10 = 24-bit 11 = 32-bit (not available in Right Justified mode)							
ADC_BCP	ADC BCLK Polarity 0 = ADCBCLK not inverted – data latched on rising edge of BCLK 1 = ADCBCLK inverted – data latched on falling edge of BCLK							
ADC_LRP	ADC LRCLK Polarity 0 = ADCLRCLK not inverted 1 = ADCLRCLK inverted							
ADC_EN	ADC Enable 0 = ADC disabled 1 = ADC enabled							
ADC_LRSWAP	ADC Left/Right Swap 0 = Normal 1 = Swap left channel data into right channel and vice-versa							
ADCR_INV ADCL_INV	ADCL and ADCR Output Signal Inversion 0 = Output not inverted 1 = Output inverted							
ADC_DATA_SEL[1:0]	ADC Data Output Select 00 = left data from ADCL, right data from ADCR (Normal Stereo) 01 = left data from ADCL, right data from ADCL (Mono Left) 10 = left data from ADCR, right data from ADCR (Mono Right) 11 = left data from ADCR, right data from ADCL (Reverse Stereo)							
ADC_HPD	ADC High Pass Filter Disable 0 = High pass filter enabled 1 = High pass filter disabled							
ADC_ZC_EN	ADC Digital Volume Control Zero Cross Enable 0 = Do not use zero cross, change volume instantly 1 = Use zero cross, change volume when data crosses zero							

Figure 35 R13 – ADC Control Register 1

R14 (0Eh) – ADC Control Register 2 (ADC_CTRL2)								
Bit #	15	14	13	12	11	10	9	8
Read	0	0	0	0	0	0	0	0
Write	N/A	N/A	N/A	N/A	N/A	N/A	N/A	N/A
Default	0	0	0	0	0	0	0	0
Bit #	7	6	5	4	3	2	1	0
Read	0	0	ADC_BCLKDIV[2:0]			ADC_SR[2:0]		
Write	N/A	N/A						
Default	0	0	0	0	0	0	0	0
N/A = Not Applicable (no function implemented)								
Function	Description							
ADC_SR[2:0]	ADC MCLK:LRCLK Ratio 000 = Auto detect 001 = reserved 010 = reserved 011 = 256fs 100 = 384fs 101 = 512fs 110 = 768fs 111 = Reserved							
ADC_BCLKDIV[2:0]	ADC BCLK Rate (when ADC in Master Mode) 000 = MCLK / 4 001 = MCLK / 8 010 = 32fs 011 = 64fs 100 = 128fs All other values of ADC_BCLKDIV[2:0] are reserved							

Figure 36 R14 – ADC Control Register 2

R15 (0Fh) – ADC Control Register 3 (ADC_CTRL3)								
Bit #	15	14	13	12	11	10	9	8
Read	0	0	0	0	0	0	0	0
Write	N/A	N/A	N/A	N/A	N/A	N/A	N/A	N/A
Default	0	0	0	0	0	0	0	0
Bit #	7	6	5	4	3	2	1	0
Read	0	0	0	0	0	0	0	ADC_MSTR
Write	N/A	N/A	N/A	N/A	N/A	N/A	N/A	
Default	0	0	0	0	0	0	0	0
N/A = Not Applicable (no function implemented)								
Function	Description							
ADC_MSTR	ADC Master Mode Select 0 = Slave mode, ADCBCLK and ADCLRCLK are inputs to WM8595 1 = Master mode, ADCBCLK and ADCLRCLK are outputs from WM8595							

Figure 37 R15 – ADC Control Register 3

R16 (10h) – Left ADC Digital Volume Control Register (ADCL_VOL)								
Bit #	15	14	13	12	11	10	9	8
Read	0	0	0	0	0	0	0	ADCL_VU
Write	N/A	N/A	N/A	N/A	N/A	N/A	N/A	
Default	0	0	0	0	0	0	0	0
N/A = Not Applicable (no function implemented)								
Bit #	7	6	5	4	3	2	1	0
Read	ADCL_VOL[7:0]							
Write	ADCL_VOL[7:0]							
Default	1	1	0	0	0	0	1	1
N/A = Not Applicable (no function implemented)								
Function	Description							
ADCL_VOL[7:0]	Left ADC Digital Volume 0000 0000 = Digital mute 0000 0001 = -97dB 0000 0010 = -96.5dB ...0.5dB steps 1100 0011 = 0dB ...0.5dB steps 1111 1110 = +29.5dB 1111 1111 = +30dB							
ADCL_VU	Left DAC Digital Volume Update 0 = Latch ADCL_VOL[7:0] into Register Map but do not update volume 1 = Latch ADCL_VOL[7:0] into Register Map and update left and right channels simultaneously							

Figure 38 R16 – Left ADC Digital Volume Control Register

R17 (11h) – Right ADC Digital Volume Control Register (ADCR_VOL)								
Bit #	15	14	13	12	11	10	9	8
Read	0	0	0	0	0	0	0	ADCR_VU
Write	N/A	N/A	N/A	N/A	N/A	N/A	N/A	
Default	0	0	0	0	0	0	0	0
N/A = Not Applicable (no function implemented)								
Bit #	7	6	5	4	3	2	1	0
Read	ADCR_VOL[7:0]							
Write	ADCR_VOL[7:0]							
Default	1	1	0	0	0	0	1	1
N/A = Not Applicable (no function implemented)								
Function	Description							
ADCR_VOL[7:0]	Right ADC Digital Volume 0000 0000 = Digital mute 0000 0001 = -97dB 0000 0010 = -96.5dB ...0.5dB steps 1100 0011 = 0dB ...0.5dB steps 1111 1110 = +29.5dB 1111 1111 = +30dB							
ADCR_VU	Right ADC Digital Volume Update 0 = Latch ADCR_VOL[7:0] into Register Map but do not update volume 1 = Latch ADCR_VOL[7:0] into Register Map and update left and right channels simultaneously							

Figure 39 R17 – Right ADC Digital Volume Control Register

R19 (13h) – PGA1L Volume Control Register (PGA1L_VOL)								
Bit #	15	14	13	12	11	10	9	8
Read	0	0	0	0	0	0	0	0
Write	N/A	N/A	N/A	N/A	N/A	N/A	N/A	PGA1L_VU
Default	0	0	0	0	0	0	0	0
R19 (13h) – PGA1L Volume Control Register (PGA1L_VOL)								
Bit #	7	6	5	4	3	2	1	0
Read	PGA1L_VOL[7:0]							
Write	PGA1L_VOL[7:0]							
Default	0	0	0	0	1	1	0	0
N/A = Not Applicable (no function implemented)								
R20 (14h) – PGA1R Volume Control Register (PGA1R_VOL)								
Bit #	15	14	13	12	11	10	9	8
Read	0	0	0	0	0	0	0	0
Write	N/A	N/A	N/A	N/A	N/A	N/A	N/A	PGA1R_VU
Default	0	0	0	0	0	0	0	0
R20 (14h) – PGA1R Volume Control Register (PGA1R_VOL)								
Bit #	7	6	5	4	3	2	1	0
Read	PGA1R_VOL[7:0]							
Write	PGA1R_VOL[7:0]							
Default	0	0	0	0	1	1	0	0
N/A = Not Applicable (no function implemented)								
R21 (15h) – PGA2L Volume Control Register (PGA2L_VOL)								
Bit #	15	14	13	12	11	10	9	8
Read	0	0	0	0	0	0	0	0
Write	N/A	N/A	N/A	N/A	N/A	N/A	N/A	PGA2L_VU
Default	0	0	0	0	0	0	0	0
R21 (15h) – PGA2L Volume Control Register (PGA2L_VOL)								
Bit #	7	6	5	4	3	2	1	0
Read	PGA2L_VOL[7:0]							
Write	PGA2L_VOL[7:0]							
Default	0	0	0	0	1	1	0	0
N/A = Not Applicable (no function implemented)								
R22 (16h) – PGA2R Volume Control Register (PGA2R_VOL)								
Bit #	15	14	13	12	11	10	9	8
Read	0	0	0	0	0	0	0	0
Write	N/A	N/A	N/A	N/A	N/A	N/A	N/A	PGA2R_VU
Default	0	0	0	0	0	0	0	0
R22 (16h) – PGA2R Volume Control Register (PGA2R_VOL)								
Bit #	7	6	5	4	3	2	1	0
Read	PGA2R_VOL[7:0]							
Write	PGA2R_VOL[7:0]							
Default	0	0	0	0	1	1	0	0
N/A = Not Applicable (no function implemented)								

...Continued on next page

Function	Description
PGA1L_VOL[7:0] PGA1R_VOL[7:0] PGA2L_VOL[7:0] PGA2R_VOL[7:0]	Input PGA Volume 0000 0000 = +6dB 0000 0001 = +5.5dB ...0.5dB steps 00001100 = 0dB ... 1001 1110 = -73.5dB 1001 1111 = PGA Mute
PGA1L_VU PGA1R_VU PGA2L_VU PGA2R_VU	Input PGA Volume Update 0 = Latch corresponding volume setting into Register Map but do not update volume 1 = Latch corresponding volume setting into Register Map and update all channels simultaneously

Figure 40 R19-24 – PGA Volume Control Registers

R25 (19h) – PGA Control Register 1 (PGA_CTRL1)								
Bit #	15	14	13	12	11	10	9	8
Read	0	0	0	0	0	0	0	0
Write	N/A	N/A	N/A	N/A	N/A	N/A	N/A	N/A
Default	0	0	0	0	0	0	0	0
Bit #	7	6	5	4	3	2	1	0
Read	0	0	PGA2R_ZC	PGA2L_ZC	PGA1R_ZC	PGA1L_ZC	ATTACK_	DECAY_
Write	N/A	N/A						
Default	0	0	0	0	0	0	0	0
N/A = Not Applicable (no function implemented)								
Function	Description							
DECAY_BYPASS	PGA Gain Decay Mode 0 = PGA gain will ramp down 1 = PGA gain will step down							
ATTACK_BYPASS	PGA Gain Attack Mode 0 = PGA gain will ramp up 1 = PGA gain will step up							
PGA1L_ZC PGA1R_ZC PGA2L_ZC PGA2R_ZC	PGA Gain Zero Cross Enable 0 = PGA gain updates occur immediately 1 = PGA gain updates occur on zero cross Zero cross must be disabled to use gain ramp							

Figure 41 R25 – PGA Control Register 1

R26 (1Ah) – PGA Control Register 2 (PGA_CTRL2)								
Bit #	15	14	13	12	11	10	9	8
Read	0	0	0	0	0	0	0	0
Write	N/A	N/A	N/A	N/A	N/A	N/A	N/A	N/A
Default	0	0	0	0	0	0	0	0
Bit #	7	6	5	4	3	2	1	0
Read	0	0	0	PGA2R_	PGA2L_	PGA1R_	PGA1L_	MUTE_ALL
Write	N/A	N/A	N/A	MUTE	MUTE	MUTE	MUTE	
Default	0	1	1	1	1	1	1	0
N/A = Not Applicable (no function implemented)								
Function	Description							
MUTE_ALL	Master PGA Mute Control 0 = Unmute all output drivers 1 = Mute all output drivers							
PGA1L_MUTE PGA1R_MUTE PGA2L_MUTE PGA2R_MUTE	Individual PGA Mute Control 0 = Unmute output driver 1 = Mute output driver							

Figure 42 R26 – PGA Control Register 2

R27 (1Bh) – Additional Control Register 1 (ADD_CTRL1)								
Bit #	15	14	13	12	11	10	9	8
Read	0	0	0	0	0	0	0	0
Write	N/A	N/A	N/A	N/A	N/A	N/A	N/A	N/A
Default	0	0	0	0	0	0	0	0
Bit #	7	6	5	4	3	2	1	0
Read	0	PGA_SR[2:0]			AUTO_INC	0	0	0
Write	N/A					N/A	N/A	N/A
Default	0	1	0	0	1	0	0	0
N/A = Not Applicable (no function implemented)								
Function	Description							
AUTO_INC	2-wire Software Mode Auto Increment Enable 0 = Auto increment disabled 1 = Auto increment enabled							
PGA_SR[2:0]	Sample Rate for PGA 000 = 32kHz 001 = 44.1kHz 010 = 48kHz 011 = 88.2kHz 100 = 96kHz 101 = 176.4kHz 11X = 192kHz See Table 23 for further information on PGA sample rate versus volume ramp rate.							

Figure 43 R27 – Additional Control Register 1

R30 (1Eh) – Input Control Register 1 (INPUT_CTRL1)								
Bit #	15	14	13	12	11	10	9	8
Read	0	0	0	0	0	ADC_ SWITCH_EN	ADC_AMP_VOL[1:0]	
Write	N/A	N/A	N/A	N/A	N/A			
Default	0	0	0	0	0	0	1	0
N/A = Not Applicable (no function implemented)								
Bit #	7	6	5	4	3	2	1	0
Read	ADCR_SEL[3:0]				ADCL_SEL[3:0]			
Write	ADCR_SEL[3:0]				ADCL_SEL[3:0]			
Default	1	0	0	0	0	0	0	0
Function	Description							
ADCL_SEL[3:0] ADCR_SEL[3:0]	ADC Input Select 0000 = IN1L 0001 = IN2L 0010 = IN3L 0011 = IN4L 0100 = IN5L 0101 = IN6L 0110 = Reserved 0111 = Reserved 1000 = IN1R 1001 = IN2R 1010 = IN3R 1011 = IN4R 1100 = IN5R 1101 = IN6R 1110 = Reserved 1111 = Reserved							
ADC_AMP_VOL[1:0]	ADC Amplifier Gain Control 00 = 0dB 01 = +3dB 10 = +6dB 11 = +12dB							
ADC_SWITCH_EN	ADC Input Switch Control 0 = ADC input switches open 1 = ADC input switches closed							

Figure 44 R30 – Input Control Register 1

R31 (1Fh) – Input Control Register 2 (INPUT_CTRL2)								
Bit #	15	14	13	12	11	10	9	8
Read	0	0	0	0	0	0	0	0
Write	N/A	N/A	N/A	N/A	N/A	N/A	N/A	N/A
Default	0	0	0	0	0	0	0	0
Bit #	7	6	5	4	3	2	1	0
Read	ADCR_AMP_	ADCL_AMP_	0	0	PGA2R_EN	PGA2L_EN	PGA1R_EN	PGA1L_EN
Write	EN	EN	N/A	N/A				
Default	0	0	0	0	0	0	0	0
N/A = Not Applicable (no function implemented)								
Function	Description							
PGA1L_EN PGA1R_EN PGA2L_EN PGA2R_EN	Input PGA Enable Controls 0 = PGA disabled 1 = PGA enabled							
ADCL_AMP_EN ADCR_AMP_EN	ADC Input Amplifier Enable Controls 0 = Amplifier disabled 1 = Amplifier enabled							

Figure 45 R31 – Input Control Register 2

R34 (22h) – Output Control Register 3 (OUTPUT_CTRL)								
Bit #	15	14	13	12	11	10	9	8
Read	0	0	0	0	0	VOUT2R_EN	VOUT2L_EN	VOUT1R_EN
Write	N/A	N/A	N/A	N/A	N/A			
Default	0	0	0	0	0	0	0	0
Bit #	7	6	5	4	3	2	1	0
Read	VOUT1L_EN	APE_B	0	0	VOUT2R_TRI	VOUT2L_TRI	VOUT1R_TRI	VOUT1L_TRI
Write			N/A	N/A				
Default	0	1	0	0	0	0	0	0
N/A = Not Applicable (no function implemented)								
Function	Description							
VOUT1L_TRI VOUT1R_TRI VOUT2L_TRI VOUT2R_TRI	Output Amplifier Tristate Control 0 = Normal operation 1 = Output amplifier tristate enable (Hi-Z)							
APE_B	Clamp Outputs to Ground 0 = clamp active 1 = clamp not active							
VOUT1L_EN VOUT1R_EN VOUT2L_EN VOUT2R_EN	Output Amplifier Enables 0 = Output amplifier disabled 1 = Output amplifier enabled							

Figure 46 R34 – Output Control Register

R35 (23h) – Bias Control Register (BIAS)								
Bit #	15	14	13	12	11	10	9	8
Read	0	0	0	0	0	0	0	0
Write	N/A	N/A	N/A	N/A	N/A	N/A	N/A	N/A
Default	0	0	0	0	0	0	0	0
Bit #	7	6	5	4	3	2	1	0
Read	VMID_SEL[1:0]		BIAS_EN	SOFT_ST	BUFIO_EN	FAST_EN	VMIDTOG	POBCTRL
Write	VMID_SEL[1:0]		BIAS_EN	SOFT_ST	BUFIO_EN	FAST_EN	VMIDTOG	POBCTRL
Default	0	0	0	1	0	0	0	0
N/A = Not Applicable (no function implemented)								
Function	Description							
POBCTRL	Bias Source for Output Amplifiers 0 = Output amplifiers use master bias 1 = Output amplifiers use fast bias							
VMIDTOG	VMID Power Down Characteristic 0 = Slow ramp 1 = Fast ramp							
FAST_EN	Fast Bias Enable 0 = Fast bias disabled 1 = Fast bias enabled							
BUFIO_EN	VMID Buffer Enable 0 = VMID Buffer disabled 1 = VMID Buffer enabled							
SOFT_ST	VMID Soft Ramp Enable 0 = Soft ramp disabled 1 = Soft ramp enabled							
BIAS_EN	Master Bias Enable 0 = Master bias disabled 1 = Master bias enabled Also powers down VMID1C							
VMID_SEL[1:0]	VMID Resistor String Value Selection (VMID2C only) 00 = off (no VMID) 01 = 38k 10 = 127k 11 = 12.5k The selection is the total resistance of the string from VREF2VDD to VREF2GND. The VMID1C resistance is fixed at 200k.							

Figure 47 R35 – Bias Control Register

R36 (24h) – PGA Control Register 3 (PGA_CTRL)								
Bit #	15	14	13	12	11	10	9	8
Read	0	0	0	0	0	PGA_UPD	0	0
Write	N/A	N/A	N/A	N/A	N/A		N/A	N/A
Default	0	0	0	0	0	0	0	0
Bit #	7	6	5	4	3	2	1	0
Read	0	0	0	0	PGA_SEL[2:0]			0
Write	N/A	N/A	N/A	N/A				N/A
Default	0	0	0	0	0	0	1	0
N/A = Not Applicable (no function implemented)								
Function	Description							
PGA_SEL[2:0]	PGA Ramp Control Clock Source 000 = LRCLK1 001 = LRCLK2 010 to 110 = Reserved 111 = ADCLRCLK (when ADC is being used in master mode)							
PGA_UPD	PGA Ramp Control Clock Source Mux Update 0 = Do not update PGA clock source 1 = Update clock source							

Figure 48 R36 – PGA Control Register

R37 (25h) – Audio Interface MUX Configuration Register 1 (AIF_MUX1)								
Bit #	15	14	13	12	11	10	9	8
Read	0	0	0	0	0	PORT1_UPD	0	0
Write	N/A	N/A	N/A	N/A	N/A		N/A	N/A
Default	0	0	0	0	0	0	0	0
N/A = Not Applicable (no function implemented)								
Bit #	7	6	5	4	3	2	1	0
Read	0	WORDCLK1_SEL[2:0]			MCLK1_SEL[2:0]			0
Write	N/A							N/A
Default	0	0	0	0	0	0	0	0
N/A = Not Applicable (no function implemented)								
Function	Description							
MCLK1_SEL[2:0]	MCLK1 Pin Function Select 000 = Input to WM8595 001 = Output MCLK2 010 to 111 = Reserved							
WORDCLK1_SEL[2:0]	BCLK1 and LRCLK1 Pins Function Select 000 = Inputs to WM8595 001 = Output BCLK2 and LRCLK2 010 to 110 = Reserved 111 = Output ADCBCLK and ADCBCLK (when ADC is master mode)							
PORT1_UPD	Port 1 Update 0 = Latch corresponding Port 1 settings into Register Map but do not update 1 = Latch corresponding Port 1 settings into Register Map and update all simultaneously							

Figure 49 R37 – Audio Interface MUX Configuration Register 1

R38 (26h) – Audio Interface MUX Configuration Register 2 (AIF_MUX2)								
Bit #	15	14	13	12	11	10	9	8
Read	0	0	0	0	0	PORT2_UPD	0	0
Write	N/A	N/A	N/A	N/A	N/A		N/A	N/A
Default	0	0	0	0	0	0	0	0
Bit #	7	6	5	4	3	2	1	0
Read	0	WORDCLK2_SEL[2:0]			MCLK2_SEL[2:0]			0
Write	N/A							N/A
Default	1	0	0	1	0	0	1	0
N/A = Not Applicable (no function implemented)								
Function		Description						
MCLK2_SEL[2:0]		MCLK2 Pin Function Select 000 = Output MCLK1 001 = Input to WM8595 010 = Output MCLK3 011 = Output MCLK4 100 = Output MCLK5 101 to 111 = Reserved						
WORDCLK2_SEL[2:0]		BCLK2 and LRCLK2 Pins Function Select 000 = Output BCLK1 and LRCLK1 001 = Inputs to WM8595 010 = Output BCLK3 and LRCLK3 011 = Output BCLK4 and LRCLK4 100 = Output BCLK5 and LRCLK5 101 = Output DAC1BCLK and DAC1LRCLK (when DAC1 is in master mode) 110 = Output DAC2BCLK and DAC2LRCLK (when DAC2 is in master mode) 111 = Output ADCBCLK and ADCBCLK (when ADC is master mode)						
PORT2_UPD		Port 2 Update 0 = Latch corresponding Port 2 settings into Register Map but do not update 1 = Latch corresponding Port 2 settings into Register Map and update all simultaneously						

Figure 50 R38 – Audio Interface MUX Configuration Register 2

R42 (2Ah) – Audio Interface MUX Configuration Register 3 (AIF_MUX3)								
Bit #	15	14	13	12	11	10	9	8
Read	0	0	0	0	0	DAC1_UPD	DAC1DIN_SEL[2:1]	
Write	N/A	N/A	N/A	N/A	N/A			
Default	0	0	0	0	0	0	0	0
Bit #	7	6	5	4	3	2	1	0
Read	DAC1DIN_SEL[0]	DAC1WORDCLK_SEL[2:0]			DAC1MCLK_SEL[2:0]			0
Write		N/A	0			0		
Default	0	0	0	0	0	0	0	0
N/A = Not Applicable (no function implemented)								
Function	Description							
DAC1MCLK_SEL[2:0]	DAC1MCLK Select 000 = Use MCLK1 001 = Use MCLK2 010 to 111 = Reserved							
DAC1WORDCLK_SEL[2:0]	DAC1BCLK and DAC1LRCLK Select 000 = Use BCLK1 and LRCLK1 001 = Use BCLK2 and LRCLK2 010 to 110 = Reserved 111 = Use ADCBCLK and ADCBCLK (when ADC is master mode)							
DAC1DIN_SEL[2:0]	DAC1DIN Select 000 = Use DACDAT1 001 = Use DACDAT2 010 to 100 = Reserved 101 = Use GPIO1 110 = Use GPIO2 111 = Reserved							
DAC1_UPD	DAC1 Clock Update 0 = Latch corresponding DAC1 clock settings into Register Map but do not update 1 = Latch corresponding DAC1 clock settings into Register Map and update all simultaneously							

Figure 51 R42 – Audio Interface MUX Configuration Register 3

R43 (2Bh) – Audio Interface MUX Configuration Register 4 (AIF_MUX4)								
Bit #	15	14	13	12	11	10	9	8
Read	0	0	0	0	0	DAC2_UPD	DAC2DIN_SEL[2:1]	
Write	N/A	N/A	N/A	N/A	N/A			
Default	0	0	0	0	0	0	0	0
Bit #	7	6	5	4	3	2	1	0
Read	DAC2DIN_SEL[0]	DAC2WORDCLK_SEL[2:0]			DAC2MCLK_SEL[2:0]			0
Write		N/A						
Default	1	0	0	1	0	0	1	0
N/A = Not Applicable (no function implemented)								
Function		Description						
DAC2MCLK_SEL[2:0]		DAC2MCLK Select 000 = Use MCLK1 001 = Use MCLK2 010 to 111 = Reserved						
DAC2WORDCLK_SEL[2:0]		DAC2BCLK and DAC2LRCLK Select 000 = Use BCLK1 and LRCLK1 001 = Use BCLK2 and LRCLK2 010 to 110 = Reserved 111 = Use ADCBCLK and ADCBCLK (when ADC is master mode)						
DAC2DIN_SEL[2:0]		DAC2DIN Select 000 = Use DACDAT1 001 = Use DACDAT2 010 to 100 = Reserved 101 = Use GPIO1 110 = Use GPIO2 111 = Reserved						
DAC2_UPD		DAC2 Clock Update 0 = Latch corresponding DAC2 clock settings into Register Map but do not update 1 = Latch corresponding DAC2 clock settings into Register Map and update all simultaneously						

Figure 52 R43 – Audio Interface MUX Configuration Register 4

R44 (2Ch) – Audio Interface MUX Configuration Register 5 (AIF_MUX5)								
Bit #	15	14	13	12	11	10	9	8
Read	0	0	0	0	0	ADC_UPD	0	0
Write	N/A	N/A	N/A	N/A	N/A		N/A	N/A
Default	0	0	0	0	0	0	0	0
N/A = Not Applicable (no function implemented)								
Bit #	7	6	5	4	3	2	1	0
Read	0	ADCWORDCLK_SEL[2:0]			ADCMCLK_SEL[2:0]			0
Write	N/A							N/A
Default	0	0	0	0	0	0	0	0
N/A = Not Applicable (no function implemented)								
Function		Description						
ADCMCLK_SEL[2:0]		ADCMCLK Select 000 = Use MCLK1 001 = Use MCLK2 010 to 111 = Reserved						
ADCWORDCLK_SEL[2:0]		ADCBCLK and ADCLRCLK Select 000 = Use BCLK1 and LRCLK1 001 = Use BCLK2 and LRCLK2 010 to 110 = Reserved 111 = Output ADCBCLK and ADCBCLK (when ADC is master mode)						
ADC_UPD		ADC Clock Update 0 = Latch corresponding ADC clock settings into Register Map but do not update 1 = Latch corresponding ADC clock settings into Register Map and update all simultaneously						

Figure 53 R44 – Audio Interface MUX Configuration Register 5

R45 (2Dh) – Audio Interface MUX Configuration Register 6 (AIF_MUX6)								
Bit #	15	14	13	12	11	10	9	8
Read	0	0	0	0	0	GPIO1_UPD	0	0
Write	N/A	N/A	N/A	N/A	N/A		N/A	N/A
Default	0	0	0	0	0	0	0	0
Bit #	7	6	5	4	3	2	1	0
Read	0	0	0	0	GPIO1_SEL[2:0]			0
Write	N/A	N/A	N/A	N/A				N/A
Default	0	0	0	0	1	0	1	0
N/A = Not Applicable (no function implemented)								
Function	Description							
GPIO1_SEL[2:0]	GPIO1 Pin Function Select 000 = Source DACDAT1 001 = Source DACDAT2 010 = Source ADCDAT 011 to 100 = Reserved 101 = Input to WM8595 110 = Source GPIO2 111 = Source ADC Data Output							
GPIO1_UPD	GPIO1 Update 0 = Latch corresponding GPIO1 settings into Register Map but do not update 1 = Latch corresponding GPIO1 settings into Register Map and update							

Figure 54 R45 – Audio Interface MUX Configuration Register 6

R46 (2Eh) – Audio Interface MUX Configuration Register 7 (AIF_MUX7)								
Bit #	15	14	13	12	11	10	9	8
Read	0	0	0	0	0	GPIO2_UPD	0	0
Write	N/A	N/A	N/A	N/A	N/A		N/A	N/A
Default	0	0	0	0	0	0	0	0
Bit #	7	6	5	4	3	2	1	0
Read	0	0	0	0	GPIO2_SEL[2:0]			0
Write	N/A	N/A	N/A	N/A				N/A
Default	0	0	0	0	1	1	0	0
N/A = Not Applicable (no function implemented)								
Function	Description							
GPIO2_SEL[2:0]	GPIO2 Pin Function Select 000 = Source DACDAT1 001 = Source DACDAT2 010 = Source ADCDAT 011 to 100 = Reserved 101 = Source GPIO1 110 = Input to WM8595 111 = Source ADC Data Output							
GPIO2_UPD	GPIO2 Update 0 = Latch corresponding GPIO2 settings into Register Map but do not update 1 = Latch corresponding GPIO2 settings into Register Map and update all simultaneously							

Figure 55 R46 – Audio Interface MUX Configuration Register 7

DIGITAL FILTER CHARACTERISTICS

PARAMETER	TEST CONDITIONS	MIN	TYP	MAX	UNIT
ADC Filter					
Passband	$\pm 0.05\text{dB}$			0.454fs	
Passband Ripple				0.05	dB
Stopband		0.546fs			
Stopband Attenuation		-60			dB
Group Delay			16		fs
DAC Filter – 32kHz to 96kHz					
Passband	$\pm 0.1\text{dB}$			0.454fs	
Passband Ripple				0.1	dB
Stopband		0.546fs			
Stopband attenuation	$f > 0.546\text{fs}$	-50			dB
Group Delay			10		Fs
DAC Filter – 176.4kHz to 192kHz					
Passband	$\pm 0.1\text{dB}$			0.247fs	
Passband Ripple				0.1	dB
Stopband		0.753fs			
Stopband attenuation	$f > 0.546\text{fs}$	-50			dB
Group Delay			10		Fs

DAC FILTER RESPONSES

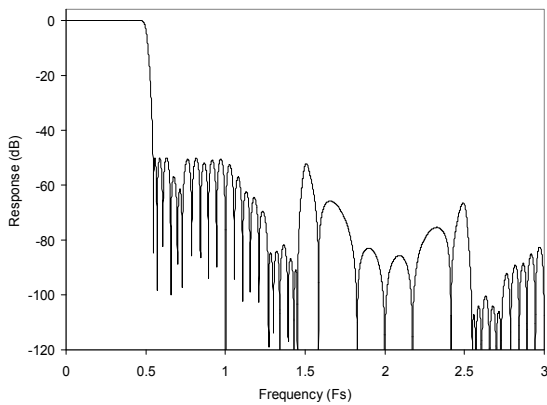

Figure 56 DAC Digital Filter Frequency Response – 44.1, 48 and 96KHz

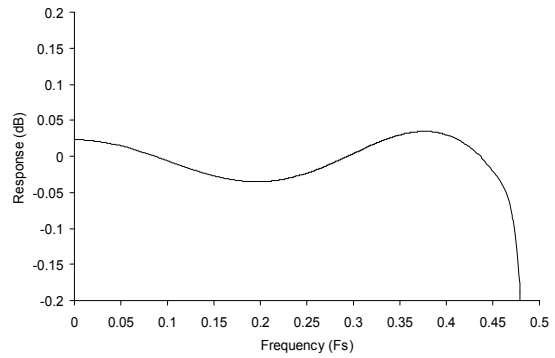

Figure 57 DAC Digital Filter Ripple –44.1, 48 and 96kHz

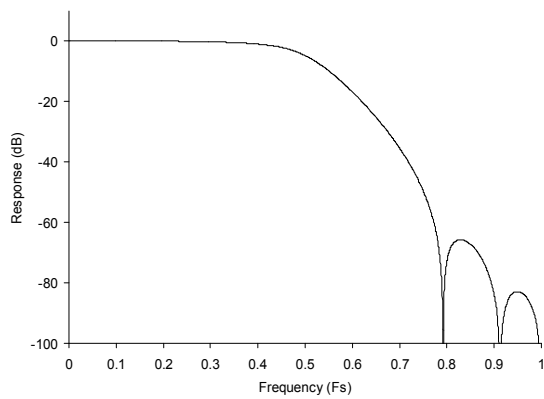

Figure 58 DAC Digital Filter Frequency Response – 192KHz

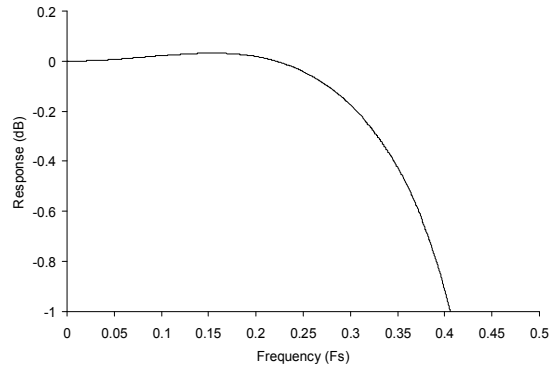

Figure 59 DAC Digital Filter Ripple – 192kHz

DIGITAL DE-EMPHASIS CHARACTERISTICS

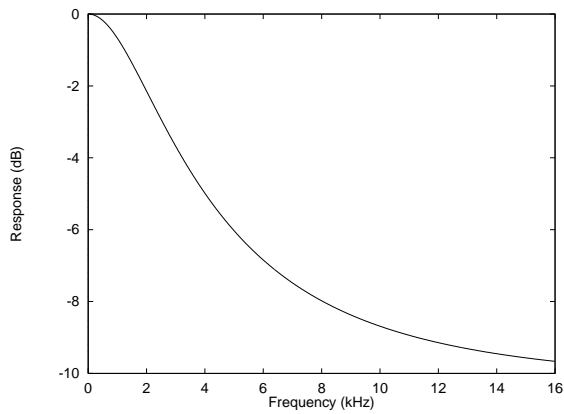

Figure 60 De-Emphasis Frequency Response (32kHz)

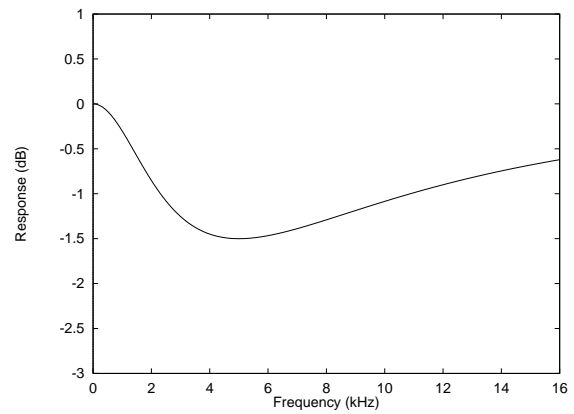

Figure 61 De-Emphasis Error (32kHz)

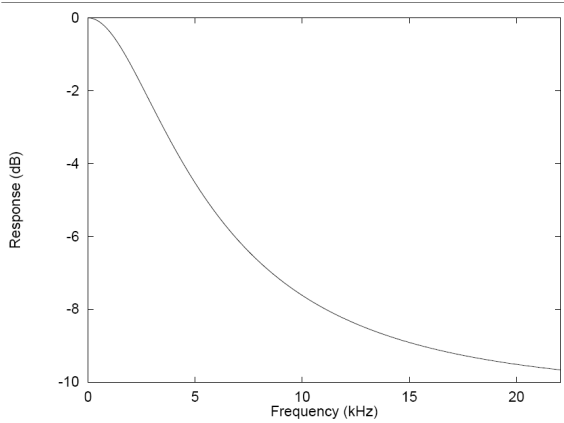

Figure 62 De-Emphasis Frequency Response (44.1kHz)

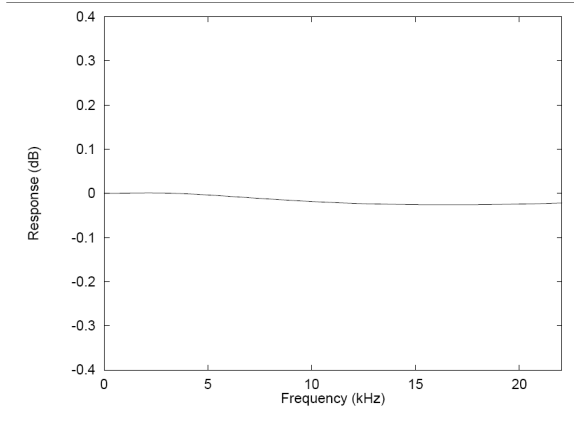

Figure 63 De-Emphasis Error (44.1kHz)

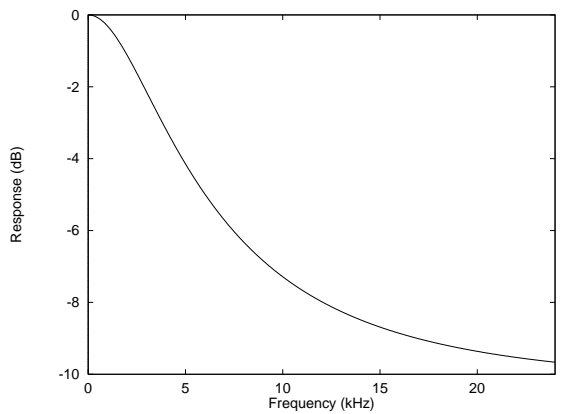

Figure 64 De-Emphasis Frequency Response (48kHz)

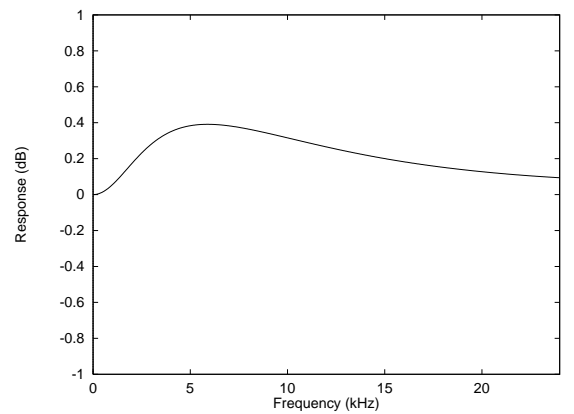

Figure 65 De-Emphasis Error (48kHz)

ADC FILTER RESPONSES

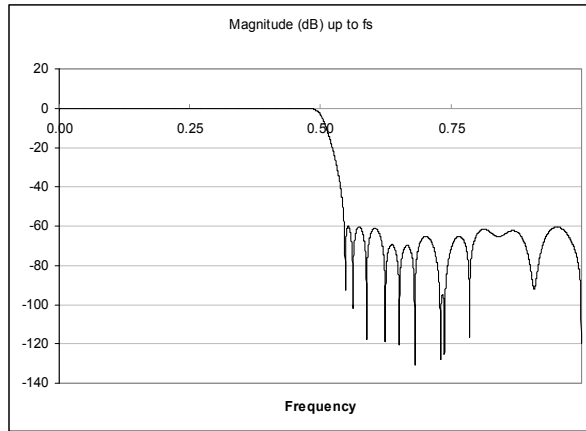

Figure 66 ADC Digital Filter Frequency Response

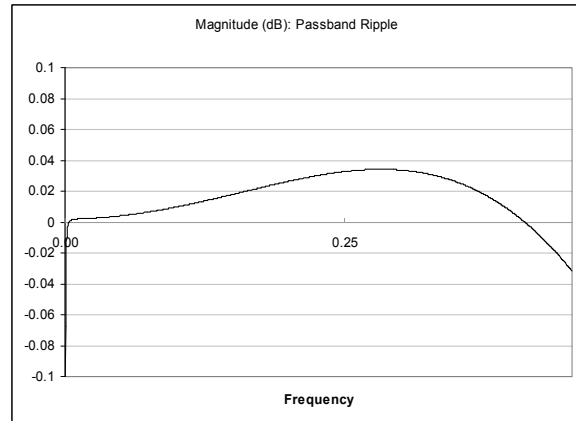

Figure 67 ADC Digital Filter Ripple

ADC HIGH PASS FILTER

The WM8595 has a selectable digital high pass filter to remove DC offsets. The filter response is characterised by the following polynomial.

$$H(z) = \frac{1 - z^{-1}}{1 - 0.9995z^{-1}}$$

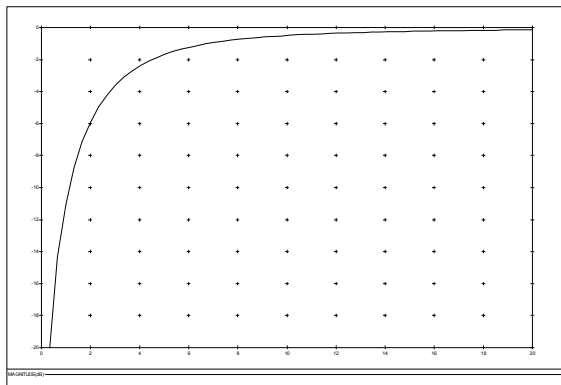
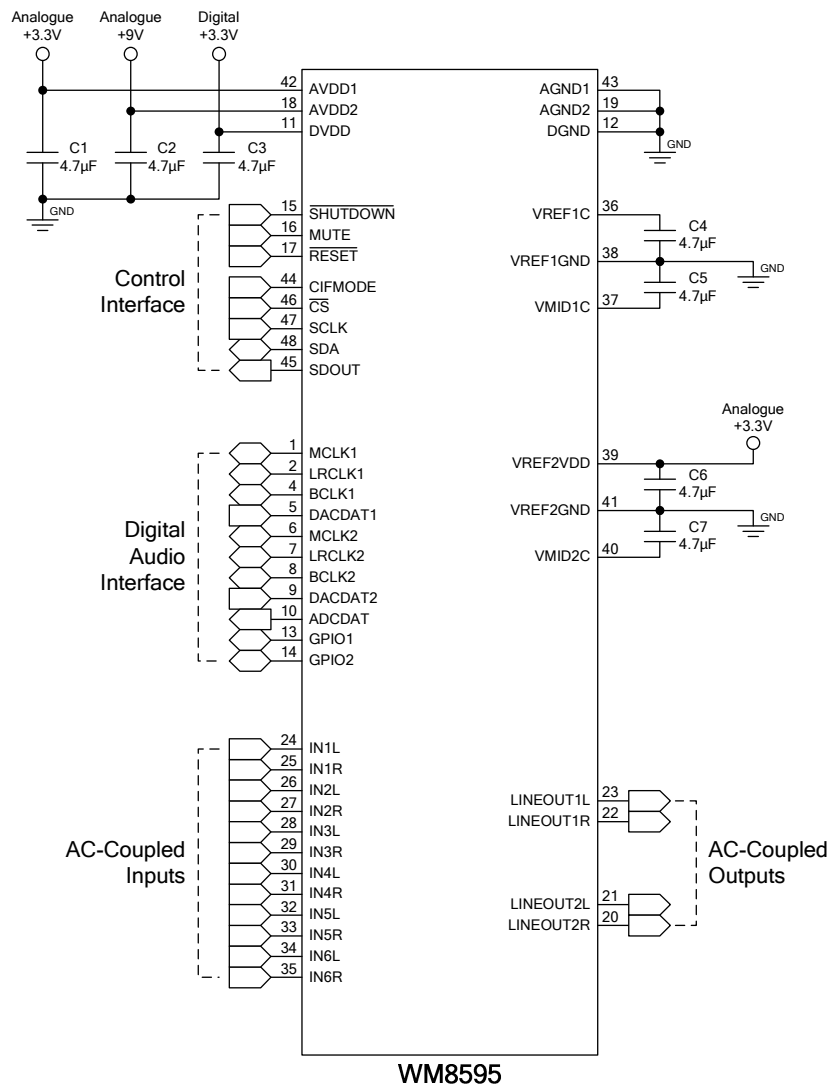

Figure 68 ADC Highpass Filter Response

APPLICATIONS INFORMATION

RECOMMENDED EXTERNAL COMPONENTS



Notes:

1. AGND and DGND should ideally share a continuous ground plane. Where this is not possible, it is recommended that AGND and DGND are connected as close to the WM8595 as possible.
2. Decoupling capacitors shown are very low-ESR, multilayer ceramic capacitors and should be placed as near to the WM8595 as possible. Equally good audio performance may be obtained using 0.1µF ceramic capacitors near to the WM8595, with a 10µF electrolytic capacitor nearby. Note that power up time is a function of the VMID2C resistor string setting and the decoupling capacitor C7.
3. The exposed paddle on the bottom of the QFN package should be connected to AGND

RECOMMENDED ANALOGUE LOW PASS FILTER

Figure 69 Recommended Analogue Low Pass Filter (shown for VOUT1L/R)

Note: See WAN0176 for AC coupling capacitor selection information.

An external single pole RC filter is recommended (see Figure 69) if the device is driving a wideband amplifier. Other filter architectures may provide equally good results.

RELEVANT APPLICATION NOTES

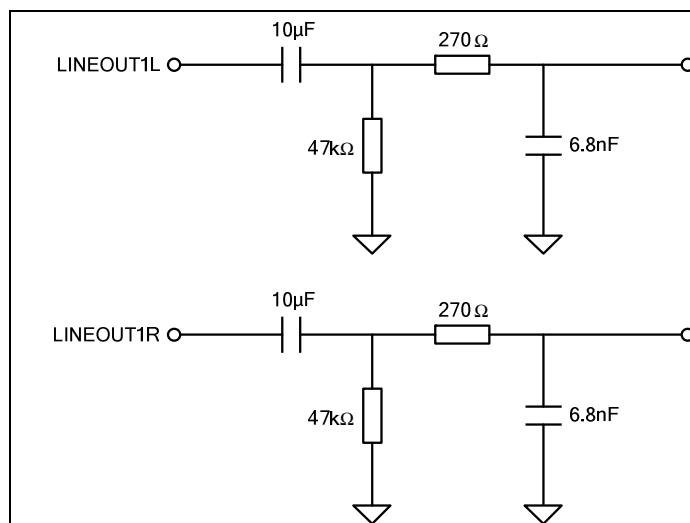
The following application notes, available from www.wolfsonmicro.com, may provide additional guidance for the use of the WM8595.

DEVICE PERFORMANCE:

WAN0129 – Decoupling and Layout Methodology for Wolfson DACs, ADCs and CODECs

WAN0144 – Using Wolfson Audio DACs and CODECs with Noisy Supplies

WAN0176 – AC Coupling Capacitor Selection

GENERAL:

WAN0108 – Moisture Sensitivity Classification and Plastic IC Packaging

WAN0109 – ESD Damage in Integrated Circuits: Causes and Prevention

WAN0158 – Lead-Free Solder Profiles for Lead-Free Components

PACKAGE DIMENSIONS

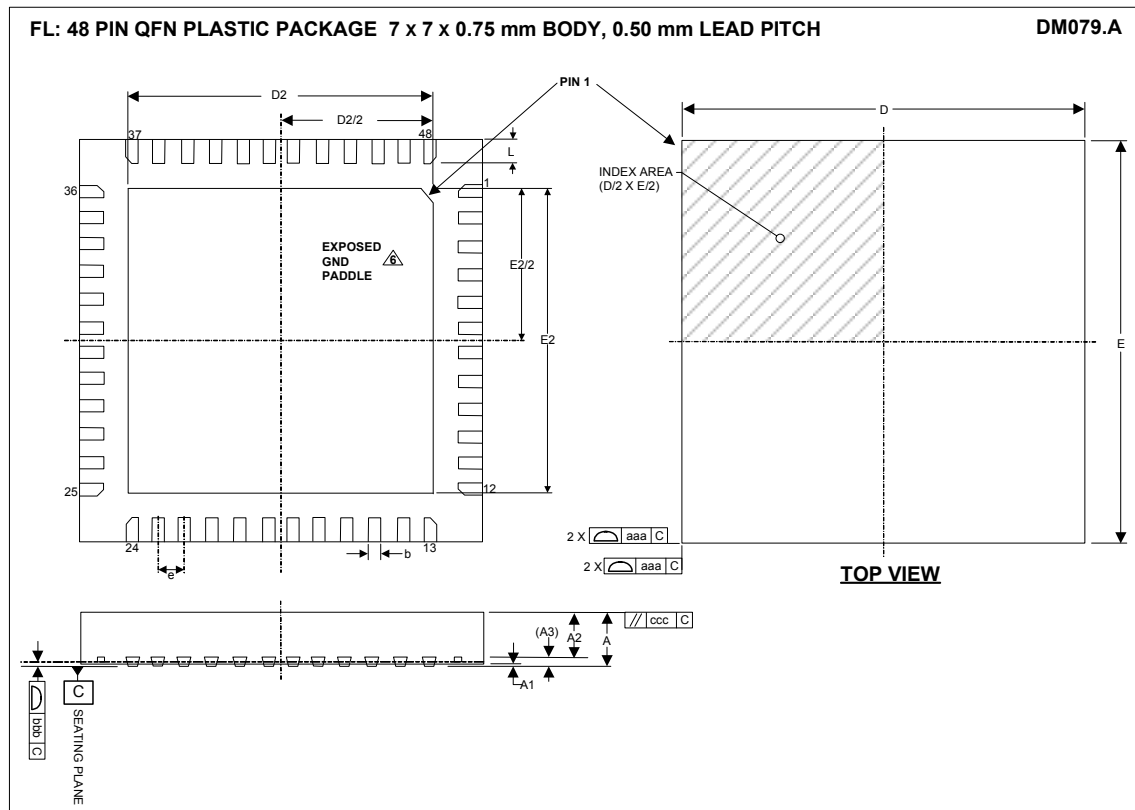

Symbols	Dimensions (mm)			NOTE
	MIN	NOM	MAX	
A	0.7	0.75	0.8	
A1	0	0.035	0.05	
A2	-	0.55	0.57	
A3		0.203 REF		
b	0.20	0.25	0.30	1
D		7.00 BSC		
D2	5.55	5.65	5.75	
E		7.00 BSC		
E2	5.55	5.65	5.75	
e		0.5 BSC		
L	0.35	0.4	0.45	
Tolerances of Form and Position				
aaa		0.10		
bbb		0.08		
ccc		0.10		
REF		JEDEC, MO-220		

- NOTES:
1. DIMENSION b APPLIED TO METALLIZED TERMINAL AND IS MEASURED BETWEEN 0.15 mm AND 0.30 mm FROM TERMINAL TIP.
 2. ALL DIMENSIONS ARE IN MILLIMETRES
 3. THE TERMINAL #1 IDENTIFIER AND TERMINAL NUMBERING CONVENTION SHALL CONFORM TO JESD 95-1 SPP-002.
 4. COPLANARITY APPLIES TO THE EXPOSED HEAT SINK SLUG AS WELL AS THE TERMINALS.
 5. THIS DRAWING IS SUBJECT TO CHANGE WITHOUT NOTICE.
 6. REFER TO APPLICATIONS NOTE WAN_0118 FOR FURTHER INFORMATION.

IMPORTANT NOTICE

Wolfson Microelectronics plc ("Wolfson") products and services are sold subject to Wolfson's terms and conditions of sale, delivery and payment supplied at the time of order acknowledgement.

Wolfson warrants performance of its products to the specifications in effect at the date of shipment. Wolfson reserves the right to make changes to its products and specifications or to discontinue any product or service without notice. Customers should therefore obtain the latest version of relevant information from Wolfson to verify that the information is current.

Testing and other quality control techniques are utilised to the extent Wolfson deems necessary to support its warranty. Specific testing of all parameters of each device is not necessarily performed unless required by law or regulation.

In order to minimise risks associated with customer applications, the customer must use adequate design and operating safeguards to minimise inherent or procedural hazards. Wolfson is not liable for applications assistance or customer product design. The customer is solely responsible for its selection and use of Wolfson products. Wolfson is not liable for such selection or use nor for use of any circuitry other than circuitry entirely embodied in a Wolfson product.

Wolfson's products are not intended for use in life support systems, appliances, nuclear systems or systems where malfunction can reasonably be expected to result in personal injury, death or severe property or environmental damage. Any use of products by the customer for such purposes is at the customer's own risk.

Wolfson does not grant any licence (express or implied) under any patent right, copyright, mask work right or other intellectual property right of Wolfson covering or relating to any combination, machine, or process in which its products or services might be or are used. Any provision or publication of any third party's products or services does not constitute Wolfson's approval, licence, warranty or endorsement thereof. Any third party trade marks contained in this document belong to the respective third party owner.

Reproduction of information from Wolfson datasheets is permissible only if reproduction is without alteration and is accompanied by all associated copyright, proprietary and other notices (including this notice) and conditions. Wolfson is not liable for any unauthorised alteration of such information or for any reliance placed thereon.

Any representations made, warranties given, and/or liabilities accepted by any person which differ from those contained in this datasheet or in Wolfson's standard terms and conditions of sale, delivery and payment are made, given and/or accepted at that person's own risk. Wolfson is not liable for any such representations, warranties or liabilities or for any reliance placed thereon by any person.

ADDRESS

Wolfson Microelectronics plc
Westfield House
26 Westfield Road
Edinburgh
EH11 2QB

Tel :: +44 (0)131 272 7000

Fax :: +44 (0)131 272 7001

Email :: sales@wolfsonmicro.com