

16 bit Seri-In/Parallel-Out Constant-Current LED Driver

General Description

The ME2604 is designed for LED displays and LED lighting applications. The ME2604 contains a 16-bit shift register and data latches, which convert serial input data into parallel output format. At the ME2604 output stage, 16 regulated current ports provide uniform and constant current for driving LEDs within a wide range of VF variations. Used in system design for LED display applications (e.g., LED panels), the ME2604 provides great flexibility and device performance. Users can adjust the output current from 3 mA to 45 mA through an external resistor, R_{ext} which gives flexibility in controlling the light intensity of LEDs. ME2604 is designed for up to 17 V at the output port. The high clock frequency, 25 MHz, also satisfies the system requirements of high-volume data transmission. The serial data is transferred into ME2604 via SDI, shifted in the shift register, and transferred out via SDO. LE can latch the serial data in the shift register to the output latch. OE enables the output drivers to sink current.

Pin Configurations

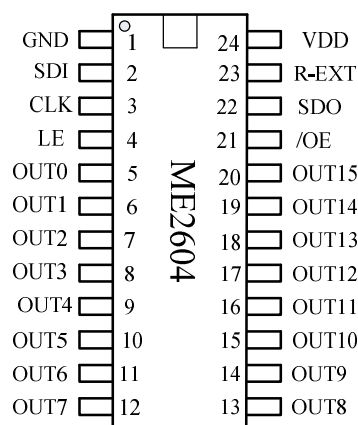

SSOP24; SSOP24-1.0; SOP24

Features

- 16 constant-current outputs rate at 17V
- Constant Output Current Invariant to Voltage
- Constant current range:
3-45mA@ $V_{DD}=5V$
3-30mA@ $V_{DD}=3.3V$
- Excellent Output Current Accuracy:
–Between Channels: $< \pm 2.5\%$ (Max)
–Between ICs: $< \pm 6\%$ (Max)
- Output Current Adjusted By External Resistor
- Fast Response of Output Current, OE (Min):50ns
- Staggered output delay: 10ns
- ESD Performance: 4-kV HBM
- 3.3-V to 5-V Supply Voltage
- Schmitt trigger input
- 25-MHz Clock Frequency

Typical Application

- LED Display Systems
- LED Traffic Signs
- Variable Message Signs

Product Name	Footprint	MARK
ME2604Q24A	SSOP24-0.635	2604A
ME2604Q24B	SSOP24-1.00	2604B
ME2604S24D	SOP24-1.27	2604D

Terminal Description

Pin	Name	Function
1	GND	Ground terminal.
2	SDI	Serial input of data shift register.
3	CLK	Clock input of shift register, data is sampled at the rising edge of CLK.
4	LE	Input terminal of data strobe. Data is latched when LE is low. And data on shift register goes through when LE is high.
5-20	OUT[0:15]	Open-drain, constant-current outputs.
21	OE/	Output enable signal. Output is enabled when OE/ is forced to low.
22	SDO	Output terminal of serial-data output to the SDI of next ME2604.
23	R-EXT	Used to connect an external resistor for setting up all output current.
24	VDD	Supply voltage terminal.

Absolute Maximum Ratings

Characteristic		Symbol	Rating	Unit
Supply Voltage		V_{DD}	0~7.0	V
Input Voltage		V_{IN}	-0.4~ $V_{DD}+0.4$	V
Output Current		I_{OUT}	+50	mA
Output Voltage		V_{DS}	-0.5~+20	V
Clock Frequency		F_{CLK}	25	MHz
Total GND Terminals Current		I_{GND}	+1000	mA
Power Dissipation	SOP24	P_D	1.92	W
	SSOP24		1.42	
	SSOP24-1.0		1.74	
Thermal Resistance	SOP24	$R_{TH(j-a)}$	65	°C/W
	SSOP24		88	
	SSOP24-1.0		72	
Operating Temperature		T_{OPR}	-40~85	°C
Storage Temperature		T_{STG}	-55~150	°C

Block Diagram

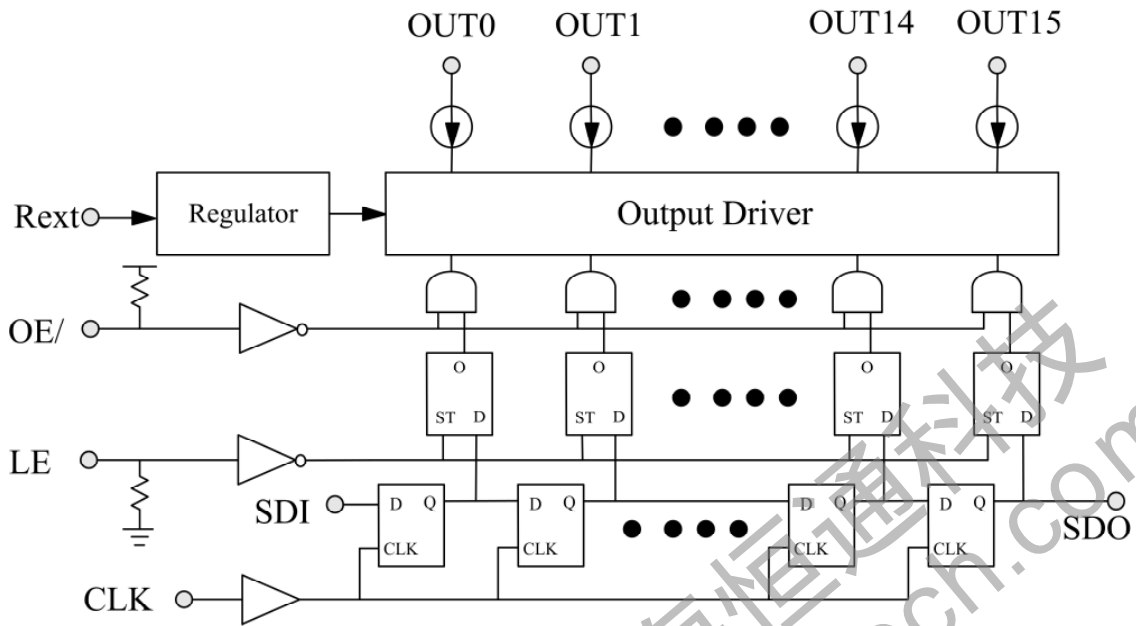

Timing Diagram

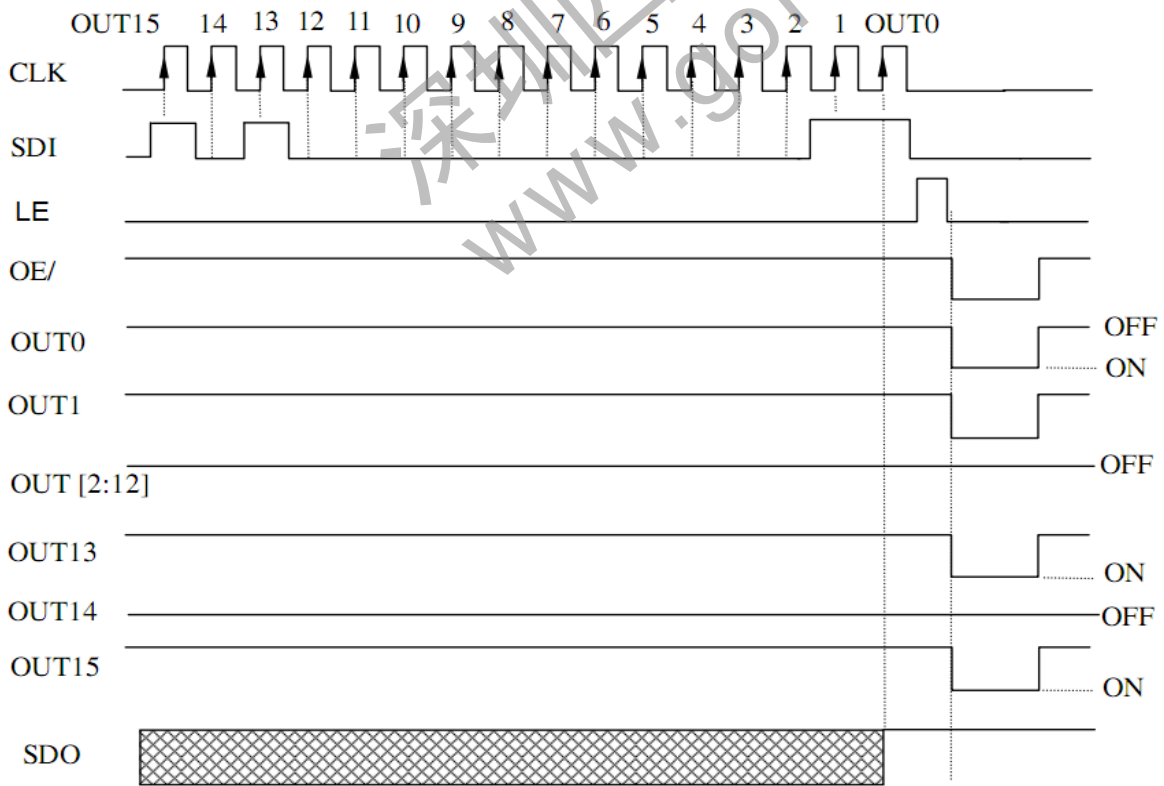

Equivalent Circuits of Inputs and Output

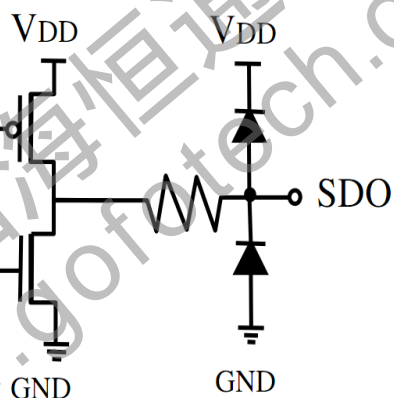
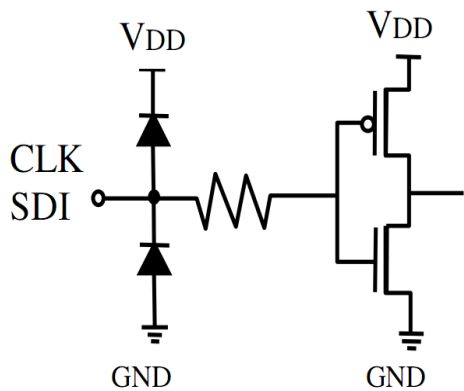
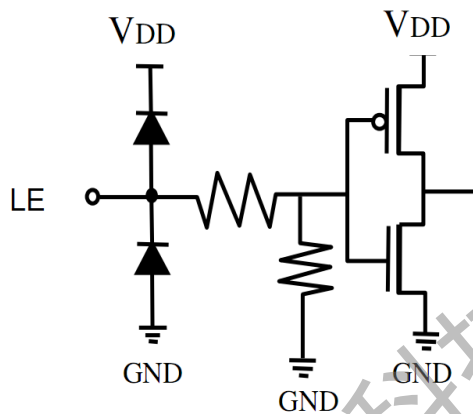
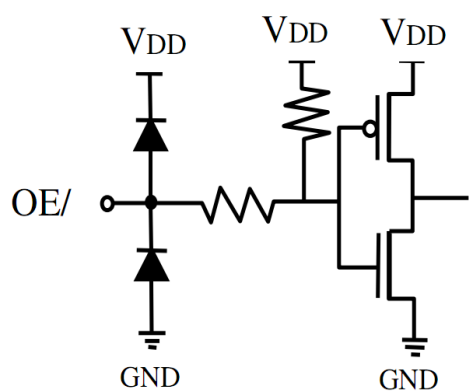

Electrical Characteristics

VDD=5.0V

Characteristic		Symbol	Condition		Min.	Typ.	Max.	Unit
Supply Voltage		V_{DD}	-		3.0	5.0	5.5	V
Output Voltage		V_{DS}	OUT0~OUT15		-	-	17	V
Output Current		I_{OUT}	$V_{DS}=1.0\sim 4.0$		3	-	45	mA
		I_{OH}	SDO		-	-	-1.0	mA
		I_{OL}	SDO		-	-	1.0	mA
Input Voltage	“H” level	V_{IH}	$T_a=-40\sim 80^{\circ}C$		$0.7*V_{DD}$	-	VDD	V
	“L” level	V_{IL}	$T_a=-40\sim 80^{\circ}C$		GND	-	$0.3*V_{DD}$	V
Output Leakage Current		I_{OUT}	$V_{DS}=17V$		-	-	0.5	uA
Output Voltage	SDO	V_{OL}	$I_{OL}=+1.0mA$		-	-	0.4	V
		V_{OH}	$I_{OH}=-1.0mA$		4.6	-	-	V
Output Current 1		I_{OUT1}	$V_{DS}=1.0V$	$R_{EXT}=1.24k\Omega$	-	15	-	mA
Current Skew		dI_{OUT1}	$V_{DS}=1.0V$ $R_{EXT}=1.24k\Omega$	$I_{OL}=15mA$	-	± 2	± 2.5	%
Output Current 2		I_{OUT1}	$V_{DS}=1.0V$	$R_{EXT}=470\Omega$	-	40	-	mA
Current Skew		dI_{OUT1}	$V_{DS}=1.0V$ $R_{EXT}=470\Omega$	$I_{OL}=40mA$	-	± 2	± 2.5	%
Output Current vs. Output Voltage Regulation		$\%/dV_{DS}$	V_{DS} within 1.0V and 3.0V		-	± 0.1	-	%/V
Output Current vs. Supply Voltage Regulation		$\%/dV_{DD}$	V_{DD} within 4.5 and 5.5V		-	-	± 1.0	%/V
Pull-up Resistor		$R_{IN(up)}$	/OE		250	500	800	K Ω
Pull-down Resistor		$R_{IN(down)}$	LE		250	500	800	K Ω
Supply Current	“OFF”	$I_{DD(off)1}$	$R_{EXT}=\text{open}, \text{OUT0}\sim \text{OUT15}=\text{OFF}$		-	2	2.5	mA
		$I_{DD(off)2}$	$R_{EXT}=1.26K\Omega, \text{OUT0}\sim \text{OUT15}=\text{OFF}$		-	4.8	6	
		$I_{DD(off)3}$	$R_{EXT}=475\Omega, \text{OUT0}\sim \text{OUT15}=\text{OFF}$		-	6.7	8	
	“ON”	$I_{DD(on)1}$	$R_{EXT}=1.26K\Omega, \text{OUT0}\sim \text{OUT15}=\text{ON}$		-	5.7	8	
		$I_{DD(on)2}$	$R_{EXT}=475\Omega, \text{OUT0}\sim \text{OUT15}=\text{ON}$		-	7.6	10	

VDD=3.3V

Characteristic		Symbol	Condition		Min.	Typ.	Max.	Unit
Supply Voltage		V_{DD}	-		3.0	3.3	4.5	V
Output Voltage		V_{DS}	OUT0~OUT15		-	-	17	V
Output Current		I_{OUT}	$V_{DS}=1.0\sim 4.0$		3	-	45	mA
		I_{OH}	SDO		-	-	-1.0	mA
		I_{OL}	SDO		-	-	1.0	mA
Input Voltage	“H” level	V_{IH}	$T_a=-40\sim 80^{\circ}C$		$0.7*V_{DD}$	-	VDD	V
	“L” level	V_{IL}	$T_a=-40\sim 80^{\circ}C$		GND	-	$0.3*V_{DD}$	V
Output Leakage Current		I_{OUT}	$V_{DS}=17V$		-	-	0.5	uA
Output Voltage	SDO	V_{OL}	$I_{OL}=+1.0mA$		-	-	0.4	V
		V_{OH}	$I_{OH}=-1.0mA$		2.9	-	-	V
Output Current 1		I_{OUT1}	$V_{DS}=1.0V$	$R_{EXT}=6.2k\Omega$	-	3	-	mA
Current Skew		dI_{OUT1}	$V_{DS}=1.0V$ $R_{EXT}=6.2k\Omega$	$I_{OL}=3mA$	-	± 2	± 2.5	%
Output Current 2		I_{OUT1}	$V_{DS}=1.0V$	$R_{EXT}=744\Omega$	-	25	-	mA
Current Skew		dI_{OUT1}	$V_{DS}=1.0V$ $R_{EXT}=744\Omega$	$I_{OL}=25mA$	-	± 2	± 2.5	%
Output Current vs. Output Voltage Regulation		$\%/dV_{DS}$	V_{DS} within 1.0V and 3.0V		-	± 0.1	-	%/V
Output Current vs. Supply Voltage Regulation		$\%/dV_{DD}$	V_{DD} within 3.0 and 3.6V		-	-	± 1.0	%/V
Pull-up Resistor		$R_{IN(up)}$	/OE		300	500	700	K Ω
Pull-down Resistor		$R_{IN(down)}$	LE		300	500	700	K Ω
Supply Current	“OFF”	$I_{DD(off)1}$	$R_{EXT}=\text{open}, \text{OUT0}\sim \text{OUT15}=\text{OFF}$		-	1.7	2.2	mA
		$I_{DD(off)2}$	$R_{EXT}=1.26K\Omega, \text{OUT0}\sim \text{OUT15}=\text{OFF}$		-	4.5	6	
		$I_{DD(off)3}$	$R_{EXT}=760\Omega, \text{OUT0}\sim \text{OUT15}=\text{OFF}$		-	6.5	8	
	“ON”	$I_{DD(on)1}$	$R_{EXT}=1.26K\Omega, \text{OUT0}\sim \text{OUT15}=\text{ON}$		-	5.5	8	
		$I_{DD(on)2}$	$R_{EXT}=760\Omega, \text{OUT0}\sim \text{OUT15}=\text{ON}$		-	7.0	10	

Switching Characteristics (VDD=5.0V)

Characteristic		Symbol	Condition	Min.	Typ.	Max.	Unit
Propagation Delay Time ("L" to "H")	CLK-OUT2n	t_{pLH1}	$V_{DD}=5.0V$ $V_{DS}=1.0V$ $V_{IH}=V_{DD}$ $R_{EXT}=1K\Omega$ $V_L=4.5V$ $R_L=160\Omega$ $C_L=10pF$	-	50	70	ns
	CLK-OUT2n+1			-	35	55	ns
	LE-OUT2n	t_{pLH2}		-	50	70	ns
	LE-OUT2n+1			-	35	55	ns
	/OE-OUT2n	t_{pLH3}		-	50	70	ns
	/OE-OUT2n+1			-	35	55	ns
	CLK-SDO	t_{pLH}		-	20	40	ns
Propagation Delay Time ("H" to "L")	CLK-OUT2n	t_{pHL1}		-	90	110	ns
	CLK-OUT2n+1			-	75	95	ns
	LE-OUT2n	t_{pHL2}		-	90	110	ns
	LE-OUT2n+1			-	75	95	ns
	/OE-OUT2n	t_{pHL3}		-	90	110	ns
	/OE-OUT2n+1			-	75	95	ns
	CLK-SDO	t_{pHL}		-	20	40	ns
Pulse Width	CLK	$t_{w(CLK)}$	20	-	-	ns	
	LE	$t_{w(L)}$	20	-	-	ns	
	/OE	$t_{w(OE)}$	50	70	-	ns	
Hold Time for LE		$t_{h(L)}$		30	-	-	ns
Setup Time for LE		$t_{su(L)}$		5	-	-	ns
Hold Time for SDI		$t_{h(D)}$		5	-	-	ns
Setup Time for SDI		$t_{su(D)}$		3	-	-	ns
Maximum CLK Rise Time		t_r		-	-	500	ns
Maximum CLK Fall Time		t_f		-	-	500	ns
Rise Time of SDO		$t_{r,SDO}$		-	10	-	ns
Fall Time of SDI		$t_{f,SDO}$		-	10	-	ns
Output Rise Time of Iout		t_{or}		-	40	-	ns
Output Fall Time of Iout		t_{of}		-	55	-	ns

Switching Characteristics (VDD=3.3V)

Characteristic		Symbol	Condition	Min.	Typ.	Max.	Unit
Propagation Delay Time ("L" to "H")	CLK-OUT2n	t_{pLH1}	$V_{DD}=3.3V$ $V_{DS}=1.0V$ $V_{IH}=V_{DD}$ $R_{EXT}=1K\Omega$ $V_L=3.0V$ $R_L=100\Omega$ $C_L=10pF$	-	50	70	ns
	CLK-OUT2n+1			-	35	55	ns
	LE-OUT2n	t_{pLH2}		-	50	70	ns
	LE-OUT2n+1			-	35	55	ns
	/OE-OUT2n	t_{pLH3}		-	50	70	ns
	/OE-OUT2n+1			-	35	55	ns
	CLK-SDO	t_{pLH}		-	20	40	ns
Propagation Delay Time ("L" to "H")	CLK-OUT2n	t_{pHL1}		-	115	135	ns
	CLK-OUT2n+1			-	100	120	ns
	LE-OUT2n	t_{pHL2}		-	115	135	ns
	LE-OUT2n+1			-	100	120	ns
	/OE-OUT2n	t_{pHL3}		-	105	125	ns
	/OE-OUT2n+1			-	90	110	ns
	CLK-SDO	t_{pHL}		-	20	40	ns
Pulse Width	CLK	$t_{w(CLK)}$	20	-	-	ns	
	LE	$t_{w(L)}$	20	-	-	ns	
	/OE	$t_{w(OE)}$	70	90	-	ns	
Hold Time for LE		$t_{h(L)}$		30	-	-	ns
Setup Time for LE		$t_{su(L)}$		5	-	-	ns
Hold Time for SDI		$t_{h(D)}$		5	-	-	ns
Setup Time for SDI		$t_{su(D)}$		3	-	-	ns
Maximum CLK Rise Time		t_r		-	-	500	ns
Maximum CLK Fall Time		t_f		-	-	500	ns
Rise Time of SDO		$t_{r,SDO}$		-	10	-	ns
Fall Time of SDI		$t_{f,SDO}$		-	10	-	ns
Output Rise Time of Iout		t_{or}		-	40	-	ns
Output Fall Time of Iout		t_{of}		-	60	-	ns

Timing Waveform

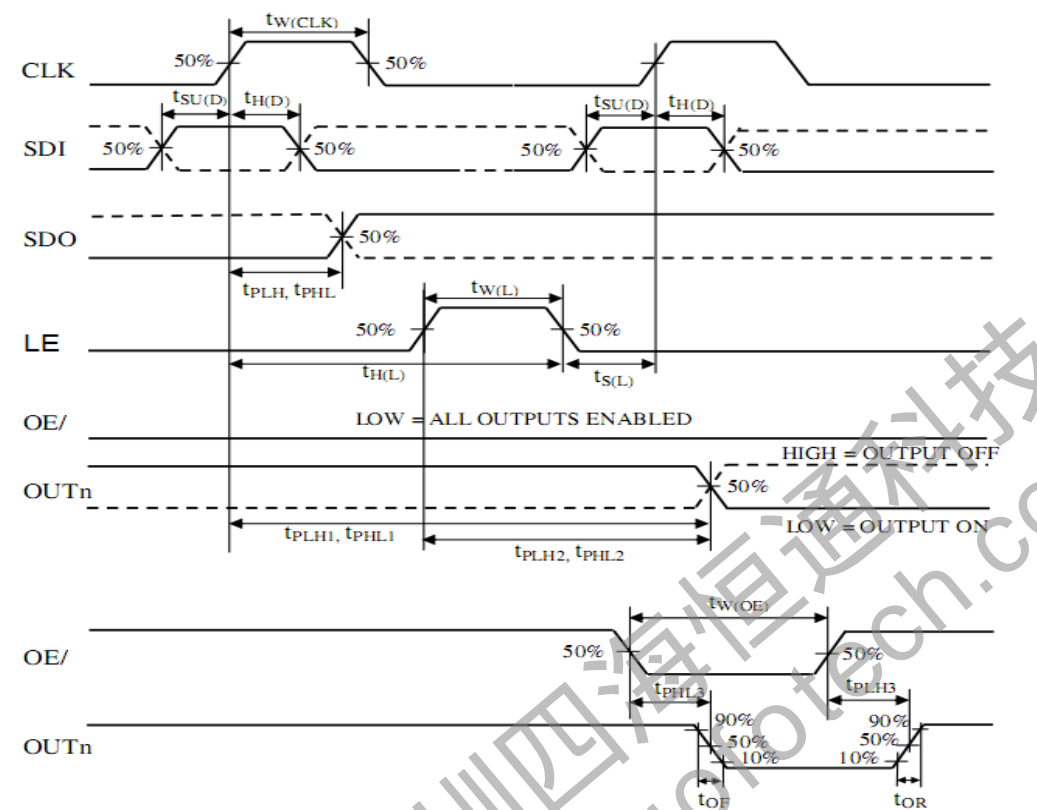

Adjusting Output Current

All ME2604's output current (I_{OUT}) are set by one external resistor at pin Rext. The output current can be calculated from the equation:

$$I_{out} = 1.24V \times (1/R_{ext}) \times 15$$

The relationship between I_{OUT} and resistance R_{EXT} is shown as the following figure.

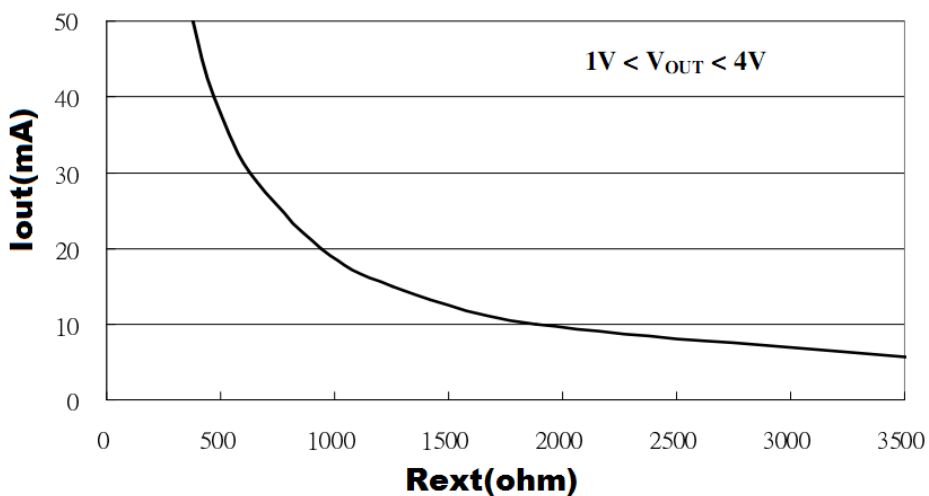

Output Characteristics

The current characteristic of output stage is flat. The output current can be kept constant regardless of the variations of LED forward voltage when $V_{OUT} > 1.0V$.

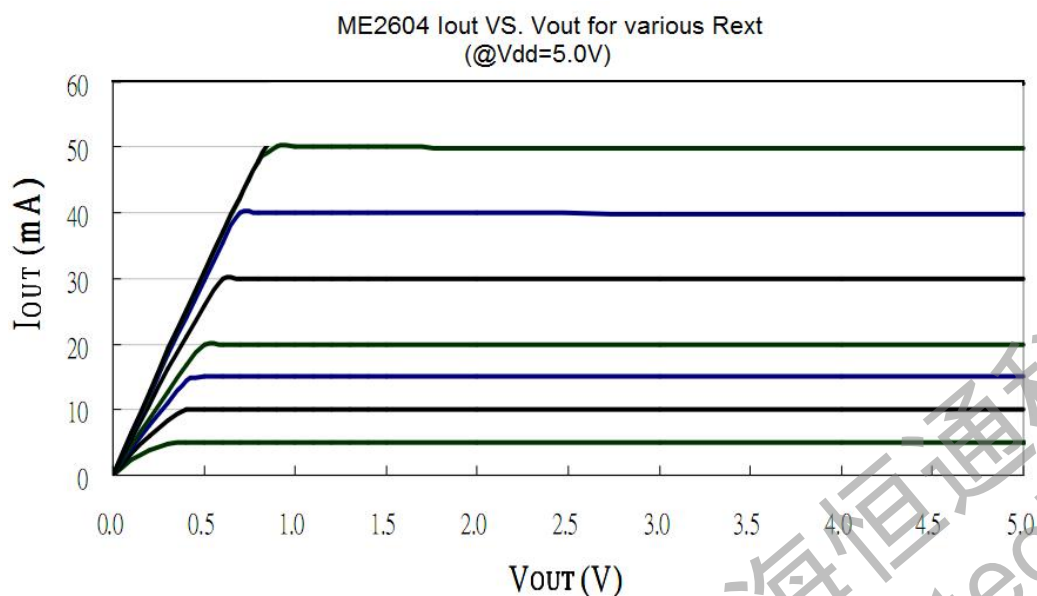

Power Dissipation

The power dissipation (P_D) of a semiconductor chip is limited by its package and ambient temperature. The maximum allowable power dissipation $P_{D(max)}$ is determined by :

$$P_{D(max)} = (T_{j(max)} - T_a) / R_{th(j-a)}$$

where $T_{j(max)}$: maximum chip junction temperature, usually considered as 150°C

T_a : ambient temperature

$R_{th(j-a)}$: thermal resistance of the package.

The relationship between $P_{D(max)}$ and T_a is shown as the below figure:

Packaging Information

SOP24

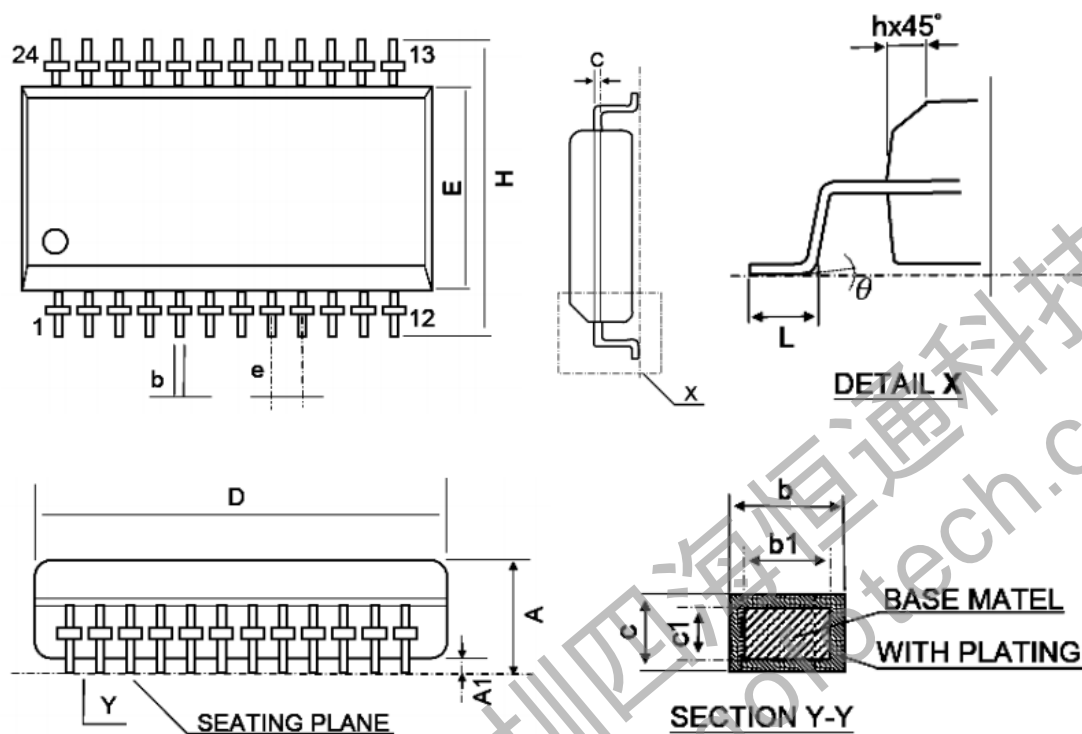

SYMBOL	DIMENSION (mm)			DIMENSION (mil)		
	MIN	NOM	MAX	MIN	NOM	MAX
A	2.36	2.54	2.64	93	100	104
A1	0.10	0.20	0.30	4	8	12
b	0.35	0.406	0.48	14	16	19
b1	0.35		0.46	14		18
c	0.23	0.254	0.31	9	10	12
c1	0.23		0.29	9		11
D	15.20	15.29	15.60	598	602	614
E	7.40	7.50	7.60	291	295	299
e	1.27 BSC			50 BSC		
H	10.00	10.31	10.65	394	406	419
h	0.25	0.66	0.75	10	26	30
L	0.51	0.76	1.02	20	30	40
Y			0.075			3
θ	0°		8°	0°		8°

SSOP24

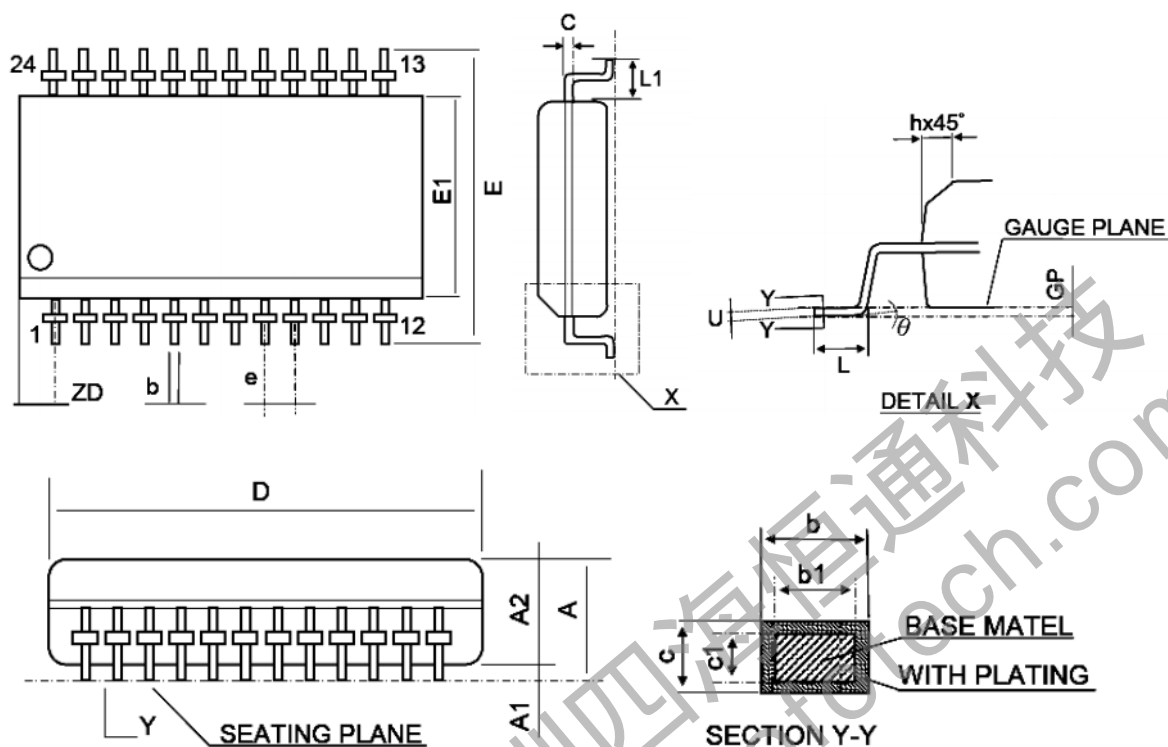

SYMBOL	DIMENSION (mm)			DIMENSION (mil)		
	MIN	NOM	MAX	MIN	NOM	MAX
A	1.35	1.60	1.75	53	63	69
A1	0.10	0.15	0.25	4	6	10
A2			1.50			59
b	0.20		0.30	8		12
b1	0.20	0.254	0.28	8	10	11
c	0.18		0.25	7		10
c1	0.18	0.203	0.23	7	8	9
D	8.56	8.66	8.74	337	341	344
E	5.80	6.00	6.20	228	236	244
E1	3.80	3.90	4.00	150	154	157
e	0.635 BSC			25 BSC		
h	0.25	0.42	0.50	10	17	20
L	0.40	0.635	1.27	16	25	50
L1	1.00	1.05	1.10	39	41	43
ZD	0.838 REF			33 REF		
Y			0.10			4
θ	0°		8°	0°		8°

SSOP24-1.0

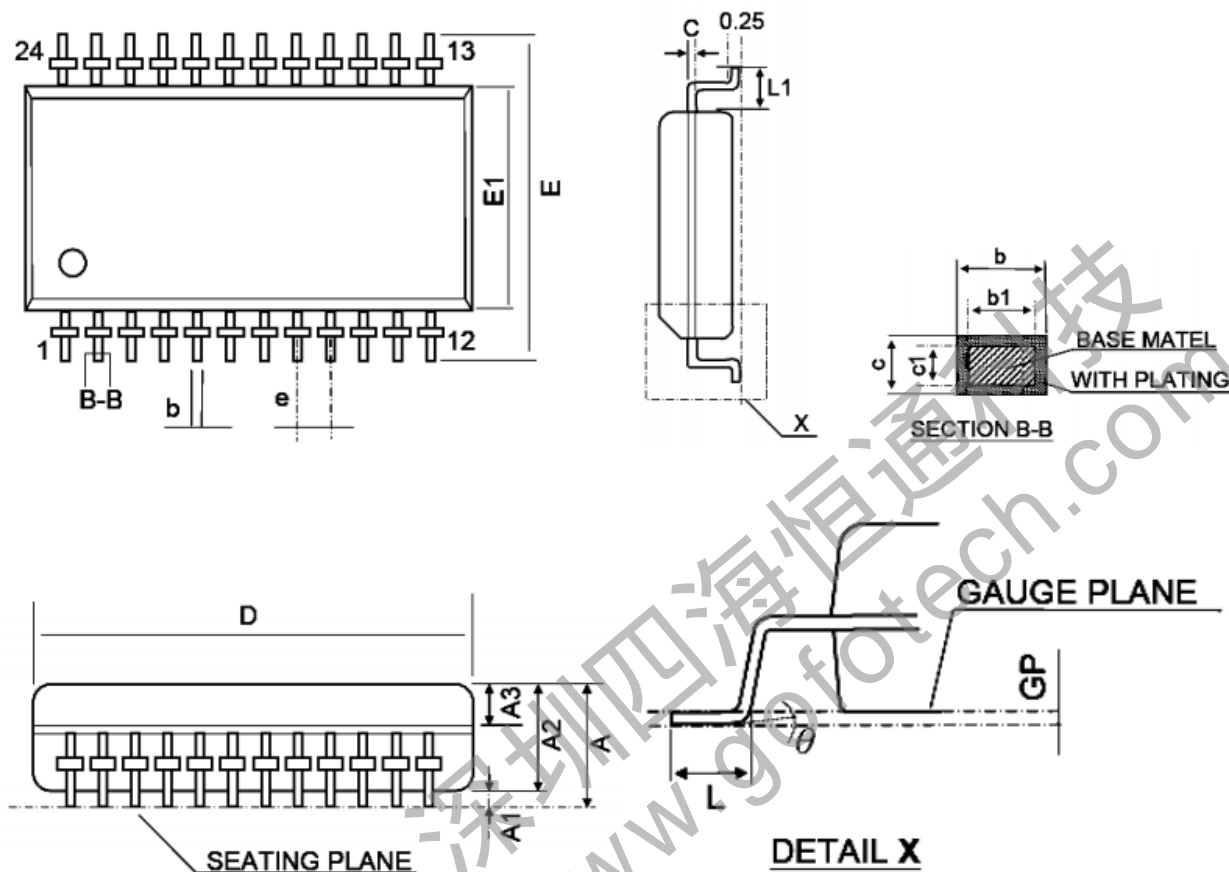

SYMBOL	DIMENSION (mm)			DIMENSION (mil)		
	MIN	NOM	MAX	MIN	NOM	MAX
A	-	-	2.20	-	-	87
A1	0.10	0.20	0.30	4	8	12
A2	1.60	1.80	2.00	63	71	79
A3	0.62	0.82	0.92	24	32	36
b	0.39	-	0.47	15	-	19
b1	0.38	0.40	0.43	15	16	17
c	0.15	-	0.20	6	-	8
c1	0.14	0.15	0.16	5.5	6	6.5
D	12.80	13.00	13.20	504	512	520
E	7.70	7.90	8.10	303	311	319
E1	5.80	6.00	6.20	228	236	244
e	1.00 BSC			39 BSC		
L	0.35	0.45	0.55	14	18	22
L1	0.95 BSC			37 BSC		
θ	0°	-	8°	0°	-	8°

- The information described herein is subject to change without notice.
- Nanjing Micro One Electronics Inc is not responsible for any problems caused by circuits or diagrams described herein whose related industrial properties, patents, or other rights belong to third parties. The application circuit examples explain typical applications of the products, and do not guarantee the success of any specific mass-production design.
- Use of the information described herein for other purposes and/or reproduction or copying without the express permission of Nanjing Micro One Electronics Inc is strictly prohibited.
- The products described herein cannot be used as part of any device or equipment affecting the human body, such as exercise equipment, medical equipment, security systems, gas equipment, or any apparatus installed in airplanes and other vehicles, without prior written permission of Nanjing Micro One Electronics Inc.
- Although Nanjing Micro One Electronics Inc exerts the greatest possible effort to ensure high quality and reliability, the failure or malfunction of semiconductor products may occur. The user of these products should therefore give thorough consideration to safety design, including redundancy, fire-prevention measures, and malfunction prevention, to prevent any accidents, fires, or community damage that may ensue.