

Features

- Full bluetooth cost effective solution for telematic.
- Bluetooth v2.0 + EDR specification
- HFP (1.5)/HS
- PBAP
- SPP
- DUN
- A2DP
- AVRCP (1.3)
- Multiprofile support
- High quality audio
- 64MIPS kalimba DSP co-processor.
- cVc generation 4, for echo and noise reduction.
- Integrated regulator
- Best-in-class Bluetooth radio with 7dBm transmit power and -90dBm receive sensitivity.
- 68-lead 8 x 8 x 0.9mm, 0.4mm pitch QFN package.
- RoadTunes Rom solution is extracted from CSR RoadTunes software solution which can also be ordered for all CSR BlueCore5-Multimedia flash based products.

General Description

Based on BlueCore[®]5-Multimedia ROM QFN, the RoadTunes ROM QFN Automotive integrates a Bluetooth radio, baseband, DSP, high-quality audio codec, SMPS, LDOs and a battery charger for minimal BOM, component count and PCB area.

RoadTunes ROM QFN Automotive is the most integrated SW Rom chip on the market with 6 profiles at low cost and very low development cycle.

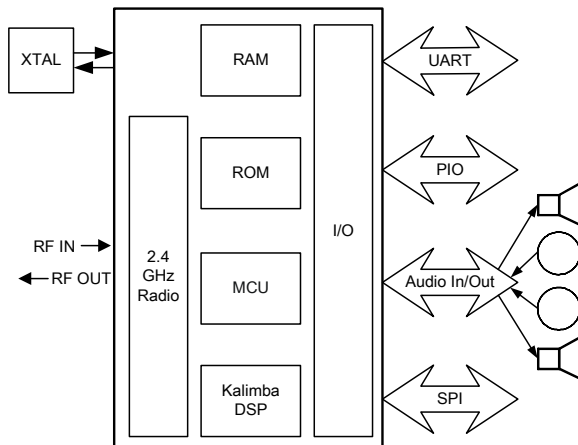

RoadTunes[®] ROM QFN Automotive

RoadTunes ROM Solution Single-chip Bluetooth[®] v2.0 + EDR System

Advance Information

BC57K687

Issue 2

Applications

RoadTunes is the new bluetooth host based software solution from CSR. By integrating a simple software interface on their processor, CSR customers have access to a multitude of tested Bluetooth profiles: A2DP (source and sink), AVRCP (target and controller), HFP, SPP and PBAP. This software interface enables commands to control the chip via UART and requires very low additional MIPS on their main processor. This new software contains an automotive grade echo cancellation and noise reduction solution in the form of the CSR's new cVc Gen 4 algorithm.

Document History

Revision	Date	Change Reason
1	23 JAN 09	Original publication of this document
2	26 JAN 09	Administrative updates If you have any comments about this document, email comments@csr.com giving the number, title and section with your feedback.

深圳市诚至微科技有限公司
电话：0755-83328582
手机：13510662515
<http://www.czwtech.com>

Status Information

The status of this Data Sheet is **Advance Information**.

CSR Product Data Sheets progress according to the following format:

Advance Information

Information for designers concerning CSR product in development. All values specified are the target values of the design. Minimum and maximum values specified are only given as guidance to the final specification limits and must not be considered as the final values.

All detailed specifications including pinouts and electrical specifications may be changed by CSR without notice.

Pre-production Information

Pinout and mechanical dimension specifications finalised. All values specified are the target values of the design. Minimum and maximum values specified are only given as guidance to the final specification limits and must not be considered as the final values.

All electrical specifications may be changed by CSR without notice.

Production Information

Final Data Sheet including the guaranteed minimum and maximum limits for the electrical specifications.

Production Data Sheets supersede all previous document versions.

ESD Precautions

RoadTunes ROM QFN Automotive is classified as a JEDEC22-A114 class 2 product. Apply ESD static handling precautions during manufacturing.

Life Support Policy and Use in Safety-critical Applications

CSR's products are not authorised for use in life-support or safety-critical applications. Use in such applications is done at the sole discretion of the customer. CSR will not warrant the use of its devices in such applications.

CSR Green Semiconductor Products and RoHS Compliance

RoadTunes ROM QFN Automotive devices meet the requirements of Directive 2002/95/EC of the European Parliament and of the Council on the Restriction of Hazardous Substance (RoHS).

RoadTunes ROM QFN Automotive devices are also free from halogenated or antimony trioxide-based flame retardants and other hazardous chemicals. For more information, see CSR's *Environmental Compliance Statement for CSR Green Semiconductor Products*.

Trademarks, Patents and Licences

Unless otherwise stated, words and logos marked with [™] or [®] are trademarks registered or owned by CSR plc or its affiliates. Bluetooth[®] and the Bluetooth logos are trademarks owned by Bluetooth SIG, Inc. and licensed to CSR. Other products, services and names used in this document may have been trademarked by their respective owners.

The publication of this information does not imply that any license is granted under any patent or other rights owned by CSR plc.

CSR reserves the right to make technical changes to its products as part of its development programme.

While every care has been taken to ensure the accuracy of the contents of this document, CSR cannot accept responsibility for any errors.

CSR's products are not authorised for use in life-support or safety-critical applications.

Refer to www.csrsupport.com for compliance and conformance to standards information.

Contents

1	Device Details	8
2	Functional Block Diagram	9
3	Package Information	10
3.1	Pinout Diagram	10
3.2	Device Terminal Functions	11
3.3	Package Dimensions	15
3.4	PCB Design and Assembly Considerations	16
3.5	Typical Solder Reflow Profile	16
4	Bluetooth Modem	17
4.1	RF Ports	17
4.1.1	RF_N and RF_P	17
4.2	RF Receiver	17
4.2.1	Low Noise Amplifier	17
4.2.2	RSSI Analogue to Digital Converter	17
4.3	RF Transmitter	18
4.3.1	IQ Modulator	18
4.3.2	Power Amplifier	18
4.4	Bluetooth Radio Synthesiser	18
4.5	Baseband	18
4.5.1	Burst Mode Controller	18
4.5.2	Physical Layer Hardware Engine	18
4.6	Basic Rate Modem	18
4.7	Enhanced Data Rate Modem	18
4.7.1	Enhanced Data Rate $\pi/4$ DQPSK	19
4.7.2	Enhanced Data Rate 8DPSK	20
5	Clock Generation	22
5.1	Clock Architecture	22
5.2	Input Frequencies and PS Key Settings	22
5.3	Crystal Oscillator (XTAL_IN, XTAL_OUT)	22
5.3.1	Load Capacitance	23
5.3.2	Frequency Trim	23
5.3.3	Transconductance Driver Model	24
5.3.4	Negative Resistance Model	24
5.3.5	Crystal PS Key Settings	25
5.4	External Reference Clock	25
5.4.1	Input (XTAL_IN)	25
5.4.2	XTAL_IN Impedance in External Mode	25
5.4.3	Clock Start-up Delay	26
5.4.4	Clock Timing Accuracy	26
6	Bluetooth Stack Microcontroller	27
6.1	Programmable I/O Ports, PIO and AIO	27
7	Kalimba DSP	28
8	Memory Interface and Management	29
8.1	Memory Management Unit	29
8.2	System RAM	29
8.3	Kalimba DSP RAM	29
8.4	Internal ROM	29
9	Serial Interfaces	30
9.1	UART Interface	30
9.1.1	UART Configuration While Reset is Active	31

9.2	Serial Peripheral Interface	32
9.2.1	Instruction Cycle	32
9.2.2	Writing to the Device	32
9.2.3	Reading from the Device	32
9.2.4	Multi-slave Operation	33
10	Audio Interface	34
10.1	Audio Input and Output	34
10.2	Audio Codec Interface	35
10.2.1	Audio Codec Block Diagram	35
10.2.2	ADC	35
10.2.3	ADC Sample Rate	35
10.2.4	ADC Digital Gain	35
10.2.5	ADC Analogue Gain	36
10.2.6	DAC	37
10.2.7	DAC Sample Rate Selection	37
10.2.8	DAC Digital Gain	37
10.2.9	DAC Analogue Gain	39
10.2.10	Microphone Input	40
10.2.11	Line Input	42
10.2.12	Output Stage	43
10.2.13	Mono Operation	43
10.2.14	Side Tone	44
10.2.15	Integrated Digital Filter	44
10.3	PCM Interface	45
11	Power Control and Regulation	46
11.1	Power Sequencing	46
11.2	External Voltage Source	46
11.3	Switch-mode Regulator	47
11.4	Low-voltage Linear Regulator	47
11.5	Low-voltage Audio Linear Regulator	47
11.6	Voltage Regulator Enable Pins	48
11.7	Battery Charger	48
11.8	Reset, RST#	48
11.8.1	Digital Pin States on Reset	49
11.8.2	Status after Reset	49
12	Example Application Schematic	50
13	Electrical Characteristics	51
13.1	Absolute Maximum Ratings	51
13.2	Recommended Operating Conditions	51
13.3	Input/Output Terminal Characteristics	52
13.3.1	Low-voltage Linear Audio Regulator	52
13.3.2	Switch-mode Regulator	53
13.3.3	Battery Charger	54
13.3.4	Reset	55
13.3.5	Regulator Enable	55
13.3.6	Digital Terminals	56
13.3.7	Mono Codec: Analogue to Digital Converter	57
13.3.8	Stereo Codec: Digital to Analogue Converter	58
13.3.9	Clocks	58
13.3.10	Auxiliary ADC	59
14	CSR Green Semiconductor Products and RoHS Compliance	60
14.1	RoHS Statement	60
14.1.1	List of Restricted Materials	60
15	RoadTunes ROM QFN Automotive Software Stack	61

15.1	Standalone RoadTunes ROM QFN Automotive and Kalimba DSP Applications	61
15.2	RoadTunes ROM Solution Development Kit, DEV-RR-CT-SDK-01A	62
15.3	RoadTunes ROM QFN Automotive Software, BC57K687A07-IQF	62
16	Tape and Reel Information	63
16.1	Tape Orientation	63
16.2	Tape Dimensions	63
16.3	Reel Information	64
16.4	Moisture Sensitivity Level	64
17	Ordering Information	65
17.1	RoadTunes ROM Development Kit Ordering Information	65
18	Document References	66
	Terms and Definitions	67

List of Figures

Figure 2.1	RoadTunes ROM QFN Automotive Functional Block Diagram	9
Figure 3.1	RoadTunes ROM QFN Automotive Device Pinout	10
Figure 3.2	RoadTunes ROM QFN Automotive 68 Lead QFN Package Dimensions	15
Figure 4.1	Simplified Circuit RF_N and RF_P	17
Figure 4.2	BDR and EDR Packet Structure	19
Figure 4.3	$\pi/4$ DQPSK Constellation Pattern	20
Figure 4.4	8DPSK Constellation Pattern	21
Figure 5.1	Clock Architecture	22
Figure 5.2	Crystal Driver Circuit	22
Figure 5.3	Crystal Equivalent Circuit	23
Figure 5.4	TCXO Clock Accuracy	26
Figure 7.1	Kalimba DSP Interface to Internal Functions	28
Figure 9.1	Universal Asynchronous Receiver	30
Figure 9.2	Break Signal	31
Figure 9.3	SPI Write Operation	32
Figure 9.4	SPI Read Operation	33
Figure 10.1	RoadTunes ROM QFN Automotive Audio Interface	34
Figure 10.2	Codec Audio Input and Output Stages	35
Figure 10.3	ADC Analogue Amplifier Block Diagram	37
Figure 10.4	Microphone Biasing (Single Channel Shown)	40
Figure 10.5	Differential Input (Single Channel Shown)	43
Figure 10.6	Single-Ended Input (Single Channel Shown)	43
Figure 10.7	Speaker Output (Single Channel Shown)	43
Figure 11.1	Voltage Regulator Configuration	46
Figure 12.1	RoadTunes ROM QFN Automotive Example Application Schematic	50
Figure 15.1	Standalone Application: RoadTunes ROM Solution	61
Figure 16.1	RoadTunes ROM QFN Automotive Tape Orientation	63
Figure 16.2	Reel Dimensions	64

List of Tables

Table 4.1	Data Rate Schemes	19
Table 4.2	2 Bits Determine Phase Shift Between Consecutive Symbols	20
Table 4.3	3 Bits Determine Phase Shift Between Consecutive Symbols	21
Table 5.1	Crystal Specification	23
Table 5.2	External Clock Specifications	25
Table 9.1	Possible UART Settings	30
Table 9.2	Standard Baud Rates	31

Table 9.3	Instruction Cycle for an SPI Transaction	32
Table 10.1	ADC Digital Gain Rate Selection	36
Table 10.2	DAC Digital Gain Rate Selection	37
Table 10.3	DAC Analogue Gain Rate Selection	39
Table 10.4	Voltage Output Steps	41
Table 10.5	Current Output Steps	42
Table 11.1	RoadTunes ROM QFN Automotive Voltage Regulator Enable Pins	48
Table 11.2	RoadTunes ROM QFN Automotive Digital Pin States on Reset	49

List of Equations

Equation 5.1	Load Capacitance	23
Equation 5.2	Trim Capacitance	23
Equation 5.3	Frequency Trim	24
Equation 5.4	Pullability	24
Equation 5.5	Transconductance Required for Oscillation	24
Equation 5.6	Equivalent Negative Resistance	25
Equation 9.1	Baud Rate	31
Equation 10.1	IIR Filter Transfer Function, $H(z)$	45
Equation 10.2	IIR Filter plus DC Blocking Transfer Function, $H_{DC}(z)$	45

深圳市誠立創科技有限公司
电话：0755-83328582
手机：13510662515
<http://www.czwtech.com>

1 Device Details

Radio

- Common TX/RX terminal simplifies external matching; eliminates external antenna switch
- BIST minimises production test time
- Bluetooth v2.0 + EDR specification compliant

Transmitter

- 7dBm RF transmit power with level control from on-chip 6-bit DAC over a dynamic range >30dB
- Class 2 and Class 3 support without the need for an external power amplifier or TX/RX switch

Receiver

- Receiver sensitivity of -90dBm
- Integrated channel filters
- Digital demodulator for improved sensitivity and co-channel rejection
- Real-time digitised RSSI available on HCI interface
- Fast AGC for enhanced dynamic range

Synthesiser

- Fully integrated synthesiser requires no external VCO, varactor diode, resonator or loop filter
- Compatible with crystals 16MHz to 26MHz or an external clock 12MHz to 52MHz

Physical Interfaces

- Synchronous serial interface for system debugging
- UART interface

Auxiliary Features

- Crystal oscillator with built-in digital trimming
- Power management includes digital shutdown and wake-up commands with an integrated low-power oscillator for ultra-low power Park/Sniff/Hold mode
- Clock request output to control external clock
- On-chip regulators: 1.5V output from 1.8V to 2.7V input
- On-chip high-efficiency switched-mode regulator: 1.8V output from 2.7V to 4.4V input
- Power-on-reset cell detects low-supply voltage
- 10-bit ADC available to applications
- On-chip 150mA charger for lithium ion/polymer batteries

Kalimba DSP

- Very low-power Kalimba DSP co-processor, 64MIPS, 24-bit fixed point core
- Support for SBC and MP3 codec for improved audio quality.
- Single-cycle MAC; 24 x 24-bit multiply and 56-bit accumulator
- 32-bit instruction word, dual 24-bit data memory
- 6K x 32-bit program RAM, 8K x 24-bit + 8K x 24-bit data RAM
- 64 x 32-bit program memory cache when executing from ROM

Audio Codec

- 16-bit internal codec
- DAC for stereo audio
- ADC dual channel mono voice band audio
- Integrated amplifiers for driving 16Ω speakers; no need for external components
- Support for single-ended speaker termination and line output
- Integrated low-noise microphone bias

Baseband and Software

- Internal ROM
- 48KB of internal RAM, allows full-speed data transfer, mixed voice/data and full piconet support
- Logic for FEC, HEC, access code correlation, CRC, demodulation, encryption bit stream generation, whitening and transmit pulse shaping
- Transcoders for A-law, μ -law and linear voice from host and A-law, μ -law and CVSD voice over air
- Configurable Roadtunes Rom CSR software with HFP, A2DP, AVRCP, SPP, DUN, Bluetooth v2.0 + EDR and DSP based single-microphone cVc echo and noise reduction is included in the RoadTunes ROM QFN Automotive
- A new high-performance dual-microphone noise reduction is available in RoadTunes ROM QFN Automotive as a licensed option for an extra 20dB of noise suppression, order code BCSW-CVC-HS-2M-R3

Package Option

- QFN 68-lead, 8 x 8 x 0.9mm, 0.4mm pitch

2 Functional Block Diagram

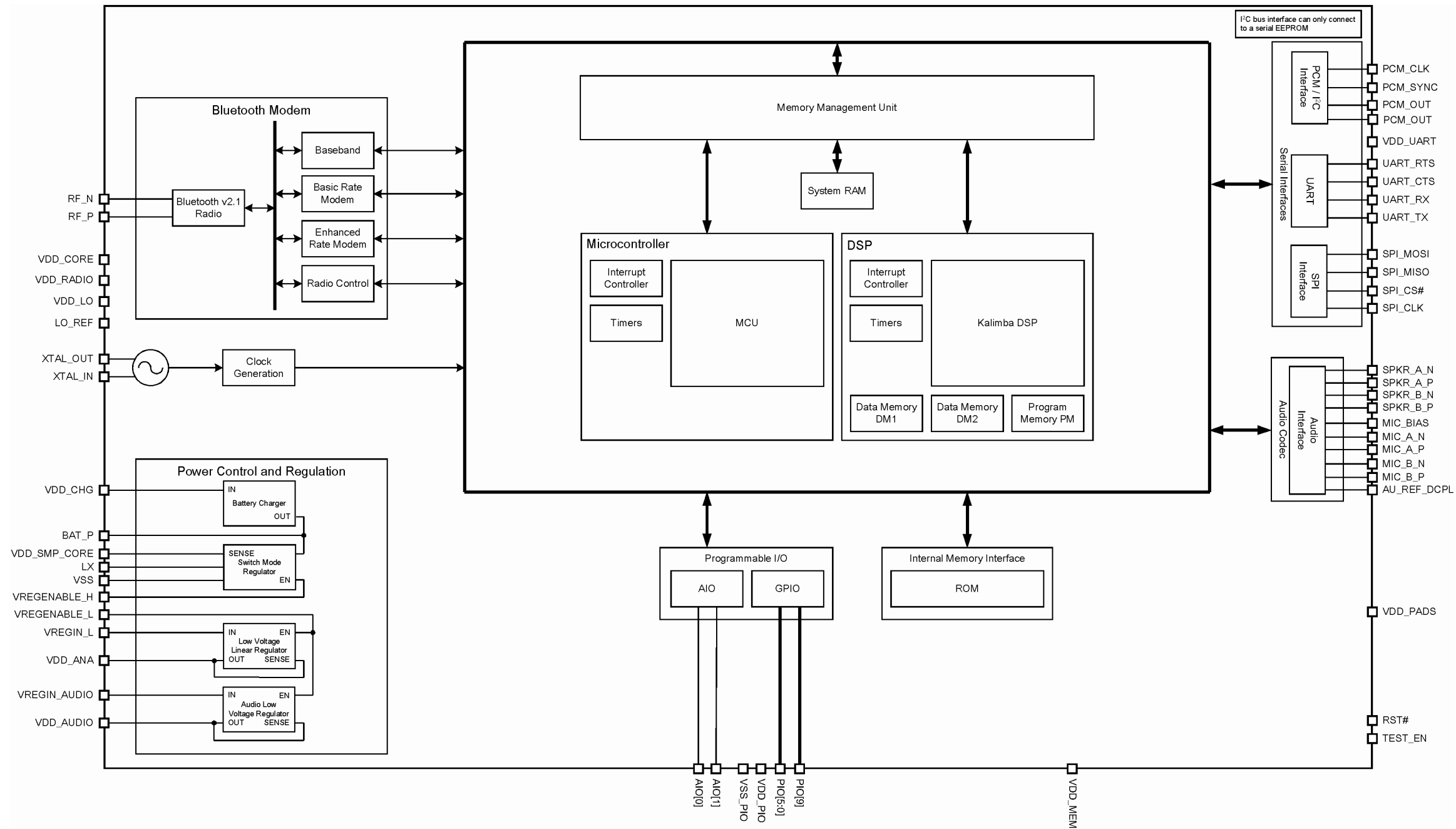

Figure 2.1: RoadTunes ROM QFN Automotive Functional Block Diagram

3 Package Information

3.1 Pinout Diagram



Figure 3.1: RoadTunes ROM QFN Automotive Device Pinout

3.2 Device Terminal Functions

Bluetooth Radio	Lead	Pad Type	Supply Domain	Description
RF_N	65	RF	VDD_RADIO	Transmitter output/switched receiver
RF_P	64	RF		Complement of RF_N

Synthesiser and Oscillator	Lead	Pad Type	Supply Domain	Description
XTAL_IN	3	Analogue	VDD_ANA	For crystal or external clock input
XTAL_OUT	4			Drive for crystal
LO_REF	5			Reference voltage to decouple the synthesiser

SPI Interface	Lead	Pad Type	Supply Domain	Description
SPI_MOSI	30	Input, with weak internal pull-down	VDD_PADS	SPI data input
SPI_CS#	32	Bidirectional with weak internal pull-down		Chip select for SPI, active low
SPI_CLK	31	Bidirectional with weak internal pull-down		SPI clock
SPI_MISO	33	Bidirectional with weak internal pull-down		SPI data output

UART Interface	Lead	Pad Type	Supply Domain	Description
UART_TX	9	Output, tri-state, with weak internal pull-down	VDD_UART	UART data output, active high
UART_RX	10	Bidirectional with weak internal pull-down		UART data input, active high
UART_RTS	12	Bidirectional CMOS output, tri-state, with weak internal pull-up		UART request to send active low
UART_CTS	11	CMOS input with weak internal pull-down		UART clear to send active low

PCM Interface	Lead	Pad Type	Supply Domain	Description
PCM_OUT	29	CMOS output, Tri-state with weak internal pull-down	VDD_PADS	Synchronous data output
PCM_IN	26	CMOS input with weak internal pull-down		Synchronous data input
PCM_SYNC	28	Bi-directional with weak internal pull-down		Synchronous data sync
PCM_CLK	27	Bi-directional with weak internal pull-down		Synchronous data clock

PIO Port	Lead	Pad Type	Supply Domain	Description
PIO[13]	18	Bidirectional with programmable strength internal pull-up/down	VDD_PADS	Programmable input/output line
PIO[12]	17			
PIO[9]	14			
PIO[8]	19			
PIO[7]	20			
PIO[6]	21			
PIO[5]	22			
PIO[4]	23			
PIO[3]	58	Bidirectional with programmable strength internal pull-up/down	VDD_PIO	Programmable input/output line
PIO[2]	59			
PIO[1]	60			
PIO[0]	61			
AIO[1]	6	Bidirectional	VDD_ANA	Programmable input/output line
AIO[0]	7			

Audio	Lead	Pad Type	Supply Domain	Description
SPKR_A_N	56	Analogue	VDD_AUDIO	Speaker output, negative, channel A
SPKR_A_P	57	Analogue	VDD_AUDIO	Speaker output, positive, channel A
SPKR_B_N	53	Analogue	VDD_AUDIO	Speaker output, negative, channel B
SPKR_B_P	54	Analogue	VDD_AUDIO	Speaker output, positive, channel B
MIC_A_N	52	Analogue	VDD_AUDIO	Microphone input, negative, channel A
MIC_A_P	51	Analogue	VDD_AUDIO	Microphone input, positive, channel A
MIC_B_N	50	Analogue	VDD_AUDIO	Microphone input, negative, channel B
MIC_B_P	48	Analogue	VDD_AUDIO	Microphone input, positive, channel B
MIC_BIAS	45	Analogue	VDD_AUDIO, BAT_P	Microphone bias
AU_REF_DCPL	55	Analogue	VDD_AUDIO	Decoupling of audio reference, for high-quality audio

Test and Debug	Lead	Pad Type	Supply Domain	Description
RST#	24	Input with weak internal pull-up	VDD_PADS	Reset if low. Input debounced so must be low for >5ms to cause a reset
TEST_EN	25	Input with strong internal pull-down		For test purposes only. Leave unconnected

Power Supplies Control	Lead	Description
VREGENABLE_L	68	Low-voltage linear regulator and low-voltage audio linear regulator enable, active high
VREGIN_L	1	Input to internal low-voltage regulator
VREGENABLE_H	35	Switch-mode regulator enable, active high
VREGIN_AUDIO	46	Input to internal audio low-voltage linear regulator
VDD_AUDIO	47	Positive supply for audio
LX	37	Switch-mode regulator output
VDD_ANA	2	Positive supply output for analogue circuitry and 1.5V regulated output, from internal low-voltage regulator
VDD_PIO	62	Positive supply for digital input/output ports PIO[3:0]
VDD_PADS	15	Positive supply for all other digital input/output ports including PIO[9:4]
VDD_CORE	16, 34	Positive supply for internal digital circuitry
VDD_RADIO	63, 66	Positive supply for RF circuitry
VDD_UART	13	Positive supply for UART ports
VDD_LO	67	Positive supply for local oscillator circuitry
BAT_P	38	Lithium ion/polymer battery positive terminal. Battery charger output and input to switch-mode regulator
VDD_CHG	39	Lithium ion/polymer battery charger input
VDD_SMP_CORE	36	Positive supply for switch-mode control circuitry
VSS	Exposed Pad	Ground connections

Unconnected Leads (N/Cs)	Description
8, 40, 41, 42, 43, 44, 49	Leave unconnected

3.3 Package Dimensions

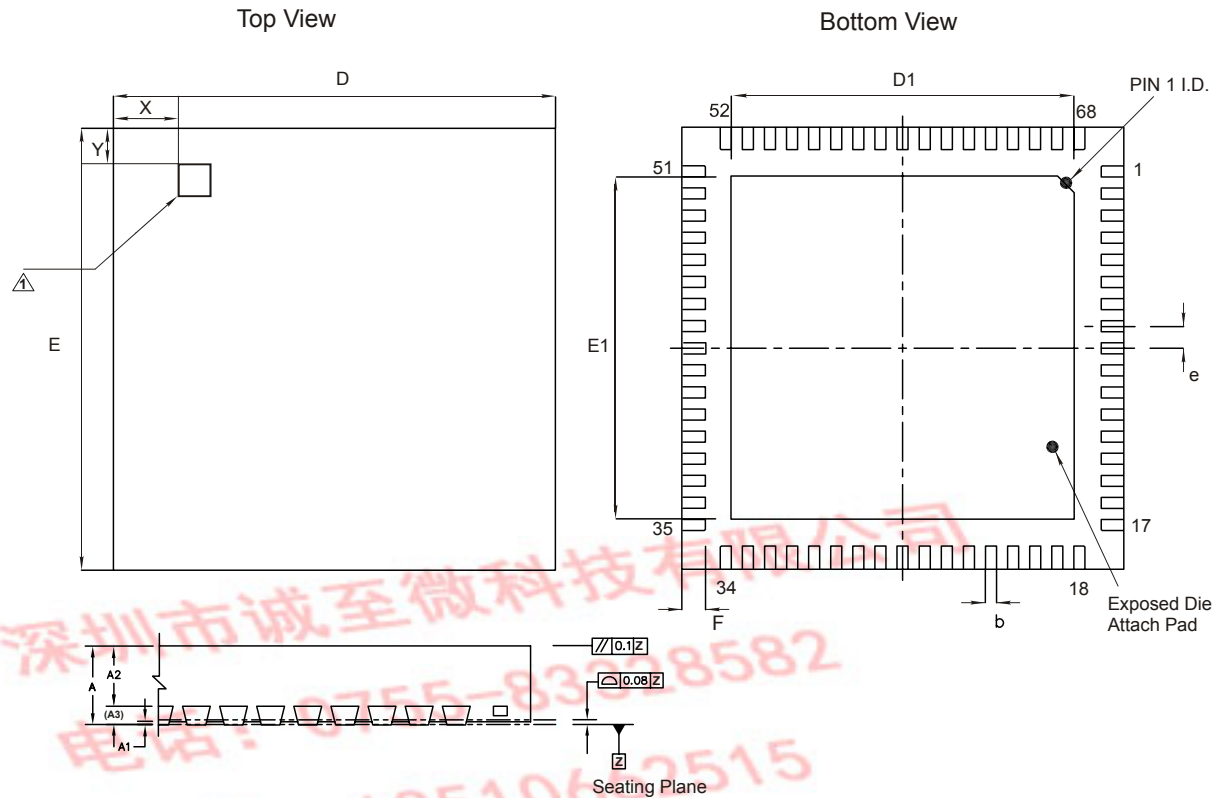

Description	68-lead Quad Flat No-lead Package			
Size	8 x 8 x 0.9mm			
Pitch	0.4mm			
Dimension	Minimum	Typical	Maximum	Notes
A	0.80	0.85	0.90	⚠ Top-side polarity mark. The dimensions of the square polarity mark are 0.75 x 0.75mm.
A1	0.00	0.035	0.05	
A2	-	0.65	0.67	Coplanarity applies to leads, corner leads and die attach pad.
A3	-	0.203	-	
b	0.15	0.20	0.25	
D	7.90	8.00	8.05	
E	7.90	8.00	8.05	
e	-	0.40	-	
D1	6.10	6.20	6.30	
E1	6.10	6.20	6.30	
F	0.35	0.40	0.45	
X	-	1.00	-	
Y	-	0.85	-	
JEDEC	MO-220			
Unit	mm			

Figure 3.2: RoadTunes ROM QFN Automotive 68 Lead QFN Package Dimensions

3.4 PCB Design and Assembly Considerations

This section lists recommendations to achieve maximum board-level reliability of the 8 x 8 x 0.9mm QFN 68-lead package:

- NSMD lands (lands smaller than the solder mask aperture) are preferred, because of the greater accuracy of the metal definition process compared to the solder mask process. With solder mask defined pads, the overlap of the solder mask on the land creates a step in the solder at the land interface, which can cause stress concentration and act as a point for crack initiation.
- PCB land width should be 0.2mm and PCB land length should be 0.55mm to achieve maximum reliability.
- Solder paste must be used during the assembly process.

3.5 Typical Solder Reflow Profile

See *Typical Solder Reflow Profile for Lead-free Devices* for information.

深圳市诚至微科技有限公司
电话: 0755-83328582
手机: 13510662515
<http://www.czwtech.com>

4 Bluetooth Modem

4.1 RF Ports

4.1.1 RF_N and RF_P

RF_N and RF_P form a complementary balanced pair and are available for both transmit and receive. On transmit their outputs are combined using an external balun into the single-ended output required for the antenna. Similarly, on receive their input signals are combined internally.

Both terminals present similar complex impedances that may require matching networks between them and the balun. Viewed from the chip, the outputs can each be modelled as an ideal current source in parallel with a lossy capacitor. An equivalent series inductance can represent the package parasitics.

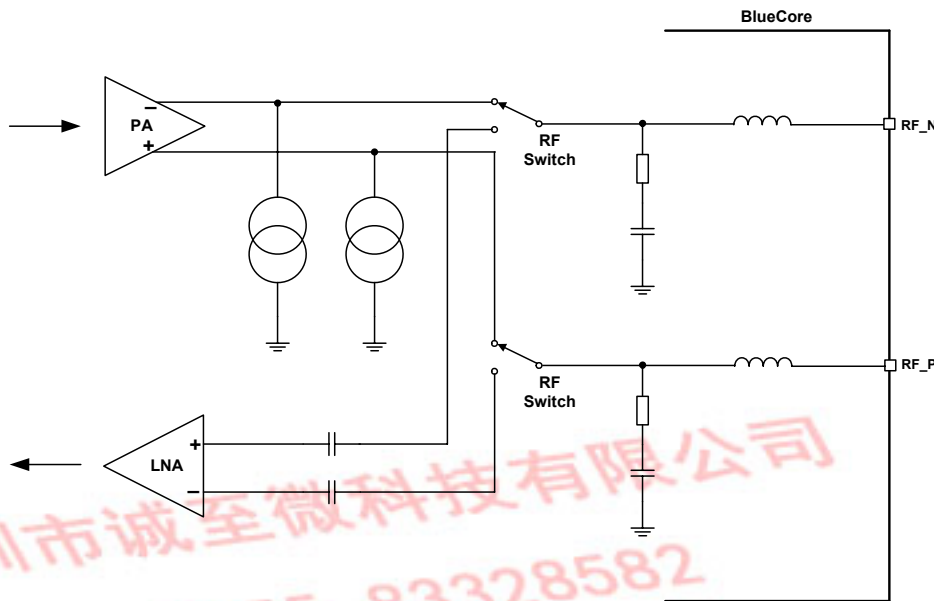

Figure 4.1: Simplified Circuit RF_N and RF_P

RF_N and RF_P require an external DC bias. The DC level must be set at VDD_RADIO.

4.2 RF Receiver

The receiver features a near-zero IF architecture that allows the channel filters to be integrated onto the die. Sufficient out-of-band blocking specification at the LNA input allows the receiver to be used in close proximity to GSM and W-CDMA cellular phone transmitters without being desensitised. The use of a digital FSK discriminator means that no discriminator tank is needed and its excellent performance in the presence of noise allows RoadTunes ROM QFN Automotive to exceed the Bluetooth requirements for co-channel and adjacent channel rejection.

For EDR, the demodulator contains an ADC which digitises the IF received signal. This information is then passed to the EDR modem.

4.2.1 Low Noise Amplifier

The LNA operates in differential mode and takes its input from the shared RF port.

4.2.2 RSSI Analogue to Digital Converter

The ADC implements fast AGC. The ADC samples the RSSI voltage on a slot-by-slot basis. The front-end LNA gain is changed according to the measured RSSI value, keeping the first mixer input signal within a limited range. This improves the dynamic range of the receiver, improving performance in interference limited environments.

4.3 RF Transmitter

4.3.1 IQ Modulator

The transmitter features a direct IQ modulator to minimise frequency drift during a transmit timeslot, which results in a controlled modulation index. Digital baseband transmit circuitry provides the required spectral shaping.

4.3.2 Power Amplifier

The internal PA has a maximum output power that allows RoadTunes ROM QFN Automotive to be used in Class 2 and Class 3 radios without an external RF PA.

4.4 Bluetooth Radio Synthesiser

The Bluetooth radio synthesiser is fully integrated onto the die with no requirement for an external VCO screening can, varactor tuning diodes, LC resonators or loop filter. The synthesiser is guaranteed to lock in sufficient time across the guaranteed temperature range to meet the Bluetooth v2.0 + EDR specification.

4.5 Baseband

4.5.1 Burst Mode Controller

During transmission the BMC constructs a packet from header information previously loaded into memory-mapped registers by the software and payload data/voice taken from the appropriate ring buffer in the RAM. During reception, the BMC stores the packet header in memory-mapped registers and the payload data in the appropriate ring buffer in RAM. This architecture minimises the intervention required by the processor during transmission and reception.

4.5.2 Physical Layer Hardware Engine

Dedicated logic performs the following:

- Forward error correction
- Header error control
- Cyclic redundancy check
- Encryption
- Data whitening
- Access code correlation
- Audio transcoding

Firmware performs the following voice data translations and operations:

- A-law/ μ -law/linear voice data (from host)
- A-law/ μ -law/CVSD (over the air)
- Voice interpolation for lost packets
- Rate mismatch correction

The hardware supports all optional and mandatory features of Bluetooth v2.0 + EDR specification including AFH and eSCO.

4.6 Basic Rate Modem

The basic rate modem satisfies the basic data rate requirements of the Bluetooth v2.0 + EDR specification. The basic rate was the standard data rate available on the Bluetooth v1.2 specification and below, it is based on GFSK modulation scheme.

The inclusion of the basic rate modem allows RoadTunes ROM QFN Automotive compatibility with earlier Bluetooth products.

The basic rate modem uses the RF ports, receiver, transmitter and synthesiser, alongside the baseband components described in Section 4.5.

4.7 Enhanced Data Rate Modem

The EDR modem satisfies the requirements of the Bluetooth v2.0 + EDR specification. EDR has been introduced to provide 2x and 3x data rates with minimal disruption to higher layers of the Bluetooth stack. RoadTunes ROM QFN Automotive supports both the basic and enhanced data rates and is compliant with the Bluetooth v2.0 + EDR specification.

At the baseband level, EDR utilises both the same 1.6kHz slot rate and the 1MHz symbol rate as defined for the basic data rate. EDR differs in that each symbol in the payload portion of a packet represents 2 or 3 bits. This is achieved using two new distinct modulation schemes. Table 4.1 and Figure 4.2 summarise these. Link Establishment and management are unchanged and still use GFSK for both the header and payload portions of these packets.

The enhanced data rate modems uses the RF Ports, Receiver, Transmitter and Synthesiser, with the baseband components described in Section 4.5.

Data Rate Scheme	Bits Per Symbol	Modulation
Basic Rate	1	GFSK
EDR	2	$\pi/4$ DQPSK
EDR	3	8DPSK (optional)

Table 4.1: Data Rate Schemes

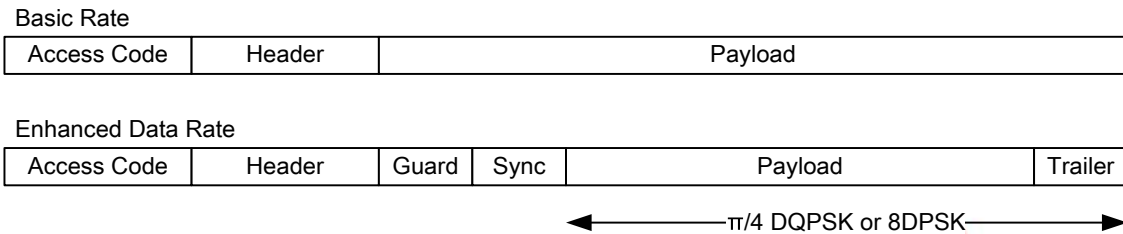

Figure 4.2: BDR and EDR Packet Structure

4.7.1 Enhanced Data Rate $\pi/4$ DQPSK

The 2x data rate for EDR uses a $\pi/4$ -DQPSK. Each symbol represents 2 bits of information. Figure 4.3 shows the constellation. It has two planes, each having four points. Although it seems there are eight possible phase states, the encoding ensures that the trajectory of the modulation between symbols is restricted to the four states in the other plane.

For a given starting point, each phase change between symbols is restricted to $3\pi/4$, $\pi/4$, $-\pi/4$ or $-3\pi/4$ radians (135° , 45° , -45° or -135°). For example, the arrows shown in Figure 4.3 represent trajectory to the four possible states in the other plane. Table 4.2 shows the phase shift encoding of symbols.

There are two main advantages in using $\pi/4$ DQPSK modulation:

- The scheme avoids the crossing of the origin (a π or $-\pi$ phase shift) and therefore minimises amplitude variations in the envelope of the transmitted signal. This in turn allows the RF power amplifiers of the transmitter to be operated closer to their compression point without introducing spectral distortions. Consequently, the DC to RF efficiency is maximised.
- The differential encoding also allows for the demodulation without the knowledge of an absolute value for the phase of the RF carrier.

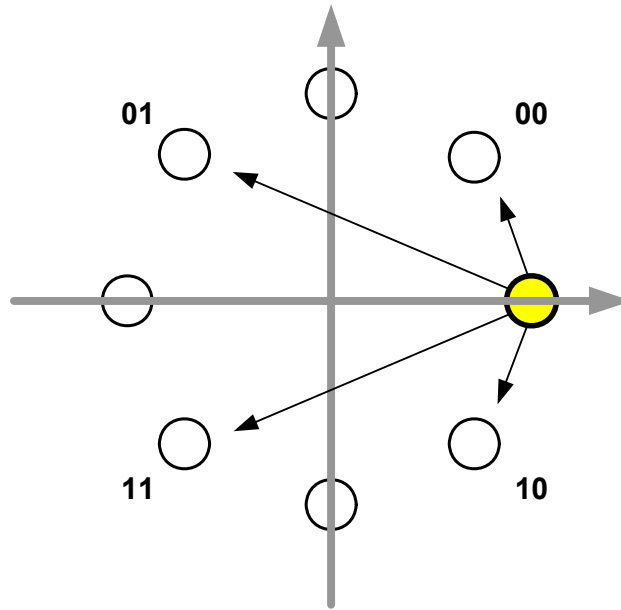
 Figure 4.3: $\pi/4$ DQPSK Constellation Pattern

Bit Pattern	Phase Shift
00	$\pi/4$
01	$3\pi/4$
11	$-3\pi/4$
10	$-\pi/4$

Table 4.2: 2 Bits Determine Phase Shift Between Consecutive Symbols

4.7.2 Enhanced Data Rate 8DPSK

The 3x data rate modulation uses 8DPSK. Each symbol in the payload portion of the packet represents 3 baseband bits. Although it seems the 8DPSK is similar to $\pi/4$ DQPSK, the differential phase shifts between symbols are now permissible between any of the eight possible phase states. This reduces the separation between adjacent symbols on the constellation to $\pi/4$ (45°) and thereby reduces the noise and interference immunity of the modulation scheme. Nevertheless, because each symbol now represents 3 baseband bits, the actual throughput of the data is 3x when compared with the basic rate packet.

Figure 4.4 shows the 8DPSK constellation and Table 4.3 shows the phase encoding.

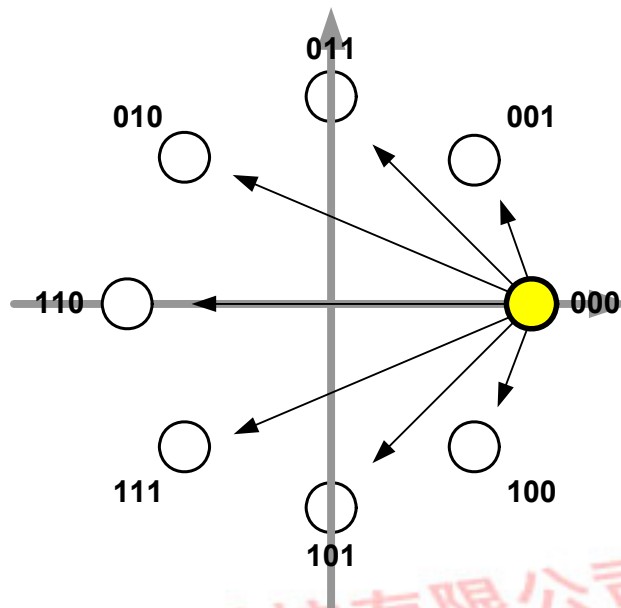

Figure 4.4: 8DPSK Constellation Pattern

Bit Pattern	Phase Shift
000	0
001	$\pi/4$
011	$\pi/2$
010	$3\pi/4$
110	π
111	$-3\pi/4$
101	$-\pi/2$
100	$-\pi/4$

Table 4.3: 3 Bits Determine Phase Shift Between Consecutive Symbols

5 Clock Generation

RoadTunes ROM QFN Automotive requires a Bluetooth reference clock frequency of 12MHz to 52MHz from either an externally connected crystal or from an external TCXO source.

All RoadTunes ROM QFN Automotive internal digital clocks are generated using a phase locked loop, which is locked to the frequency of either the external 12MHz to 52MHz reference clock source or an internally generated watchdog clock frequency of 1kHz.

The Bluetooth operation determines the use of the watchdog clock in low-power modes.

5.1 Clock Architecture

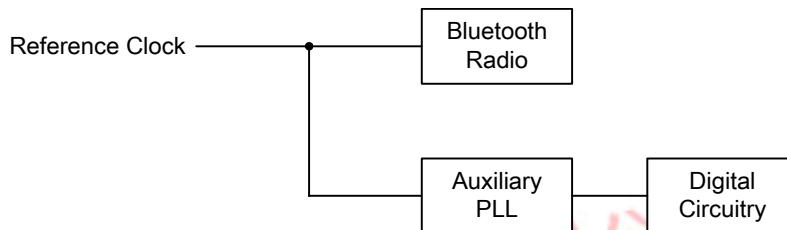

Figure 5.1: Clock Architecture

5.2 Input Frequencies and PS Key Settings

RoadTunes ROM QFN Automotive is configured to operate with a chosen reference frequency. Configuration is by setting the PS Key PSKEY_ANA_FREQ (0x01fe) for all frequencies with an integer multiple of 250kHz. The input frequency default setting for RoadTunes ROM QFN Automotive is 26MHz depending on the software build. Full details are in the software release note for the specific build from www.csrsupport.com.

5.3 Crystal Oscillator (XTAL_IN, XTAL_OUT)

RoadTunes ROM QFN Automotive contains a crystal driver circuit. This operates with an external crystal and capacitors to form a Pierce oscillator. The external crystal is connected to pins XTAL_IN, XTAL_OUT.

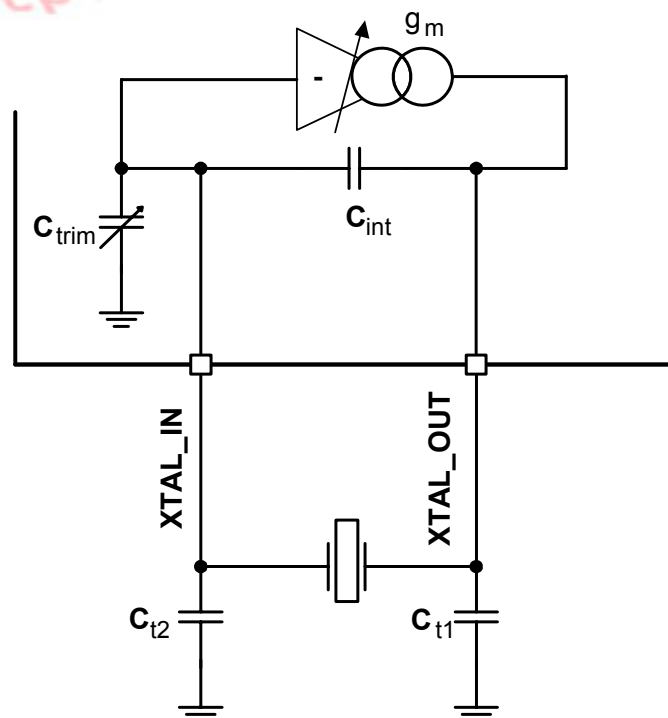

Figure 5.2: Crystal Driver Circuit

Figure 5.3 shows an electrical equivalent circuit for a crystal. The crystal appears inductive near its resonant frequency. It forms a resonant circuit with its load capacitors.

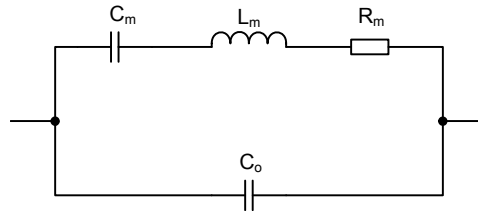

Figure 5.3: Crystal Equivalent Circuit

The resonant frequency may be trimmed with the crystal load capacitance. RoadTunes ROM QFN Automotive contains variable internal capacitors to provide a fine trim.

Parameter	Min	Typ	Max	Unit
Frequency	16	26	26	MHz
Initial Tolerance	-	±25	-	ppm
Pullability	-	±20	-	ppm/pF
Transconductance	2.0	-	-	mS

Table 5.1: Crystal Specification

The RoadTunes ROM QFN Automotive driver circuit is a transconductance amplifier. A voltage at XTAL_IN generates a current at XTAL_OUT. The value of transconductance is variable and may be set for optimum performance.

5.3.1 Load Capacitance

For resonance at the correct frequency the crystal should be loaded with its specified load capacitance, which is defined for the crystal. This is the total capacitance across the crystal viewed from its terminals. RoadTunes ROM QFN Automotive provides some of this load with the capacitors C_{trim} and C_{int} . The remainder should be from the external capacitors labelled C_{t1} and C_{t2} . C_{t1} should be three times the value of C_{t2} for best noise performance. This maximises the signal swing, hence slew rate at XTAL_IN (to which all on-chip clocks are referred).

Crystal load capacitance, C_l is calculated with Equation 5.1:

$$C_l = C_{int} + \frac{(C_{t2} + C_{trim}) C_{t1}}{C_{t2} + C_{trim} + C_{t1}}$$

Equation 5.1: Load Capacitance

Note:

$$C_{trim} = 3.4\text{pF nominal (mid-range setting)}$$

$$C_{int} = 1.5\text{pF}$$

C_{int} does not include the crystal internal self capacitance; it is the driver self capacitance.

5.3.2 Frequency Trim

RoadTunes ROM QFN Automotive enables frequency adjustments to be made. This feature is typically used to remove initial tolerance frequency errors associated with the crystal. Frequency trim is achieved by adjusting the crystal load capacitance with an on-chip trim capacitor, C_{trim} . The value of C_{trim} is set by a 6-bit word in the PS Key PSKEY_ANA_FTRIM (0x1f6). Its value is calculated as follows:

$$C_{trim} = 125\text{fF} \times \text{PSKEY_ANA_FTRIM}$$

Equation 5.2: Trim Capacitance

The C_{trim} capacitor is connected between XTAL_IN and ground. When viewed from the crystal terminals, the combination of the tank capacitors and the trim capacitor presents a load across the terminals of the crystal which varies in steps of typically 125fF for each least significant bit increment of PSKEY_ANA_FTRIM.

Equation 5.3 describes the frequency trim.

$$\frac{\Delta(F_x)}{F_x} = \text{pullability} \times 0.110 \times \left(\frac{C_{t1}}{C_{t1} + C_{t2} + C_{trim}} \right) (\text{ppm/LSB})$$

Equation 5.3: Frequency Trim

Note:

F_x = crystal frequency

Pullability is a crystal parameter with units of ppm/pF.

Total trim range is 0 to 63.

If not specified, the pullability of a crystal may be calculated from its motional capacitance with Equation 5.4.

$$\frac{\partial(F_x)}{\partial(C_1)} = F_x \cdot \frac{C_m}{2(C_1 + C_0)^2}$$

Equation 5.4: Pullability

Note:

C_0 = Crystal self capacitance (shunt capacitance)

C_m = Crystal motional capacitance (series branch capacitance in crystal model). See Figure 5.3.

It is a Bluetooth requirement that the frequency is always within ± 20 ppm. The trim range should be sufficient to pull the crystal within ± 5 ppm of the exact frequency. This leaves a margin of ± 15 ppm for frequency drift with ageing and temperature. A crystal with an ageing and temperature drift specification of better than ± 15 ppm is required.

5.3.3 Transconductance Driver Model

The crystal and its load capacitors should be viewed as a transimpedance element, whereby a current applied to one terminal generates a voltage at the other. The transconductance amplifier in RoadTunes ROM QFN Automotive uses the voltage at its input, XTAL_IN, to generate a current at its output, XTAL_OUT. Therefore, the circuit will oscillate if the transconductance, transimpedance product is greater than unity. For sufficient oscillation amplitude, the product should be greater than three. The transconductance required for oscillation is defined by the relationship shown in Equation 5.5.

$$g_m > 3 \frac{(2\pi F_x)^2 R_m ((C_0 + C_{int})(C_{t1} + C_{t2} + C_{trim}) + C_{t1} (C_{t2} + C_{trim}))}{C_{t1} (C_{t2} + C_{trim})}$$

Equation 5.5: Transconductance Required for Oscillation

RoadTunes ROM QFN Automotive guarantees a transconductance value of at least 2mA/V at maximum drive level.

Note:

More drive strength is required for higher frequency crystals, higher loss crystals (larger R_m) or higher capacitance loading.

Optimum drive level is attained when the level at XTAL_IN is approximately 1V pk-pk. The drive level is determined by the crystal driver transconductance.

5.3.4 Negative Resistance Model

An alternative representation of the crystal and its load capacitors is a frequency dependent resistive element. The driver amplifier may be considered as a circuit that provides negative resistance. For oscillation, the value of the negative resistance must be greater than that of the crystal circuit equivalent resistance. Although the RoadTunes ROM QFN Automotive crystal driver circuit is based on a transimpedance amplifier, an equivalent negative resistance can be calculated for it using Equation 5.6.

$$R_{\text{neg}} > \frac{C_{t1}(C_{t2} + C_{\text{trim}})}{g_m(2\pi F_x)^2(C_0 + C_{\text{int}})((C_{t1} + C_{t2} + C_{\text{trim}}) + C_{t1}(C_{t2} + C_{\text{trim}}))^2}$$

Equation 5.6: Equivalent Negative Resistance

This formula shows the negative resistance of the RoadTunes ROM QFN Automotive driver as a function of its drive strength.

The value of the driver negative resistance may be easily measured by placing an additional resistance in series with the crystal. The maximum value of this resistor (oscillation occurs) is the equivalent negative resistance of the oscillator.

5.3.5 Crystal PS Key Settings

The RoadTunes ROM QFN Automotive firmware automatically controls the drive level on the crystal circuit to achieve optimum input swing. The PS Key PSKEY_XTAL_TARGET_AMPLITUDE (0x24b) is used by the firmware to servo the required amplitude of crystal oscillation. Refer to the software build release note for a detailed description.

RoadTunes ROM QFN Automotive should be configured to operate with the chosen reference frequency.

5.4 External Reference Clock

5.4.1 Input (XTAL_IN)

The external reference clock is applied to the RoadTunes ROM QFN Automotive XTAL_IN input.

RoadTunes ROM QFN Automotive is configured to accept the external reference clock at XTAL_IN by connecting XTAL_OUT to ground. The external clock can be either a digital level square wave or sinusoidal, and this may be directly coupled to XTAL_IN without the need for additional components. A digital level reference clock gives superior noise immunity, as the high slew rate clock edges have lower voltage to phase conversion. If peaks of the reference clock are either below VSS or above VDD_ANA, it must be driven through a DC blocking capacitor (approximately 33pF) connected to XTAL_IN.

The external reference clock signal should meet the specifications outlined in Table 5.2.

		Min	Typ	Max	Unit
Frequency ^(a)		12	26	52	MHz
Duty cycle		20:80	50:50	80:20	
Edge jitter (at zero crossing)		-	-	15	ps rms
Signal level	AC coupled sinusoid	0.4	-	VDD_ANA ^(b)	V pk-pk
	DC coupled digital	V _{IL}	-	VSS ^(c)	V
		V _{IH}	-	VDD_ANA ^(b) (c)	V

Table 5.2: External Clock Specifications

^(a) The frequency should be an integer multiple of 250kHz except for the CDMA/3G frequencies

^(b) VDD_ANA is 1.50V nominal

^(c) If driven via a DC blocking capacitor max amplitude is reduced to 750mV pk-pk for non 50:50 duty cycle

5.4.2 XTAL_IN Impedance in External Mode

The impedance of XTAL_IN does not change significantly between operating modes, typically 10fF. When transitioning from Deep Sleep to an active state a spike of up to 1pC may be measured. For this reason CSR recommends that a buffered clock input is used.

5.4.3 Clock Start-up Delay

RoadTunes ROM QFN Automotive hardware incorporates an automatic 5ms delay after the assertion of the system clock request signal before running firmware. This is suitable for most applications using an external clock source. However, there may be scenarios where the clock cannot be guaranteed to either exist or be stable after this period. Under these conditions, RoadTunes ROM QFN Automotive firmware provides a software function that extends the system clock request signal by a period stored in PSKEY_CLOCK_STARTUP_DELAY. This value is set in milliseconds from 1-31ms. Zero is the default entry for 5ms delay.

This PS Key allows the designer to optimise a system where clock latencies may be longer than 5ms while still keeping the current consumption of RoadTunes ROM QFN Automotive as low as possible. RoadTunes ROM QFN Automotive consumes about 2mA of current for the duration of PSKEY_CLOCK_STARTUP_DELAY before activating the firmware.

5.4.4 Clock Timing Accuracy

As Figure 5.4 shows, the 250ppm timing accuracy on the external clock is required 2ms after the firmware begins to run. This is to guarantee that the firmware can maintain timing accuracy in accordance with the Bluetooth v2.0 + EDR specification. Radio activity may occur after 6ms after the firmware starts. Therefore, at this point the timing accuracy of the external clock source must be within ± 20 ppm.

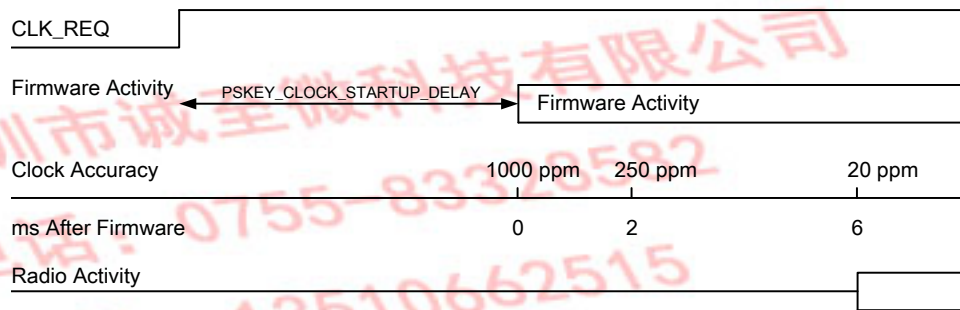

Figure 5.4: TCXO Clock Accuracy

6 Bluetooth Stack Microcontroller

A 16-bit RISC MCU is used for low power consumption and efficient use of memory.

The MCU, interrupt controller and event timer run the Bluetooth software stack and control the Bluetooth radio and host interfaces.

6.1 Programmable I/O Ports, PIO and AIO

RoadTunes ROM QFN Automotive contains 12 lines of programmable bidirectional I/O.

RoadTunes ROM QFN Automotive has 2 general-purpose analogue interface pins, AIO[1:0], used to access internal circuitry and control signals. Auxiliary functions available on the analogue interface include a 10-bit ADC.

Note:

The PIO and AIO configuration is dependent on the RoadTunes ROM Solution.

PIO[9:4] are powered from VDD_PADS and PIO[3:0] are powered from VDD_PIO. AIO[1:0] are powered from VDD_ANA.

深圳市诚至微科技有限公司
电话：0755-83328582
手机：13510662515
<http://www.czwtech.com>

7 Kalimba DSP

The Kalimba DSP is an open platform Kalimba DSP allowing signal processing functions to be performed on over air data or codec data in order to enhance audio applications. The Kalimba DSP interfaces to other functional blocks within RoadTunes ROM QFN Automotive as shown in Figure 7.1.

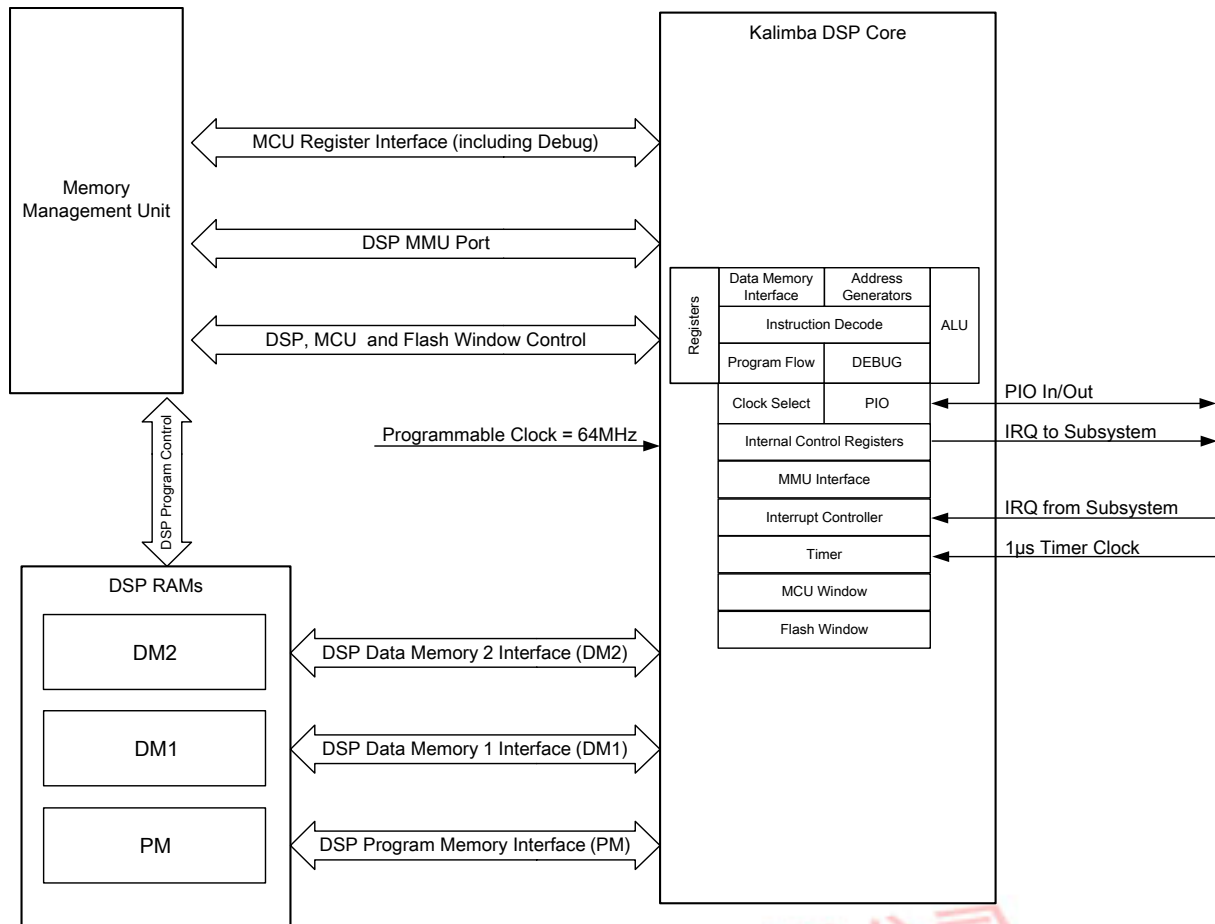

Figure 7.1: Kalimba DSP Interface to Internal Functions

The key features of the DSP include:

- 64MIPS performance, 24-bit fixed point DSP Core
- Single cycle MAC of 24 x 24-bit multiply and 56-bit accumulate
- 32-bit instruction word
- Separate program memory and dual data memory, allowing an ALU operation and up to two memory accesses in a single cycle
- Zero overhead looping
- Zero overhead circular buffer indexing
- Single cycle barrel shifter with up to 56-bit input and 24-bit output
- Multiple cycle divide (performed in the background)
- Bit reversed addressing
- Orthogonal instruction set
- Low overhead interrupt

8 Memory Interface and Management

8.1 Memory Management Unit

The MMU provides a number of dynamically allocated ring buffers that hold the data that is in transit between the host, the air or the Kalimba DSP. The dynamic allocation of memory ensures efficient use of the available RAM and is performed by a hardware MMU to minimise the overheads on the processor during data/voice transfers.

8.2 System RAM

48KB of on-chip RAM supports the RISC MCU and is shared between the ring buffers used to hold voice/data for each active connection and the general-purpose memory required by the Bluetooth stack.

8.3 Kalimba DSP RAM

Additional on-chip RAM is provided to support the Kalimba DSP:

- 8K x 24-bit for data memory 1 (DM1)
- 8K x 24-bit for data memory 2 (DM2)
- 6K x 32-bit for program memory (PM)

Note:

The DSP can also execute directly from internal ROM, using a 64-instruction on-chip cache.

8.4 Internal ROM

Internal ROM is provided for system firmware implementation.

9 Serial Interfaces

9.1 UART Interface

RoadTunes ROM QFN Automotive has a standard UART serial interface that provides a simple mechanism for communicating using RS232 protocol.

Note:

For RoadTunes ROM software information see *RoadTunes ROM Software Release Note*.



Figure 9.1: Universal Asynchronous Receiver

Figure 9.1 shows the 4 signals that implement the UART function. When RoadTunes ROM QFN Automotive is connected to another digital device, UART_RX and UART_TX transfer data between the 2 devices. The remaining 2 signals, UART_CTS and UART_RTS, can implement RS232 hardware flow control where both are active low indicators.

UART configuration parameters, such as baud rate and packet format, are set using RoadTunes ROM QFN Automotive firmware.

Note:

To communicate with the UART at its maximum data rate using a standard PC, an accelerated serial port adapter card is required for the PC.

Parameter		Possible Values
Baud rate	Minimum	1200 baud (≤2%Error)
		9600 baud (≤1%Error)
	Maximum	4Mbaud (≤1%Error)
Flow control		RTS/CTS or None
Parity		None, Odd or Even
Number of stop bits		1 or 2
Bits per byte		8

Table 9.1: Possible UART Settings

The UART interface can reset RoadTunes ROM QFN Automotive on reception of a break signal. A break is identified by a continuous logic low (0V) on the UART_RX terminal, as shown in Figure 9.2. If t_{BRK} is longer than the value, defined by the PS Key PSKEY_HOSTIO_UART_RESET_TIMEOUT, (0x1a4), a reset occurs. This feature allows a host to initialise the system to a known state. Also, RoadTunes ROM QFN Automotive can emit a break character that may be used to wake the host.



Figure 9.2: Break Signal

Table 9.2 shows a list of commonly used baud rates and their associated values for the PS Key PSKEY_UART_BAUDRATE (0x1be). There is no requirement to use these standard values. Any baud rate within the supported range can be set in the PS Key according to the formula in Equation 9.1.

$$\text{Baud Rate} = \frac{\text{PSKEY_UART_BAUDRATE}}{0.004096}$$

Equation 9.1: Baud Rate

Baud Rate	Persistent Store Value		Error
	Hex	Dec	
1200	0x0005	5	1.73%
2400	0x000a	10	1.73%
4800	0x0014	20	1.73%
9600	0x0027	39	-0.82%
19200	0x004f	79	0.45%
38400	0x009d	157	-0.18%
57600	0x00ec	236	0.03%
76800	0x013b	315	0.14%
115200	0x01d8	472	0.03%
230400	0x03b0	944	0.03%
460800	0x075f	1887	-0.02%
921600	0x0ebf	3775	0.00%
1382400	0x161e	5662	-0.01%
1843200	0x1d7e	7550	0.00%
2764800	0x2c3d	11325	0.00%
3686400	0x3afb	15099	0.00%

Table 9.2: Standard Baud Rates

9.1.1 UART Configuration While Reset is Active

The UART interface for RoadTunes ROM QFN Automotive is tri-state while the chip is being held in reset. This allows the user to daisy chain devices onto the physical UART bus. The constraint on this method is that any devices connected to this bus must tri-state when RoadTunes ROM QFN Automotive reset is de-asserted and the firmware begins to run.

9.2 Serial Peripheral Interface

The primary function of the SPI is for debug. RoadTunes ROM QFN Automotive uses a 16-bit data and 16-bit address SPI, where transactions may occur when the internal processor is running or is stopped. This section details the interface considerations for connection to RoadTunes ROM QFN Automotive.

Data may be written or read one word at a time, or the auto-increment feature is available for block access.

9.2.1 Instruction Cycle

The RoadTunes ROM QFN Automotive is the slave and receives commands on SPI_MOSI and outputs data on SPI_MISO. Table 9.3 shows the instruction cycle for an SPI transaction.

1	Reset the SPI interface	Hold SPI_CS# high for two SPI_CLK cycles
2	Write the command word	Take SPI_CS# low and clock in the 8-bit command
3	Write the address	Clock in the 16-bit address word
4	Write or read data words	Clock in or out 16-bit data word(s)
5	Termination	Take SPI_CS# high

Table 9.3: Instruction Cycle for an SPI Transaction

With the exception of reset, SPI_CS# must be held low during the transaction. Data on SPI_MOSI is clocked into the RoadTunes ROM QFN Automotive on the rising edge of the clock line SPI_CLK. When reading, RoadTunes ROM QFN Automotive replies to the master on SPI_MISO with the data changing on the falling edge of the SPI_CLK. The master provides the clock on SPI_CLK. The transaction is terminated by taking SPI_CS# high.

Sending a command word and the address of a register for every time it is to be read or written is a significant overhead, especially when large amounts of data are to be transferred. To overcome this RoadTunes ROM QFN Automotive offers increased data transfer efficiency via an auto increment operation. To invoke auto increment, SPI_CS# is kept low, which auto increments the address, while providing an extra 16 clock cycles for each extra word to be written or read.

9.2.2 Writing to the Device

To write to RoadTunes ROM QFN Automotive, the 8-bit write command (0000010) is sent first (C[7:0]) followed by a 16-bit address (A[15:0]). The next 16-bits (D[15:0]) clocked in on SPI_MOSI are written to the location set by the address (A). Thereafter for each subsequent 16-bits clocked in, the address (A) is incremented and the data written to consecutive locations until the transaction terminates when SPI_CS# is taken high.

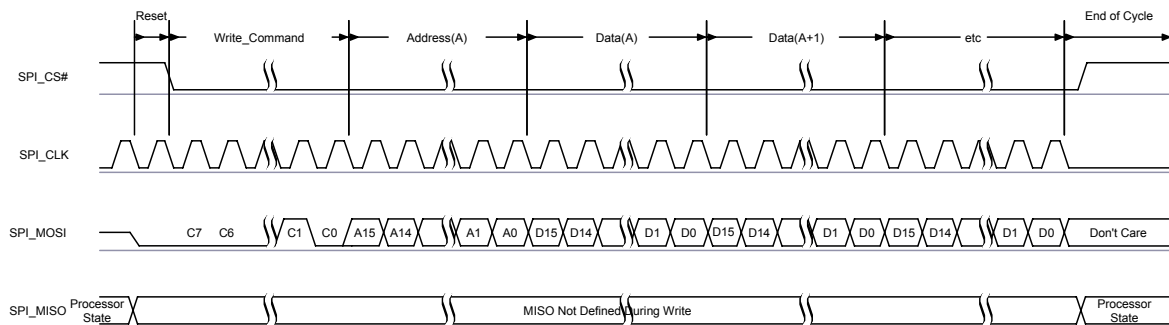

Figure 9.3: SPI Write Operation

9.2.3 Reading from the Device

Reading from RoadTunes ROM QFN Automotive is similar to writing to it. An 8-bit read command (0000011) is sent first (C[7:0]), followed by the address of the location to be read (A[15:0]). RoadTunes ROM QFN Automotive then outputs on SPI_MISO a check word during T[15:0] followed by the 16-bit contents of the addressed location during bits D[15:0].

The check word is composed of {command, address [15:8]}. The check word may be used to confirm a read operation to a memory location. This overcomes the problems encountered with typical serial peripheral interface slaves, whereby it is impossible to determine whether the data returned by a read operation is valid data or the result of the slave device not responding.

If SPI_CS# is kept low, data from consecutive locations is read out on SPI_MISO for each subsequent 16 clocks, until the transaction terminates when SPI_CS# is taken high.

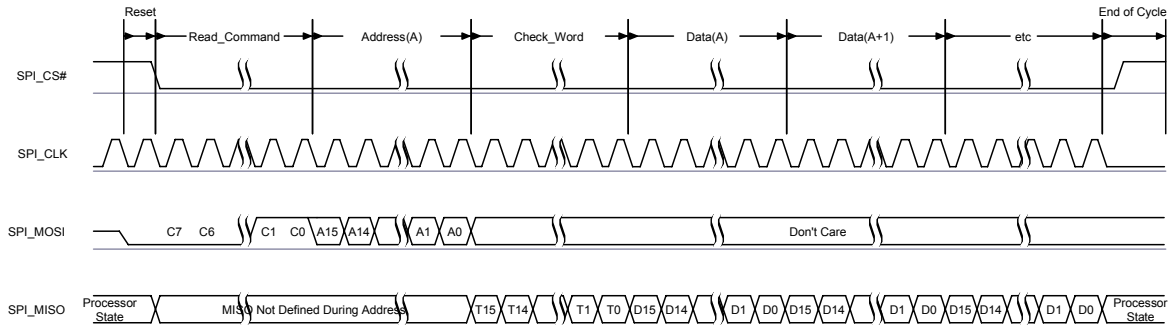

Figure 9.4: SPI Read Operation

9.2.4 Multi-slave Operation

RoadTunes ROM QFN Automotive should not be connected in a multi-slave arrangement by simple parallel connection of slave MISO lines. When RoadTunes ROM QFN Automotive is deselected (SPI_CS# = 1), the SPI_MISO line does not float. Instead, RoadTunes ROM QFN Automotive outputs 0 if the processor is running or 1 if it is stopped.

电话: 0755-8332...
 手机: 13510662515
<http://www.czwtech.com>

10 Audio Interface

The RoadTunes ROM QFN Automotive audio interface circuit consists of:

- Stereo audio DAC and outputs
- Dual channel mono voice band ADC with dual microphone inputs

The audio interface supports all requirements of the RoadTunes ROM Solution and Figure 10.1 shows the functional blocks of the RoadTunes ROM QFN Automotive audio interface. The audio interface supports stereo playback of audio signals at multiple sample rates with 16-bit resolution.

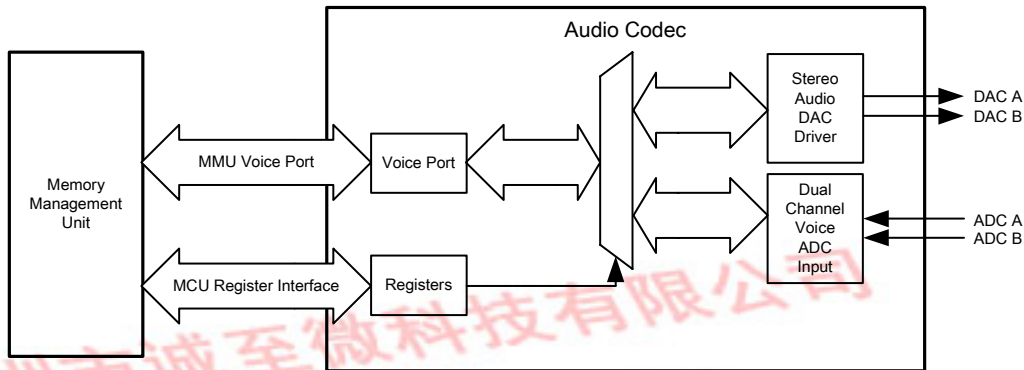

Figure 10.1: RoadTunes ROM QFN Automotive Audio Interface

10.1 Audio Input and Output

The audio input circuitry consists of a dual audio input that can be configured to be either single-ended or fully differential and programmed for either microphone or line input. It has an analogue and digital programmable gain stage for optimisation of different microphones.

The audio output circuitry consists of a dual differential class A-B output stage.

10.2 Audio Codec Interface

The main features of the interface are:

- Stereo and mono analogue output for voice band and audio band
- Dual mono analogue microphone input for voice band

Important Note:

To avoid any confusion regarding stereo operation this data sheet explicitly states which is the left and right channel for audio output. With respect to software and any registers, channel 0 or channel A represents the left channel and channel 1 or channel B represents the right channel for output.

10.2.1 Audio Codec Block Diagram

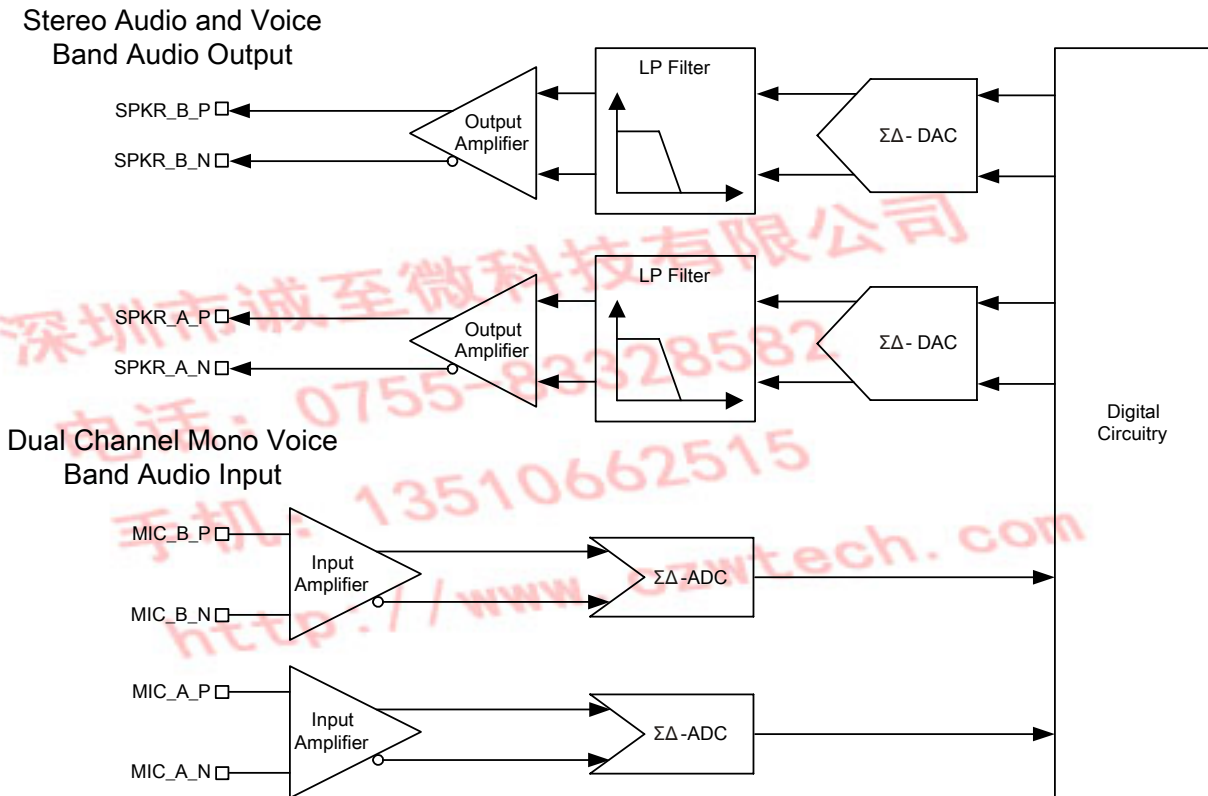

Figure 10.2: Codec Audio Input and Output Stages

The audio codec uses a fully differential architecture in the analogue signal path, which results in low noise sensitivity and good power supply rejection while effectively doubling the signal amplitude. It operates from a single power-supply of 1.5V and uses a minimum of external components.

10.2.2 ADC

The ADC consists of:

- Two second-order Sigma Delta converters allowing two separate channels that are identical in functionality, as shown in Figure 10.2.
- Two gain stages for each channel, one of which is an analogue gain stage and the other is a digital gain stage.

10.2.3 ADC Sample Rate

Each ADC supports 8kHz sample rate only.

10.2.4 ADC Digital Gain

The digital gain stage has a programmable selection value in the range of 0 to 15 with the associated ADC gain settings summarised in Table 10.1. There is also a high resolution digital gain mode that allows the gain to be changed in 1/32dB steps. Contact CSR for more information.

Gain Selection Value	ADC Digital Gain Setting (dB)
0	0
1	3.5
2	6
3	9.5
4	12
5	15.5
6	18
7	21.5
8	-24
9	-20.5
10	-18
11	-14.5
12	-12
13	-8.5
14	-6
15	-2.5

Table 10.1: ADC Digital Gain Rate Selection

10.2.5 ADC Analogue Gain

Figure 10.3 shows the equivalent block diagram for the ADC analogue amplifier. It is a two-stage amplifier:

- The first stage amplifier has a selectable gain of either bypass for line input mode or gain of 24dB gain for the microphone mode.
- The second stage has a programmable gain with seven individual 3dB steps. By combining the 24dB gain selection of the microphone input with the seven individual 3dB gain steps, the overall range of the analogue amplifier is approximately -3dB to 42dB in 3dB steps. All gain control of the ADC is controlled by the BlueTunes.

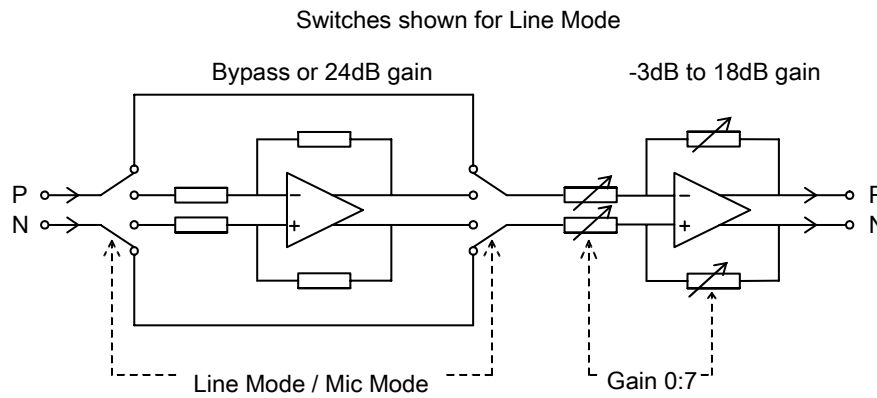

Microphone Mode input impedance = 6k Ω

Line mode input impedance = 6k Ω to 30k Ω

Figure 10.3: ADC Analogue Amplifier Block Diagram

10.2.6 DAC

The DAC consists of:

- Two second-order Sigma Delta converters allowing two separate channels that are identical in functionality, as shown in Figure 10.2.
- Two gain stages for each channel, one of which is an analogue gain stage and the other is a digital gain stage.

10.2.7 DAC Sample Rate Selection

Each DAC supports the following samples rates:

- 8kHz
- 11.025kHz
- 12kHz
- 16kHz
- 22.050kHz
- 24kHz
- 32kHz
- 44.1kHz
- 48kHz

10.2.8 DAC Digital Gain

The digital gain stage has a programmable selection value in the range of 0 to 15 with associated DAC gain settings, summarised in Table 10.2. There is also a high resolution digital gain mode that allows the gain to be changed in 1/32dB steps. Contact CSR for more information.

The overall gain control of the DAC is controlled by the BlueTunes. Its setting is a combined function of the digital and analogue amplifier settings.

Digital Gain Selection Value	DAC Digital Gain Setting (dB)
0	0
1	3.5
2	6
3	9.5
4	12

Digital Gain Selection Value	DAC Digital Gain Setting (dB)
5	15.5
6	18
7	21.5
8	-24
9	-20.5
10	-18
11	-14.5
12	-12
13	-8.5
14	-6
15	-2.5

Table 10.2: DAC Digital Gain Rate Selection

深圳市诚至微科技有限公司
 电话: 0755-83328582
 手机: 13510662515
<http://www.czwtech.com>

10.2.9 DAC Analogue Gain

As Table 10.3 shows the DAC analogue gain stage consists of eight gain selection values that represent seven 3dB steps.

The overall gain control of the DAC is controlled by the BlueTunes. Its setting is a combined function of the digital and analogue amplifier settings.

Analogue Gain Selection Value	DAC Analogue Gain Setting (dB)
7	3
6	0
5	-3
4	-6
3	-9
2	-12
1	-15
0	-18

Table 10.3: DAC Analogue Gain Rate Selection

10.2.10 Microphone Input

The microphone for each channel should be biased as shown in Figure 10.4. The microphone bias, MIC_BIAS, derives its power from the BAT_P and requires a 1 μ F capacitor on its output.

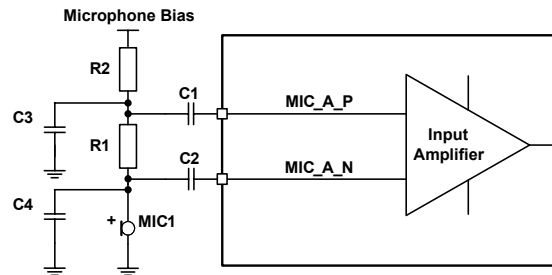

Figure 10.4: Microphone Biasing (Single Channel Shown)

The MIC_BIAS is like any voltage regulator and requires a minimum load to maintain regulation. The MIC_BIAS maintains regulation within the limits 0.200 - 1.230mA. If the microphone sits below these limits, then the microphone output must be pre-loaded with a large value resistor to ground.

The audio input is intended for use in the range from 1 μ A @ 94dB SPL to about 10 μ A @ 94dB SPL. With biasing resistors R1 and R2 equal to 1k Ω , this requires microphones with sensitivity between about -40dBV and -60dBV.

The input impedance at MIC_A_N, MIC_A_P, MIC_B_N and MIC_B_P is typically 6.0k Ω .

C1 and C2 should be 150nF if bass roll-off is required to limit wind noise on the microphone.

R1 sets the microphone load impedance and is normally in a range of 1 - 2k Ω .

R2, C3 and C4 improve the supply rejection by decoupling supply noise from the microphone. Values should be selected as required. R2 may be connected to a convenient supply, in which case the bias network is permanently enabled, or to the MIC_BIAS output (which is ground referenced and provides good rejection of the supply), which may be configured to provide bias only when the microphone is required.

The microphone bias provides a 4-bit programmable output voltage, shown in Table 10.4, with a 4-bit programmable output current, shown in Table 10.5.

The characteristics of the microphone bias include:

- Power supply:
 - RoadTunes ROM QFN Automotive microphone supply is BAT_P
 - Minimum input voltage = Output voltage + drop-out voltage
 - Maximum input voltage is 4.4V
 - Typically the microphone bias is at the same level as VDD_AUDIO (1.5V)
- Drop-out voltage:
 - 300mV minimum
 - Guaranteed for configuration of voltage or current output shown in Table 10.4 and Table 10.5
- Output voltage:
 - 4-bit programmable between 1.7 - 3.6V
 - Tolerance 90 - 110%
- Output current:
 - 4-bit programmable between 200 μ A – 1.230mA
 - Maximum current guaranteed to be >1mA
- Load capacitance:
 - Unconditionally stable for 1 μ F \pm 20% and 2.2 μ F \pm 20% pure C

Output Step	VOL_SET[3:0]	Min	Typ	Max	Units
0	0000	-	1.71	-	V
1	0001	-	1.76	-	V
2	0010	-	1.82	-	V
3	0011	-	1.87	-	V
4	0100	-	1.95	-	V
5	0101	-	2.02	-	V
6	0110	-	2.10	-	V
7	0111	-	2.18	-	V
8	1000	-	2.32	-	V
9	1001	-	2.43	-	V
10	1010	-	2.56	-	V
11	1011	-	2.69	-	V
12	1100	-	2.90	-	V
13	1101	-	3.08	-	V
14	1110	-	3.33	-	V
15	1111	-	3.57	-	V

Table 10.4: Voltage Output Steps

Output Step	CUR_SET[3:0]	Typ	Units
0	0000	0.200	mA
1	0001	0.280	mA
2	0010	0.340	mA
3	0011	0.420	mA
4	0100	0.480	mA
5	0101	0.530	mA
6	0110	0.610	mA
7	0111	0.670	mA
8	1000	0.750	mA
9	1001	0.810	mA
10	1010	0.860	mA
11	1011	0.950	mA
12	1100	1.000	mA
13	1101	1.090	mA
14	1110	1.140	mA
15	1111	1.230	mA

Table 10.5: Current Output Steps

Note:

For BAT_P, the PSRR at 100Hz - 22kHz, with >300mV supply headroom, decoupling capacitor of 1.1 μ F, is typically 58.9dB and worst case 53.4dB.

For VDD_AUDIO, the PSRR at 100Hz - 22kHz, decoupling capacitor of 1.1 μ F, is typically 88dB and worst case 60dB.

10.2.11 Line Input

If the input analogue gain is set to less than 24dB, RoadTunes ROM QFN Automotive automatically selects line input mode. In line input mode the first stage of the amplifier is automatically disabled, providing additional power saving. In line input mode the input impedance varies from 6k Ω - 30k Ω , depending on the volume setting. Figure 10.5 and Figure 10.6 show two circuits for line input operation and show connections for either differential or single-ended inputs.

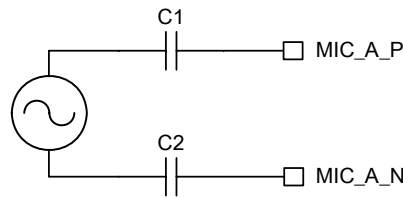

Figure 10.5: Differential Input (Single Channel Shown)

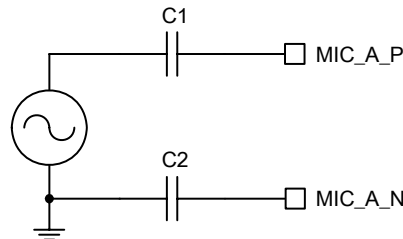

Figure 10.6: Single-Ended Input (Single Channel Shown)

10.2.12 Output Stage

The output stage digital circuitry converts the signal from 16-bit per sample, linear PCM of variable sampling frequency to bit stream, which is fed into the analogue output circuitry.

The output stage circuit comprises a DAC with gain setting and class AB output stage amplifier. The output is available as a differential signal between SPKR_A_N and SPKR_A_P for the left channel, as shown in Figure 10.7, and between SPKR_B_N and SPKR_B_P for the right channel.

The output stage is capable of driving a speaker directly when its impedance is at least 8Ω and an external regulator is used, but this will be at a reduced output swing.



Figure 10.7: Speaker Output (Single Channel Shown)

The analogue gain of the output stage is controlled by a 3-bit programmable resistive divider, which sets the gain in steps of approximately 3dB.

10.2.13 Mono Operation

Mono operation is a single-channel operation of the stereo codec. The left channel represents the single mono channel for audio in and audio out. In mono operation the right channel is auxiliary mono channel that may be used in dual mono channel operation.

In single channel mono operation, the power consumption can be reduced by disabling the other channel.

Important Note:

For mono operation this data sheet uses the left channel for standard mono operation for audio input and output and with respect to software and any registers, channel 0 or channel A represents the standard mono channel for audio input and output. In mono operation the second channel which is the right channel, channel 1 or channel B could be used as a second mono channel if required and this channel is referred to as the auxiliary mono channel for audio input and output.

10.2.14 Side Tone

In some applications it is necessary to implement side tone. This involves feeding an attenuated version of the microphone signal to the earpiece. The RoadTunes ROM QFN Automotive codec contains side tone circuitry to do this. The side tone hardware is configured through the following PS Keys:

- PSKEY_SIDE_TONE_ENABLE
- PSKEY_SIDE_TONE_GAIN
- PSKEY_SIDE_TONE_AFTER_ADC
- PSKEY_SIDE_TONE_AFTER_DAC

10.2.15 Integrated Digital Filter

RoadTunes ROM QFN Automotive has a programmable digital filter integrated into the ADC channel of the codec. The filter is a two stage, second order IIR and can be used for functions such as custom wind noise rejection. The filter also has optional DC blocking.

The filter has 10 configuration words used as follows:

- 1 for gain value
- 8 for coefficient values
- 1 for enabling and disabling the DC blocking

The gain and coefficients are all 12-bit 2's complement signed integer with the format XX.XXXXXXXXXXX

Note:

The position of the binary point is between bit 10 and bit 9, where bit 11 is the most significant bit.

For example:

- 01.1111111111 = most positive number, close to 2
- 01.0000000000 = 1
- 00.0000000000 = 0
- 11.0000000000 = -1
- 10.0000000000 = -2, most negative number

The equation for the IIR filter is shown in Equation 10.1. When the DC blocking is enabled the equation is shown in Equation 10.2.

The filter can be configured, enabled and disabled from the VM via the `CodecSetIIRFilterA` and `CodecSetIIRFilterB` traps. This requires firmware support. The configuration function takes 10 variables in the order shown below:

- 0 : Gain
- 1 : b_{01}
- 2 : b_{02}
- 3 : a_{01}

4 : a_{02}

5 : b_{11}

6 : b_{12}

7 : a_{11}

8 : a_{12}

9 : DC Block (1 = enable, 0 = disable)

$$\text{Filter, } H(z) = \text{Gain} \times \frac{(1 + b_{01} z^{-1} + b_{02} z^{-2})}{(1 + a_{01} z^{-1} + a_{02} z^{-2})} \times \frac{(1 + b_{11} z^{-1} + b_{12} z^{-2})}{(1 + a_{11} z^{-1} + a_{12} z^{-2})}$$

Equation 10.1: IIR Filter Transfer Function, $H(z)$

$$\text{Filter with DC Blocking, } H_{DC}(z) = H(z) \times (1 - z^{-1})$$

Equation 10.2: IIR Filter plus DC Blocking Transfer Function, $H_{DC}(z)$

10.3 PCM Interface

The audio PCM interface supports continuous transmission and reception of PCM encoded audio data over Bluetooth.

PCM is a standard method used to digitise audio (particularly voice) for transmission over digital communication channels. Through its PCM interface, RoadTunes ROM QFN Automotive has hardware support for continual transmission and reception of PCM data, so reducing processor overhead. RoadTunes ROM QFN Automotive offers a bi-directional digital audio interface that routes directly into the baseband layer of the on-chip firmware. It does not pass through the HCI protocol layer.

Hardware on RoadTunes ROM QFN Automotive allows the data to be sent to and received from a SCO connection.

Up to three SCO connections can be supported by the PCM interface at any one time.

RoadTunes ROM QFN Automotive can operate as the PCM interface master generating PCM_SYNC and PCM_CLK or as a PCM interface slave accepting externally generated PCM_SYNC and PCM_CLK. RoadTunes ROM QFN Automotive is compatible with various clock formats, including Long Frame Sync, Short Frame Sync and GCI timing environments.

It supports 13-bit or 16-bit linear, 8-bit μ -law or A-law companded sample formats, and can receive and transmit on any selection of three of the first four slots following PCM_SYNC. The PCM configuration options are enabled by setting the PS Key PS_KEY_PCM_CONFIG32 (0x1b3).

11 Power Control and Regulation

RoadTunes ROM QFN Automotive contains 3 regulators:

- One switch-mode regulator used to generate a 1.8V rail for the chip I/Os
- Two low-voltage regulators which run in parallel to supply the 1.5V core supplies from the 1.8V rail.

Various configurations for power control and regulation with RoadTunes ROM QFN Automotive are as follows:

- Powered from the switch-mode regulator and the low-voltage regulators in series, as shown in Figure 11.1
- Powered directly from an external 1.8V rail, omitting the switch-mode regulator
- Powered from an external 1.5V rail omitting all regulators

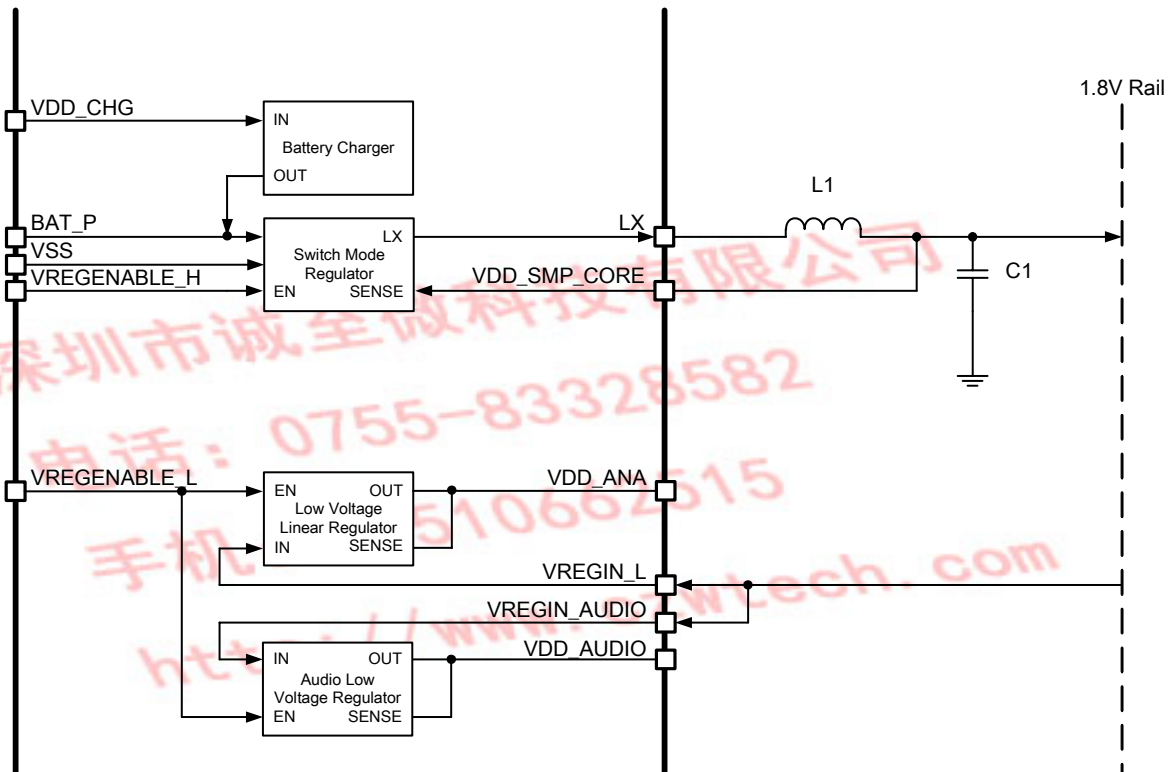

Figure 11.1: Voltage Regulator Configuration

11.1 Power Sequencing

The 1.50V supply rails are VDD_ANA, VDD_LO, VDD_RADIO, VDD_AUDIO and VDD_CORE. CSR recommends that these supply rails are all powered at the same time.

The digital I/O supply rails are VDD_PIO, VDD_PADS and VDD_UART.

The sequence of powering the 1.50V supply rails relative to the digital I/O supply rails is not important. If the digital I/O supply rails are powered before the 1.50V supply rails, all digital I/Os will have a weak pull-down irrespective of the reset state.

VDD_ANA, VDD_LO, VDD_RADIO and VDD_AUDIO can connect directly to a 1.50V supply.

A simple RC filter is recommended for VDD_CORE to reduce transients fed back onto the power supply rails.

The digital I/O supply rails are connected together or independently to an appropriate voltage rail. Decoupling of the digital I/O supply rails is recommended.

11.2 External Voltage Source

If any of the supply rails for RoadTunes ROM QFN Automotive are supplied from an external voltage source, rather than one of the internal voltage regulators, then it is recommended that VDD_LO, VDD_RADIO and VDD_AUDIO should have less than 10mV rms noise levels between 0 to 10MHz. Also avoid single tone frequencies.

The transient response of any external regulator used should match or be better than the internal regulator available on RoadTunes ROM QFN Automotive, refer to regulator characteristics in Section 13. It is essential that the power rail recovers quickly at the start of a packet, where the power consumption jumps to high levels.

11.3 Switch-mode Regulator

The on-chip switch-mode regulator is available to power a 1.8V supply rail.

An external LC filter circuit of a low-resistance series inductor, L1 (22 μ H), followed by a low ESR shunt capacitor, C1 (4.7 μ F), is required between the LX terminal and the 1.8V supply rail. A connection between the 1.8V supply rail and the VDD_SMP_CORE pin is required.

A decoupling capacitor (2.2 μ F) is required between BAT_P and VSS.

To maintain high-efficiency power conversion and low supply ripple, it is essential that the series resistance of tracks between the BAT_P and VSS terminals, the filter and decoupling components, and the external voltage source are minimised.

The switch-mode regulator is enabled by either:

- VREGENABLE_H pin
- RoadTunes ROM QFN Automotive device firmware
- RoadTunes ROM QFN Automotive battery charger

The switch-mode regulator is switched into a low-power pulse skipping mode when the device is sent into deep sleep mode, or in reset.

When the switch-mode regulator is not required the terminals BAT_P and LX must be grounded or left unconnected.

11.4 Low-voltage Linear Regulator

The low-voltage linear regulator is available to power a 1.5V supply rail. Its output is connected internally to VDD_ANA, and can be connected externally to the other 1.5V power inputs.

If the low-voltage linear regulator is used a smoothing circuit using a low ESR 2.2 μ F capacitor and a 2.2 Ω resistor to ground, should be connected to the output of the low-voltage linear regulator, VDD_ANA. Alternatively use a 2.2 μ F capacitor with an ESR of at least 2 Ω .

The low-voltage linear regulator is enabled by either:

- VREGENABLE_L pin
- RoadTunes ROM QFN Automotive device firmware
- RoadTunes ROM QFN Automotive battery charger

The low-voltage linear regulator is switched into a low power mode when the device is in deep sleep mode, or in reset.

When the low-voltage linear regulator is not used the terminal VREGIN_L must be left unconnected, or tied to VDD_ANA.

11.5 Low-voltage Audio Linear Regulator

The low-voltage audio linear regulator is available to power a 1.5V audio supply rail. Its output is connected internally to VDD_AUDIO, and can be connected externally to the other 1.5V audio power inputs.

If the low-voltage audio linear regulator is used a smoothing circuit using a low ESR 2.2 μ F capacitor and a 2.2 Ω resistor to ground, should be connected to the output of the low-voltage linear regulator, VDD_AUDIO. Alternatively use a 2.2 μ F capacitor with an ESR of at least 2 Ω .

The low-voltage audio linear regulator is enabled by either:

- VREGENABLE_L pin
- RoadTunes ROM QFN Automotive device firmware
- RoadTunes ROM QFN Automotive battery charger

The low-voltage audio linear regulator is switched into a low-power mode when no audio cells are enabled, or when the chip is in reset.

When this regulator is not used the terminal VREGIN_AUDIO must be left unconnected or tied to VDD_AUDIO.

11.6 Voltage Regulator Enable Pins

The voltage regulator enable pins, VREGENABLE_H and VREGENABLE_L, are used to enable the RoadTunes ROM QFN Automotive device if the on-chip regulators are being used. Table 11.1 shows the enable pin responsible for each voltage regulator.

Enable Pin	Regulator
VREGENABLE_H	Switch-mode Regulator
VREGENABLE_L	Low-voltage Linear Regulator and Low-voltage Audio Linear Regulator

Table 11.1: RoadTunes ROM QFN Automotive Voltage Regulator Enable Pins

The voltage regulator enable pins are active high, with weak pull-downs.

RoadTunes ROM QFN Automotive boots-up when the voltage regulator enable pins are pulled high, enabling the appropriate regulators. The firmware then latches the regulators on and the voltage regulator enable pins may then be released.

The status of the VREGENABLE_H pin is available to firmware through an internal connection. VREGENABLE_H also works as an input line.

11.7 Battery Charger

The battery charger is a constant current / constant voltage charger circuit, and is suitable for lithium ion/polymer batteries only. It shares a connection to the battery terminal, BAT_P, with the switch-mode regulator. However it may be used in conjunction with either of the high-voltage regulators on the device.

The constant current level can be varied to allow charging of different capacity batteries.

The charger enters various states of operation as it charges a battery, as listed below. A full operational description is in *BlueCore5 Charger Description and Calibration Application Note*.

- Off : entered when charger disconnected.
- Trickle charge: entered when battery is below 2.9V. The battery is charged at a nominal 4.5mA. This mode is for the safe charge of deeply discharged cells.
- Fast charge constant current: entered when battery is above 2.9V. The charger enters the main fast charge mode. This mode charges the battery at the selected constant current, I_{chgset} .
- Fast charge constant voltage: entered when battery has reached a selected voltage, V_{float} . The charger switches mode to maintain the cell voltage at the V_{float} voltage by adjusting the charge current.
- Standby: this is the state when the battery is fully charged and no charging takes place. The battery voltage is continuously monitored and if it drops by more than 150mV below the V_{float} voltage the charger will re-enter the fast charge constant current mode to keep the battery fully charged.

The battery charger circuitry auto-detects the presence of a power source, allowing the firmware to detect, using an internal status bit, when the charger is powered. Therefore when the charger supply is not connected to VDD_CHG, the terminal must be left open-circuit. The VDD_CHG pin when not connected must be allowed to float and not pulled to a power rail. When the battery charger is not enabled this pin may float to a low undefined voltage. Any DC connection increases current consumption of the device. Capacitive components may be connected such as diodes, FETs and ESD protection.

The battery charger is designed to operate with a permanently connected battery. If the application enables the charger input to be connected while the battery is disconnected, then the BAT_P pin voltage may become unstable. This in turn may cause damage to the internal switch-mode regulator. Connecting a 470 μ F capacitor to BAT_P limits these oscillations so preventing damage.

11.8 Reset, RST#

RoadTunes ROM QFN Automotive can be reset from several sources:

- RST# pin
- Power-on reset
- UART break character
- Software configured watchdog timer

The RST# pin is an active low reset and is internally filtered using the internal low frequency clock oscillator. A reset is performed between 1.5 and 4.0ms following RST# being active. CSR recommends that RST# be applied for a period greater than 5ms.

The power-on reset typically occurs when the VDD_CORE supply falls below 1.26V and is released when VDD_CORE rises above typically 1.31V. At reset the digital I/O pins are set to inputs for bidirectional pins and outputs are tristate. Following a reset, RoadTunes ROM QFN Automotive assumes the maximum XTAL_IN frequency, which ensures that the internal clocks run at a safe (low) frequency until RoadTunes ROM QFN Automotive is configured for the actual XTAL_IN frequency. If no clock is present at XTAL_IN, the oscillator in RoadTunes ROM QFN Automotive free runs, again at a safe frequency.

11.8.1 Digital Pin States on Reset

Table 11.2 shows the pin states of RoadTunes ROM QFN Automotive on reset.

Pin Name / Group	I/O Type	No Core Voltage Reset	Full Chip Reset
UART_RX	Digital input with PD	PD	PD
UART_CTS	Digital input with PD	PD	PD
UART_TX	Digital bidirectional with PU	PU	PU
UART_RTS	Digital bidirectional with PU	PU	PU
SPI_MOSI	Digital input with PD	PD	PD
SPI_CLK	Digital input with PD	PD	PD
SPI_CS#	Digital input with PU	PU	PU
SPI_MISO	Digital tristate output with PD	PD	PD
RST#	Digital input with PU	PU	PU
TEST_EN	Digital input with PD	PD	PD
PIO[15:11,9:0,0:15]	Digital bidirectional with PU/ PD	PD	PD

Table 11.2: RoadTunes ROM QFN Automotive Digital Pin States on Reset

Note:

PU = pull-up

PD = pull-down

Pull-up and pull-down default to weak values unless specified otherwise

11.8.2 Status after Reset

The chip status after a reset is as follows:

- Warm reset: data rate and RAM data remain available
- Cold reset: data rate and RAM data not available

12 Example Application Schematic

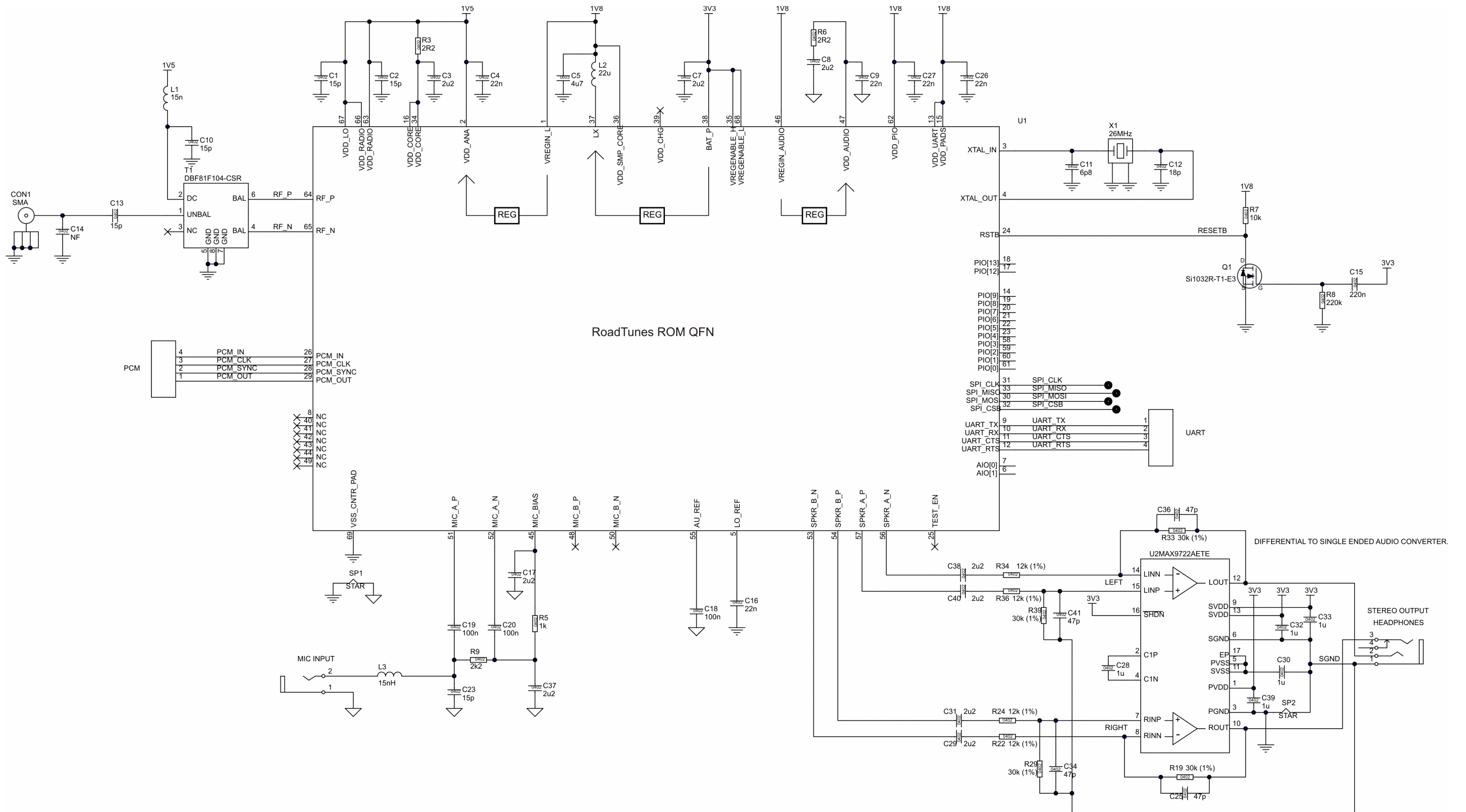

Figure 12.1: RoadTunes ROM QFN Automotive Example Application Schematic

13 Electrical Characteristics

13.1 Absolute Maximum Ratings

Rating		Min	Max	Unit
Storage Temperature		-40	105	°C
Core supply voltage	VDD_ANA, VDD_LO, VDD_RADIO, VDD_AUDIO and VDD_CORE	-0.4	1.65	V
I/O voltage	VDD_PIO, VDD_PADS and VDD_UART	-0.4	3.6	V
Supply voltage	VREGIN_L	-0.4	2.7	V
	VREGIN_AUDIO	-0.4	2.7	V
	VREGENABLE_H and VREGENABLE_L	-0.4	4.9	V
	BAT_P	-0.4	4.4	V
	VDD_CHG	-0.4	6.5	V
Other terminal voltages		VSS - 0.4	VDD + 0.4	V

13.2 Recommended Operating Conditions

Operating Condition		Min	Typ	Max	Unit
Operating temperature range		-20	20	70	°C
Core supply voltage	VDD_ANA, VDD_LO, VDD_RADIO, VDD_AUDIO and VDD_CORE	1.42	1.50	1.57	V
I/O supply voltage	VDD_PIO, VDD_PADS and VDD_UART	1.7	3.3	3.6	V

Note:

For radio performance over temperature refer to *RoadTunes ROM QFN Automotive Performance Specification*.

RoadTunes ROM QFN Automotive operates up to the maximum supply voltage given in the Absolute Maximum Ratings, but RF performance is not guaranteed above 4.2V.

13.3 Input/Output Terminal Characteristics

Note:

For all I/O Terminal Characteristics:

- VDD_ANA, VDD_LO, VDD_RADIO, VDD_AUDIO and VDD_CORE at 1.50V unless shown otherwise.
- VDD_PIO, VDD_PADS and VDD_UART at 3.3V unless shown otherwise.
- Current drawn into a pin is defined as positive; current supplied out of a pin is defined as negative.

13.3.1 Low-voltage Linear Audio Regulator

Normal Operation	Min	Typ	Max	Unit
Input voltage	1.70	1.80	1.95	V
Output voltage ($I_{load} = 70\text{mA}$ / VREGIN_AUDIO = 1.7V)	1.42	1.50	1.57	V
Temperature coefficient	-300	0	300	ppm/°C
Output noise ^{(a) (b)}	-	-	1	mV rms
Load regulation ($100\mu\text{A} < I_{load} < 70\text{mA}$), ΔV_{out}	-	-	5	mV
Settling time ^{(a) (c)}	-	-	50	μs
Maximum output current	70	-	-	mA
Minimum load current	5	-	100	μA
Dropout voltage ($I_{load} = 70\text{mA}$)	-	-	300	mV
Quiescent current (excluding load, $I_{load} < 1\text{mA}$)	25	30	50	μA
Low-power Mode ^(d)				
Quiescent current (excluding load, $I_{load} < 100\mu\text{A}$)	5	8	15	μA

^(a) Regulator output connected to 47nF pure and 4.7 μF 2.2 Ω ESR capacitors.

^(b) Frequency range 100Hz to 100kHz.

^(c) 1mA to 70mA pulsed load.

^(d) The regulator is in low power mode when the chip is in deep sleep mode, or in reset.

13.3.2 Switch-mode Regulator

Switch-mode Regulator	Min	Typ	Max	Unit
Input voltage	2.5	-	4.4	V
Output voltage ($I_{load} = 70\text{mA}$)	1.70	1.80	1.90	V
Temperature coefficient	-250	-	250	ppm/°C
Normal Operation				
Output ripple	-	-	10	mV rms
Transient settling time ^(a)	-	-	50	μs
Maximum load current	200	-	-	mA
Conversion efficiency ($I_{load} = 70\text{mA}$)	-	90	-	%
Switching frequency ^(b)	-	1.333	-	MHz
Start-up current limit ^(c)	30	50	80	mA
Low-power Mode ^(d)				
Output ripple	-	-	1	mV rms
Transient settling time ^(e)	-	-	700	μs
Maximum load current	5	-	-	mA
Minimum load current	1	-	-	μA
Conversion efficiency ($I_{load} = 1\text{mA}$)	-	80	-	%
Switching frequency ^(f)	50	-	150	kHz

^(a) For step changes in load of 30 to 80mA and 80 to 30mA.

^(b) Locked to crystal frequency.

^(c) Current is limited on start-up to prevent excessive stored energy in the filter inductor.

^(d) The regulator is in low power mode when the chip is in deep sleep mode, or in reset.

^(e) 100μA to 1mA pulsed load.

^(f) Defines minimum period between pulses. Pulses are skipped at low current loads.

Note:

The external inductor used with the switch-mode regulator must have an ESR in the range 0.3Ω to 0.7Ω:

- Low ESR < 0.3Ω causes instability.
- High ESR > 0.7Ω derates the maximum current.

13.3.3 Battery Charger

Battery Charger	Min	Typ	Max	Unit
Input voltage	4.5	-	6.5	V

Charging Mode (BAT_P rising to 4.2V)		Min	Typ	Max	Unit
Supply current ^(a)		-	4.5	6	mA
Battery trickle charge current ^(b)		-	4	-	mA
Maximum battery fast charge current (I-CTRL = 15) ^{(c) (d)}	Headroom ^(e) > 0.7V	-	140	-	mA
	Headroom = 0.3V	-	120	-	mA
Minimum battery fast charge current (I-CTRL = 0) ^{(c) (d)}	Headroom > 0.7V	-	40	-	mA
	Headroom = 0.3V	-	35	-	mA
Fast charge step size (I-CTRL = 0 to 15)	Spread $\pm 17\%$	-	6.3	-	mA
Trickle charge voltage threshold		-	2.9	-	V
Float voltage (with correct trim value set), V _{FLOAT} ^(f)		4.17	4.2	4.23	V
Float voltage trim step size ^(f)		-	50	-	mV
Battery charge termination current, % of fast charge current		5	10	20	%

^(a) Current into VDD_CHG does not include current delivered to battery ($I_{VDD_CHG} - I_{BAT_P}$)

^(b) BAT_P < Float voltage

^(c) Charge current can be set in 16 equally spaced steps.

^(d) Trickle charge threshold < BAT_P < Float voltage

^(e) Where headroom = VDD_CHG - BAT_P

^(f) Float voltage can be adjusted in 15 steps. Trim setting is determined in production test and must be loaded into the battery charger by firmware during boot-up sequence

Standby Mode (BAT_P falling from 4.2V)	Min	Typ	Max	Unit
Supply current ^(a)	-	1.5	2	mA
Battery current	-	-5	-	μ A
Battery recharge hysteresis ^(b)	100	-	200	mV

^(a) Current into VDD_CHG - does not include current delivered to battery ($I_{VDD_CHG} - I_{BAT_P}$)

^(b) Hysteresis of (V_{FLOAT} - BAT_P) for charging to restart

Shutdown Mode (VDD_CHG too low or disabled by firmware)		Min	Typ	Max	Unit
Supply current		-	1.5	2	mA
Battery current		-1	-	0	μA
VDD_CHG under-voltage threshold	VDD_CHG rising	-	3.90	-	V
	VDD_CHG falling	-	3.70	-	V
VDD_CHG - BAT_P lockout threshold	VDD_CHG rising	-	0.22	-	V
	VDD_CHG falling	-	0.17	-	V

13.3.4 Reset

Power-on Reset	Min	Typ	Max	Unit
VDD_CORE falling threshold	1.13	1.25	1.30	V
VDD_CORE rising threshold	1.20	1.30	1.35	V
Hysteresis	0.05	0.10	0.15	V

13.3.5 Regulator Enable

Switching Threshold	Min	Typ	Max	Unit
VREGENABLE_H				
Rising threshold	0.50	-	0.95	V
Falling threshold	0.35	-	0.80	V
Hysteresis	0.14	-	0.28	V
VREGENABLE_L				
Rising threshold	0.50	-	0.95	V
Falling threshold	0.35	-	0.80	V
Hysteresis	0.14	-	0.28	V

13.3.6 Digital Terminals

Supply Voltage Levels		Min	Typ	Max	Unit
VDD _{PRE}	Pre-driver supply voltage	1.4	1.5	1.6	V
VDD I/O supply voltage (post-driver)	Full spec.	3.0	3.3	3.6	V
	Reduced spec.	1.7	-	3.0	V

Input Voltage Levels	Min	Typ	Max	Unit
V _{IL} input logic level low	-0.3	-	0.25 x VDD	V
V _{IH} input logic level high	0.625 x VDD	-	VDD + 0.3	V
V _{SCHMITT} Schmitt voltage	0.25 x VDD	-	0.625 x VDD	V

Output Voltage Levels	Min	Typ	Max	Unit
V _{OL} output logic level low, I _{OL} = 4.0mA	0	-	0.125	V
V _{OH} output logic level high, I _{OH} = -4.0mA	0.75 x VDD	-	VDD	V

Input and Tristate Currents	Min	Typ	Max	Unit
I _i input leakage current at V _{in} = VDD or 0V	-100	0	100	nA
I _{oz} tristate output leakage current at V _o = VDD or 0V	-100	0	100	nA
With strong pull-up	-100	-40	-10	μA
With strong pull-down	10	40	100	μA
With weak pull-up	-5	-1.0	-0.2	μA
With weak pull-down	-0.2	1.0	5.0	μA
C ₁ Input Capacitance	1.0	-	5.0	pF

Resistive Strength	Min	Typ	Max	Unit
R _{puw} weak pull-up strength at VDD - 0.2V	0.5	-	2	MΩ
R _{pdw} weak pull-down strength at 0.2V	0.5	-	2	MΩ
R _{pus} strong pull-up strength at VDD - 0.2V	10	-	50	kΩ
R _{pds} strong pull-down strength at 0.2V	10	-	50	kΩ

13.3.7 Mono Codec: Analogue to Digital Converter

Analogue to Digital Converter						
Parameter	Conditions		Min	Typ	Max	Unit
Resolution			-	-	16	Bits
Input Sample Rate, F_{sample}			-	8	-	kHz
Signal to Noise Ratio, SNR	$f_{\text{in}} = 1\text{kHz}$ B/W = 20Hz→20kHz A-Weighted THD+N < 1% 150mV _{pk-pk} input	F_{sample}				
		8kHz	-	79	-	dB
Digital Gain	Digital Gain Resolution = 1/32dB		-24	-	21.5	dB
Analogue Gain	Analogue Gain Resolution = 3dB		-	-	42	dB
Input full scale at maximum gain (differential)			-	4	-	mV rms
Input full scale at minimum gain (differential)			-	800	-	mV rms
3dB Bandwidth			-	20	-	kHz
Microphone mode impedance			-	6.0	-	k Ω
THD+N (microphone input) @ 30mV rms input			-	0.04	-	%

13.3.8 Stereo Codec: Digital to Analogue Converter

Digital to Analogue Converter						
Parameter	Conditions		Min	Typ	Max	Unit
Resolution	-		-	-	16	Bits
Output Sample Rate, F_{sample}	-		8	-	48	kHz
Signal to Noise Ratio, SNR	$f_{\text{in}} = 1\text{kHz}$ B/W = 20Hz→20kHz A-Weighted THD+N < 0.01% 0dBFS signal Load = 100k Ω	F_{sample}				
		8kHz	-	95	-	dB
		11.025kHz	-	95	-	dB
		16kHz	-	95	-	dB
		22.050kHz	-	95	-	dB
		32kHz	-	95	-	dB
		44.1kHz	-	95	-	dB
		48kHz	-	95	-	dB
Digital Gain	Digital Gain Resolution = 1/32dB		-24	-	21.5	dB
Analogue Gain	Analogue Gain Resolution = 3dB		0	-	-21	dB
Output voltage full-scale swing (differential) ^(a)			-	750	-	mV rms
Allowed Load	Resistive		16(8)	-	O.C.	Ω
	Capacitive		-	-	500	pF
THD+N 100k Ω load			-	-	0.01	%
THD+N 16 Ω load			-	-	0.1	%
SNR (Load = 16 Ω , 0dBFS input relative to digital silence)			-	95	-	dB

^(a) Any combination of gain (digital and / or analogue) and input signal which results in the output signal level exceeding the minimum or maximum signal level (analogue or digital) could result in distortion.

13.3.9 Clocks

Clock Source	Min	Typ	Max	Unit
Crystal Oscillator				
Crystal frequency ^(a)	16	26	26	MHz
Digital trim range ^(b)	5.0	6.2	8.0	pF
Trim step size ^(b)	-	0.1	-	pF
Transconductance	2.0	-	-	mS

Clock Source	Min	Typ	Max	Unit
Negative resistance ^(c)	870	1500	2400	Ω
External Clock				
Input frequency ^(d)	12	26	52	MHz
Clock input level ^(e)	0.4	-	VDD_ANA	V pk-pk
Edge jitter (allowable jitter), at zero crossing	-	-	15	ps rms
XTAL_IN input impedance	-	≥10	-	kΩ
XTAL_IN input capacitance	-	≤4	-	pF

^(a) Integer multiple of 250kHz

^(b) The difference between the internal capacitance at minimum and maximum settings of the internal digital trim.

^(c) XTAL frequency = 16MHz; XTAL C₀ = 0.75pF; XTAL load capacitance = 8.5pF.

^(d) Clock input can be any frequency between 12MHz to 52MHz in steps of 250kHz plus CDMA/3G TCXO frequencies of 14.40, 15.36, 16.2, 16.8, 19.2, 19.44, 19.68, 19.8 and 38.4MHz.

^(e) Clock input can be either sinusoidal or square wave. If the peaks of the signal are below VSS or above VDD_ANA. A DC blocking capacitor is required between the signal and XTAL_IN.

13.3.10 Auxiliary ADC

Auxiliary ADC	Min	Typ	Max	Unit
Resolution	-	-	10	Bits
Input voltage range ^(a)	0	-	VDD_ANA	V
Accuracy (Guaranteed monotonic)	INL	-1	1	LSB
	DNL	0	1	LSB
Offset	-1	-	1	LSB
Gain Error	-0.8	-	0.8	%
Input Bandwidth	-	100	-	kHz
Conversion time	-	2.5	-	μs
Sample rate ^(b)	-	-	700	Samples/ s

^(a) LSB size = VDD_ANA/1023

^(b) The auxiliary ADC is accessed through a VM function. The sample rate given is achieved as part of this function.

14 CSR Green Semiconductor Products and RoHS Compliance

14.1 RoHS Statement

RoadTunes ROM QFN Automotive where explicitly stated in this Data Sheet meets the requirements of Directive 2002/95/EC of the European Parliament and of the Council on the *Restriction of Hazardous Substance* (RoHS).

14.1.1 List of Restricted Materials

RoadTunes ROM QFN Automotive is compliant with RoHS in relation to the following substances:

- Cadmium
- Lead
- Mercury
- Hexavalent chromium
- Polybrominated Biphenyl
- Polybrominated Diphenyl Ether

In addition, the following substances are not intentionally added to RoadTunes ROM QFN Automotive devices:

- Halogenated flame retardant
- Antimony (Sb) and Compounds, including Antimony Trioxide flame retardant
- Polybrominated Diphenyl and Biphenyl Oxides
- Tetrabromobisphenol-A bis (2,3-dibromopropylether)
- Asbestos or Asbestos compounds
- Azo compounds
- Organic tin compounds
- Mirex
- Polychlorinated naphthalenes
- Polychlorinated terphenyls
- Polychlorinated biphenyls
- Polychlorinated/Short chain chlorinated paraffins
- Polyvinyl Chloride (PVC) and PVC blends
- Formaldehyde
- Arsenic and compounds (except as a semiconductor dopant)
- Beryllium and its compounds
- Ethylene Glycol Monomethyl Ether or its acetate
- Ethylene Glycol Monoethyl Ether or its acetate
- Halogenated dioxins and furans
- Persistent Organic Pollutants (POP), including Perfluorooctane sulphonates
- Red phosphorous
- Ozone Depleting Chemicals (Class I and II): Chlorofluorocarbons (CFC) and Halons
- Radioactive substances

For further information, see CSR's *Environmental Compliance Statement for CSR Green Semiconductor Products*.

15 RoadTunes ROM QFN Automotive Software Stack

RoadTunes ROM QFN Automotive is supplied with Bluetooth v2.0 + EDR specification compliant stack firmware, which runs on the internal RISC MCU. Echo and noise suppression along with stereo streaming codecs are available. These run from the internal Kalimba DSP.

The RoadTunes ROM QFN Automotive software architecture completely embeds the Bluetooth operation within the chip itself. To control the operation of the various RoadTunes Bluetooth profiles, a layer of control software should be integrated on the external host processor, this layer of software controls the Bluetooth operation of the RoadTunes ROM QFN Automotive chipset by sending RoadTunes software commands via the UART interface.

15.1 Standalone RoadTunes ROM QFN Automotive and Kalimba DSP Applications

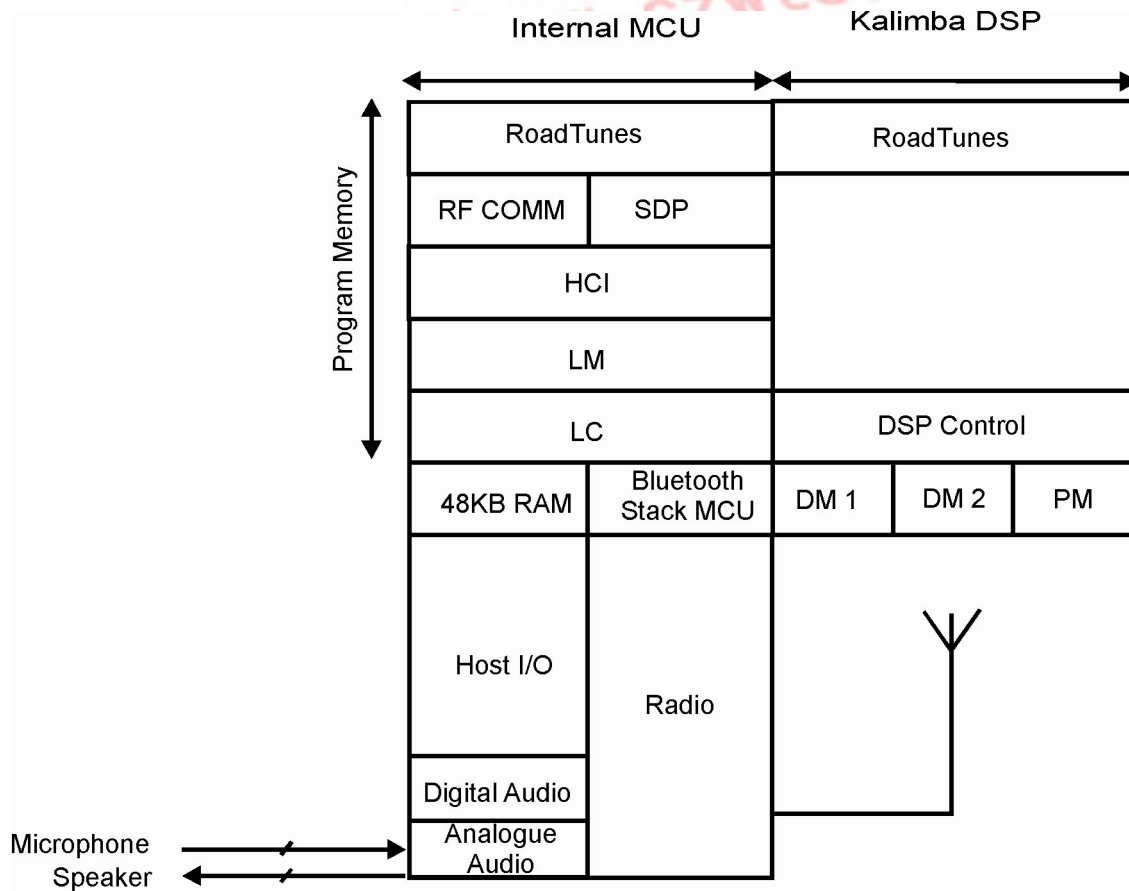

Figure 15.1: Standalone Application: RoadTunes ROM Solution

Note:

Program memory in Figure 15.1 is internal ROM.

Figure 15.1 shows how the RoadTunes ROM Solution is built on to the RoadTunes ROM QFN Automotive stack. The application requires a host processor, which can communicate over a UART. All software layers, including the RoadTunes ROM Solution software, RFCOMM, HCI stack etc. run internally.

Section 15.3 describes the features of the RoadTunes ROM Solution software, some of these features are run as DSP application code in the DSP program memory RAM, e.g. cVc algorithm. This code executes alongside the main RoadTunes ROM QFN Automotive firmware.

Section 15.2 describes the development tools for the RoadTunes ROM Solution.

15.2 RoadTunes ROM Solution Development Kit, DEV-RR-CT-SDK-01A

CSR's RoadTunes ROM Solution development kit for RoadTunes ROM QFN Automotive, order code DEV-RR-CT-SDK-01A, includes a headset demonstrator board, form-factor representative example design, audio adapter, music and voice dongle and necessary interface adapters and cables. In conjunction with the BlueTunes Configurator tool and other supporting utilities the development kit provides the best environment for designing a stereo headset solution with RoadTunes ROM QFN Automotive.

15.3 RoadTunes ROM QFN Automotive Software, BC57K687A07-IQF

Bluetooth embedded solution running on BlueCore[®]5-Multimedia ROM QFN and controlled via a simple host message interface making it cost competitive.

Features:

- Bluetooth v2.0 + EDR specification
- PBAP
- HFP
- A2DP source and sink
- AVRCP target and controller
- SPP
- DUN DT
- SBC codec support for stereo streaming
- Pairing with up to 8 devices
- AEC and NR using CSRs cVc[®]Gen 4 algorithm.

The configurable software setup enables:

- Auto-reconnect on start-up
- Reconnect on link-loss
- Security mode
- Connection and discovery

16 Tape and Reel Information

For tape and reel packing and labelling see *IC Packing and Labelling Specification*.

16.1 Tape Orientation

Figure 16.1 shows the RoadTunes ROM QFN Automotive packing tape orientation.

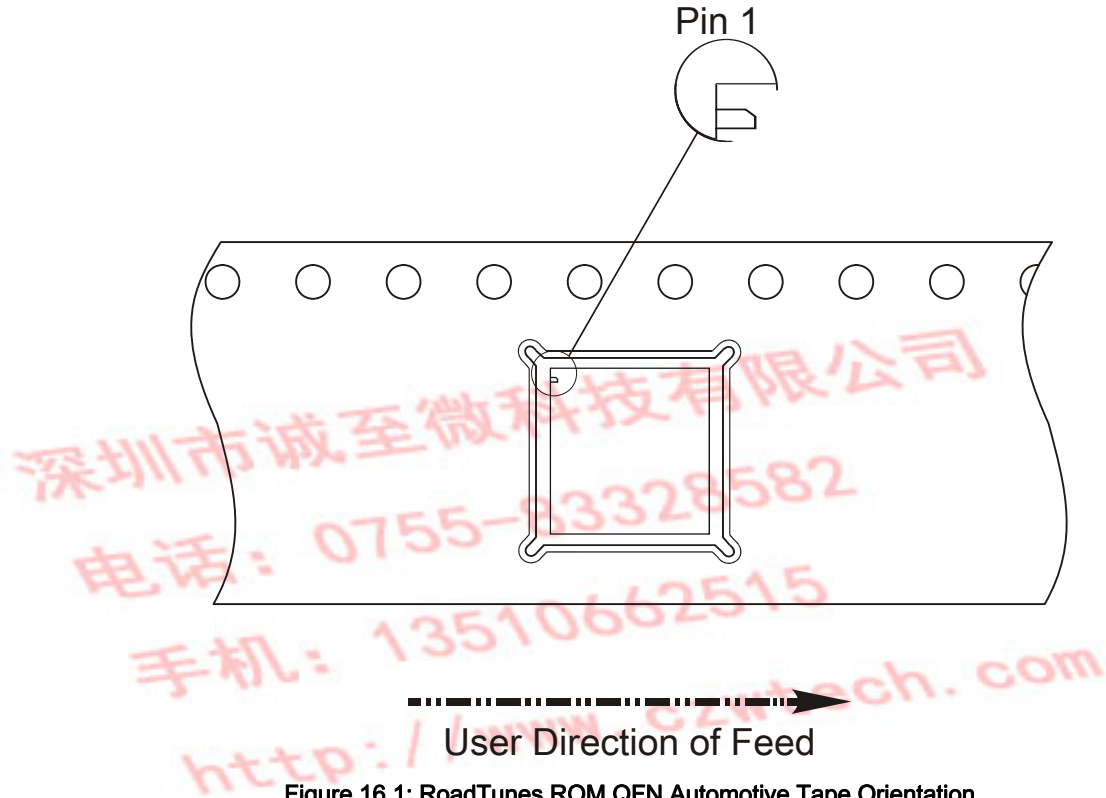
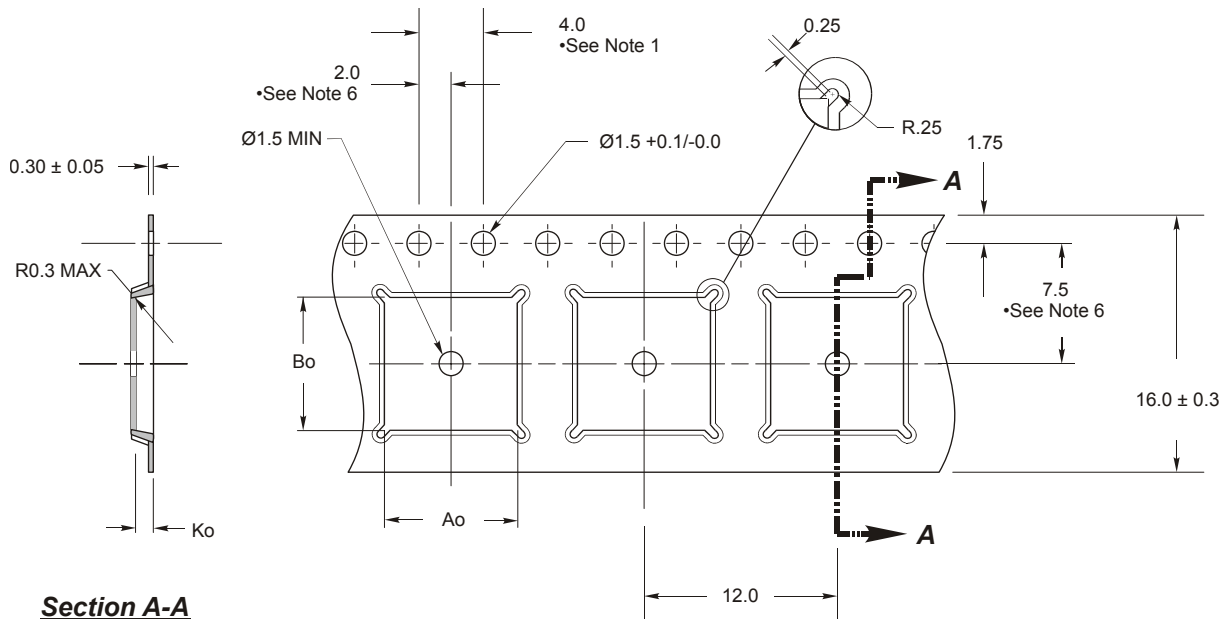

Figure 16.1: RoadTunes ROM QFN Automotive Tape Orientation

16.2 Tape Dimensions



Section A-A

A ₀	B ₀	K ₀	Unit	Notes
8.30	8.30	1.10	mm	<ol style="list-style-type: none"> 10 sprocket hole pitch cumulative tolerance ± 0.2 Camber not to exceed 1mm in 100mm Material: PS + C A₀ and B₀ measured as indicated K₀ measured from a plane on the inside bottom of the pocket to the top surface of the carrier Pocket position relative to sprocket hole measured as true position of pocket, not pocket hole

16.3 Reel Information

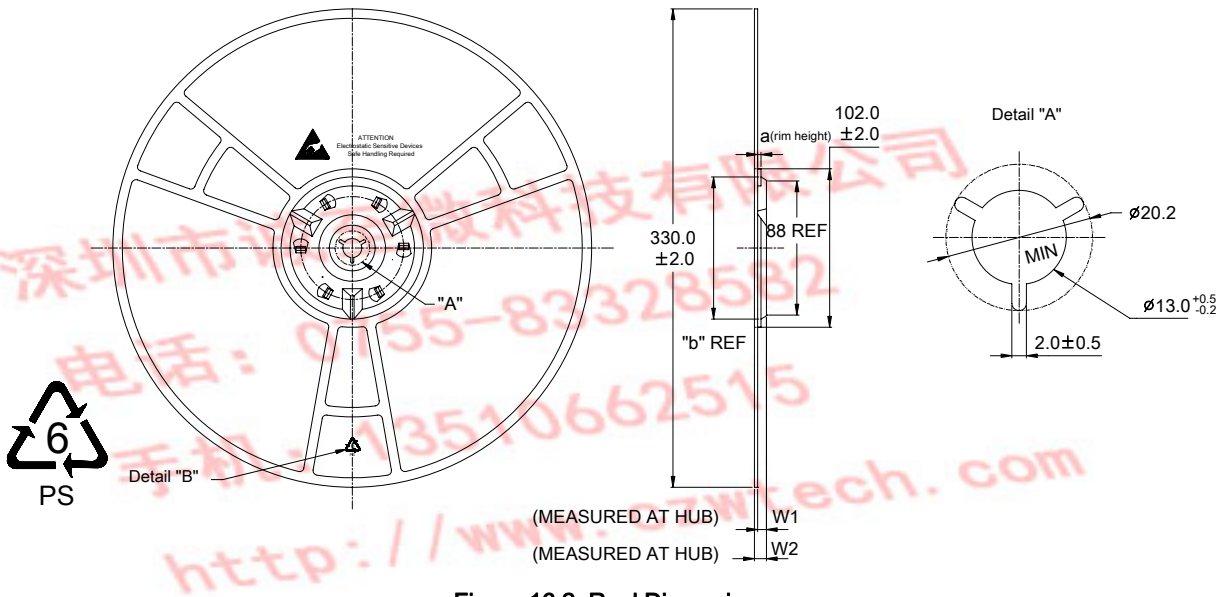

Figure 16.2: Reel Dimensions

Package Type	Nominal Hub Width (Tape Width)	a	b	W1	W2 Max	Units
8 x 8 x 0.9mm QFN	16	4.5	98.0	16.4 (3.0/-0.2)	19.1	mm

16.4 Moisture Sensitivity Level

RoadTunes ROM QFN Automotive is qualified to moisture sensitivity level MSL3 in accordance with JEDEC J-STD-020.

17 Ordering Information

Device	Package			Order Number
	Type	Size	Shipment Method	
RoadTunes ROM QFN Automotive	QFN 68-lead (Pb free)	8 x 8 x 0.9mm, 0.4mm pitch	Tape and Reel	BC57K687A07-IQF-E4

Note:

Until BC57K687A07-IQF reaches **Production** status, engineering samples order number applies. This is BC57K687A07-ES-IQF, with no minimum order quantity.

RoadTunes ROM QFN Automotive is a ROM-based device where the product code has the form BC57F687Axx. xx is the specific ROM-variant, 07 is the ROM-variant for RoadTunes ROM Solution.

At **Production** status **Minimum Order Quantity** is 2kpcs taped and reeled.

To contact a CSR representative, email sales@csr.com or go to www.csr.com/contacts

17.1 RoadTunes ROM Development Kit Ordering Information

Description	Order Number
RoadTunes ROM Development Kit example design	DEV-RR-CT-SDK-01A

深圳市城至微科技有限公司
 电话: 0755-83378582
 手机: 13510662515
<http://www.czwtech.com>

18 Document References

Document	Reference, Date
<i>BlueCore5 Charger Description and Calibration Procedure Application Note</i>	CS-113282-ANP
<i>BlueCore5-Multimedia External Recommendations for ESD Protection</i>	CS-114058-ANP
<i>BlueCore5-Multimedia RoadTunes Message Interface Guide</i>	CS-113414-UGP
<i>Bluetooth and IEEE 802.11 b/g Co-existence Solutions Overview</i>	CS-101409-ANP
<i>Core Specification of the Bluetooth System</i>	v2.0 + EDR
<i>IC Packing and Labelling Specification</i>	CS-112584-SPP
<i>Moisture / Reflow Sensitivity Classification for Nonhermitic Solid State Surface Mount Devices</i>	IPC / JEDEC J-STD-020
<i>Optimising BlueCore5-Multimedia ADC Performance Application Note</i>	CS-120059-AN
<i>RoadTunes ROM QFN Automotive Performance Specification</i>	CS-125444-SPP
<i>RoadTunes ROM Software Release Note</i>	CS-123181-RNP
<i>Selection of μC EEPROMS for Use with BlueCore</i>	CS-101518-ANP
<i>Test Suite Structure (TSS) and Test Purposes (TP) System Specification 1.2/2.0/2.0 + EDR/ 2.1/2.1 + EDR</i>	RF.TS/2.1.E.0, 2006
<i>Typical Solder Reflow Profile for Lead-free Devices</i>	CS-116434-ANP

Terms and Definitions

Term	Definition
8DPSK	8 phase Differential Phase Shift Keying
$\pi/4$ DQPSK	$\pi/4$ rotated Differential Quaternary Phase Shift Keying
A-law	Audio companding standard (G.711)
A2DP	Advanced Audio Distribution Profile
ADC	Analogue to Digital Converter
AFH	Adaptive Frequency Hopping
AGC	Automatic Gain Control
AVRCP	Audio/Video Remote Control Profile
BlueCore®	Group term for CSR's range of Bluetooth wireless technology ICs
BMC	Burst Mode Controller
codec	Coder decoder
CRC	Cyclic Redundancy Check
CSR	Cambridge Silicon Radio
cVc	Clear Voice Capture
CVSD	Continuous Variable Slope Delta Modulation
DC	Direct Current
DSP	Digital Signal Processor
DUN	Dial-Up Networking
EDR	Enhanced Data Rate
eSCO	Extended SCO
ESR	Equivalent Series Resistance
FEC	Forward Error Correction
FSK	Frequency Shift Keying
GFSK	Gaussian Frequency Shift Keying
GSM	Global System for Mobile communications
HEC	Header Error Check Correction
HFP	Hands-Free Profile
IIR	Infinite Impulse Response (filter)
IQ	In-Phase and Quadrature
I/O	Input/Output
IF	Intermediate Frequency
LC	An inductor (L) and capacitor (C) network
LNA	Low Noise Amplifier
MAC	Medium Access Control
MCU	MicroController Unit
MIPS	Million Instructions Per Second
MMU	Memory Management Unit
NSMD	Non Solder Mask Defined
PA	Power Amplifier
PBAP	Phonebook Access Profile
PIO	Programmable Input/Output

Term	Definition
QFN	Quad-Flat No-lead
RAM	Random Access Memory
RF	Radio Frequency
RISC	Reduced Instruction Set Computer
RSSI	Received Signal Strength Indication
SBC	Sub-band Coding
SPP	Serial Port Profile
UART	Universal Asynchronous Receiver Transmitter
VCO	Voltage Controlled Oscillator
VM	Virtual Machine
W-CDMA	Wideband Code Division Multiple Access

深圳市诚至微科技有限公司
电话：0755-83328582
手机：13510662515
<http://www.czwtech.com>