

# INFORMATION

**MODEL :** FC-135  
32.768 kHz

**INFO. No. :** 3A

**DATE :** Jan. 6. 2006

**EPSON TOYOCOM CORPORATION**

8548 Naka-minowa  
Minowa-machi Kamiina-gun  
Nagano-ken  
399-4696 Japan

深圳港中兴电子有限公司

#### INTRODUCTION

1. The contents is subject to change without notice.  
Please exchange the specification sheets regarding the product's warranty.
2. This sheet is not intended to guarantee or provide an approval of implementation of industrial patents.
3. We have prepared this sheet as carefully as possible.  
If you find it incomplete or unsatisfactory in any respect, We would welcome your comments.

This product is not authorized for use as critical components in life support device or systems.

## Contents

Item No.	Item	Page
[ 1 ]	Absolute maximum ratings	2
[ 2 ]	Operating range	2
[ 3 ]	Static characteristics	2
[ 4 ]	Environmental and Mechanical characteristics	3 to 4
[ 5 ]	Dimensions and Marking layout	5 to 6
[ 6 ]	Notes	7

[ 1 ] Absolute maximum ratings

Item	Symbol	Rating value
Storage temperature	TSTG	-55°C to +125°C
Maximum drive level	DL	1.0 μW

[ 2 ] Operating range

Item	Symbol	Value		
		Min.	Typ.	Max.
Operating temperature range	TOPR	-40°C		+85°C
Drive level	DL	0.01 μW	0.1 μW	0.5 μW
Vibration mode		Fundamental		

[ 3 ] Static characteristics

Item	Symbol	Value	Note
Frequency	f <sub>i</sub>	32,768 kHz	
Frequency tolerance	Δ f/f	± 20 × 10 <sup>-6</sup>	CL = 9 pF , 12.5 pF Ta = +25 ± 3°C, Drive level : 0.1 μW Not include aging
Series resistance	R <sub>1</sub>	70 kΩ Max.	CI meter : Saunders 140B Drive level : 0.5 μW
Motional capacitance	C <sub>1</sub>	Typ. 3.4 fF	
Shunt capacitance	C <sub>0</sub>	Typ. 1.2 pF	
Turnover temperature	θT	+25 ± 5 °C	Values are calculated by the frequencies at +10, +25, +40°C with C-MOS circuit.
Temperature coefficient	a	-4.0 × 10 <sup>-8</sup> /°C <sup>2</sup> Max.	
Isolation resistance	IR	500 MΩ Min.	DC 100V, 60 seconds Between terminal #1 and terminal #2
Aging	f <sub>a</sub>	± 3 × 10 <sup>-6</sup> / year	Ta = +25 °C ± 3 °C Drive level : 0.1 μW

#### [ 4 ] Environmental and Mechanical characteristics

No.	Items	Value	Conditions
1	Shock resistance	*3Δ f/f : ± 8 × 10 <sup>-6</sup>	100g dummy(SEIKO EPSON Standard), Natural drop from 1 500 mm height on to the concrete. 3 directions × 10 times *2
2	Vibration resistance	*3Δ f/f : ± 3 × 10 <sup>-6</sup>	10 Hz to 55 Hz amplitude 0.75 mm 55 Hz to 500 Hz acceleration 98 m/s <sup>2</sup> 10 Hz → 500 Hz → 10 Hz 15 min./cycle 6 h (2 hours , 3 directions) *2
3	Soldering heat resistance	Δ f/f : ± 5 × 10 <sup>-6</sup>	For convention reflow soldering furnace (2 times)
4	High temperature storage	*3Δ f/f : ± 10 × 10 <sup>-6</sup>	+125 °C × 1000 h *1
		*3Δ f/f : ± 7 × 10 <sup>-6</sup>	+85°C × 1000 h *1
5	Low temperature storage	*3Δ f/f : ± 10 × 10 <sup>-6</sup>	-55 °C × 1000 h *1
6	High temperature and humidity	*3Δ f/f : ± 10 × 10 <sup>-6</sup>	+85°C × 85%RH × 1000 h *1
7	Temperature cycle	*3Δ f/f : ± 10 × 10 <sup>-6</sup>	-55 °C ↔ +125°C 30 minutes at each temperature × 100 cycles *1
8	Sealing	*3 1 × 10 <sup>-3</sup> hPa·l / s Max.	For He leak detector
9	Shear	No peeling-off at a soldered part	20 N press for 10 ± 1 s. Ref. IEC 60068-2-21
10	Pull - off	No peeling-off at a soldered part	20 N press for 10 ± 1 s. Ref. IEC 60068-2-21
11	Substrate bending	No peeling-off at a soldered part	Bend width reaches 3 mm and hold for 5 s ± 1 s × 1 time Ref. IEC 60068-2-21
12	Solvent resistance	The marking shall be legible	Ref. JIS C 0052 or IEC 60068-2-45

#### < Notes >

- \*1 Each test done independently.
- \*2 Measuring 2 h to 24 h later leaving in room temperature after each test. Drive level : 0.5 μW
- \*3 Pre conditionings( Treat the Reflow 2 times with the following profile) Initial value shall be after 24 h at room temperature.

Shift of series resistance at before and after the test should be less than ±20 % or less than ±15kΩ.

In case high temperature storage(+125°C × 1 000 h), Soldering heat resistance, shift of series resistance at before and after the test should be less than ±30 % or ±20 kΩ.

◆ Air-reflow

Pre heating temperature: +170 [°C]  
Heating temperature : +220 [°C]

Pre heating time: 100 [s]  
Heating time : 30 [s]

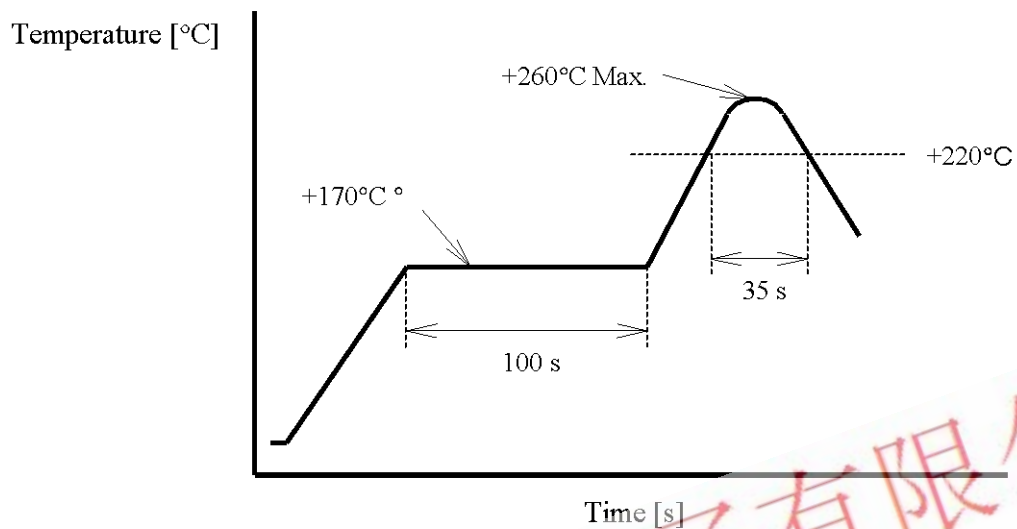

深圳港中兴电子有限公司

## [ 5 ] Dimensions and Marking layout

### 1. Dimensions

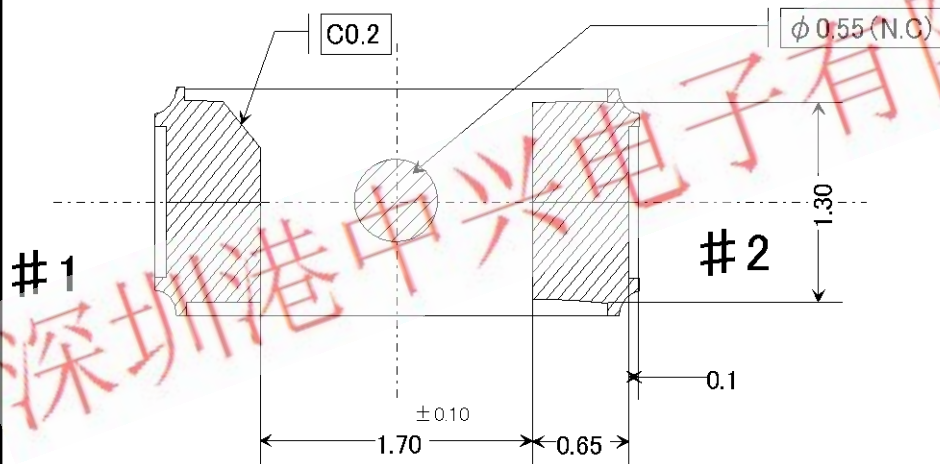
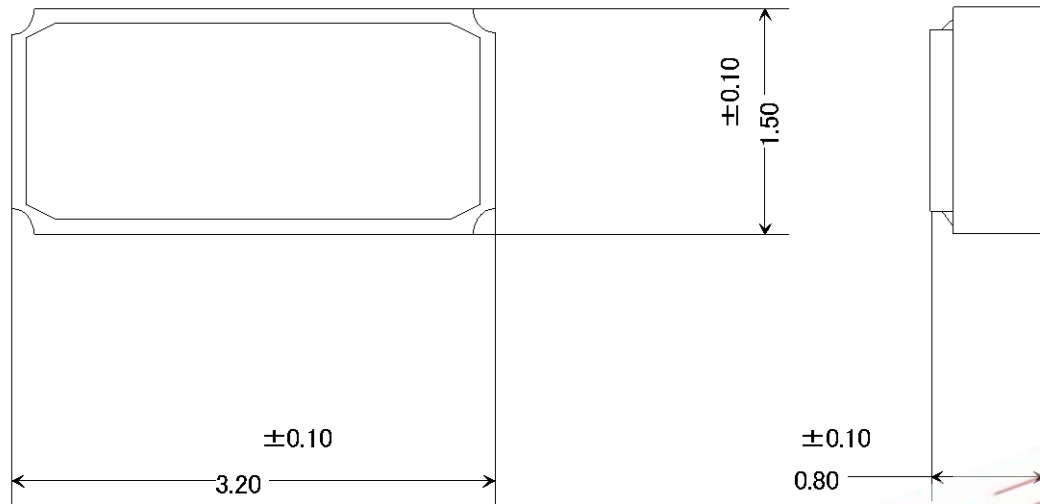

### 2. Internal Connection

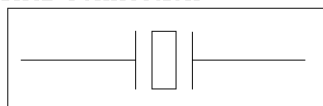

#1

#2

Package : Ceramic( $Al_2O_3$ )  
Terminal Au plate : 0.5  $\mu m$  Min.  
Lid : Glass

Type	FC-135	Terminal treatment	Au plating	Unit	1 = 1 mm
------	--------	--------------------	------------	------	----------

3. Recommended soldering pattern

Unit : 1 = 1 mm

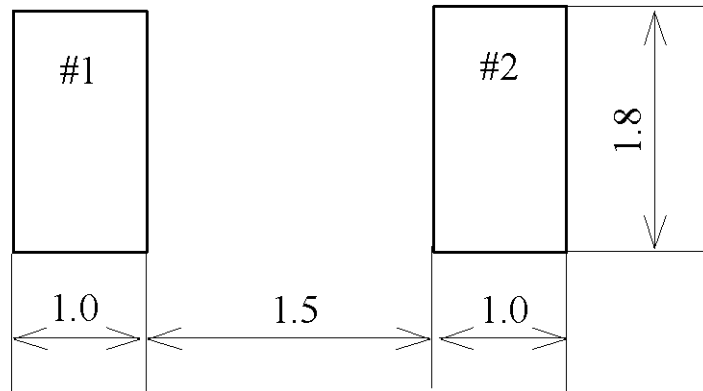

4. Marking layout

深圳港中兴电子有限公司

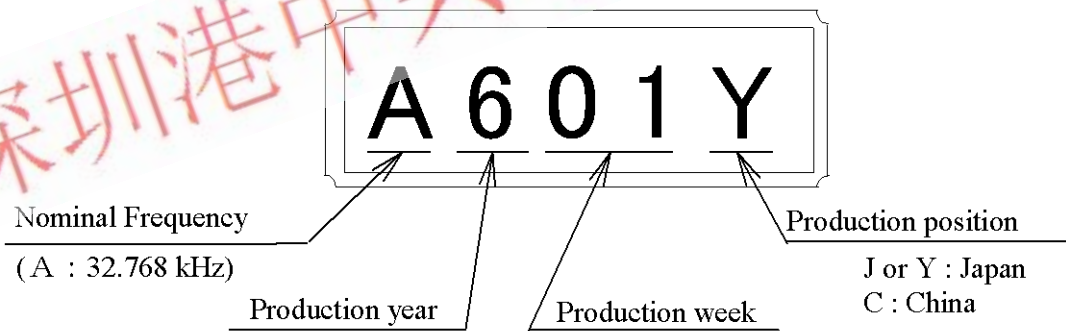

\* The above marking layout shows only marking contents and their approximate position and it is not for font, size and exact position.

Type	FC-135	Unit	1=1 mm
------	--------	------	--------



## [ 6 ] Notes

1. Max two (2) times reflow is allowed. Once miss soldering is happened, hand work soldering by soldering iron is recommended. (+350°C × within 5 s)
2. Patterning should be followed by our recommended one.
3. Applying excessive excitation force to the crystal resonator may cause deterioration damage.
4. Unless adequate negative resistance is allocated in the oscillation circuit, start up time of oscillation may be increased, or no oscillation may occur.

How to check the negative resistance.

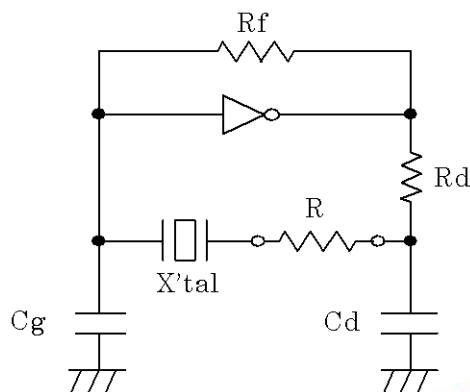

- (1) Connect the resistance (R) to the circuit in series with the crystal resonator.
- (2) Adjust R so that oscillation can start (or stop).
- (3) Measure R when oscillation just start (or stop) in above (2).
- (4) Get the negative resistance  
 $-R = R + CI$  value.
- (5) Recommended -R  
 $|-R| > CI \times (5 \sim 10)$

5. The shortest patterning line on board is recommendable.  
Too long line on board may cause of abnormal oscillation.
6. To avoid null function, no pattern under or near the crystal is allowed.  
Solder paste should be more than 150 μm thickness.
7. This device must be stored at the normal temperature and humidity conditions before mounting on a board.
8. Too much exciting shock or vibration may cause deterioration on damage.  
Depending on the condition such as a shock in assembly machinery, the products may be damaged.  
Please check your condition in advance to maintain shock level to be smallest.
9. Depending on the conditions, ultrasonic cleaning may cause resonant damage of the internal crystal resonator. Since we are unable to determine the conditions (type of cleaning unit, power, time, conditions inside the bath, etc.) to be used in your company, we cannot guarantee the safety of this unit when it is cleaned in an ultrasonic cleaner.
10. Ink marking may be damaged by some kind of solvent, please take precautions when choosing solvent by your selves.
11. Please refer to packing specification regarding how to storage the products in the pack.

[ 1 ] Taping specification

Subject to EIA-481 , EIAJ EDX7602 , IEC 60286 , and JIS C0806.

(1) Tape dimensions TE1204L

Material of the Carrier Tape : PS

Material of the Top Tape : PET+PE

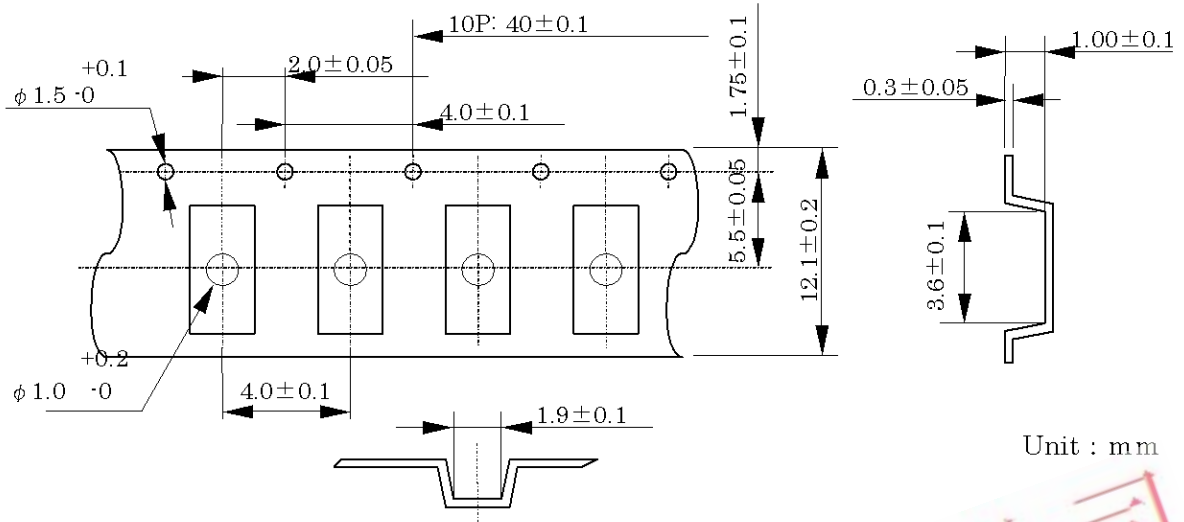

Unit : mm

(2) Reel dimensions EIAJRRM  $\phi 180$

Material of the Reel : PS

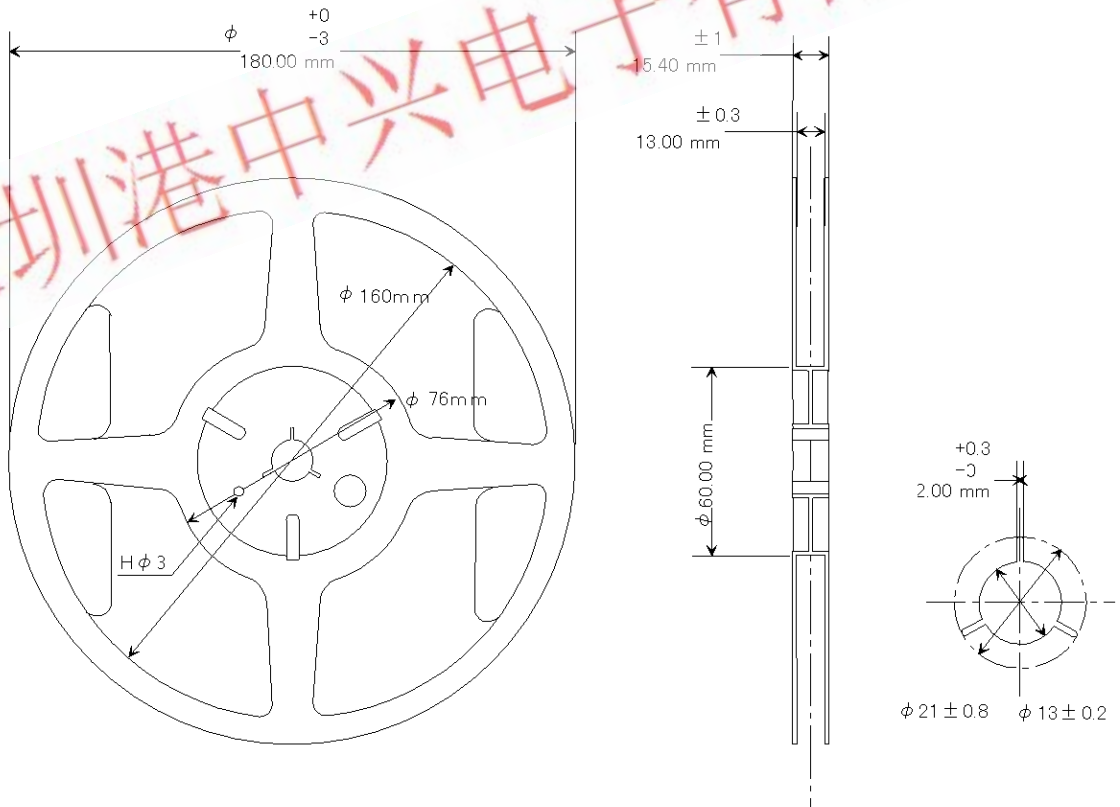

Form and Size of reel window shows are one of the example

(3) Packing

(a) Tape & Reel

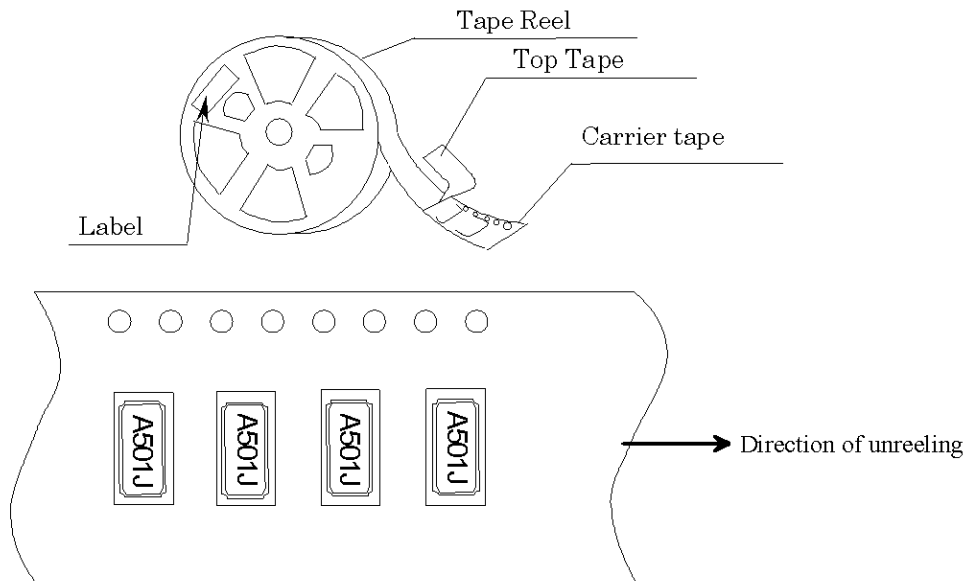

(b) Start & End Point

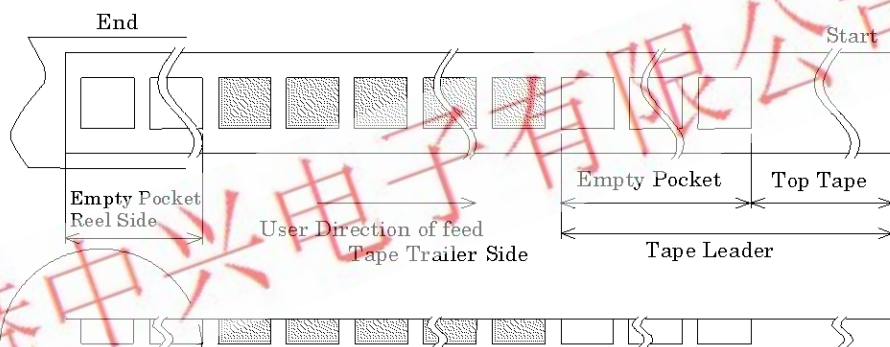

(c) Peel force of the cover tape

- (1) angle : cover tape during peel off and the direction of unreeling shall be 165° to 180°.
- (2) peel speed : 5 mm/s.

Item		Empty Space
Tape Leader	Top Tape	Min. 1 000 mm
	Carrier Tape	Min. 20 pockets
Tape Trailer	Top Tape	Min. 0 mm
	Carrier Tape	Min. 20 pockets

## [ 2 ] Inner Carton

### a) Packing to antistatic bag

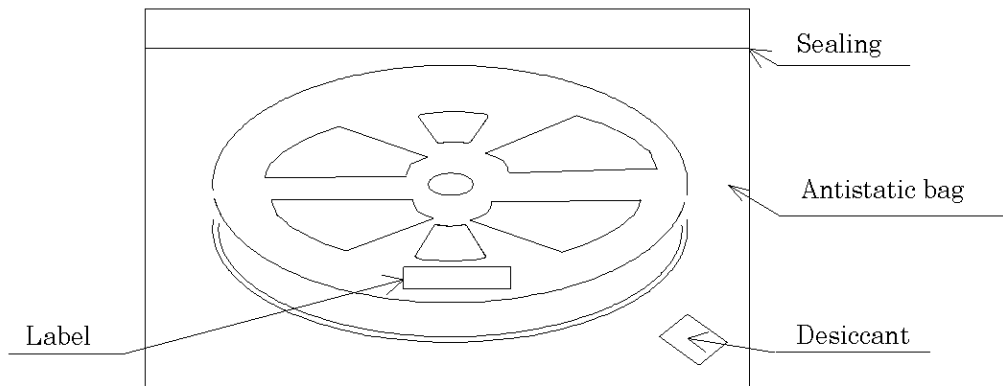

### b) Packing to innercarton

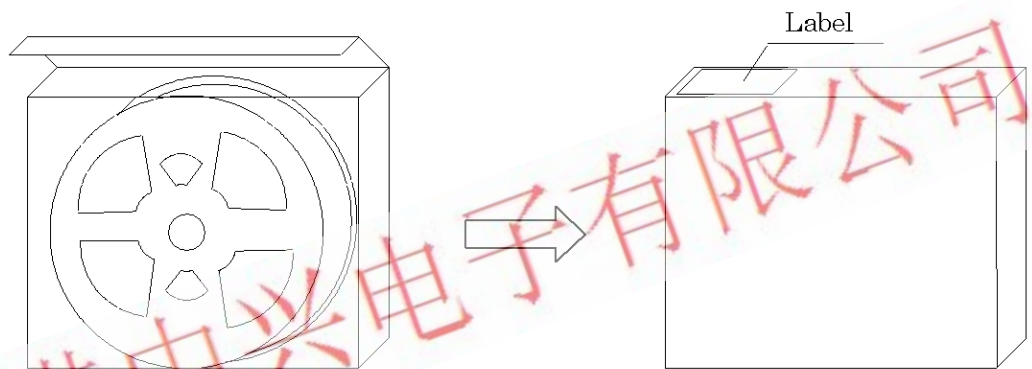

## [ 3 ] Shipping Carton

- Put inner boxes into an outer box.
- If there are room in the outer box, material is put in a shock absorbing together.

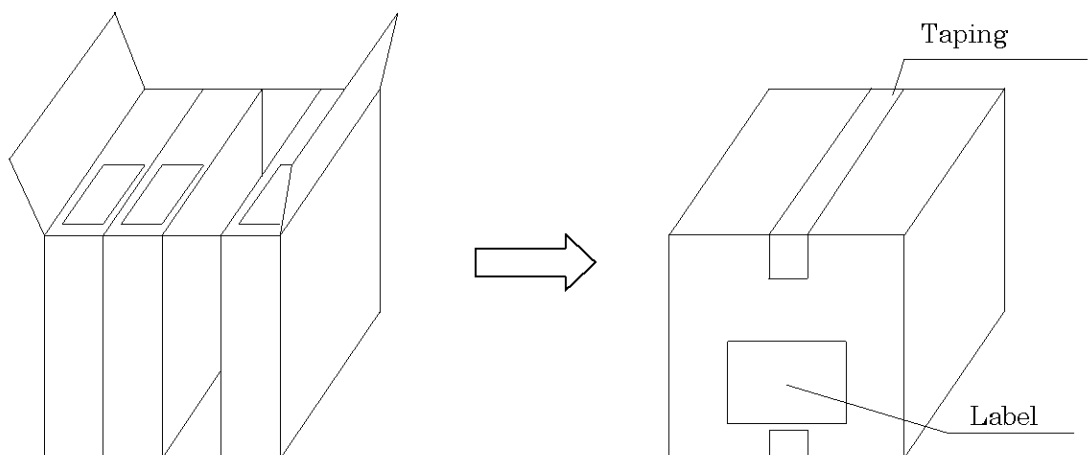

#### [ 4 ] Marking

(1) Reel marking

- Reel marking shall consist of :

- 1) Parts name
- 2) Quantity
- 3) Manufacturing Date or symbol
- 4) Manufacturer's Date or symbol
- 5) Others (if necessary)

(2) Inner carton marking

- Same as Reel marking.

(3) Shipping carton marking

- Shipping carton marking shall consist of :

- 1) Parts name
- 2) Quantity

#### [ 5 ] Quantity

- 3 000 pcs./reel

#### [ 6 ] Storage environment

- (1) To storage the reel at +15 °C to +35 °C, 25 %RH to 85 %RH of Humidity.
- (2) To open the packing just before using.
- (3) Not to expose the sun.
- (4) Not to storage with some erosive chemicals.
- (5) Nothing is allowed to put on the reel or carton to prevent mechanical damage.

#### [ 7 ] Handling

To handle with care to prevent the damage of tape, reel and products.