

### Features

- Schottky Barrier Chip
- High Thermal Reliability
- Patented Super Barrier Rectifier Technology
- High Forward Surge Capability
- Ultra Low Power Loss, High Efficiency
- Excellent High Temperature Stability
- Plastic material-UL flammability 94V-0

### Mechanical Data

- Case: TO-277, molded plastic
- Terminals: Plated Leads Solderable per MIL-STD-202, Method 208
- Polarity: Cathode Band
- Mounting Position: Any
- Marking: Type Number
- Lead Free: For RoHS/Lead Free Version

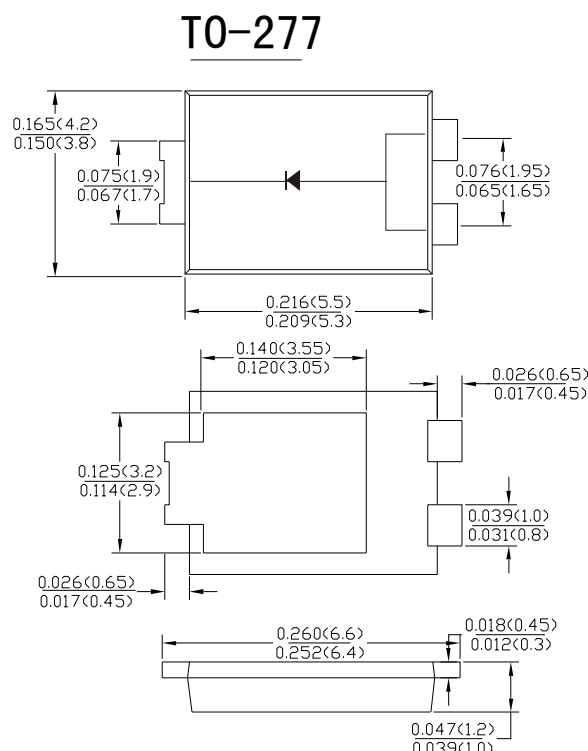

Dimensions inches and (milimeters)

### Maximum Ratings and Electrical Characteristics @ $T_A = 25^\circ\text{C}$ unless otherwise specified

Single Phase, half wave, 60Hz, resistive or inductive load. For capacitive load, derate current by 20%.

Parameter	Symbol	SL15T100	Unit
Maximum repetitive peak reverse voltage	$V_{RRM}$	100	V
Maximum rms voltage	$V_{RMS}$	70	V
Working Peak Reverse Voltage	$V_{RWM}$	100	V
Maximum dc blocking voltage	$V_R$	100	V
Maximum average forward rectified current	$I_{F(AV)}$	15	A
Peak forward surge current : 8.3ms single half sine-wave superimposed on rated load	$I_{FSM}$	250	A
Peak Repetitive Reverse Current at $t_p=2\ \mu\text{s}$ , 1kHz	$I_{RRM}$	1.0	A
Typical thermal resistance (Note 1)	$R_{\theta JA}$	110	$^\circ\text{C/W}$
(Note 2)	$R_{\theta JC}$	3	
Operating junction temperature range	$T_J$	-65 to +150	$^\circ\text{C}$
storage temperature range	$T_{STG}$	-65 to +175	$^\circ\text{C}$

Note : 1. Mounted on a FR4 PCB, single-sided copper, mini pad.

2. Mounted on a 10cm\*10cm\*1mm copper pad area

### ELECTRICAL CHARACTERISTICS (T<sub>A</sub>=25°C unless otherwise noted)

PARAMETER	SYMBOL	TEST CONDITIONS	MIN.	TYP.	MAX.	UNIT
Instantaneous forward voltage	V <sub>F</sub>	I <sub>F</sub> =10A I <sub>F</sub> =15A T <sub>J</sub> =25°C	-	0.57 0.65	- 0.73	V
		I <sub>F</sub> =10A I <sub>F</sub> =15A T <sub>J</sub> =125°C	-	0.53 0.60	- 0.65	V
Reverse current	I <sub>R</sub>	V <sub>R</sub> =100V T <sub>J</sub> =25°C T <sub>J</sub> =125°C	-	25	180	μA
			-	15	30	mA

Fig.1 Forward Current Derating Curve

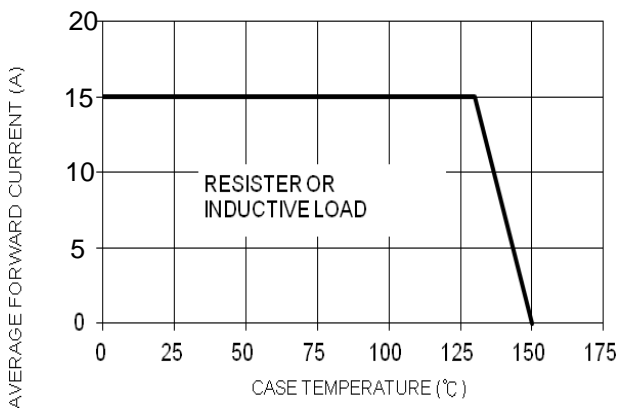

Fig.2 Typical Junction Capacitance

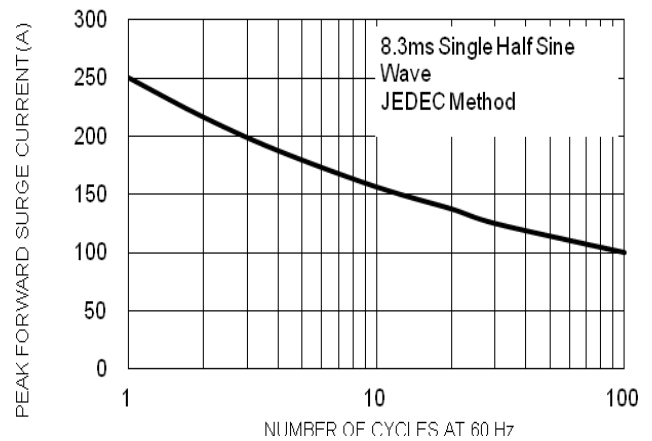

Fig.3 Typical Reverse Characteristics

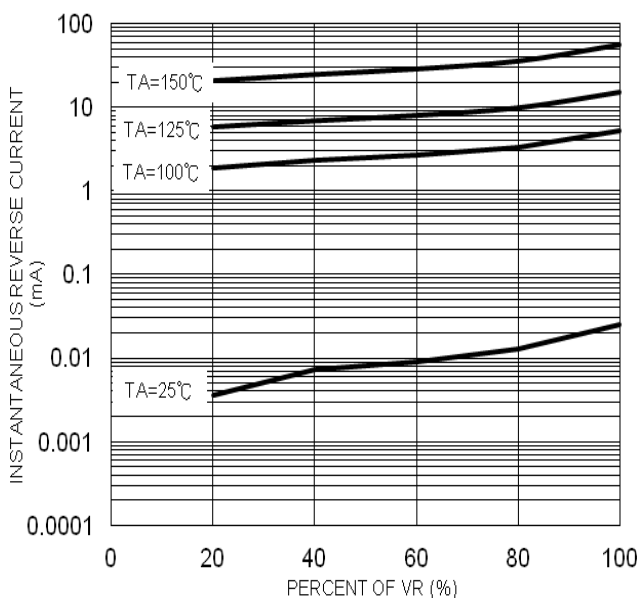

Fig.4 Typical Forward Characteristics

