

30V Dual P-Channel Enhancement Mode MOSFET

VDS= -30V

RDS(ON), Vgs @-10V, Ids @-4.5A = 63mΩ

RDS(ON), Vgs @-4.5V, Ids @-3.6A = 90mΩ

Features

Advanced trench process technology

High Density Cell Design For Ultra Low On-Resistance

Improved Shoot-Through FOM

Package Dimensions

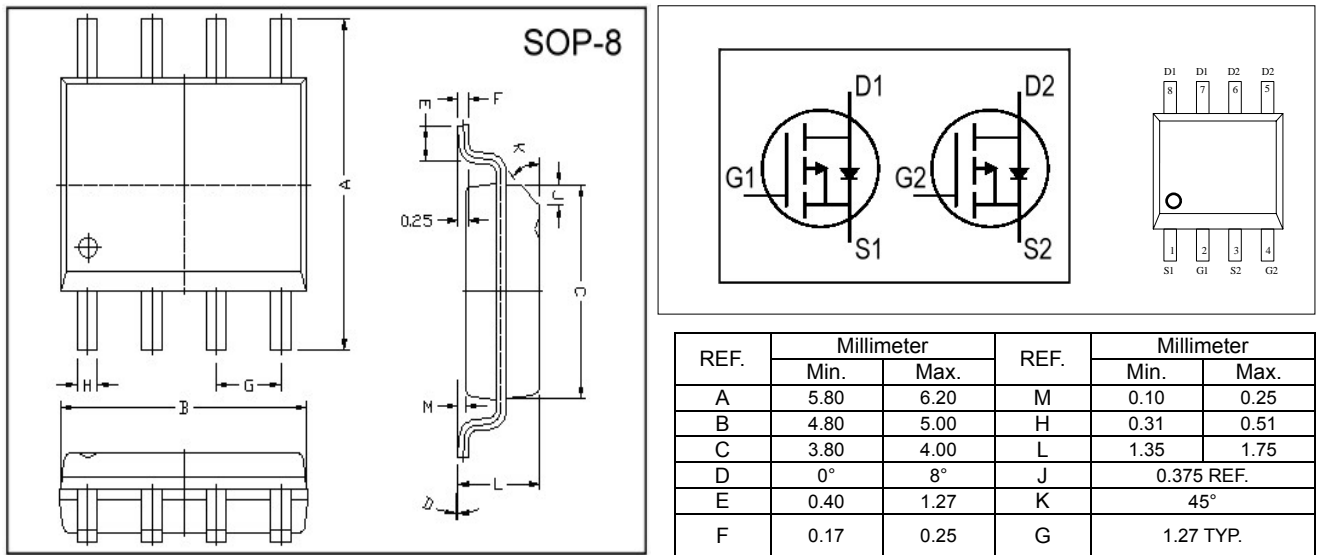

Maximum Ratings and Thermal Characteristics (TA = 25oC unless otherwise noted)

Parameter	Symbol	Limit	Unit	
Drain-Source Voltage	V _{DS}	-30	V	
Gate-Source Voltage	V _{GS}	± 20		
Continuous Drain Current	I _D	-5.3	A	
Pulsed Drain Current ¹⁾	I _{DM}	-20		
Maximum Power Dissipation	P _D	TA = 25°C	2.5	W
		TA = 75°C	1.2	
Operating Junction and Storage Temperature Range	T _J , T _{stg}	-55 to 150	°C	
Junction-to-Ambient Thermal Resistance (PCB mounted) ²⁾	R _{θJA}	62.5	°C/W	

Notes

1) Pulse width limited by maximum junction temperature.

2) Surface Mounted on FR4 Board, t ≤ 5 sec.

30V Dual P-Channel Enhancement Mode MOSFET

ELECTRICAL CHARACTERISTICS

Parameter	Symbol	Test Condition	Min.	Typ.	Max.	Unit
Static						
Drain-Source Breakdown Voltage	BV_{DSS}	$V_{GS} = 0V, I_D = -250\mu A$	-30			V
Drain-Source On-State Resistance	$R_{DS(on)}$	$V_{GS} = -4.5V, I_D = -3.6A$		70	90	m Ω
Drain-Source On-State Resistance	$R_{DS(on)}$	$V_{GS} = -10V, I_D = -4.5A$		50	63	
Gate Threshold Voltage	$V_{GS(th)}$	$V_{DS} = V_{GS}, I_D = -250\mu A$	-1	1.7	-3	V
Zero Gate Voltage Drain Current I_{DSS}	I_{DSS}	$V_{DS} = -24V, V_{GS} = 0V$			-1	μA
Gate Body Leakage	I_{GSS}	$V_{GS} = \pm 16V, V_{DS} = 0V$			± 100	nA
Forward Transconductance	g_{fs}	$V_{DS} = -10V, I_D = -5.3A$		10	—	S
Dynamic¹⁾						
Total Gate Charge	Q_g	$V_{DS} = -15V, I_D = -5.3A$ $V_{GS} = -10V$		28		nC
Gate-Source Charge	Q_{gs}			3		
Gate-Drain Charge	Q_{gd}			7		
Turn-On Delay Time	$t_{d(on)}$	$V_{DD} = -15V, R_L = 15\Omega$ $I_D = -1A, V_{GEN} = -10V$ $R_G = 6\Omega$		9		ns
Turn-On Rise Time	t_r			15		
Turn-Off Delay Time	$t_{d(off)}$			75		
Turn-Off Fall Time	t_f			40		
Input Capacitance	C_{iss}	$V_{DS} = -15V, V_{GS} = 0V$ $f = 1.0\text{ MHz}$		745		pF
Output Capacitance	C_{oss}			440		
Reverse Transfer Capacitance	C_{rss}			120		
Source-Drain Diode						
Max. Diode Forward Current	I_S				-2.6	A
Diode Forward Voltage	V_{SD}	$I_S = -2.6A, V_{GS} = 0V$			-1.3	V

1) Pulse test: pulse width $\leq 300\mu s$, duty cycle $\leq 2\%$

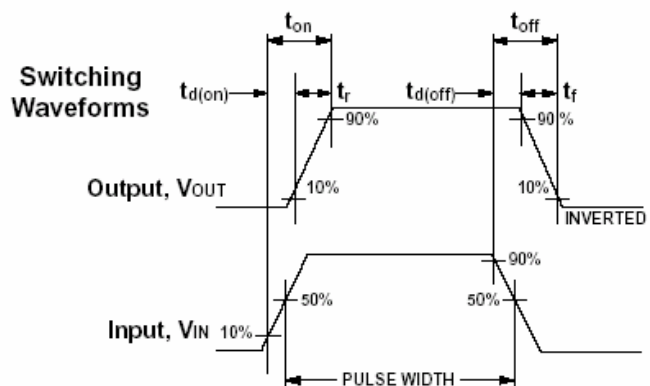
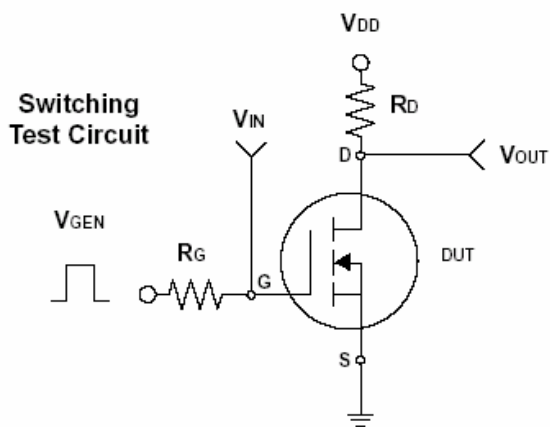

30V Dual P-Channel Enhancement Mode MOSFET

Typical Characteristics (T_J = 25°C Noted)

