



February 1988

CD4099BM/CD4099BC 8-Bit Addressable Latch

General Description

The CD4099B is an 8-bit addressable latch with three address inputs (A0–A2), an active low enable input (\bar{E}), active high clear input (CL), a data input (D), and eight outputs (Q0–Q7).

Data is entered into a particular bit in the latch when that bit is addressed by the address inputs and the enable (\bar{E}) is low. Data entry is inhibited when enable (\bar{E}) is high.

When clear (CL) and enable (\bar{E}) are high, all outputs are low. When clear (CL) is high and enable (\bar{E}) is low, the channel demultiplexing occurs. The bit that is addressed has an active output which follows the data input while all unaddressed bits are held low. When operating in the addressable latch mode ($\bar{E} = \text{CL} = \text{low}$), changing more than one bit of the address could impose a transient wrong address. Therefore, this should only be done while in the memory mode ($\bar{E} = \text{high}$, $\text{CL} = \text{low}$).

Features

- Wide supply voltage range 3.0V to 15V
- High noise immunity 0.45 V_{DD} (typ.)
- Low power TTL fan out of 2 driving 74L or 1 driving 74LS compatibility
- Serial to parallel capability
- Storage register capability
- Random (addressable) data entry
- Active high demultiplexing capability
- Common active high clear

Connection Diagram

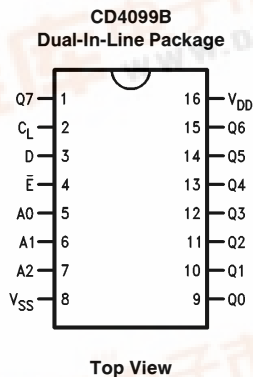

Order Number CD4099B

Truth Table

Mode Selection				
\bar{E}	CL	Addressed Latch	Unaddressed Latch	Mode
L	L	Follows Data	Holds Previous Data	Addressable Latch Memory Demultiplexer Clear
H	L	Holds Previous Data	Holds Previous Data	
L	H	Follows Data	Reset to "0"	
H	H	Reset to "0"	Reset to "0"	

CD4099BM/CD4099BC 8-Bit Addressable Latch



Absolute Maximum Ratings (Notes 1 & 2)

If Military/Aerospace specified devices are required, please contact the National Semiconductor Sales Office/Distributors for availability and specifications.

DC Supply Voltage (V_{DD})	-0.5 to +18 V_{DC}
Input Voltage (V_{IN})	-0.5 to V_{DD} + 0.5 V_{DC}
Storage Temperature Range (T_S)	-65°C to +150°C
Power Dissipation (P_D)	
Dual-In-Line	700 mW
Small Outline	500 mW
Lead Temperature (T_L)	
(Soldering, 10 seconds)	260°C

Recommended Operating Conditions (Note 2)

DC Supply Voltage (V_{DD})	3.0 to 15 V_{DC}
Input Voltage (V_{IN})	0 to V_{DD} V_{DC}
Operating Temperature Range (T_A)	
CD4099BM	-55°C to +125°C
CD4099BC	-40°C to +85°C

DC Electrical Characteristics CD4099BM (Note 2)

Symbol	Parameter	Conditions	-55°C		+25°C			+125°C		Units
			Min	Max	Min	Typ	Max	Min	Max	
I_{DD}	Quiescent Device Current	$V_{DD} = 5V, V_{IN} = V_{DD}$ or V_{SS}		5.0		0.02	5.0		150	μA
		$V_{DD} = 10V, V_{IN} = V_{DD}$ or V_{SS}		10		0.02	10		300	μA
		$V_{DD} = 15V, V_{IN} = V_{DD}$ or V_{SS}		20		0.02	20		600	μA
V_{OL}	Low Level Output Voltage	$ I_O \leq 1 \mu A$ $V_{DD} = 5V$		0.05		0	0.05		0.05	V
		$V_{DD} = 10V$		0.05		0	0.05		0.05	V
		$V_{DD} = 15V$		0.05		0	0.05		0.05	V
V_{OH}	High Level Output Voltage	$ I_O \leq 1 \mu A$ $V_{DD} = 5V$	4.95		4.95	5.0		4.95		V
		$V_{DD} = 10V$	9.95		9.95	10		9.95		V
		$V_{DD} = 15V$	14.95		14.95	15		14.95		V
V_{IL}	Low Level Input Voltage	$V_{DD} = 5V, V_O = 0.5V$ or 4.5V		1.5		2.25	1.5		1.5	V
		$V_{DD} = 10V, V_O = 1.0V$ or 9.0V		3.0		4.5	3.0		3.0	V
		$V_{DD} = 15V, V_O = 1.5V$ or 13.5V		4.0		6.75	4.0		4.0	V
V_{IH}	High Level Input Voltage	$V_{DD} = 5V, V_O = 0.5V$ or 4.5V	3.5		3.5	2.75		3.5		V
		$V_{DD} = 10V, V_O = 1.0V$ or 9.0V	7.0		7.0	5.5		7.0		V
		$V_{DD} = 15V, V_O = 1.5V$ or 13.5V	11.0		11.0	8.25		11.0		V
I_{OL}	Low Level Output Current (Note 3)	$V_{DD} = 5V, V_O = 0.4V$	0.64		0.51	0.88		0.36		mA
		$V_{DD} = 10V, V_O = 0.5V$	1.6		1.3	2.25		0.9		mA
		$V_{DD} = 15V, V_O = 1.5V$	4.2		3.4	8.8		2.4		mA
I_{OH}	High Level Output Current (Note 3)	$V_{DD} = 5V, V_O = 4.6V$	-0.64		-0.51	-0.88		-0.36		mA
		$V_{DD} = 10V, V_O = 9.5V$	-1.6		-1.3	-2.25		-0.9		mA
		$V_{DD} = 15V, V_O = 13.5V$	-4.2		-3.4	-8.8		-2.4		mA
I_{IN}	Input Current	$V_{DD} = 15V, V_{IN} = 0V$		-0.10		-10^{-5}	-0.10		-1.0	μA
		$V_{DD} = 15V, V_{IN} = 15V$		0.10		10^{-5}	0.10		1.0	μA

DC Electrical Characteristics CD4099BC (Note 2)

Symbol	Parameter	Conditions	-40°C		+25°C			+85°C		Units
			Min	Max	Min	Typ	Max	Min	Max	
I_{DD}	Quiescent Device Current	$V_{DD} = 5V, V_{IN} = V_{DD}$ or V_{SS}		20		0.02	20		150	μA
		$V_{DD} = 10V, V_{IN} = V_{DD}$ or V_{SS}		40		0.02	40		300	μA
		$V_{DD} = 15V, V_{IN} = V_{DD}$ or V_{SS}		80		0.02	80		600	μA
V_{OL}	Low Level Output Voltage	$ I_O \leq 1 \mu A$ $V_{DD} = 5V$		0.05		0	0.05		0.05	V
		$V_{DD} = 10V$		0.05		0	0.05		0.05	V
		$V_{DD} = 15V$		0.05		0	0.05		0.05	V
V_{OH}	High Level Output Voltage	$ I_O \leq 1 \mu A$ $V_{DD} = 5V$	4.95		4.95	5		4.95		V
		$V_{DD} = 10V$	9.95		9.95	10		9.95		V
		$V_{DD} = 15V$	14.95		14.95	15		14.95		V
V_{IL}	Low Level Input Voltage	$V_{DD} = 5V, V_O = 0.5V$ or 4.5V		1.5		2.25	1.5		1.5	V
		$V_{DD} = 10V, V_O = 1.0V$ or 9.0V		3.0		4.5	3.0		3.0	V
		$V_{DD} = 15V, V_O = 1.5V$ or 13.5V		4.0		6.75	4.0		4.0	V
V_{IH}	High Level Input Voltage	$V_{DD} = 5V, V_O = 0.5V$ or 4.5V	3.5		3.5	2.75		3.5		V
		$V_{DD} = 10V, V_O = 1.0V$ or 9.0V	7.0		7.0	5.5		7.0		V
		$V_{DD} = 15V, V_O = 1.5V$ or 13.5V	11.0		11.0	8.25		11.0		V

DC Electrical Characteristics CD4099BC (Note 2) (Continued)

Symbol	Parameter	Conditions	-40°C		+25°C			+85°C		Units
			Min	Max	Min	Typ	Max	Min	Max	
I _{OL}	Low Level Output Current (Note 3)	V _{DD} = 5V, V _O = 0.4V	0.52		0.44	0.88		0.36		mA
		V _{DD} = 10V, V _O = 0.5V	1.3		1.1	2.25		0.9		mA
		V _{DD} = 15V, V _O = 1.5V	3.6		3.0	8.8		2.4		mA
I _{OH}	High Level Output Current (Note 3)	V _{DD} = 5V, V _O = 4.6V	-0.52		-0.44	-0.88		-0.36		mA
		V _{DD} = 10V, V _O = 9.5V	-1.3		-1.1	-2.25		-0.9		mA
		V _{DD} = 15V, V _O = 13.5V	-3.6		-3.0	-8.8		-2.4		mA
I _{IN}	Input Current	V _{DD} = 15V, V _{IN} = 0V V _{DD} = 15V, V _{IN} = 15V		-0.30 0.30		-10 ⁻⁵ 10 ⁻⁵	-0.30 0.30		-1.0 1.0	μA μA

AC Electrical Characteristics*

T_A = 25°C, C_L = 50 pF, R_L = 200k, Input t_r = t_f = 20 ns, unless otherwise noted

Symbol	Parameter	Conditions	Min	Typ	Max	Units
t _{PHL} , t _{PLH}	Propagation Delay Data to Output	V _{DD} = 5V		200	400	ns
		V _{DD} = 10V		75	150	ns
		V _{DD} = 15V		50	100	ns
t _{PLH} , t _{PHL}	Propagation Delay Enable to Output	V _{DD} = 5V		200	400	ns
		V _{DD} = 10V		80	160	ns
		V _{DD} = 15V		60	120	ns
t _{PHL}	Propagation Delay Clear to Output	V _{DD} = 5V		175	350	ns
		V _{DD} = 10V		80	160	ns
		V _{DD} = 15V		65	130	ns
t _{TLH} , t _{THL}	Propagation Delay Address to Output	V _{DD} = 5V		225	450	ns
		V _{DD} = 10V		100	200	ns
		V _{DD} = 15V		75	150	ns
t _{THL} , t _{TLH}	Transition Time (Any Output)	V _{DD} = 5V		100	200	ns
		V _{DD} = 10V		50	100	ns
		V _{DD} = 15V		40	80	ns
T _{WH} , T _{WL}	Minimum Data Pulse Width	V _{DD} = 5V		100	200	ns
		V _{DD} = 10V		50	100	ns
		V _{DD} = 15V		40	80	ns
t _{WH} , t _{WL}	Minimum Address Pulse Width	V _{DD} = 5V		200	400	ns
		V _{DD} = 10V		100	200	ns
		V _{DD} = 15V		65	125	ns
t _{WH}	Minimum Clear Pulse Width	V _{DD} = 5V		75	150	ns
		V _{DD} = 10V		40	75	ns
		V _{DD} = 15V		25	50	ns
t _{SU}	Minimum Set-Up Time Data to E	V _{DD} = 5V		40	80	ns
		V _{DD} = 10V		20	40	ns
		V _{DD} = 15V		15	30	ns
t _H	Minimum Hold Time Data to E	V _{DD} = 5V		60	120	ns
		V _{DD} = 10V		30	60	ns
		V _{DD} = 15V		25	50	ns
t _{SU}	Minimum Set-Up Time Address to E	V _{DD} = 5V		-15	50	ns
		V _{DD} = 10V		0	30	ns
		V _{DD} = 15V		0	20	ns
t _H	Minimum Hold Time Address to E	V _{DD} = 5V		-50	15	ns
		V _{DD} = 10V		-20	10	ns
		V _{DD} = 15V		-15	5	ns
C _{PD}	Power Dissipation Capacitance	Per Package (Note 4)		100		pF
C _{IN}	Input Capacitance	Any Input		5.0	7.5	pF

*AC Parameters are guaranteed by DC correlated testing.

Note 1: "Absolute Maximum Ratings" are those values beyond which the safety of the device cannot be guaranteed; they are not meant to imply that the devices should be operated at these limits. The tables of "Recommended Operating Conditions" and "Electrical Characteristics" provide conditions for actual device operation.

Note 2: V_{SS} = 0V unless otherwise specified.

Note 3: I_{OH} and I_{OL} are tested one output at a time.

Note 4: Dynamic power dissipation (P_D) is given by: P_D = (C_{PD} + C_L) V_{CC}²f + P_Q; where C_L = load capacitance; f = frequency of operation; for further details, see application note AN-90, "54C/74C Family Characteristics".

Logic Diagram

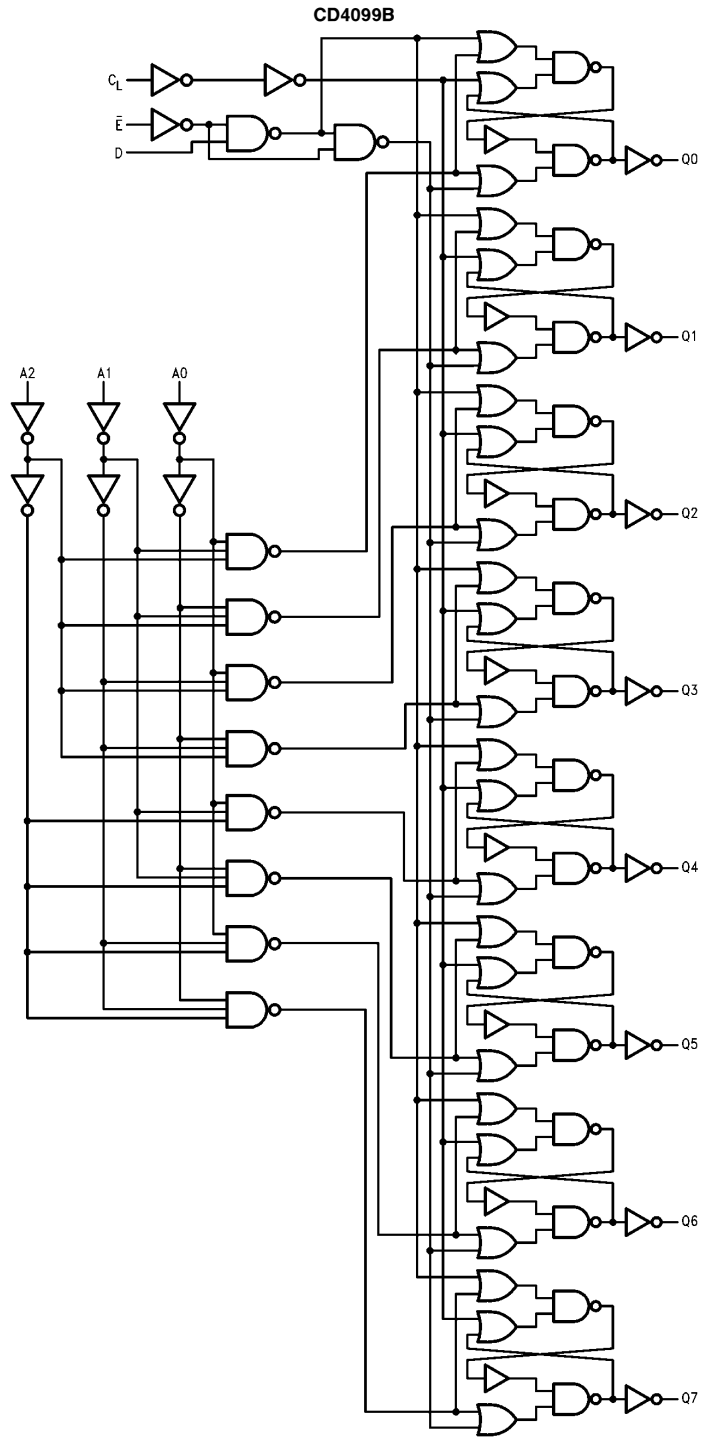

TL/F/5984-2

Switching Time Waveforms

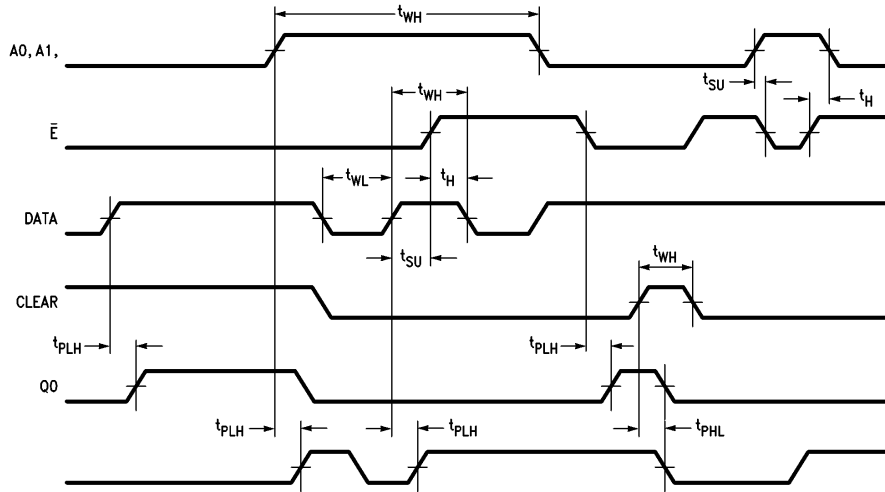

TL/F/5984-3

Physical Dimensions inches (millimeters)

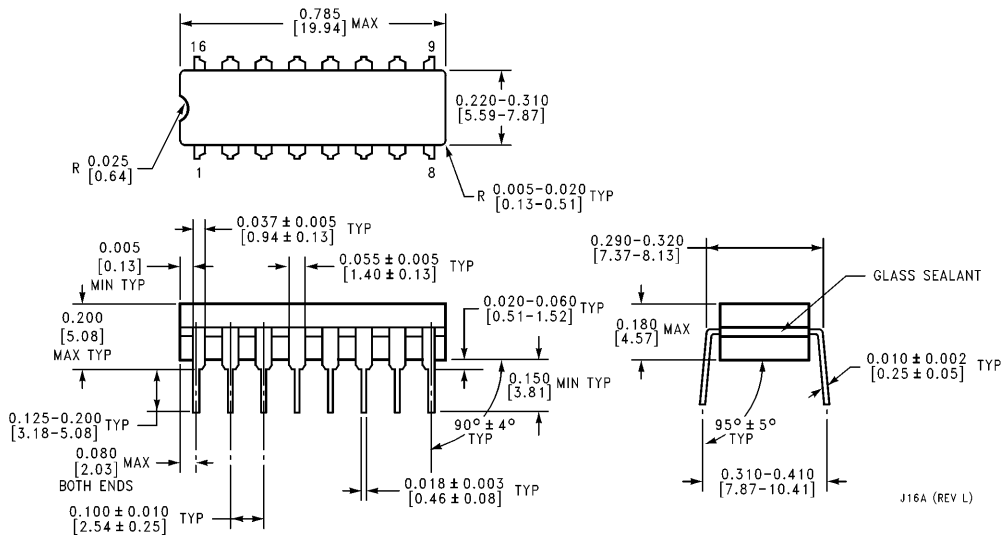

Ceramic Dual-In-Line Package (J)
Order Number CD4099BMJ or CD4099BCJ
NS Package Number J16A

J16A (REV L)

Physical Dimensions inches (millimeters) (Continued)

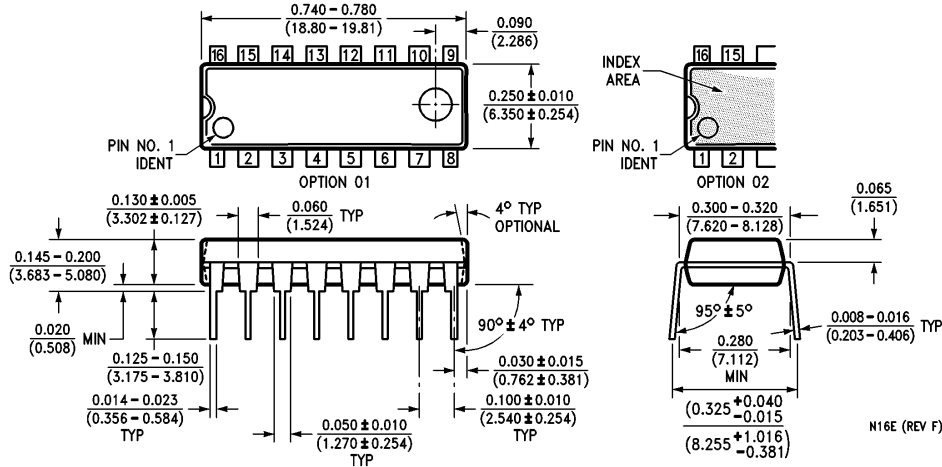

Molded Dual-In-Line Package (N)
Order Number CD4099BMN or CD4099BCN
NS Package Number N16E

LIFE SUPPORT POLICY

NATIONAL'S PRODUCTS ARE NOT AUTHORIZED FOR USE AS CRITICAL COMPONENTS IN LIFE SUPPORT DEVICES OR SYSTEMS WITHOUT THE EXPRESS WRITTEN APPROVAL OF THE PRESIDENT OF NATIONAL SEMICONDUCTOR CORPORATION. As used herein:

1. Life support devices or systems are devices or systems which, (a) are intended for surgical implant into the body, or (b) support or sustain life, and whose failure to perform, when properly used in accordance with instructions for use provided in the labeling, can be reasonably expected to result in a significant injury to the user.
2. A critical component is any component of a life support device or system whose failure to perform can be reasonably expected to cause the failure of the life support device or system, or to affect its safety or effectiveness.



National Semiconductor Corporation
 1111 West Bardin Road
 Arlington, TX 76017
 Tel: 1(800) 272-9959
 Fax: 1(800) 737-7018

National Semiconductor Europe
 Fax: (+49) 0-180-530 85 86
 Email: cnjwge@tevm2.nsc.com
 Deutsch Tel: (+49) 0-180-530 85 85
 English Tel: (+49) 0-180-532 78 32
 Français Tel: (+49) 0-180-532 93 58
 Italiano Tel: (+49) 0-180-534 16 80

National Semiconductor Hong Kong Ltd.
 13th Floor, Straight Block,
 Ocean Centre, 5 Canton Rd.
 Tsimshatsui, Kowloon
 Hong Kong
 Tel: (852) 2737-1600
 Fax: (852) 2736-9960

National Semiconductor Japan Ltd.
 Tel: 81-043-299-2309
 Fax: 81-043-299-2408