



**MOTOROLA**

# Automotive Half-Amp High-Side Switch

The MC3399 is a High-Side Switch designed to drive loads from the positive side of the power supply. The output is controlled by a TTL compatible input Enable pin. In the "on" state, the device exhibits very low saturation voltages for load currents in excess of 750 mA. The device isolates the load from positive or negative going high voltage transients by abruptly "opening" thus protecting the load from the transient voltage for the duration of the transient. The device automatically re-establishes its original operating state following the transient condition.

The MC3399 is fabricated on a power BIMOS process which combines the best features of Bipolar and MOS technologies. The mixed technology provides higher gain PNP output devices and results in Power Integrated Circuits having substantially reduced quiescent currents.

The device operates over a wide power supply voltage range and can withstand voltage transients (positive or negative) of  $\pm 100$  V. A rugged PNP output stage along with active clamp circuitry, output current limit and thermal shutdown permit the driving of all types of loads, including inductive. The MC3399 is offered in 5-lead TO-220 and 16-lead SOIC plastic packages to facilitate either "thru-hole" or surface mount use. In addition, it is specified over a wide ambient operating temperature of  $-40^{\circ}\text{C}$  to  $+125^{\circ}\text{C}$  and is ideally suited for industrial and automotive applications where harsh environments exist.

- Low Switch Voltage Drop
- Load Currents in Excess of 750 mA
- Low Quiescent Current
- Transient Protection Up to  $\pm 100$  V
- TTL Compatible Enable Input
- On-Chip Current Limit and Thermal Shutdown Circuitry

## Representative Block Diagram

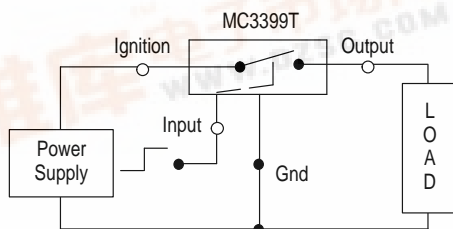

This device contains 52 active transistors.

# MC3399

## AUTOMOTIVE HALF-AMP HIGH-SIDE SWITCH

### SEMICONDUCTOR TECHNICAL DATA

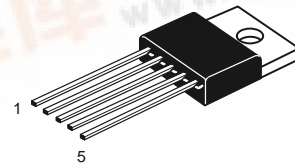

- Pin
1. Ignition
  2. Output
  3. Output
  4. Ground
  5. Input

**T SUFFIX**  
PLASTIC PACKAGE  
CASE 314D

Pins 2 and 3 connected to package tab.

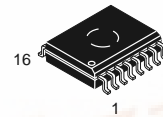

- Pin
1. Ignition
  2. N.C.
  3. N.C.
  4. N.C.
  5. Ground
  6. N.C.
  7. Input
  8. N.C.
  9. Output
  10. Output
  11. Output
  12. Output
  13. Output
  14. Output
  15. Output
  16. Output

**DW SUFFIX**  
PLASTIC PACKAGE  
CASE 751G  
SOP(8+8)L

## ORDERING INFORMATION

Device	Operating Temperature Range	Package
MC3399DW	$T_A = -40^{\circ}$ to $+125^{\circ}\text{C}$	SOP(8+8)L
MC3399T		Plastic Power

# MC3399

## MAXIMUM RATINGS

Rating	Symbol	Value	Unit
Ignition Input Voltage (Continuous) Forward Reverse	$V_{IGN}$	25 -16	Vdc
Ignition Input Voltage (Transient)	$V_{IGN}$	$\pm 60$ $\pm 100$	V
Input Voltage	$V_{in}$	-0.3 to +7.0	V
Output Current	$I_O$	Internally Limited	A
Thermal Resistance Plastic Power Package (Case 314D) Junction-to-Ambient Junction-to-Tab SOP(8+8)L Plastic Package (Case 751G) Junction-to-Ambient Junction-to-Lead 12	$R_{\theta JA1}$ $R_{\theta JT}$ $R_{\theta JA2}$ $R_{\theta JL}$	65 5.0 138 52	$^{\circ}\text{C}/\text{W}$
Soldering Temperature (for 10 Seconds)	$T_{solder}$	260	$^{\circ}\text{C}$
Junction Temperature	$T_J$	-40 to +150	$^{\circ}\text{C}$
Storage Temperature	$T_{stg}$	-65 to +150	$^{\circ}\text{C}$

## ELECTRICAL CHARACTERISTICS ( $V_{IGN} = 12\text{ V}$ , $I_L = 150\text{ mA}$ , $-40^{\circ}\text{C} \leq T_A \leq +125^{\circ}\text{C}$ , V Input = "1", unless otherwise noted.)(1)

Characteristic	Symbol	Min	Typ	Max	Unit
Operating Voltage	$V_{IGN(min)}$	4.5	-	-	V
Switch Voltage Drop (Saturation) $V_{IGN} = 4.5\text{ V}$ $I_O = 150\text{ mA}$ , $T_A = 25^{\circ}\text{C}$ $I_O = 200\text{ mA}$ , $T_A = -40^{\circ}\text{C}$ $I_O = 125\text{ mA}$ , $T_A = 125^{\circ}\text{C}$ $V_{IGN} = 12\text{ V}$ $I_O = 425\text{ mA}$ , $T_A = 25^{\circ}\text{C}$ $I_O = 550\text{ mA}$ , $T_A = -40^{\circ}\text{C}$ $V_{IGN} = 16\text{ V}$ $I_O = 375\text{ mA}$ , $T_A = 125^{\circ}\text{C}$	$V_{IGN-VO}$	- - - - - -	0.2 0.3 0.3 0.3 0.3 0.4	0.5 0.5 0.5 0.7 0.7 0.7	V
Quiescent Current $V_{IGN} = 12\text{ V}$ $I_O = 150\text{ mA}$ , $T_A = 25^{\circ}\text{C}$ $I_O = 550\text{ mA}$ , $T_A = -40^{\circ}\text{C}$ $I_O = 300\text{ mA}$ , $T_A = 125^{\circ}\text{C}$	$I_{GND}$	- - -	12 25 10	50 100 50	mA
Output Current Limit ( $V_O = 0\text{ V}$ )	$I_{SC}$	-	1.6	2.5	A
Output Leakage Current ( $V_{IGN} = 12\text{ V}$ , Input = "0")	$I_{Leak}$	-	10	150	$\mu\text{A}$
Input Voltage High Logic State Low Logic State	$V_{IH}$ $V_{IL}$	2.0 -	- -	- 0.8	V
Input Current High Logic State ( $V_{IH} = 5.5\text{ V}$ ) Low Logic State ( $V_{IL} = 0.4\text{ V}$ )	$I_{IH}$ $I_{IL}$	- -	120 20	- -	$\mu\text{A}$
Output Turn-On Delay Time Input = "0" $\rightarrow$ "1", $T_A = +25^{\circ}\text{C}$ (Figures 1 and 3)	$t_{DLY(on)}$	-	50	-	$\mu\text{s}$
Output Turn-Off Delay Time Input = "1" $\rightarrow$ "0", $T_A = +25^{\circ}\text{C}$ (Figures 1 and 3)	$t_{DLY(off)}$	-	5.0	-	$\mu\text{s}$
Overvoltage Shutdown Threshold	$V_{in(OV)}$	26	31	36	V
Output Turn-Off Delay Time ( $T_A = +25^{\circ}\text{C}$ ) to Overvoltage Condition, $V_{in}$ stepped from 12 V to 40 V, $V \leq 0.9 V_O$ (Figures 1 and 3)	$t_{DLY}$	-	2.0	-	$\mu\text{s}$
Output Recovery Delay Time ( $T_A = +25^{\circ}\text{C}$ ) $V_{IGN}$ stepped from 40 V to 12 V, $V \geq 0.9 V_O$ (Figures 1 and 3)	$t_{RCVY}$	-	5.0	-	$\mu\text{s}$

NOTES: 1. Typical values represent characteristics of operation at  $T_A = 25^{\circ}\text{C}$ .

# MC3399

Figure 1. Transient Response Test Circuit

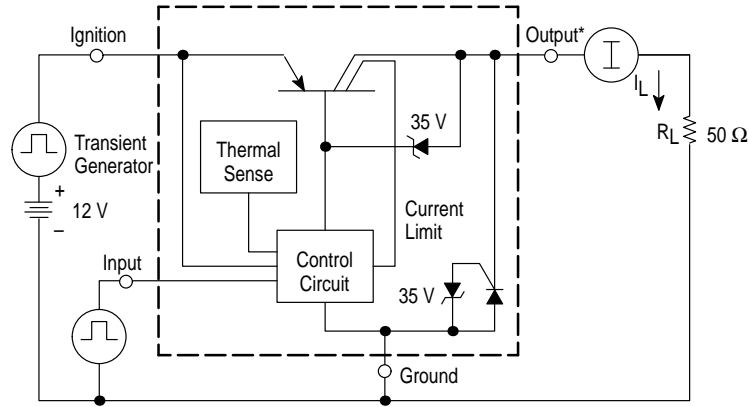

**NOTE:** \* Depending on load current and transient duration, an output capacitor ( $C_O$ ) of sufficient value may be used to hold up output voltage during the transient, and absorb turn-off delay voltage overshoot.

Figure 2. Timing Diagram

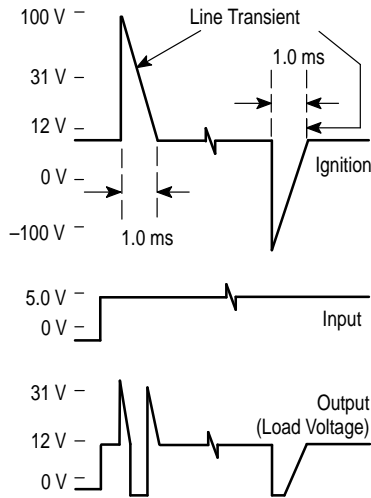

Figure 3. Response Time Diagram

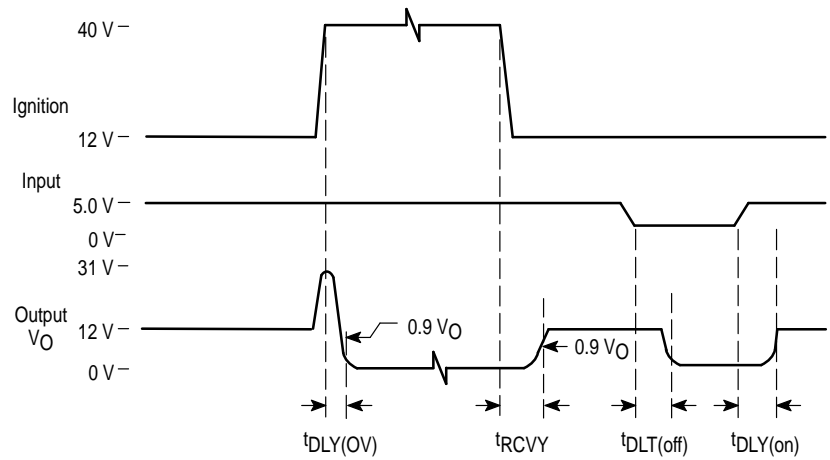

Figure 4. Switch Voltage Drop versus Load Current

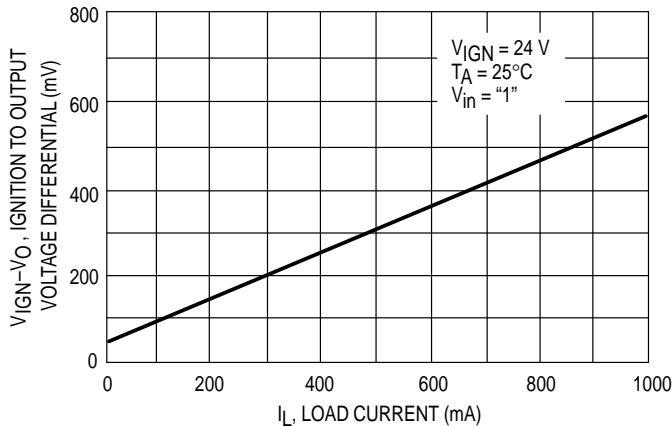
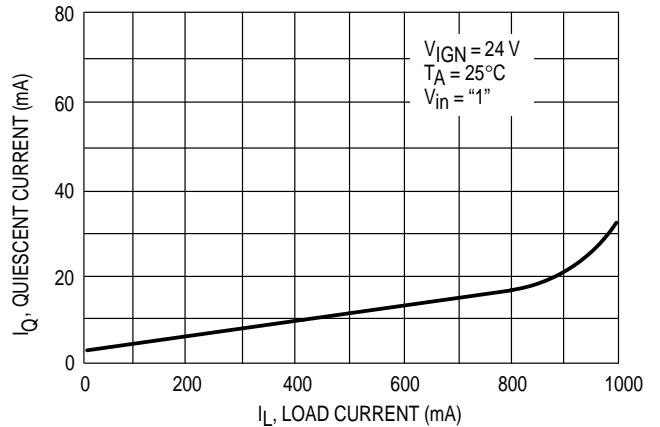

Figure 5. Quiescent Current versus Load Current



# MC3399

## OUTLINE DIMENSIONS

T SUFFIX  
PLASTIC PACKAGE  
CASE 314D-03  
ISSUE D

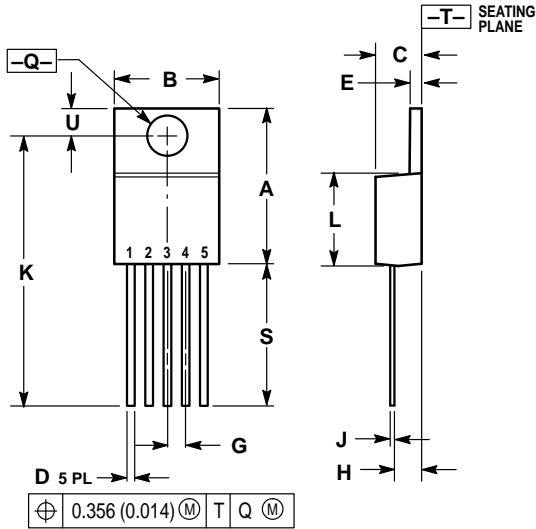

- NOTES:
1. DIMENSIONING AND TOLERANCING PER ANSI Y14.5M, 1982.
  2. CONTROLLING DIMENSION: INCH.
  3. DIMENSION D DOES NOT INCLUDE INTERCONNECT BAR (DAMBAR) PROTRUSION. DIMENSION D INCLUDING PROTRUSION SHALL NOT EXCEED 10.92 (0.043) MAXIMUM.

DIM	INCHES		MILLIMETERS	
	MIN	MAX	MIN	MAX
A	0.572	0.613	14.529	15.570
B	0.390	0.415	9.906	10.541
C	0.170	0.180	4.318	4.572
D	0.025	0.038	0.635	0.965
E	0.048	0.055	1.219	1.397
G	0.067 BSC		1.702 BSC	
H	0.087	0.112	2.210	2.845
J	0.015	0.025	0.381	0.635
K	1.020	1.065	25.908	27.051
L	0.320	0.365	8.128	9.271
Q	0.140	0.153	3.556	3.886
U	0.105	0.117	2.667	2.972
S	0.543	0.582	13.782	14.783

DW SUFFIX  
PLASTIC PACKAGE  
CASE 751G-03  
(SOP(8+8)L)  
ISSUE B

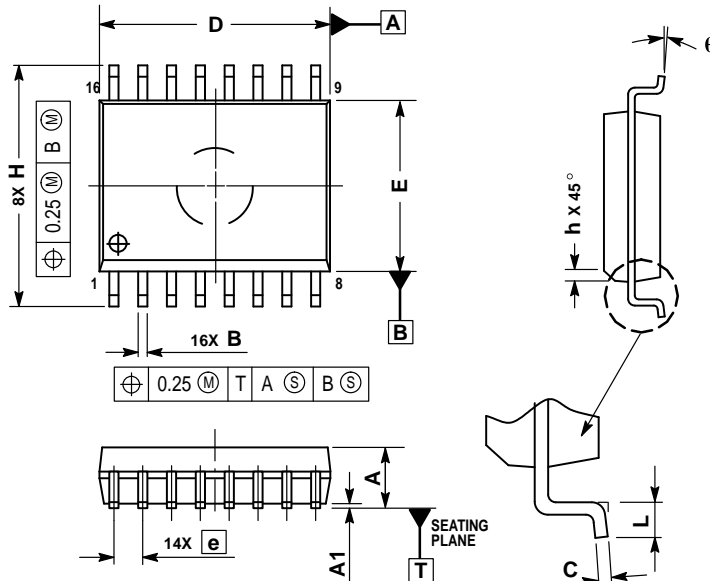

- NOTES:
1. DIMENSIONS ARE IN MILLIMETERS.
  2. INTERPRET DIMENSIONS AND TOLERANCES PER ASME Y14.5M, 1994.
  3. DIMENSIONS D AND E DO NOT INCLUDE MOLD PROTRUSION.
  4. MAXIMUM MOLD PROTRUSION 0.15 PER SIDE.
  5. DIMENSION B DOES NOT INCLUDE DAMBAR PROTRUSION. ALLOWABLE DAMBAR PROTRUSION SHALL BE 0.13 TOTAL IN EXCESS OF THE B DIMENSION AT MAXIMUM MATERIAL CONDITION.

DIM	MILLIMETERS	
	MIN	MAX
A	2.35	2.65
A1	0.10	0.25
B	0.35	0.49
C	0.23	0.32
D	10.15	10.45
E	7.40	7.60
e	1.27 BSC	
H	10.05	10.55
h	0.25	0.75
L	0.50	0.90
$\theta$	0°	7°

## MC3399

Motorola reserves the right to make changes without further notice to any products herein. Motorola makes no warranty, representation or guarantee regarding the suitability of its products for any particular purpose, nor does Motorola assume any liability arising out of the application or use of any product or circuit, and specifically disclaims any and all liability, including without limitation consequential or incidental damages. "Typical" parameters which may be provided in Motorola data sheets and/or specifications can and do vary in different applications and actual performance may vary over time. All operating parameters, including "Typicals" must be validated for each customer application by customer's technical experts. Motorola does not convey any license under its patent rights nor the rights of others. Motorola products are not designed, intended, or authorized for use as components in systems intended for surgical implant into the body, or other applications intended to support or sustain life, or for any other application in which the failure of the Motorola product could create a situation where personal injury or death may occur. Should Buyer purchase or use Motorola products for any such unintended or unauthorized application, Buyer shall indemnify and hold Motorola and its officers, employees, subsidiaries, affiliates, and distributors harmless against all claims, costs, damages, and expenses, and reasonable attorney fees arising out of, directly or indirectly, any claim of personal injury or death associated with such unintended or unauthorized use, even if such claim alleges that Motorola was negligent regarding the design or manufacture of the part. Motorola and  are registered trademarks of Motorola, Inc. Motorola, Inc. is an Equal Opportunity/Affirmative Action Employer.

# MC3399

Mfax is a trademark of Motorola, Inc.

**How to reach us:**

**USA/EUROPE/Locations Not Listed:** Motorola Literature Distribution;  
P.O. Box 5405, Denver, Colorado 80217. 1-303-675-2140 or 1-800-441-2447

**JAPAN:** Nippon Motorola Ltd.: SPD, Strategic Planning Office, 141,  
4-32-1 Nishi-Gotanda, Shagawa-ku, Tokyo, Japan. 03-5487-8488

**Customer Focus Center: 1-800-521-6274**

**Mfax™:** RMFAX0@email.sps.mot.com – TOUCHTONE 1-602-244-6609  
Motorola Fax Back System – US & Canada ONLY 1-800-774-1848  
– <http://sps.motorola.com/mfax/>

**ASIA/PACIFIC:** Motorola Semiconductors H.K. Ltd.; 8B Tai Ping Industrial Park,  
51 Ting Kok Road, Tai Po, N.T., Hong Kong. 852-26629298

**HOME PAGE:** <http://motorola.com/sps/>



**MOTOROLA**