



# LT1039A/LT1039A-16

## Triple RS232 Driver/Receiver with Shutdown

### FEATURES

- **On-Chip ESD Protection:**
  - ±15kV Human Body Model
  - ±15kV IEC-1000-4-2 Air Gap Test\*\*
  - ±8kV IEC-1000-4-2 Contact Test
- 125kBd Operation with 3kΩ/2500pF Load
- 250kBd Operation with 3kΩ/1000pF Load
- Operates from ±5V to ±15V Supplies
- Fully Protected Against Overload
- **Outputs Can Be Driven ±30V Without Damage**
- Three-State Outputs; Outputs Open When Off
- Bipolar Circuit—No Latchup
- ±30V Input Range
- Triple Driver/Receiver
- **No Supply Current in Shutdown**
- 30kΩ Input Impedance
- Meets All RS232 Specifications
- 16-Pin Version—Pin Compatible with MC145406
- Available in SO Package

### DESCRIPTION

The LT<sup>®</sup>1039A is a triple RS232 driver/receiver that includes shutdown. Each receiver will accept up to ±30V input and can drive either TTL or CMOS logic. The RS232 drivers accept TTL logic inputs and output RS232 voltage levels. The outputs are fully protected against overload and can be shorted to ground or up to ±30V without damage to the drivers. Additionally, when the system is shut down or power is off, the outputs are in a high impedance state allowing data line sharing. On-chip ESD protection eliminates the need for external protection devices.

A bias pin allows one receiver to be kept on while the rest of the part is shut down.

The LT1039A is also available in the 16-pin version, without shutdown or bias pin functions.

For applications requiring operation from a single 5V supply, see the LT1180A/LT1181A and LT1130A data sheets.

LT, LTC and LT are registered trademarks of Linear Technology Corporation.

### APPLICATIONS

- RS232 Interface
- Terminals
- Modems

### TYPICAL APPLICATION

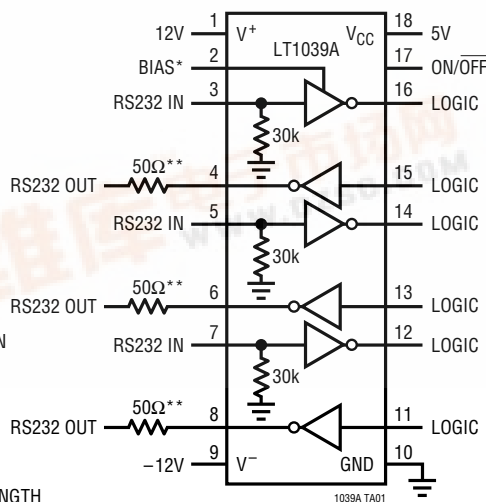

\*BIAS PIN USED TO KEEP THE RECEIVER ON WHILE IN SHUTDOWN

\*\*50Ω RESISTORS MAY BE REQUIRED FOR IEC-1000-4-2 ESD PROTECTION DEPENDING UPON PCB BOARD AND CONNECTOR LEAD LENGTH

Driver Output Swing

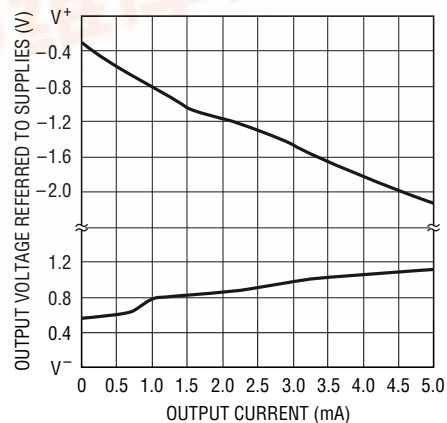

# LT1039A/LT1039A-16

## ABSOLUTE MAXIMUM RATINGS

Supply Voltage		Short-Circuit Duration .....	Indefinite
Driver ( $V^+$ , $V^-$ ) .....	$\pm 16V$	Operating Temperature Range	
Receiver ( $V_{CC}$ ) .....	7V	LT1039AC .....	0°C to 70°C
Logic Inputs .....	$V^-$ to 25V	LT1039AI .....	-40°C to 85°C
Receiver Inputs .....	$\pm 30V$	LT1039AM .....	-55°C to 125°C
ON/OFF Input .....	GND to 12V	Storage Temperature Range .....	-65°C to 150°C
Driver Outputs .....	$V^- + 30V$ to $V^+ - 30V$	Lead Temperature (Soldering, 10 sec) .....	300°C

## PACKAGE/ORDER INFORMATION

<p style="text-align: center;">TOP VIEW</p> <p>J PACKAGE 16-LEAD CERDIP</p> <p>N PACKAGE 16-LEAD PDIP</p> <p>SW PACKAGE 16-LEAD PLASTIC SO WIDE</p> <p><math>T_{JMAX} = 150^{\circ}C</math>, <math>\theta_{JA} = 105^{\circ}C/W</math>, <math>\theta_{JC} = 30^{\circ}C/W</math> (J)  <math>T_{JMAX} = 125^{\circ}C</math>, <math>\theta_{JA} = 90^{\circ}C/W</math>, <math>\theta_{JC} = 50^{\circ}C/W</math> (N)  <math>T_{JMAX} = 125^{\circ}C</math>, <math>\theta_{JA} = 95^{\circ}C/W</math>, <math>\theta_{JC} = 27^{\circ}C/W</math> (SW)</p>	<p style="text-align: center;">ORDER PART NUMBER</p> <p>LT1039ACN16          LT1039ACSW16          LT1039AIN16          LT1039AISW16          LT1039AMJ16</p> <p style="text-align: center;">Consult Factory for Availability</p>	<p style="text-align: center;">TOP VIEW</p> <p>J PACKAGE 18-LEAD CERDIP</p> <p>N PACKAGE 18-LEAD PDIP</p> <p>SW PACKAGE 18-LEAD PLASTIC SO WIDE</p> <p><math>T_{JMAX} = 150^{\circ}C</math>, <math>\theta_{JA} = 88^{\circ}C/W</math>, <math>\theta_{JC} = 22^{\circ}C/W</math> (J)  <math>T_{JMAX} = 125^{\circ}C</math>, <math>\theta_{JA} = 79^{\circ}C/W</math>, <math>\theta_{JC} = 36^{\circ}C/W</math> (N)  <math>T_{JMAX} = 125^{\circ}C</math>, <math>\theta_{JA} = 90^{\circ}C/W</math>, <math>\theta_{JC} = 26^{\circ}C/W</math> (SW)</p>	<p style="text-align: center;">ORDER PART NUMBER</p> <p>LT1039ACN          LT1039ACSW          LT1039AIN          LT1039AISW          LT1039AMJ</p>
---	---	--	---

## ELECTRICAL CHARACTERISTICS

PARAMETER	CONDITIONS	MIN	TYP	MAX	UNITS
<b>Driver <math>V^+ = 12V</math>, <math>V^- = -12V</math>, <math>V_{ON/OFF} = 2.5V</math> (Note 1)</b>					
Output Voltage Swing	Load = 3k to Ground Positive Negative	● ●	$V^+ - 2.0$ $V^- + 1.5$	$V^+ - 1.3$ $V^- + 1.0$	V V
Logic Input Voltage Levels	Input Low Level ( $V_{OUT} = \text{High}$ ) Input High Level ( $V_{OUT} = \text{Low}$ )	● ●	2.0	1.4 1.4	0.8 V
Logic Input Current	$V_{IN} \geq 2.0V$ $V_{IN} \leq 0.8V$			1 5	20 20 $\mu A$ $\mu A$
Output Short-Circuit Current	Sourcing Current, $V_{OUT} = 0V$ Sinking Current, $V_{OUT} = 0V$			20 -15	30 -30 mA mA
Output Leakage Current	Shutdown (Notes 2, 3), $V_{OUT} = \pm 18V$ , $V_{IN} = 0V$	●		10	200 $\mu A$
Supply Leakage Current	Shutdown (Note 2)	●		1	100 $\mu A$
Slew Rate	$R_L = 3k$ , $C_L = 51pF$ to 2500pF		4	15	30 V/ $\mu s$
Supply Current	$V_{OUT} = \text{Low}$			1	5 mA

## ELECTRICAL CHARACTERISTICS

PARAMETER	CONDITIONS	MIN	TYP	MAX	UNITS
Prop Delay ( $t_{PLH}$ ) ( $t_{PHL}$ )			0.6 0.8	1.2 1.2	$\mu$ s $\mu$ s
<b>Receiver <math>V_{CC} = 5V</math>, <math>V_{ON/OFF} = 2.5V</math> (Note 1)</b>					
Input Voltage Thresholds	Input Low Level ( $V_{OUT} = \text{High}$ )	●	0.5	1.3	V
	Input High Level ( $V_{OUT} = \text{Low}$ )	●		1.7 2.8	V
Hysteresis		●	0.1	0.4 1.0	V
Input Resistance		●	30		k $\Omega$
Output Voltage	Output Low, $I_{OUT} = -1.6\text{mA}$	●		0.4	V
	Output High, $I_{OUT} = 160\mu\text{A}$	●	3.5	4.8 0.5	V
Output Short-Circuit Current	Sourcing Current, $V_{OUT} = V_{CC}$	●	-10	-30	mA
	Sinking Current, $V_{OUT} = 0V$	●	15	25	mA
Output Leakage Current	Shutdown (Note 1), $0V \leq V_{OUT} \leq V_{CC}$ , $V_{IN} = 0V$	●		1 10	$\mu$ A
Supply Current	(Note 4)	●	2	5	mA
Supply Leakage Current	Shutdown (Note 2)	●	1	100	$\mu$ A
ON/OFF Pin Current	$0V \leq V_{ON/OFF} \leq 5V$	●	-15	80	$\mu$ A
Prop Delay ( $t_{PLH}$ ) ( $t_{PHL}$ )			200 300	600 600	ns ns

The ● denotes specifications which apply over the full operating temperature range.

**Note 1:**  $V_{ON/OFF} = 5V$  for LT1039AM grade devices.

**Note 2:**  $V_{ON/OFF} = 0.4V$  for  $-55^\circ\text{C} \leq T_A \leq 100^\circ\text{C}$  and  $V_{ON/OFF} = 0.2V$  for  $100^\circ\text{C} \leq T_A \leq 125^\circ\text{C}$ . Does not apply to LT1039A-16 part.

**Note 3:** For  $T_A \geq 100^\circ\text{C}$  leakage current is  $350\mu\text{A}$  max.

**Note 4:** Bias pin open on 18-pin version.

## TYPICAL PERFORMANCE CHARACTERISTICS

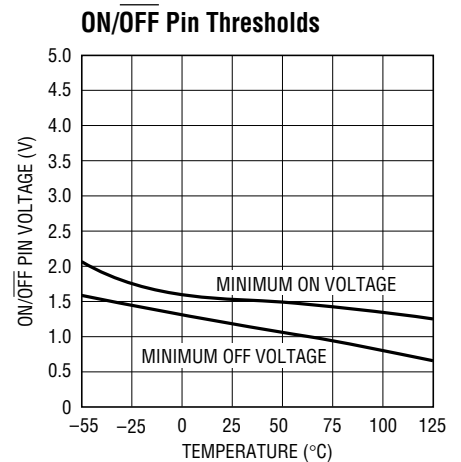
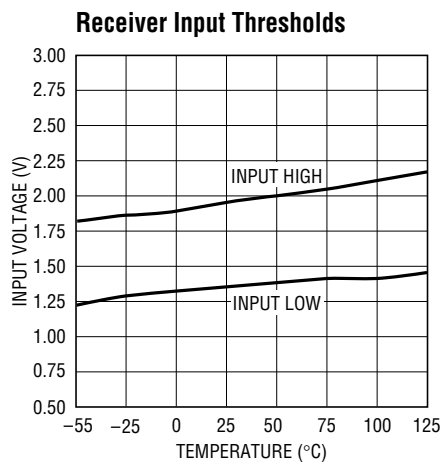
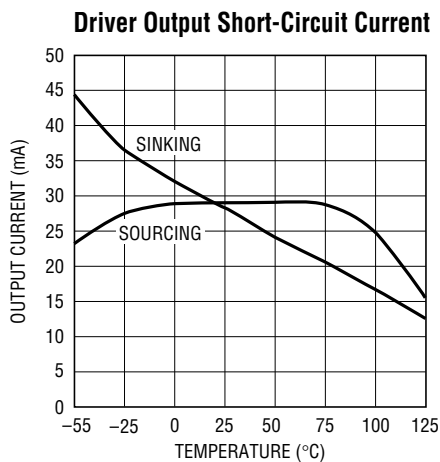

# LT1039A/LT1039A-16

## TYPICAL PERFORMANCE CHARACTERISTICS

**Supply Current in Shutdown**

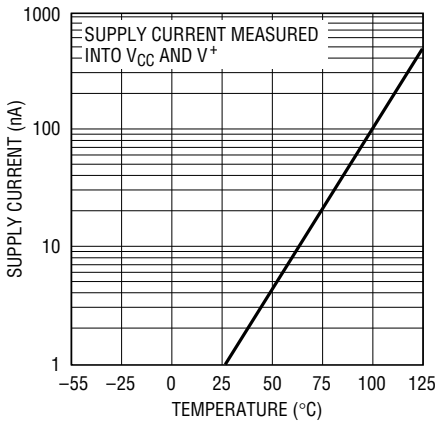

1039A G04

**Driver Output Leakage in Shutdown**

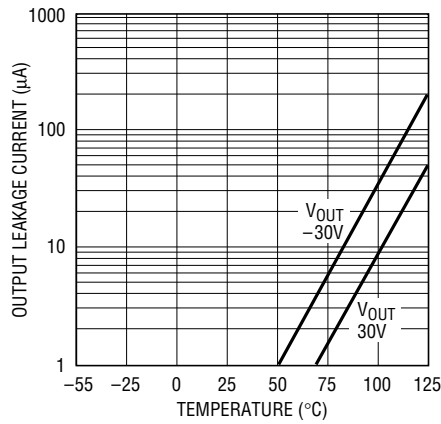

1039A G05

**Receiver Output Short-Circuit Current**

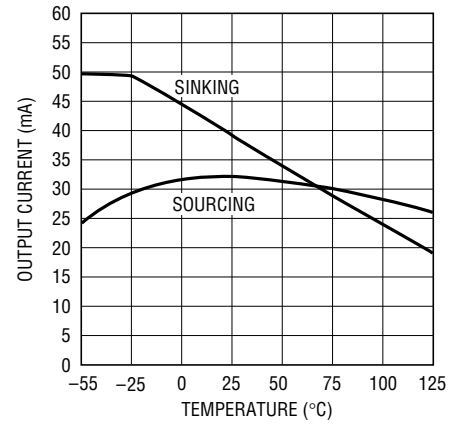

1039A G06

**ON/OFF Pin Current vs Voltage**

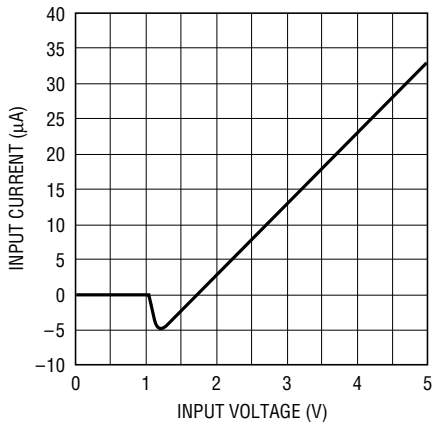

1039A G07

**Driver Output Swing vs Current**

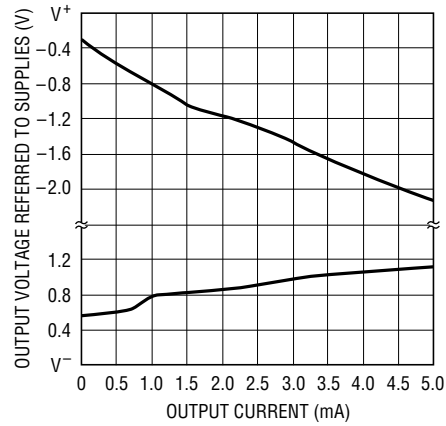

1039A T402

**Output Waveforms**

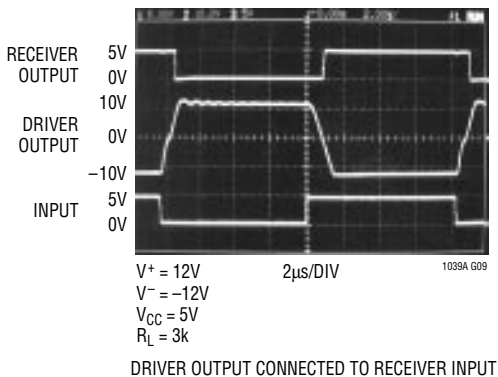

**Shutdown to Driver Output**

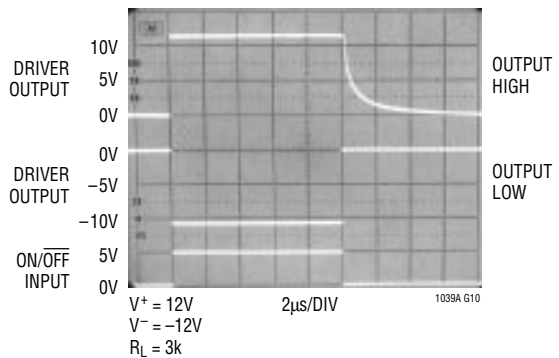

## TYPICAL PERFORMANCE CHARACTERISTICS

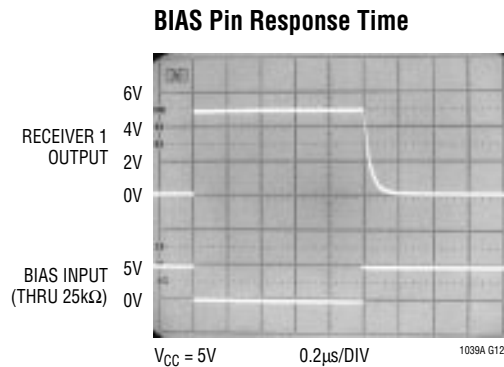
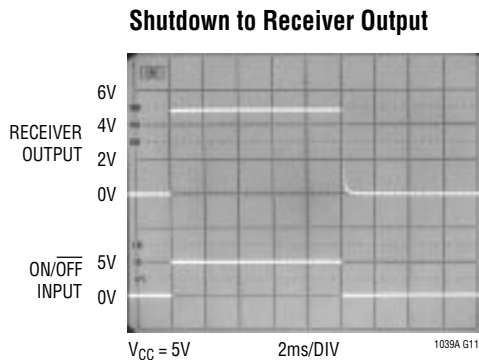

## PIN FUNCTIONS (Pin numbers listed are for 18-pin device)

**V<sup>+</sup>, V<sup>-</sup> (Pins 1, 9):** Driver Supply Pins. Supply current drops to zero in shutdown mode. Driver outputs are in a high impedance state when V<sup>+</sup> and V<sup>-</sup> = 0V.

**BIAS (Pin 2):** Keeps receiver 1 on while the LT1309A is in the shutdown mode. Leave BIAS pin open when not in use. See Applications Information for proper use.

**REC IN (Pins 3, 5, 7):** Receiver Input Pins. Accepts RS232 voltage levels ( $\pm 30V$ ) and has 0.4V of hysteresis to provide noise immunity. Input impedance is nominally 30k $\Omega$ . Receiver input pins are internally protected from ESD transients. In order to insure proper functioning of the ESD protection devices, the  $V_{CC}$  and V<sup>-</sup> supply pins must be bypassed with low ESR capacitors located close to the pins. A 0.1 $\mu$ F ceramic capacitor works well.

**TR OUT (Pins 4, 6, 8):** Driver Outputs with RS232 Voltage Levels. Outputs are in a high impedance state when in the shutdown mode or when power is off (V<sup>+</sup> and V<sup>-</sup> = 0V) to allow data line sharing. Outputs are fully short-circuit protected from V<sup>-</sup> + 30V to V<sup>+</sup> - 30V with power on, off or in the shutdown mode. Typical output breakdowns are greater than  $\pm 45V$  and higher applied voltages will not damage the device if moderately current limited. Driver

output pins are internally protected from ESD transients. In order to insure proper functioning of the ESD protection devices, the V<sup>+</sup> and V<sup>-</sup> supply pins must be bypassed with low ESR capacitors located close to the pins. 0.1 $\mu$ F ceramic capacitors work well.

**GND (Pin 10):** Ground Pin.

**TR IN (Pins 11, 13, 15):** RS232 Driver Input Pins. Inputs are TTL/CMOS compatible. Inputs should not be allowed to float. Tie unused inputs to  $V_{CC}$ .

**REC OUT (Pins 12, 14, 16):** Receiver Outputs with TTL/CMOS Voltage Levels. Outputs are in a high impedance state when in the shutdown mode to allow data line sharing. Outputs are fully short-circuit protected to ground or  $V_{CC}$  with power on, off or in the shutdown mode.

**ON/OFF (Pin 17):** Controls the operation mode of the LT1039A and is TTL/CMOS compatible. A logic low puts the device in the shutdown mode which reduces input supply current to zero and places both driver and receiver outputs in a high impedance state.

**V<sub>CC</sub> (Pin 18):** 5V Power for Receivers.

# LT1039A/LT1039A-16

## APPLICATIONS INFORMATION

The driver output stage of the LT1039A offers significantly improved protection over older bipolar and CMOS designs. In addition to current limiting, the driver output can be externally forced to  $\pm 30V$  with no damage or excessive current flow.

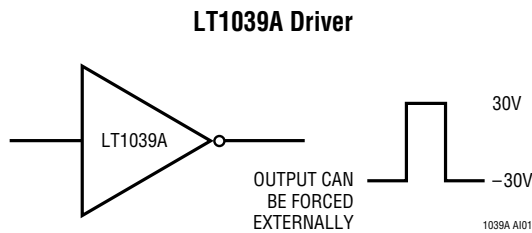

The driver outputs utilize high impedance overvoltage protection, eliminating the flow of fault currents into supplies, as will happen with conventional diode clamp configurations.

### Older RS232 Drivers and Other CMOS Drivers

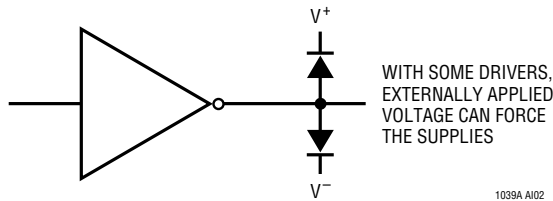

Placing the LT1039A in the shutdown mode (Pin 17 low) puts both the driver and receiver outputs in a high impedance state. This allows data line sharing and transceiver applications.

### Sharing a Transmitter Line

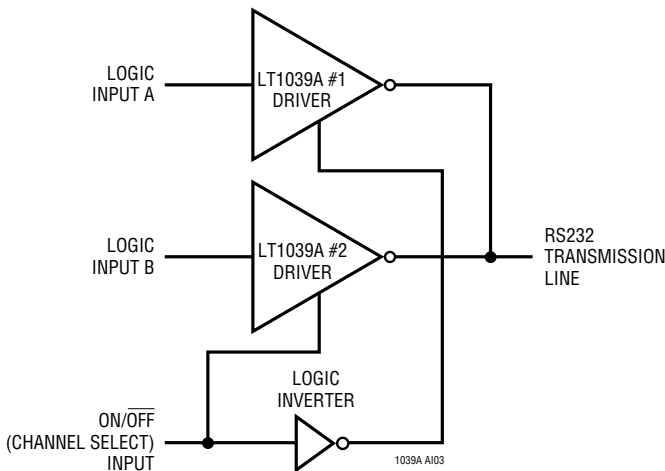

### Sharing a Receiver Line

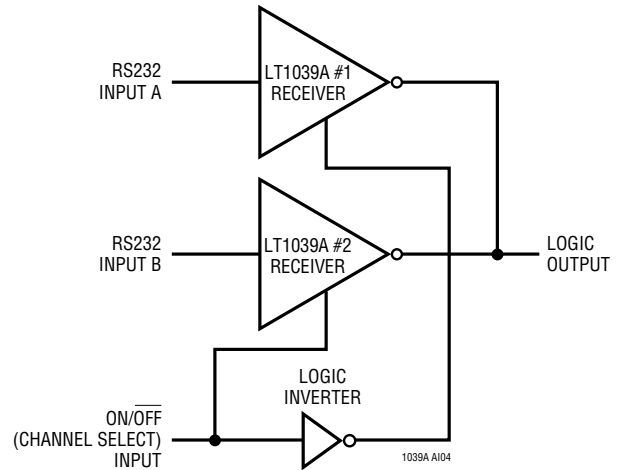

### Transceiver

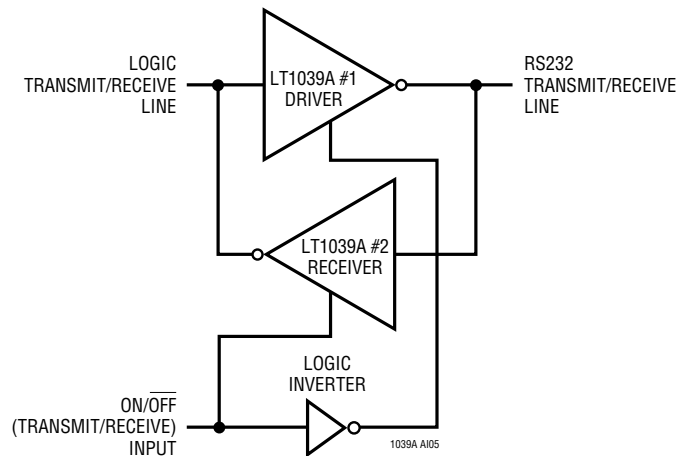

The shutdown mode also drops all supply currents ( $V_{CC}$ ,  $V^+$ ,  $V^-$ ) to zero for power conscious systems.

## APPLICATIONS INFORMATION

When driving CMOS logic from a receiver that will be used in the shutdown mode and there is no other active receiver on the line, a 51k resistor can be placed from the logic input to  $V_{CC}$  to force a definite logic level when the receiver output is in a high impedance state.

### Driving CMOS Logic from a Receiver

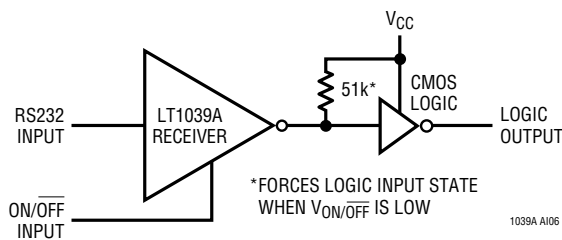

To protect against receiver input overloads in excess of  $\pm 30V$ , a voltage clamp can be placed on the data line and still maintain RS232 compatibility.

### Input Overvoltage Protection

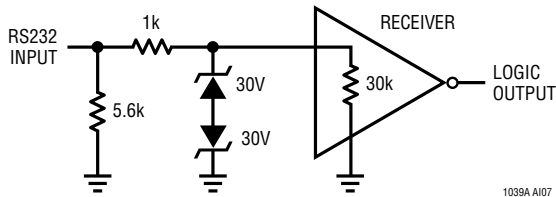

The receiver input impedance of the LT1039A is nominally 30k $\Omega$ . For applications requiring a 5k $\Omega$  input impedance, a 5.6k resistor can be connected from the receiver input to ground.

### 5k $\Omega$ Impedance Matching

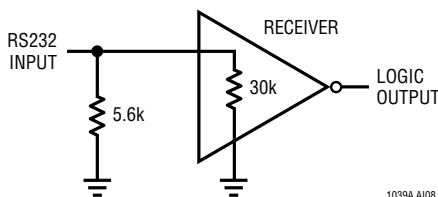

Driver inputs should not be allowed to float. Any unused inputs should be tied to  $V_{CC}$ .

The BIAS pin is used to “keep alive” one receiver while in the shutdown mode (all other circuitry being inactive). This allows a system to be in shutdown and still have one active receiver for transferring data.

### Keeping Alive One Receiver While in Shutdown

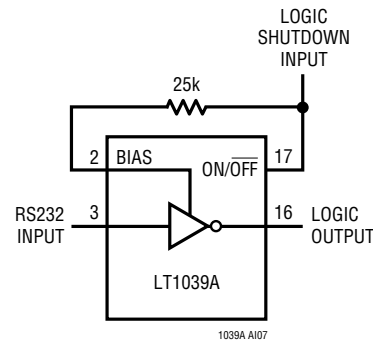

It can also be used to make an RS232 compatible shutdown control line. Driving the BIAS pin low through a resistance of 24k to 30k keeps the receiver active. Do not drive the BIAS pin directly from a logic output without the series resistor. An unused BIAS pin should be left open.

### RS232 Compatible Shutdown Control Line

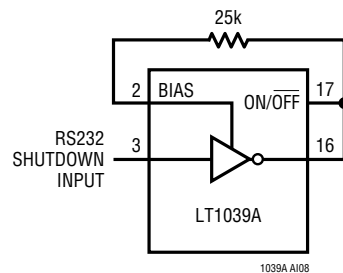

# LT1039A/LT1039A-16

## PACKAGE DESCRIPTION Dimensions in inches (millimeters) unless otherwise noted.

### J Package 16-Lead CERDIP (Narrow 0.300, Hermetic) (LTC DWG # 05-08-1110)

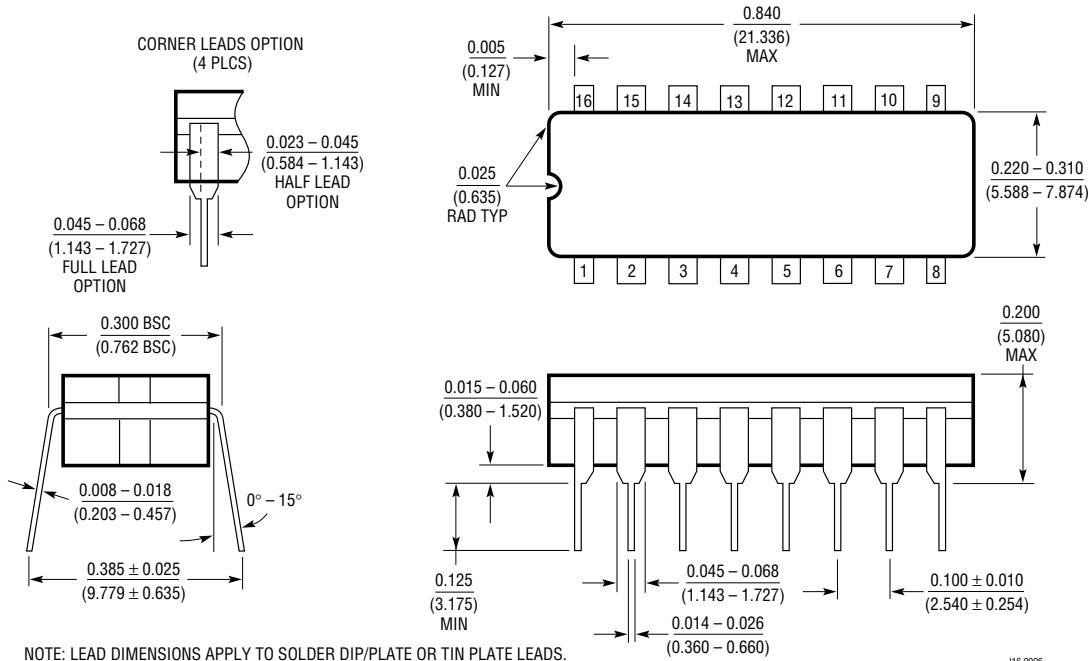

### J Package 18-Lead CERDIP (Narrow 0.300, Hermetic) (LTC DWG # 05-08-1110)

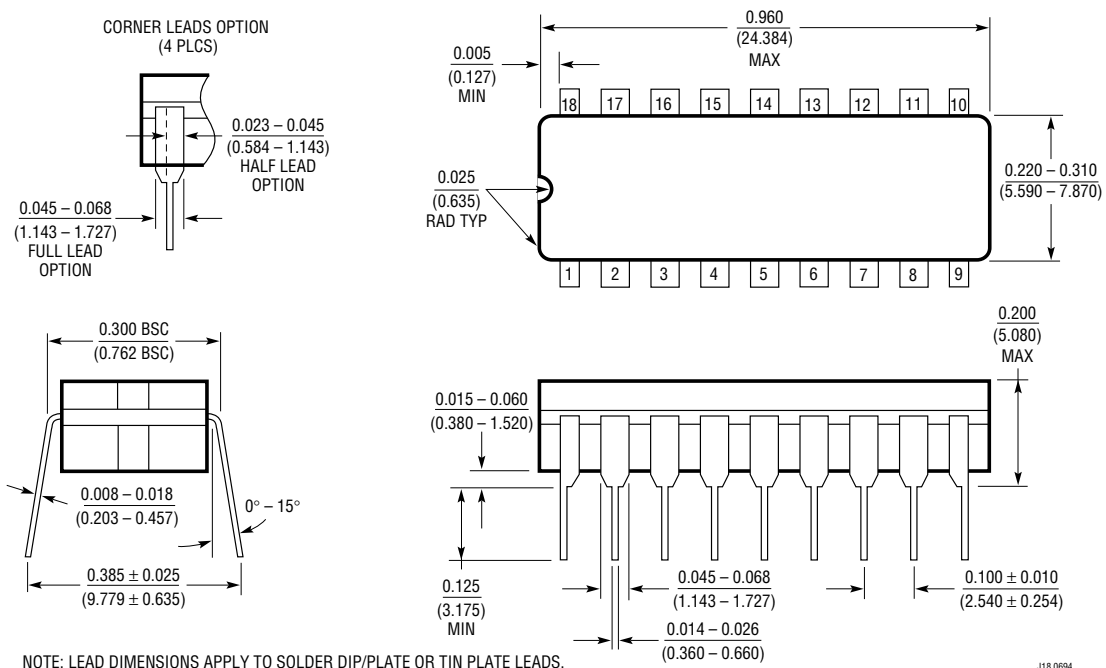

**PACKAGE DESCRIPTION** Dimensions in inches (millimeters) unless otherwise noted.

**N Package**  
**16-Lead PDIP (Narrow 0.300)**  
 (LTC DWG # 05-08-1510)

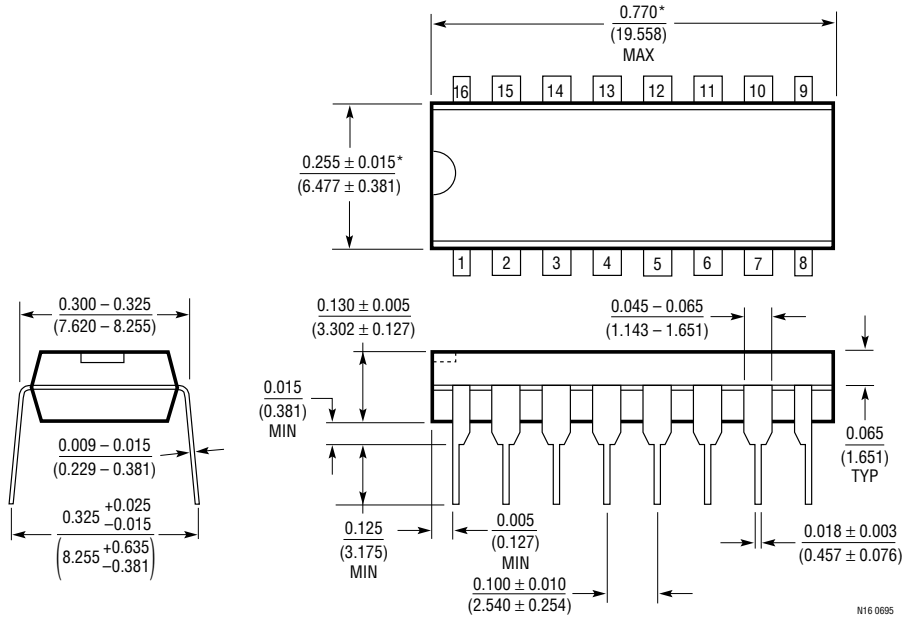

\*THESE DIMENSIONS DO NOT INCLUDE MOLD FLASH OR PROTRUSIONS.  
 MOLD FLASH OR PROTRUSIONS SHALL NOT EXCEED 0.010 INCH (0.254mm)

**N Package**  
**18-Lead PDIP (Narrow 0.300)**  
 (LTC DWG # 05-08-1510)

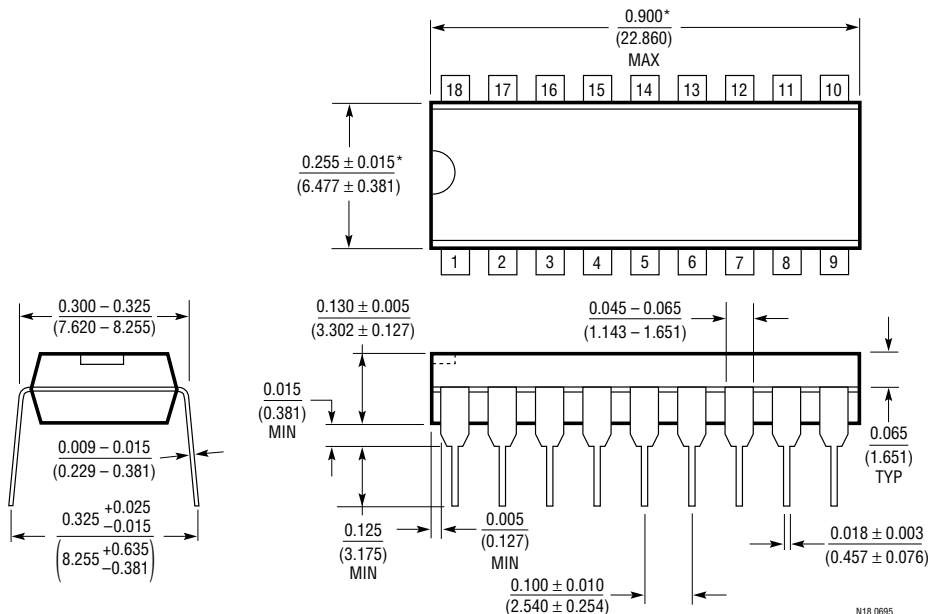

\*THESE DIMENSIONS DO NOT INCLUDE MOLD FLASH OR PROTRUSIONS.  
 MOLD FLASH OR PROTRUSIONS SHALL NOT EXCEED 0.010 INCH (0.254mm)

# LT1039A/LT1039A-16

## PACKAGE DESCRIPTION Dimensions in inches (millimeters) unless otherwise noted.

### SW Package 16-Lead Plastic Small Outline (Wide 0.300) (LTC DWG # 05-08-1620)

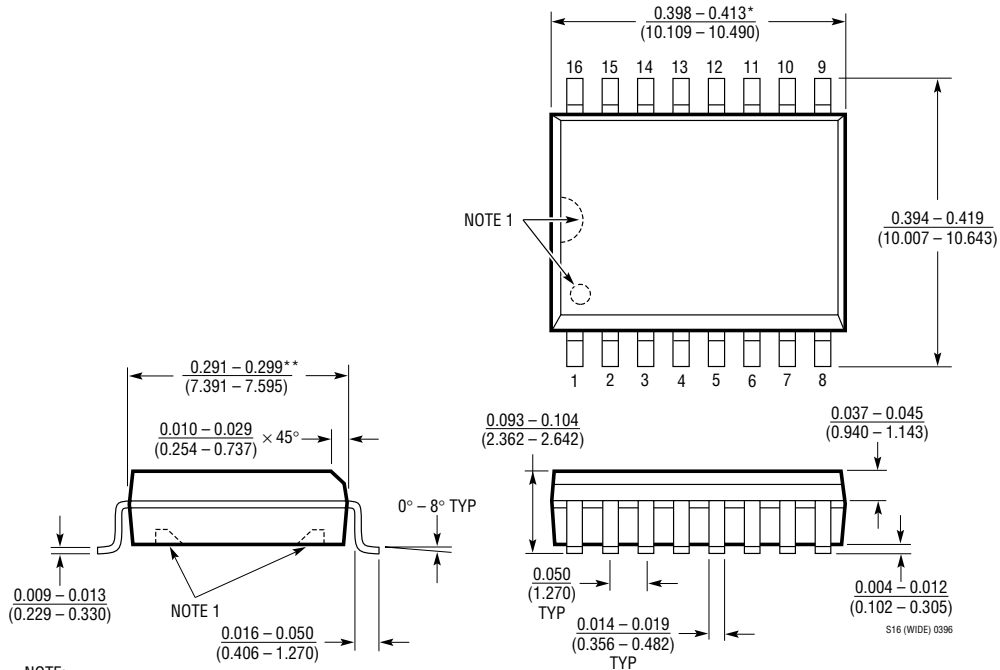

NOTE:  
 1. PIN 1 IDENT, NOTCH ON TOP AND CAVITIES ON THE BOTTOM OF PACKAGES ARE THE MANUFACTURING OPTIONS. THE PART MAY BE SUPPLIED WITH OR WITHOUT ANY OF THE OPTIONS  
 \*DIMENSION DOES NOT INCLUDE MOLD FLASH. MOLD FLASH SHALL NOT EXCEED 0.006" (0.152mm) PER SIDE  
 \*\*DIMENSION DOES NOT INCLUDE INTERLEAD FLASH. INTERLEAD FLASH SHALL NOT EXCEED 0.010" (0.254mm) PER SIDE

**PACKAGE DESCRIPTION** Dimensions in inches (millimeters) unless otherwise noted.

**SW Package**  
**18-Lead Plastic Small Outline (Wide 0.300)**  
 (LTC DWG # 05-08-1620)

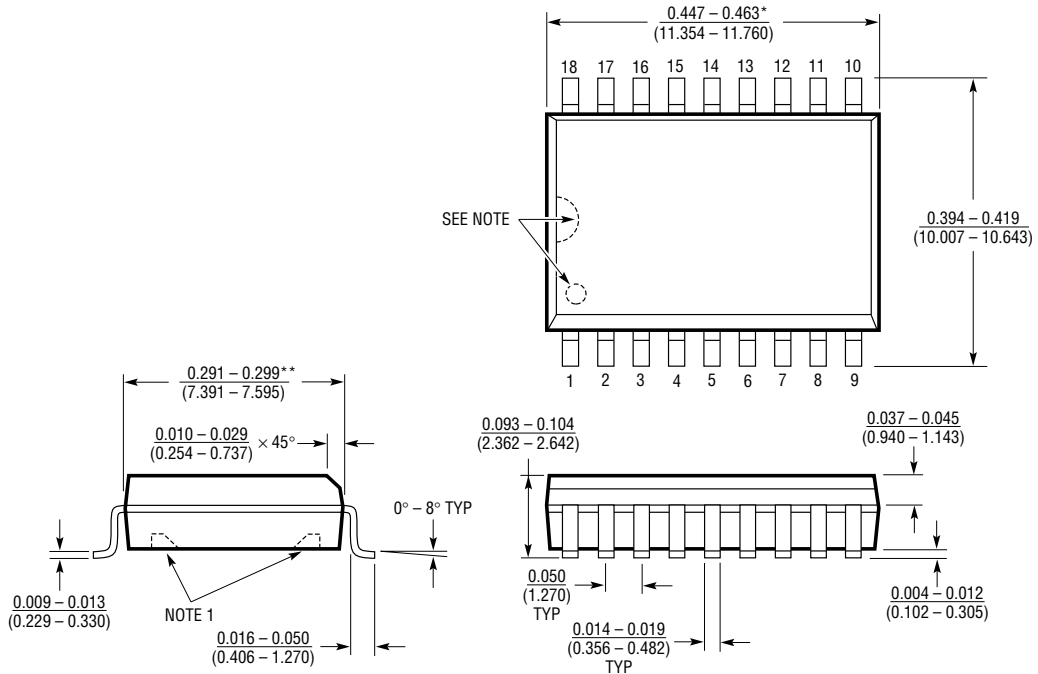

NOTE:  
 1. PIN 1 IDENT, NOTCH ON TOP AND CAVITIES ON THE BOTTOM OF PACKAGES ARE THE MANUFACTURING OPTIONS.  
 THE PART MAY BE SUPPLIED WITH OR WITHOUT ANY OF THE OPTIONS  
 \*DIMENSION DOES NOT INCLUDE MOLD FLASH. MOLD FLASH SHALL NOT EXCEED 0.006" (0.152mm) PER SIDE  
 \*\*DIMENSION DOES NOT INCLUDE INTERLEAD FLASH. INTERLEAD FLASH SHALL NOT EXCEED 0.010" (0.254mm) PER SIDE

S18 (WIDE) 0396

# LT1039A/LT1039A-16

## TYPICAL APPLICATION

LT1180A (Driver/Receiver with Power Supply) Driving an LT1039A

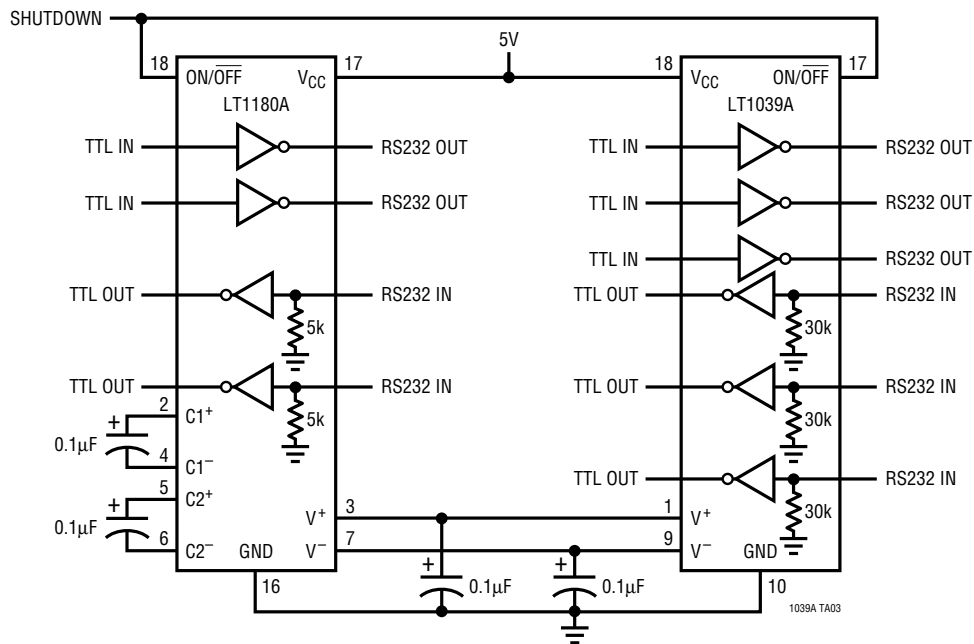

## RELATED PARTS

PART NUMBER	DESCRIPTION	COMMENTS
LTC <sup>®</sup> 485	Low Power RS485 Transceiver	Industry Standard
LT1137A	5V 3 Driver/5 Receiver RS232 Transceiver	±15kV ESD Protection
LT1180A/81A	5V 2 Driver/2 Receiver RS232 Transceiver	Industry Standard, 0.1µF Capacitors
LTC1345	V.35 Transceiver	Single 5V Supply Using 0.1µF Capacitors
LTC1348	3.3V 3 Driver/5 Receiver RS232 Transceiver	Operates from 3.3V to 5V Supplies, 5 Receivers Active in Shutdown