

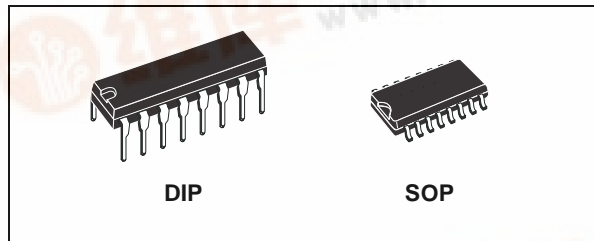

HCF4099B

8 BIT ADDRESSABLE LATCH

- SERIAL DATA INPUT - ACTIVE PARALLEL OUTPUT
- STORAGE REGISTER CAPABILITY - MASTER CLEAR
- CAN FUNCTION AS DEMULTIPLEXER
- QUIESCENT CURRENT SPECIFIED UP TO 20V
- STANDARDIZED SYMMETRICAL OUTPUT CHARACTERISTICS
- INPUT LEAKAGE CURRENT
 $I_l = 100\text{nA (MAX) AT } V_{DD} = 18\text{V } T_A = 25^\circ\text{C}$
- 100% TESTED FOR QUIESCENT CURRENT
- MEETS ALL REQUIREMENTS OF JEDEC JESD13B "STANDARD SPECIFICATIONS FOR DESCRIPTION OF B SERIES CMOS DEVICES"



ORDER CODES

PACKAGE	TUBE	T & R
DIP	HCF4099BEY	
SOP	HCF4099BM1	HCF4099M013TR

DESCRIPTION

HCF4099B is a monolithic integrated circuit fabricated in Metal Oxide Semiconductor technology available in DIP and SOP packages. HCF4099B, an 8-bit addressable latch, is a serial-input, parallel output storage register that can perform a variety of functions. Data is input to a particular bit in the latch when that bit is addressed (by means of input A0, A1, A2) and when WRITE DISABLE is at a low level. When

WRITE DISABLE is high, data entry is inhibited; however, all 8 outputs can be continuously read independent of WRITE DISABLE and address inputs. A master RESET input is available, which resets all bits to a logic "0" level when RESET and WRITE DISABLE are at a high level. When RESET is at a high level, and WRITE DISABLE is at a low level, the latch acts as a 1-of-8 demultiplexer ; the bit that is addressed has an active output which follows the data input, while all unaddressed bits are held to a logic "0" level.

PIN CONNECTION

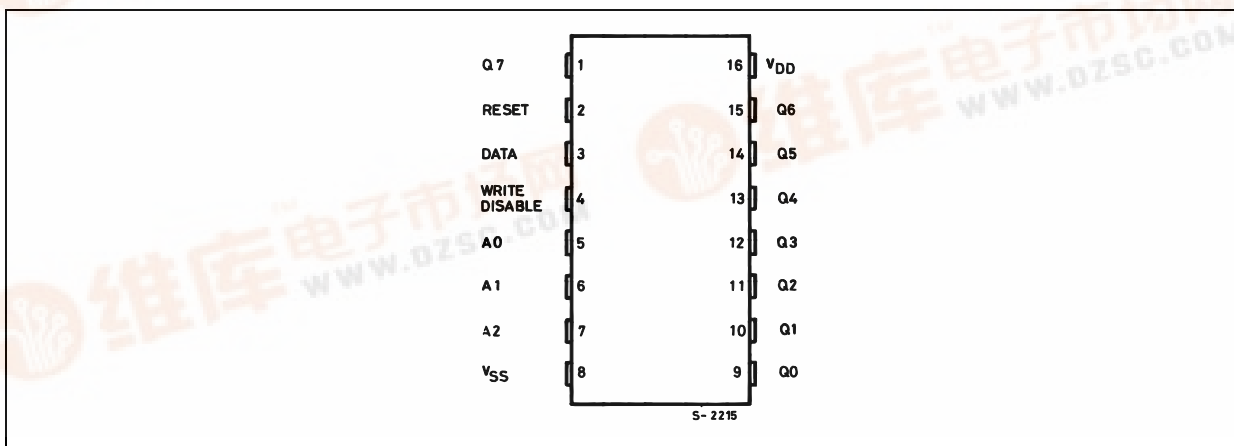

HCF4099B

IINPUT EQUIVALENT CIRCUIT

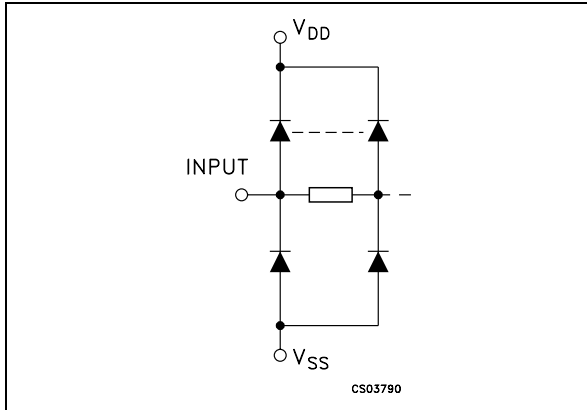

PIN DESCRIPTION

PIN No	SYMBOL	NAME AND FUNCTION
5, 6, 7	A0 to A2	Address Inputs
9, 10, 11, 12, 13, 14, 15, 1	Q0 to Q7	Latch Outputs
3	DATA	Data Inputs
2	RESET	Reset Input
4	WRITE DISABLE	Write Disable Input
8	V _{SS}	Negative Supply Voltage
16	V _{DD}	Positive Supply Voltage

FUNCTIONAL DIAGRAM

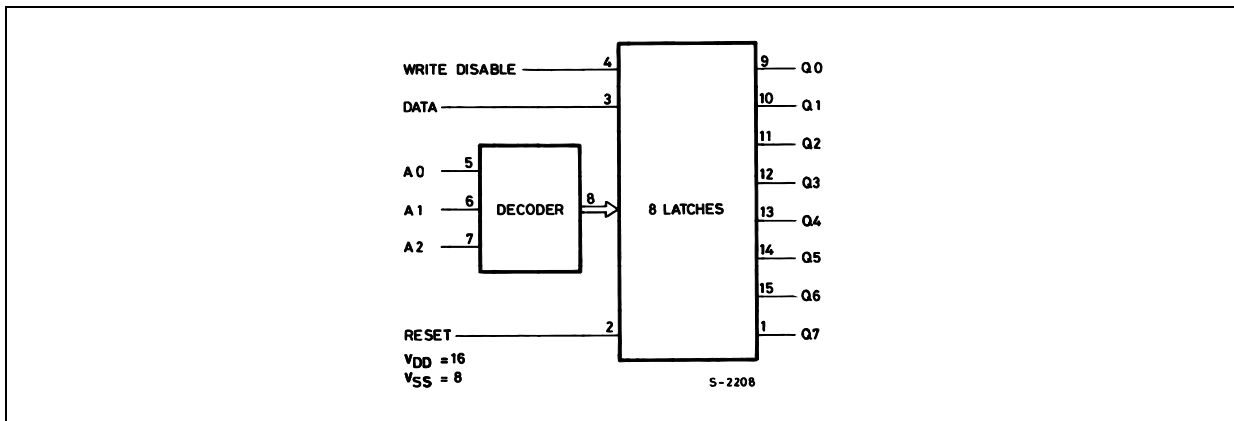

TRUTH TABLE

SELECT INPUTS			LATCH ADDRESSED
C	B	A	
L	L	L	Q0
L	L	H	Q1
L	H	L	Q2
L	H	H	Q3
H	L	L	Q4
H	L	H	Q5
H	H	L	Q6
H	H	H	Q7

INPUTS		OUTPUTS OF ADDRESSED LATCH	EACH OTHER OUTPUT	FUNCTION
WRITE DISABLE	RESET			
L	L	D	Q _{i0}	ADDRESSABLE LATCH
L	H	Q _{i0}	Q _{i0}	MEMORY
H	L	D	L	DEMULTIPLEXER
H	H	L	L	CLEAR ALL BITS TO "0"

D: The level at the data input ; Q_{i0} The level before the indicated steady state input conditions were established, (i=0, 1,...7)

LOGIC DIAGRAM

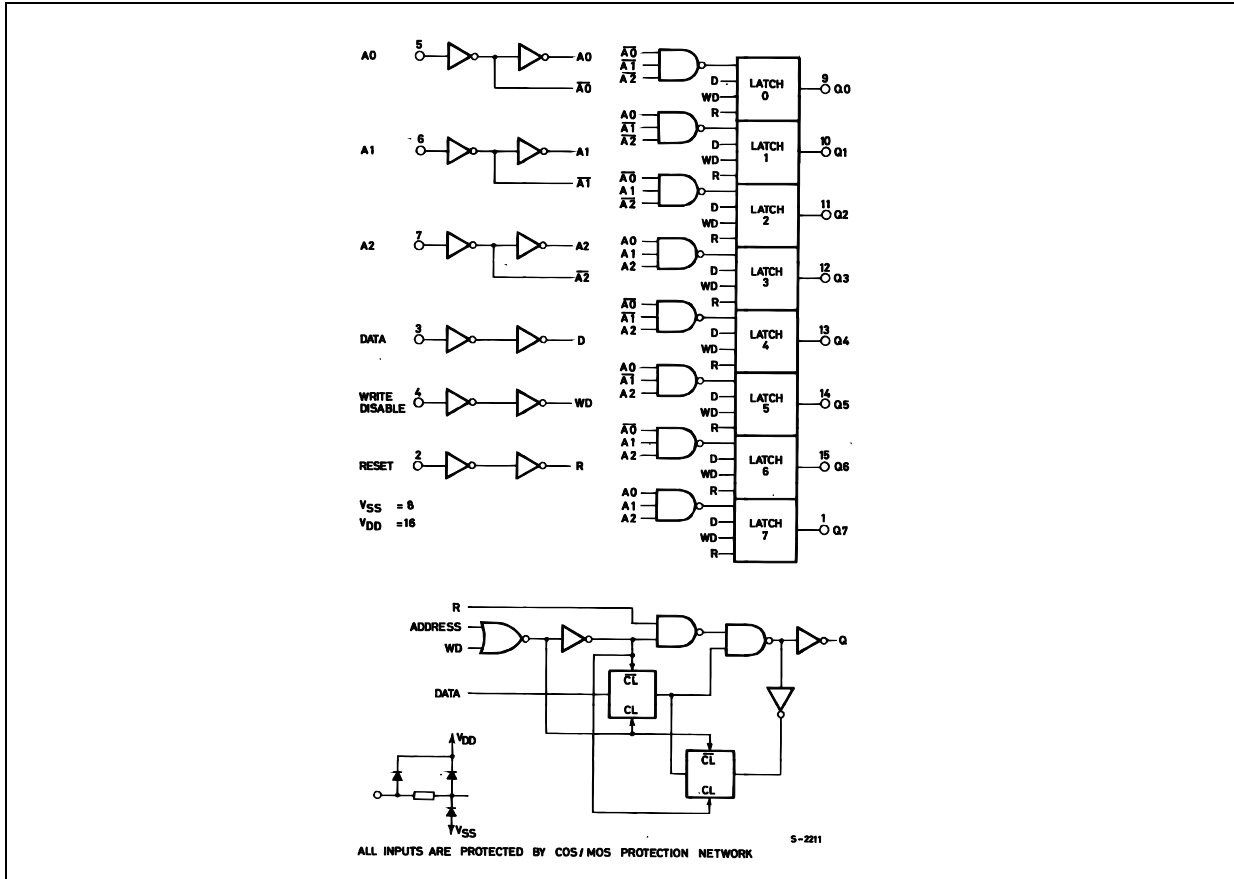

TIMING CHART

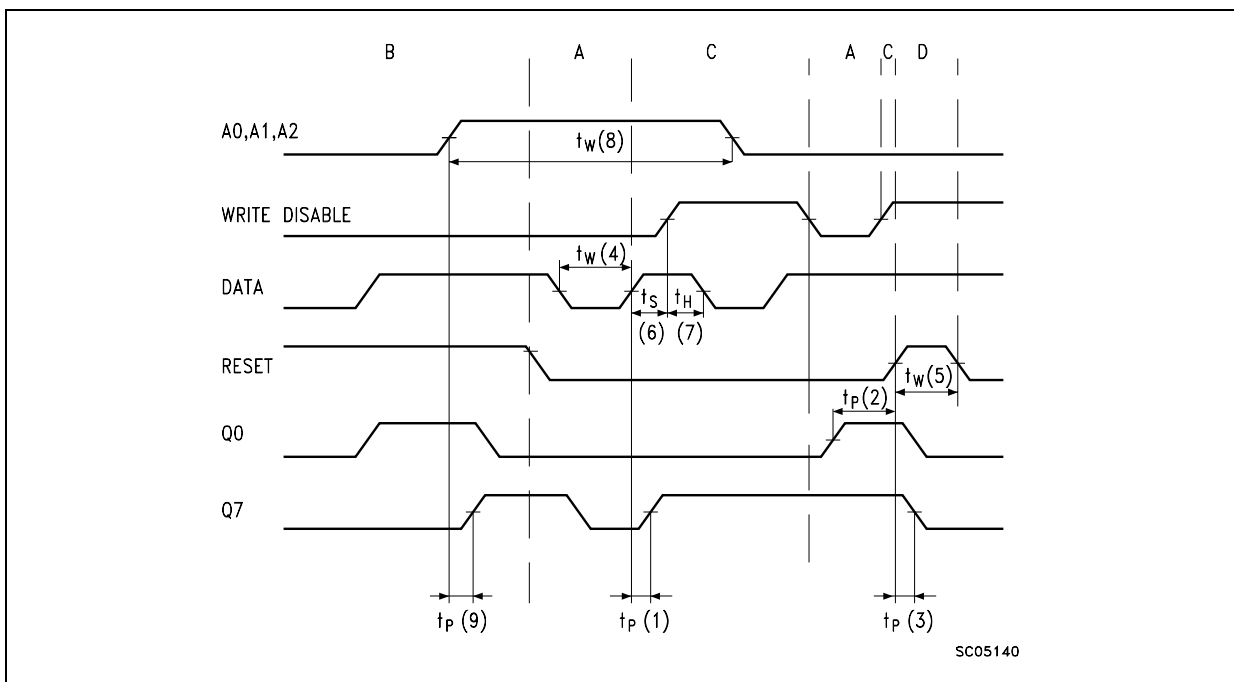

HCF4099B

ABSOLUTE MAXIMUM RATINGS

Symbol	Parameter	Value	Unit
V_{DD}	Supply Voltage	-0.5 to +22	V
V_I	DC Input Voltage	-0.5 to $V_{DD} + 0.5$	V
I_I	DC Input Current	± 10	mA
P_D	Power Dissipation per Package	200	mW
	Power Dissipation per Output Transistor	100	mW
T_{op}	Operating Temperature	-55 to +125	°C
T_{stg}	Storage Temperature	-65 to +150	°C

Absolute Maximum Ratings are those values beyond which damage to the device may occur. Functional operation under these conditions is not implied.

All voltage values are referred to V_{SS} pin voltage.

RECOMMENDED OPERATING CONDITIONS

Symbol	Parameter	Value	Unit
V_{DD}	Supply Voltage	3 to 20	V
V_I	Input Voltage	0 to V_{DD}	V
T_{op}	Operating Temperature	-55 to 125	°C

DC SPECIFICATIONS

Symbol	Parameter	Test Conditions				Value						Unit	
		V _I (V)	V _O (V)	I _O (μ A)	V _{DD} (V)	T _A = 25°C			-40 to 85°C		-55 to 125°C		
						Min.	Typ.	Max.	Min.	Max.	Min.		Max.
I _L	Quiescent Current	0/5			5		0.04	5		150		150	μ A
		0/10			10		0.04	10		300		300	
		0/15			15		0.04	20		600		600	
		0/20			20		0.08	100		3000		3000	
V _{OH}	High Level Output Voltage	0/5		<1	5	4.95			4.95		4.95		V
		0/10		<1	10	9.95			9.95		9.95		
		0/15		<1	15	14.95			14.95		14.95		
V _{OL}	Low Level Output Voltage	5/0		<1	5		0.05			0.05		0.05	V
		10/0		<1	10		0.05			0.05		0.05	
		15/0		<1	15		0.05			0.05		0.05	
V _{IH}	High Level Input Voltage		0.5/4.5	<1	5	3.5			3.5		3.5		V
			1/9	<1	10	7			7		7		
			1.5/18.5	<1	15	11			11		11		
V _{IL}	Low Level Input Voltage		0.5/4.5	<1	5			1.5		1.5		1.5	V
			9/1	<1	10			3		3		3	
			1.5/18.5	<1	15			4		4		4	
I _{OH}	Output Drive Current	0/5	2.5		5	-1.36	-3.2		-1.1		-1.1		mA
		0/5	4.6		5	-0.44	-1		-0.36		-0.36		
		0/10	9.5		10	-1.1	-2.6		-0.9		-0.9		
		0/15	13.5		15	-3.0	-6.8		-2.4		-2.4		
I _{OL}	Output Sink Current	0/5	0.4		5	0.44	1		0.36		0.36		mA
		0/10	0.5		10	1.1	2.6		0.9		0.9		
		0/15	1.5		15	3.0	6.8		2.4		2.4		
I _I	Input Leakage Current	0/18	any input		18		$\pm 10^{-5}$	± 0.1		± 1		± 1	μ A
C _I	Input Capacitance		any input				5	7.5					pF

The Noise Margin for both "1" and "0" level is: 1V min. with V_{DD}=5V, 2V min. with V_{DD}=10V, 2.5V min. with V_{DD}=15V

HCF4099B

DYNAMIC ELECTRICAL CHARACTERISTICS ($T_{amb} = 25^{\circ}\text{C}$, $C_L = 50\text{pF}$, $R_L = 200\text{K}\Omega$, $t_r = t_f = 20\text{ ns}$)

Symbol	Parameter	Test Condition		Value (*)			Unit
		V_{DD} (V)	See Timing Chart	Min.	Typ.	Max.	
t_{PLH} t_{PHL}	Propagation Delay Time (Data to Output)	5	(1)		200	400	ns
		10			75	150	
		15			50	100	
t_{PLH} t_{PHL}	Propagation Delay Time (Write Disable to Output)	5	(2)		200	400	ns
		10			80	160	
		15			60	120	
t_{PLH} t_{PHL}	Propagation Delay Time (Address to Output)	5	(9)		225	450	ns
		10			100	200	
		15			75	150	
t_{PHL}	Propagation Delay Time (Reset to Output)	5	(3)		175	350	ns
		10			80	160	
		15			65	130	
t_{THL} t_{TLH}	Transition Time (any output)	5			100	200	ns
		10			50	100	
		15			40	80	
t_W	Pulse Width (Data)	5	(4)	200	100		ns
		10		100	50		
		15		80	40		
t_W	Pulse Width (Address)	5	(8)	400	200		ns
		10		200	100		
		15		125	65		
t_W	Pulse Width (Reset)	5	(5)	150	75		ns
		10		75	40		
		15		50	25		
t_{setup}	Setup Time (Data to Write Disable)	5	(6)	100	50		ns
		10		50	25		
		15		35	20		
t_{hold}	Hold Time (Data to Write Disable)	5	(7)	150	75		ns
		10		75	40		
		15		50	25		

(*) Typical temperature coefficient for all V_{DD} value is 0.3 %/°C.

TEST CIRCUIT

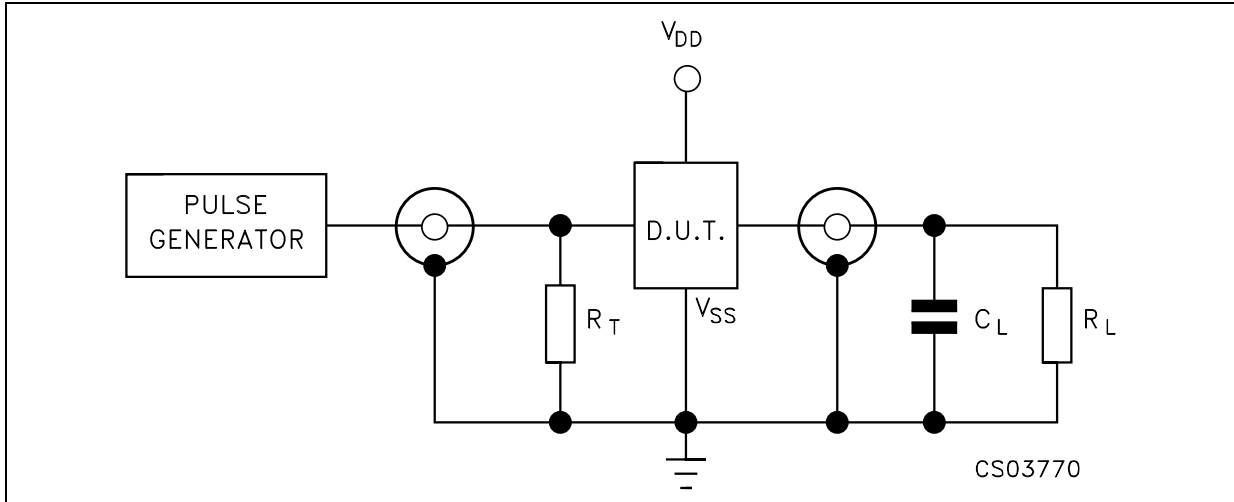

$C_L = 50\text{pF}$ or equivalent (includes jig and probe capacitance)
 $R_L = 200\text{K}\Omega$
 $R_T = Z_{OUT}$ of pulse generator (typically 50Ω)

WAVEFORM 1 : PROPAGATION DELAY TIME ($f=1\text{MHz}$; 50% duty cycle)

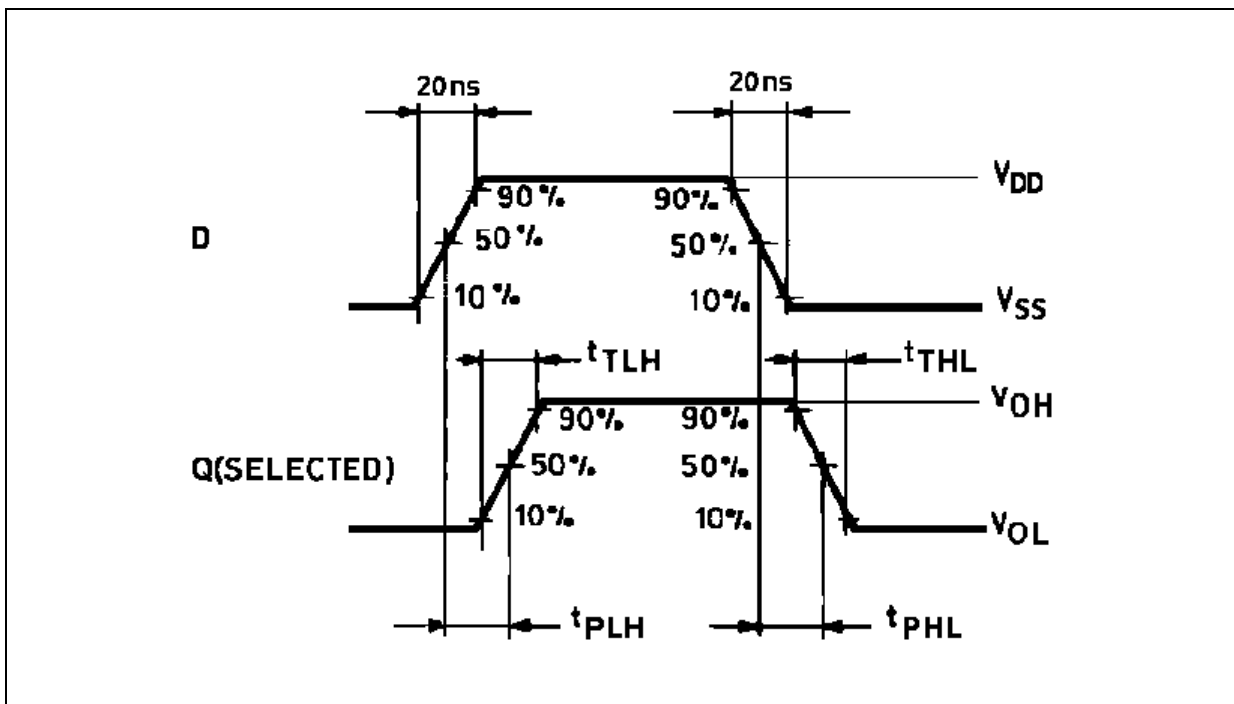

HCF4099B

WAVEFORM 2 : PROPAGATION DELAY TIME (f=1MHz; 50% duty cycle)

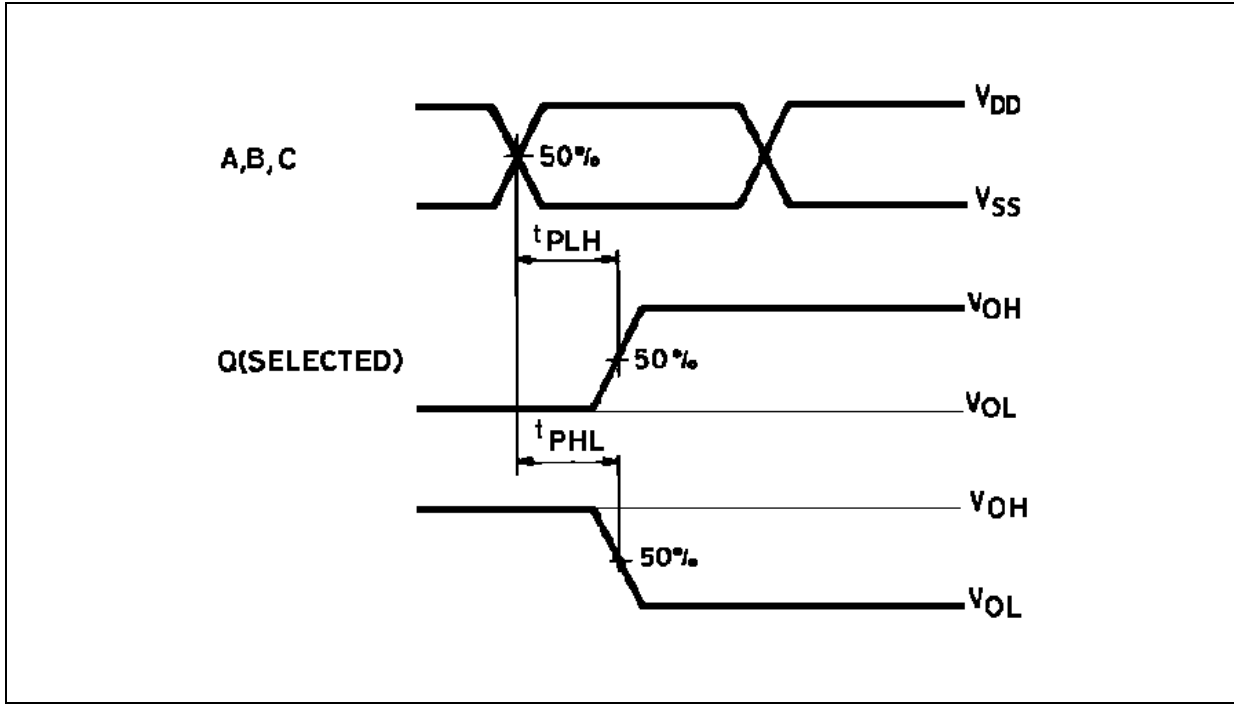

WAVEFORM 3 : MINIMUM PULSE WIDTH, SETUP AND HOLD TIME (f=1MHz; 50% duty cycle)

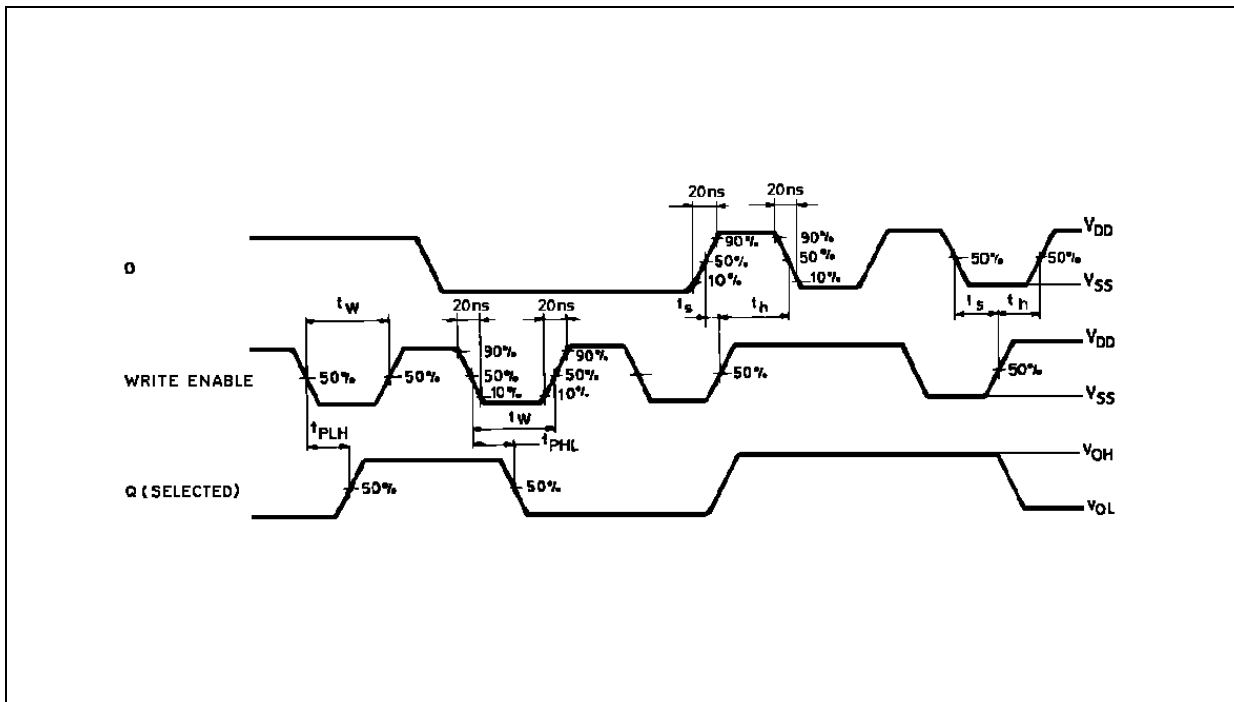

WAVEFORM 4 : MINIMUM PULSE WIDTH (f=1MHz; 50% duty cycle)

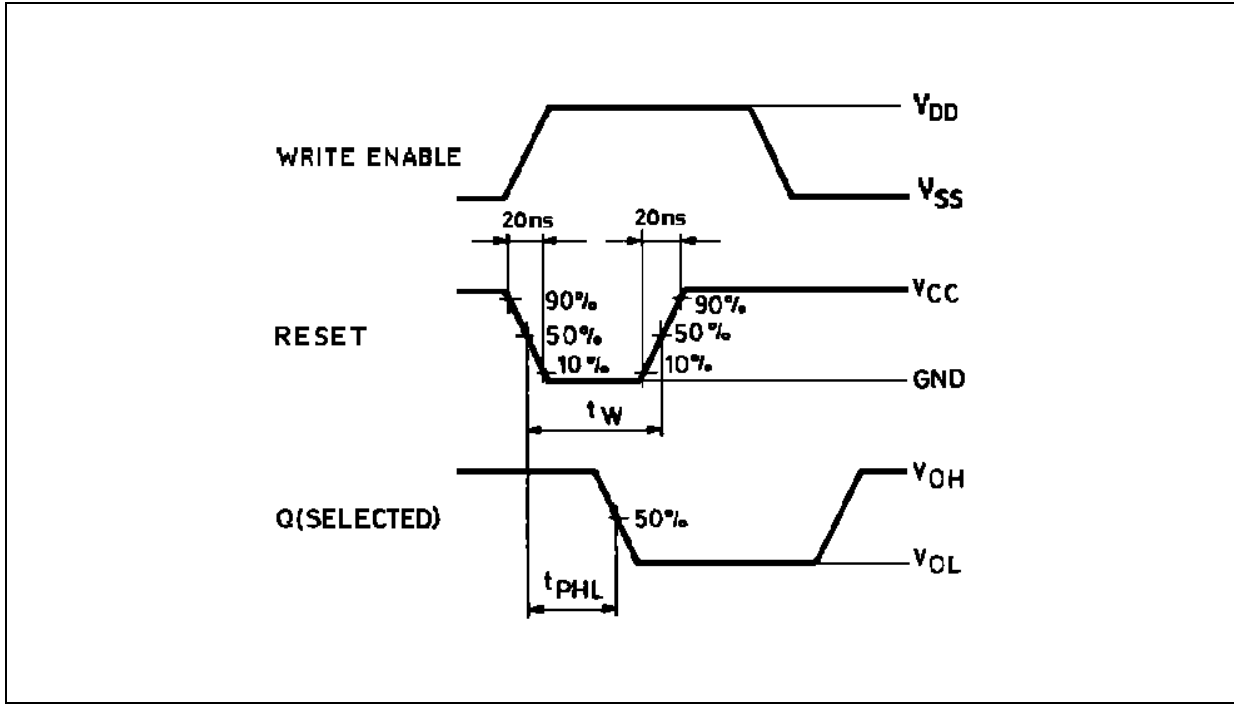

WAVEFORM 5 : SETUP AND HOLD TIME (f=1MHz; 50% duty cycle)

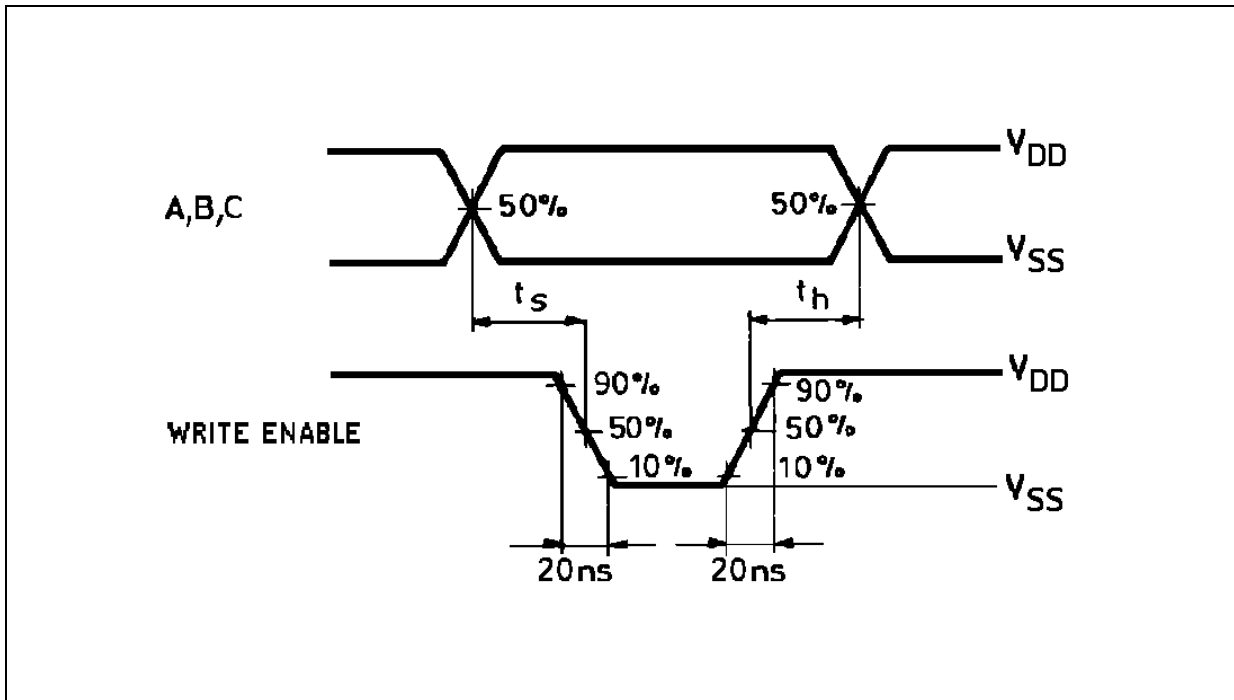

HCF4099B

WAVEFORM 6 : INPUT WAVEFORMS (f=1MHz; 50% duty cycle)

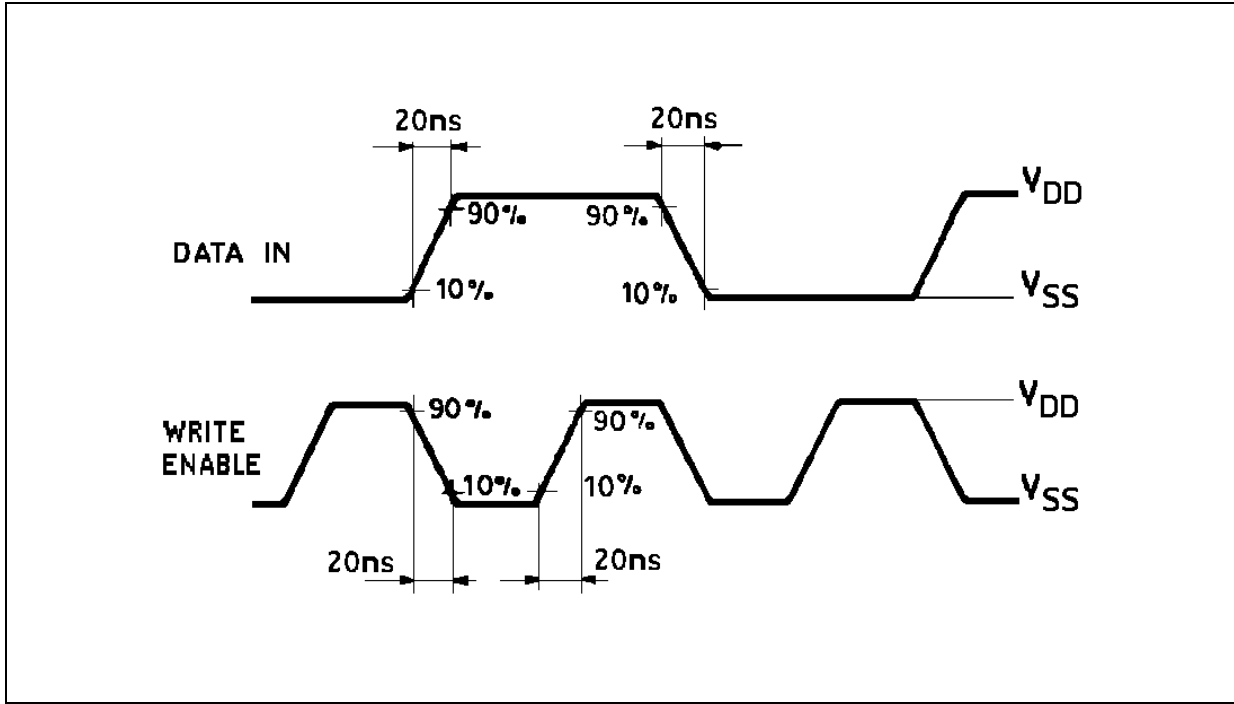

TYPICAL APPLICATIONS

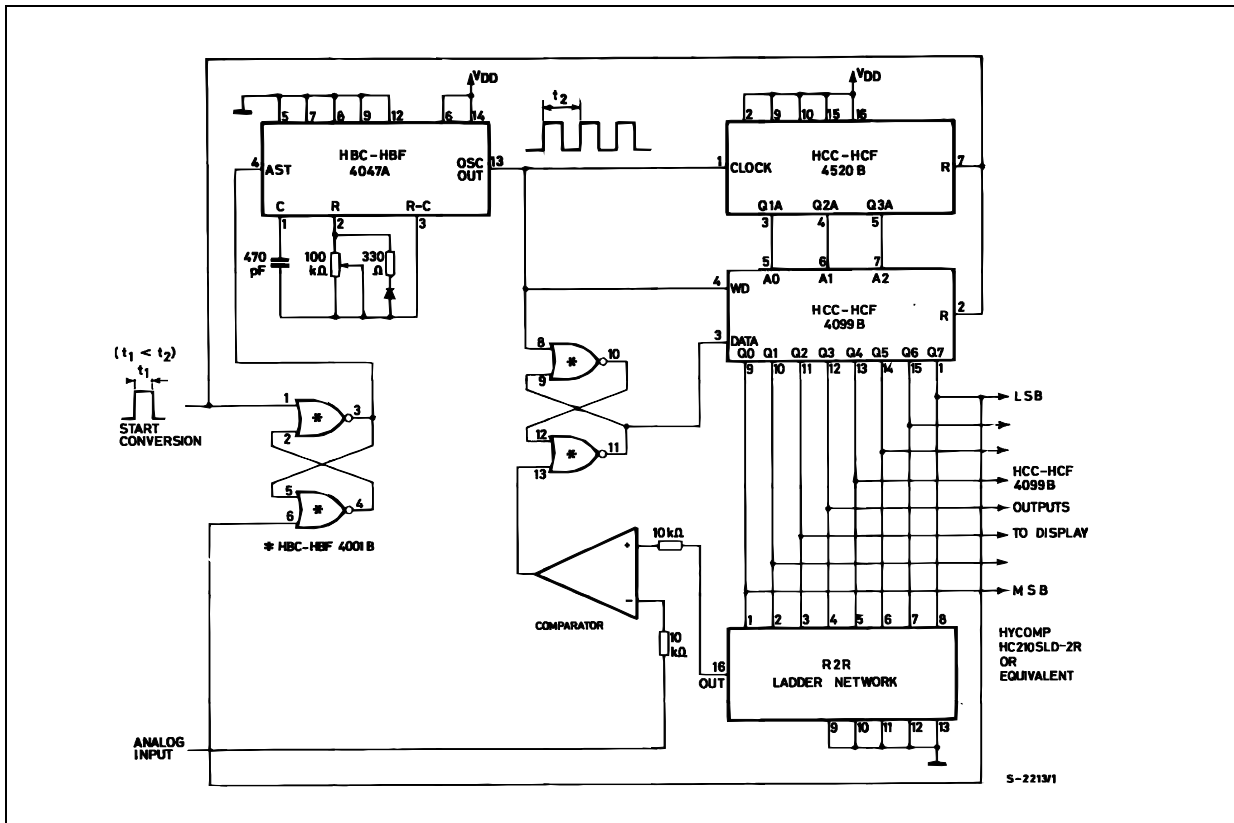

TYPICAL APPLICATIONS

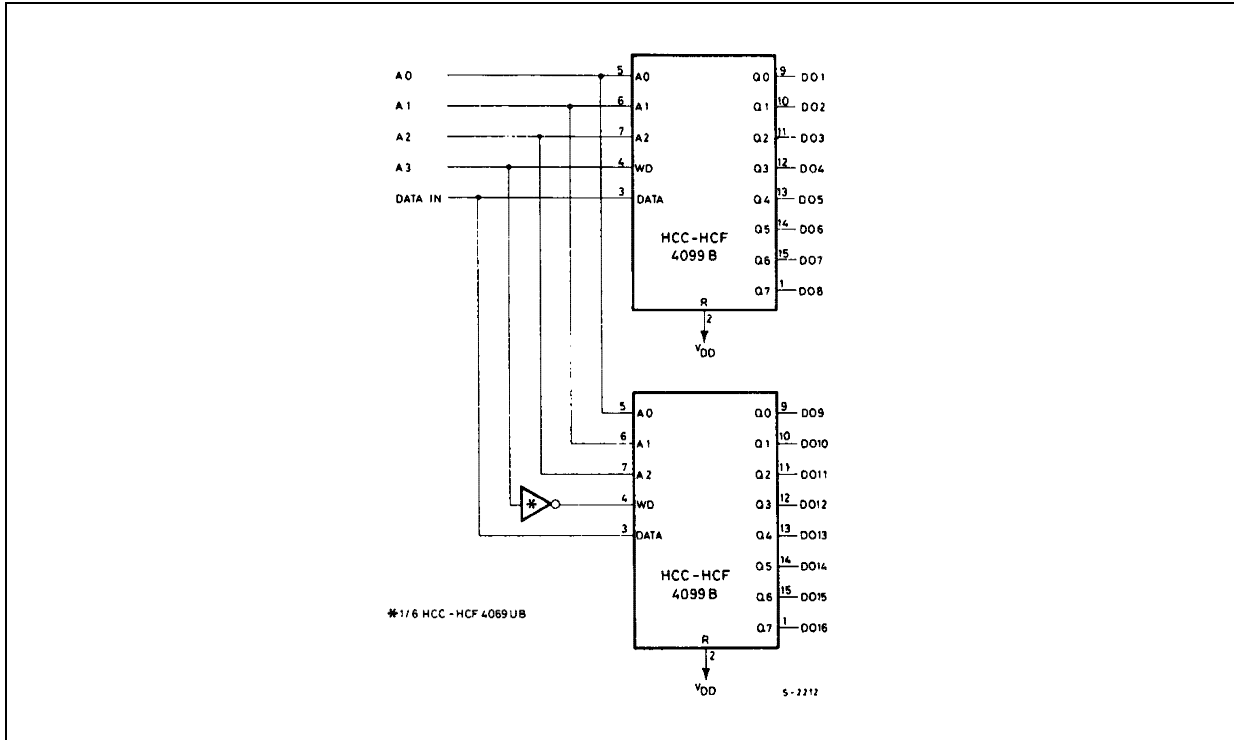

Plastic DIP-16 (0.25) MECHANICAL DATA

DIM.	mm.			inch		
	MIN.	TYP.	MAX.	MIN.	TYP.	MAX.
a1	0.51			0.020		
B	0.77		1.65	0.030		0.065
b		0.5			0.020	
b1		0.25			0.010	
D			20			0.787
E		8.5			0.335	
e		2.54			0.100	
e3		17.78			0.700	
F			7.1			0.280
l			5.1			0.201
L		3.3			0.130	
Z			1.27			0.050

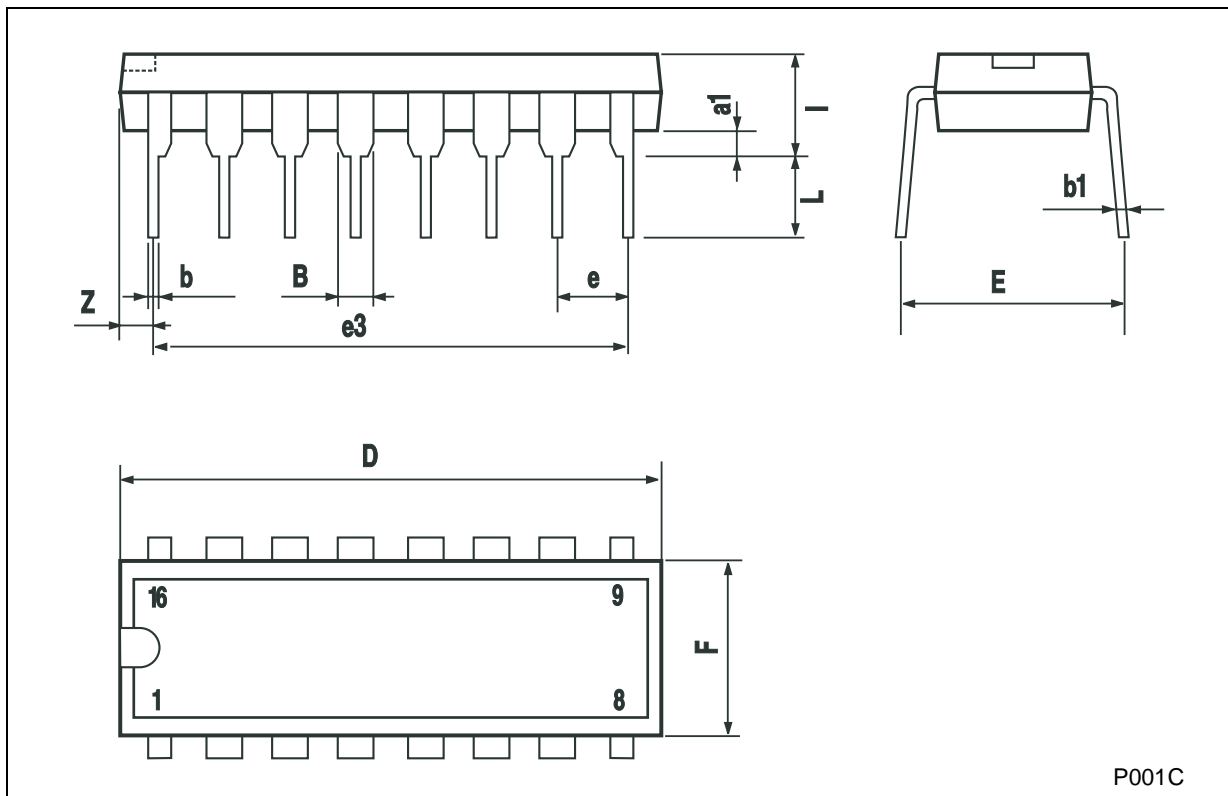

P001C

SO-16 MECHANICAL DATA

DIM.	mm.			inch		
	MIN.	TYP	MAX.	MIN.	TYP.	MAX.
A			1.75			0.068
a1	0.1		0.2	0.003		0.007
a2			1.65			0.064
b	0.35		0.46	0.013		0.018
b1	0.19		0.25	0.007		0.010
C		0.5			0.019	
c1	45° (typ.)					
D	9.8		10	0.385		0.393
E	5.8		6.2	0.228		0.244
e		1.27			0.050	
e3		8.89			0.350	
F	3.8		4.0	0.149		0.157
G	4.6		5.3	0.181		0.208
L	0.5		1.27	0.019		0.050
M			0.62			0.024
S	8° (max.)					

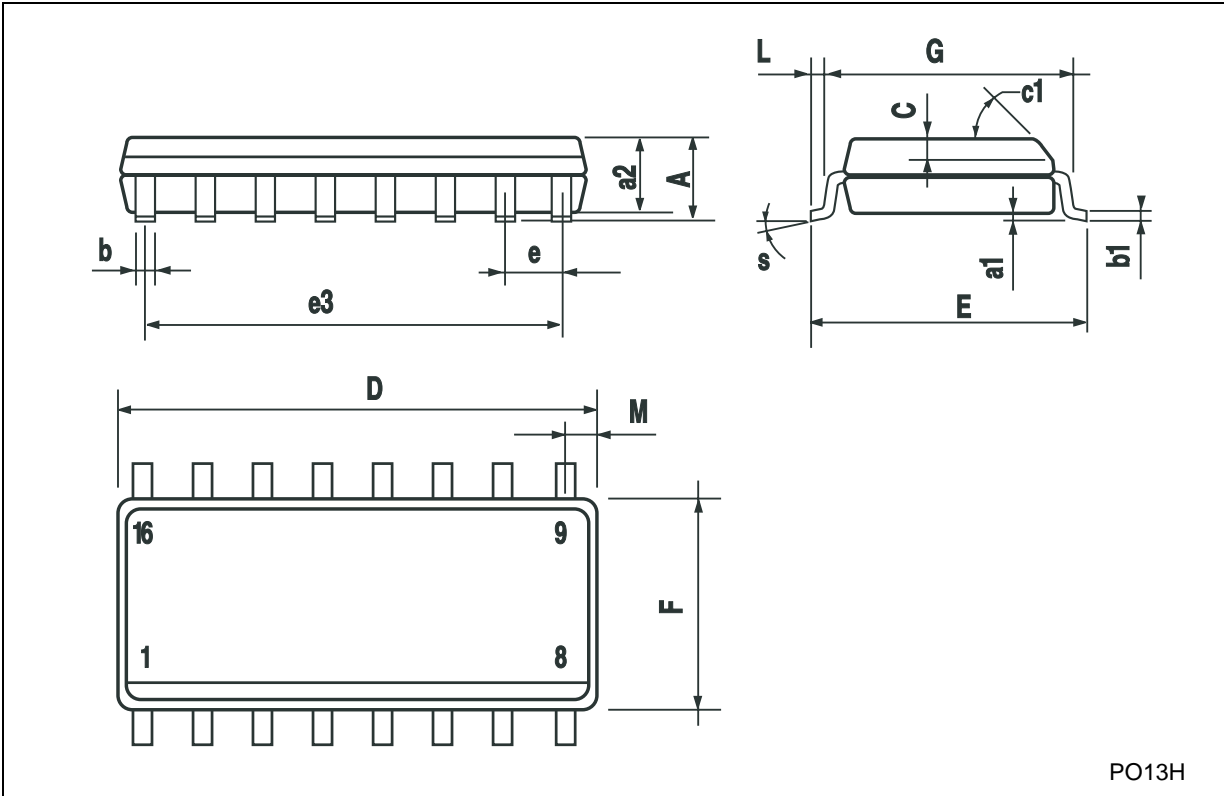

PO13H

Information furnished is believed to be accurate and reliable. However, STMicroelectronics assumes no responsibility for the consequences of use of such information nor for any infringement of patents or other rights of third parties which may result from its use. No license is granted by implication or otherwise under any patent or patent rights of STMicroelectronics. Specifications mentioned in this publication are subject to change without notice. This publication supersedes and replaces all information previously supplied. STMicroelectronics products are not authorized for use as critical components in life support devices or systems without express written approval of STMicroelectronics.

© The ST logo is a registered trademark of STMicroelectronics

© 2002 STMicroelectronics - Printed in Italy - All Rights Reserved
STMicroelectronics GROUP OF COMPANIES

Australia - Brazil - Canada - China - Finland - France - Germany - Hong Kong - India - Israel - Italy - Japan - Malaysia - Malta - Morocco
Singapore - Spain - Sweden - Switzerland - United Kingdom - United States.

© <http://www.st.com>