



Data sheet acquired from Harris Semiconductor
SCHS178C

January 1998 - Revised May 2003

CD54HC299, CD74HC299, CD54HCT299, CD74HCT299

High-Speed CMOS Logic 8-Bit Universal Shift Register; Three-State

Features

- Buffered Inputs
- Four Operating Modes: Shift Left, Shift Right, Load and Store
- Can be Cascaded for N-Bit Word Lengths
- I/O₀ - I/O₇ Bus Drive Capability and Three-State for Bus Oriented Applications
- Typical f_{MAX} = 50MHz at V_{CC} = 5V, C_L = 15pF, T_A = 25°C
- Fanout (Over Temperature Range)
 - Standard Outputs 10 LSTTL Loads
 - Bus Driver Outputs 15 LSTTL Loads
- Wide Operating Temperature Range . . . -55°C to 125°C
- Balanced Propagation Delay and Transition Times
- Significant Power Reduction Compared to LSTTL Logic ICs
- HC Types
 - 2V to 6V Operation
 - High Noise Immunity: N_{IL} = 30%, N_{IH} = 30% of V_{CC} at V_{CC} = 5V
- HCT Types
 - 4.5V to 5.5V Operation
 - Direct LSTTL Input Logic Compatibility, V_{IL} = 0.8V (Max), V_{IH} = 2V (Min)
 - CMOS Input Compatibility, I_I ≤ 1μA at V_{OL}, V_{OH}

Description

The 'HC259 and 'HCT299 are 8-bit shift/storage registers with three-state bus interface capability. The register has four synchronous-operating modes controlled by the two select inputs as shown in the mode select (S0, S1) table. The mode select, the serial data (DS0, DS7) and the parallel data (I/O₀ - I/O₇) respond only to the low-to-high transition of the clock (CP) pulse. S0, S1 and data inputs must be stable one set-up time prior to the clock positive transition.

The Master Reset (\overline{MR}) is an asynchronous active low input. When \overline{MR} output is low, the register is cleared regardless of the status of all other inputs. The register can be expanded by cascading same units by tying the serial output (Q0) to the serial data (DS7) input of the preceding register, and tying the serial output (Q7) to the serial data (DS0) input of the following register. Recirculating the (n x 8) bits is accomplished by tying the Q7 of the last stage to the DS0 of the first stage.

The three-state input/output I(/O) port has three modes of operation:

1. Both output enable ($\overline{OE1}$ and $\overline{OE2}$) inputs are low and S0 or S1 or both are low, the data in the register is presented at the eight outputs.
2. When both S0 and S1 are high, I/O terminals are in the high impedance state but being input ports, ready for parallel data to be loaded into eight registers with one clock transition regardless of the status of $\overline{OE1}$ and $\overline{OE2}$.
3. Either one of the two output enable inputs being high will force I/O terminals to be in the off-state. It is noted that each I/O terminal is a three-state output and a CMOS buffer input.

Pinout

CD54HC299, CD54HCT299
(CERDIP)
CD74HC299, CD74HCT299
(PDIP, SOIC)
TOP VIEW

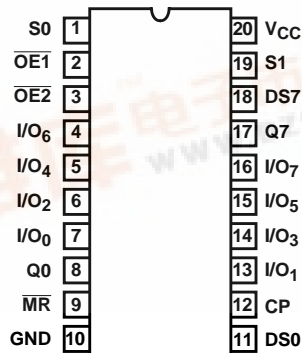

Ordering Information

PART NUMBER	TEMP. RANGE (°C)	PACKAGE
CD54HC299F3A	-55 to 125	20 Ld CERDIP
CD54HCT299F3A	-55 to 125	20 Ld CERDIP
CD74HC299E	-55 to 125	20 Ld PDIP
CD74HC299M	-55 to 125	20 Ld SOIC
CD74HC299M96	-55 to 125	20 Ld SOIC
CD74HCT299E	-55 to 125	20 Ld PDIP
CD74HCT299M	-55 to 125	20 Ld SOIC
CD74HCT299M96	-55 to 125	20 Ld SOIC

NOTE: When ordering, use the entire part number. The suffix 96 denotes tape and reel.



CD54HC299, CD74HC299, CD54HCT299, CD74HCT299

Functional Diagram

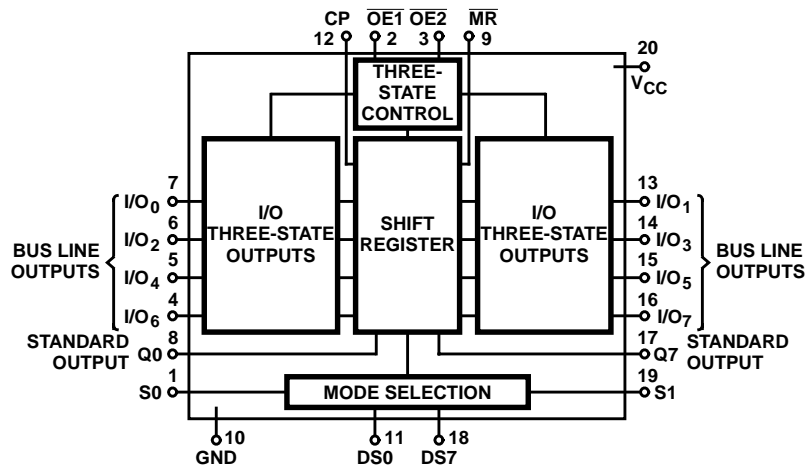

MODE SELECT FUNCTION TABLE THREE-STATE I/O PORT OPERATING MODE

FUNCTION	INPUTS					INPUTS/OUTPUTS
	OE1	OE2	S0	S1	Qn (REGISTER)	I/O0 --- I/O7
Read Register	L	L	L	X	L	L
	L	L	L	X	H	H
	L	L	X	L	L	L
	L	L	X	L	H	H
Load Register	X	X	H	H	Qn = I/On	I/On = Inputs
Disable I/O	H	X	X	X	X	(Z)
	X	H	X	X	X	(Z)

TRUTH TABLE

FUNCTION	INPUTS							REGISTER OUTPUTS				
	MR	CP	S0	S1	DS0	DS7	I/On	Q0	Q1	---	Q6	Q7
RESET (CLEAR)	L	X	X	X	X	X	X	L	L	---	L	L
Shift Right	H	↑	h	l	l	X	X	L	q0	---	q5	q6
	H	↑	h	l	h	X	X	H	q0	---	q5	Q6
Shift Left	H	↑	l	h	X	l	X	q1	q2	---	q7	L
	H	↑	l	h	X	h	X	q1	q2	---	q7	H
Hold (Do Nothing)	H	↑	l	l	X	X	X	q0	q1	---	q6	q7
Parallel Load	H	↑	h	h	X	X	l	L	L	---	L	L
	H	↑	h	h	X	X	h	H	H	---	H	H

H = Input Voltage High Level, h = Input voltage high one set-up timer prior clock transition; L = Input Voltage Low Level; l = Input voltage low one set-up time prior to clock transition; qn = Lower case letter indicates the state of the reference output one set-up time prior to clock transition; X - Voltage level on logic status don't care; Z = Output in high impedance state, ↑ = Low to High Clock Transition.

CD54HC299, CD74HC299, CD54HCT299, CD74HCT299

Absolute Maximum Ratings

DC Supply Voltage, V_{CC}	-0.5V to 7V
DC Input Diode Current, I_{IK}	
For $V_I < -0.5V$ or $V_I > V_{CC} + 0.5V$	$\pm 20mA$
DC Output Diode Current, I_{OK}	
For $V_O < -0.5V$ or $V_O > V_{CC} + 0.5V$	$\pm 20mA$
DC Drain Current, per Output, I_O , For $-0.5V < V_O < V_{CC} + 0.5V$	
For Q Outputs	$\pm 25mA$
For I/O Outputs	$\pm 35mA$
DC Output Source or Sink Current per Output Pin, I_O	
For $V_O > -0.5V$ or $V_O < V_{CC} + 0.5V$	$\pm 25mA$
DC V_{CC} or Ground Current, I_{CC}	$\pm 50mA$

Thermal Information

Thermal Resistance (Typical, Note 1)	θ_{JA} ($^{\circ}C/W$)
E (PDIP) Package	69
M (SOIC) Package	58
Maximum Junction Temperature	$150^{\circ}C$
Maximum Storage Temperature Range	$-65^{\circ}C$ to $150^{\circ}C$
Maximum Lead Temperature (Soldering 10s)	$300^{\circ}C$ (SOIC - Lead Tips Only)

Operating Conditions

Temperature Range, T_A	$-55^{\circ}C$ to $125^{\circ}C$
Supply Voltage Range, V_{CC}	
HC Types2V to 6V
HCT Types	4.5V to 5.5V
DC Input or Output Voltage, V_I , V_O	0V to V_{CC}
Input Rise and Fall Time	
2V	1000ns (Max)
4.5V	500ns (Max)
6V	400ns (Max)

CAUTION: Stresses above those listed in "Absolute Maximum Ratings" may cause permanent damage to the device. This is a stress only rating and operation of the device at these or any other conditions above those indicated in the operational sections of this specification is not implied.

NOTE:

- The package thermal impedance is calculated in accordance with JESD 51-7.

DC Electrical Specifications

PARAMETER	SYMBOL	TEST CONDITIONS		V_{CC} (V)	25 $^{\circ}C$			-40 $^{\circ}C$ TO 85 $^{\circ}C$		-55 $^{\circ}C$ TO 125 $^{\circ}C$		UNITS		
		V_I (V)	I_O (mA)		MIN	TYP	MAX	MIN	MAX	MIN	MAX			
HC TYPES														
High Level Input Voltage	V_{IH}	-	-	2	1.5	-	-	1.5	-	1.5	-	V		
				4.5	3.15	-	-	3.15	-	3.15	-	V		
				6	4.2	-	-	4.2	-	4.2	-	V		
Low Level Input Voltage	V_{IL}	-	-	2	-	-	0.5	-	0.5	-	0.5	V		
				4.5	-	-	1.35	-	1.35	-	1.35	V		
				6	-	-	1.8	-	1.8	-	1.8	V		
High Level Output Voltage CMOS Loads	V_{OH}	V_{IH} or V_{IL}	-0.02	2	1.9	-	-	1.9	-	1.9	-	V		
				4.5	4.4	-	-	4.4	-	4.4	-	V		
				6	5.9	-	-	5.9	-	5.9	-	V		
High Level Output Voltage TTL Loads	V_{OH}	V_{IH} or V_{IL}	-0.02	Qn	I/On	-	-	-	-	-	-	V		
				-4	-6	4.5	3.98	-	-	3.84	-	3.7	-	V
				-5.2	-7.8	6	5.48	-	-	5.34	-	5.2	-	V
Low Level Output Voltage CMOS Loads	V_{OL}	V_{IH} or V_{IL}	0.02	2	-	-	0.1	-	0.1	-	0.1	V		
				4.5	-	-	0.1	-	0.1	-	0.1	V		
				6	-	-	0.1	-	0.1	-	0.1	V		
Low Level Output Voltage TTL Loads	V_{OL}	V_{IH} or V_{IL}	0.02	Qn	I/On	-	-	-	-	-	-	V		
				4	6	4.5	-	-	0.26	-	0.33	-	0.4	V
				5.2	7.8	6	-	-	0.26	-	0.33	-	0.4	V
Input Leakage Current	I_I	V_{CC} or GND	-	6	-	-	± 0.1	-	± 1	-	± 1	μA		

CD54HC299, CD74HC299, CD54HCT299, CD74HCT299

DC Electrical Specifications (Continued)

PARAMETER	SYMBOL	TEST CONDITIONS		V _{CC} (V)	25°C			-40°C TO 85°C		-55°C TO 125°C		UNITS
		V _I (V)	I _O (mA)		MIN	TYP	MAX	MIN	MAX	MIN	MAX	
Quiescent Device Current	I _{CC}	V _{CC} or GND	0	6	-	-	8	-	80	-	160	μA
Three- State Leakage Current	V _{IL} or V _{IH}	V _O =V _{CC} or GND	-	6	-	-	±0.5	-	±5	-	±10	μA
HCT TYPES												
High Level Input Voltage	V _{IH}	-	-	4.5 to 5.5	2	-	-	2	-	2	-	V
Low Level Input Voltage	V _{IL}	-	-	4.5 to 5.5	-	-	0.8	-	0.8	-	0.8	V
High Level Output Voltage CMOS Loads	V _{OH}	V _{IH} or V _{IL}	-0.02	4.5	4.4	-	-	4.4	-	4.4	-	V
High Level Output Voltage TTL Loads			-4	4.5	3.98	-	-	3.84	-	3.7	-	V
Low Level Output Voltage CMOS Loads	V _{OL}	V _{IH} or V _{IL}	0.02	4.5	-	-	0.1	-	0.1	-	0.1	V
Low Level Output Voltage TTL Loads			4	4.5	-	-	0.26	-	0.33	-	0.4	V
Input Leakage Current	I _I	V _{CC} and GND	0	5.5	-	-	±0.1	-	±1	-	±1	μA
Quiescent Device Current	I _{CC}	V _{CC} or GND	0	5.5	-	-	8	-	80	-	160	μA
Three- State Leakage Current	V _{IL} or V _{IH}	V _O =V _{CC} or GND	-	6	-	-	±0.5	-	±5	-	±10	μA
Additional Quiescent Device Current Per Input Pin: 1 Unit Load	ΔI _{CC} (Note 2)	V _{CC} -2.1	-	4.5 to 5.5	-	100	360	-	450	-	490	μA

NOTE:

- For dual-supply systems theoretical worst case (V_I = 2.4V, V_{CC} = 5.5V) specification is 1.8mA.

HCT Input Loading Table

INPUT	UNIT LOADS
S1, MR	0.25
I/O ₀ - I/O ₇	0.25
DS0, DS7	0.25
S0, CP	0.6
OE1, OE2	0.3

NOTE: Unit Load is ΔI_{CC} limit specific in Static Specifications Table, e.g., 360μA max. at 25°C.

CD54HC299, CD74HC299, CD54HCT299, CD74HCT299

Prerequisite for Switching Specifications

PARAMETER	SYMBOL	V _{CC} (V)	25°C			-40°C TO 85°C			-55°C TO 125°C			UNITS
			MIN	TYP	MAX	MIN	TYP	MAX	MIN	TYP	MAX	
HC TYPES												
Maximum Clock Frequency	f _{MAX}	2	6	-	-	5	-	-	4	-	-	MHz
		4.5	30	-	-	25	-	-	20	-	-	MHz
		6	35	-	-	29	-	-	23	-	-	MHz
MR Pulse Width	t _W	2	50	-	-	65	-	-	75	-	-	ns
		4.5	10	-	-	13	-	-	15	-	-	ns
		6	9	-	-	11	-	-	13	-	-	ns
Clock Pulse Width	t _W	2	80	-	-	100	-	-	120	-	-	ns
		4.5	16	-	-	20	-	-	24	-	-	ns
		6	14	-	-	17	-	-	20	-	-	ns
Setup Time DS0, DS7, I/On to Clock	t _{SU}	2	100	-	-	125	-	-	150	-	-	ns
		4.5	20	-	-	25	-	-	30	-	-	ns
		6	17	-	-	21	-	-	26	-	-	ns
Hold Time DS0, DS7, I/On, S0, S1 to Clock	t _H	2	0	-	-	0	-	-	0	-	-	ns
		4.5	0	-	-	0	-	-	0	-	-	ns
		6	0	-	-	0	-	-	0	-	-	ns
Recovery Time MR to Clock	t _{REC}	2	5	-	-	5	-	-	5	-	-	ns
		4.5	5	-	-	5	-	-	5	-	-	ns
		6	5	-	-	5	-	-	5	-	-	ns
Setup Time S1, S0 to Clock	t _{SU}	2	120	-	-	150	-	-	180	-	-	ns
		4.5	24	-	-	30	-	-	36	-	-	ns
		6	20	-	-	26	-	-	31	-	-	ns
HCT TYPES												
Maximum Clock Frequency	f _{MAX}	4.5	25	-	-	20	-	-	16	-	-	MHz
MR Pulse Width	t _W	4.5	15	-	-	19	-	-	22	-	-	ns
Clock Pulse Width	t _W	4.5	20	-	-	25	-	-	30	-	-	ns
Setup Time DS0, DS7, I/On, S0, S1 to Clock	t _{SU}	4.5	20	-	-	25	-	-	30	-	-	ns
Hold Time DS0, DS7, I/On, S0, S1 to Clock	t _H	4.5	0	-	-	0	-	-	0	-	-	ns
Recovery Time MR to Clock	t _{REC}	4.5	5	-	-	5	-	-	5	-	-	ns
Setup Time S1, S0 to Clock	t _{SU}	4.5	27	-	-	34	-	-	41	-	-	ns

CD54HC299, CD74HC299, CD54HCT299, CD74HCT299

Switching Specifications $C_L = 50\text{pF}$, Input $t_r, t_f = 6\text{ns}$

PARAMETER	SYMBOL	TEST CONDITIONS	V_{CC} (V)	25°C			-40°C TO 85°C		-55°C TO 125°C		UNITS
				MIN	TYP	MAX	MIN	MAX	MIN	MAX	
HC TYPES											
Propagation Delay Clock to I/O Output, Clock to Q0 and Q7, MR to Output	t_{PLH}, t_{PHL}	$C_L = 50\text{pF}$	2	-	-	200	-	250	-	300	ns
			4.5	-	-	40	-	50	-	60	ns
		$C_L = 15\text{pF}$	5	-	17	-	-	-	-	-	ns
		$C_L = 50\text{pF}$	6	-	-	34	-	43	-	51	ns
Output Enable and Disable Times	t_{PZL}	$C_L = 15\text{pF}$	5	-	10	-	-	-	-	-	ns
	t_{PZH}, t_{PLZ}		-	13	-	-	-	-	-	-	ns
	t_{PHZ}		-	15	-	-	-	-	-	-	ns
Output High-Z to High Level	t_{PZH}	$C_L = 50\text{pF}$	2	-	-	155	-	195	-	235	ns
			4.5	-	-	31	-	39	-	47	ns
			6	-	-	26	-	33	-	40	ns
Output High Level to High-Z	t_{PHZ}	$C_L = 50\text{pF}$	2	-	-	185	-	230	-	280	ns
			4.5	-	-	37	-	46	-	56	ns
			6	-	-	31	-	39	-	48	ns
Output Low Level to High-Z	t_{PLZ}	$C_L = 50\text{pF}$	2	-	-	155	-	195	-	235	ns
			4.5	-	-	31	-	39	-	47	ns
			6	-	-	26	-	33	-	40	ns
Output High-Z to Low Level	t_{PZL}	$C_L = 50\text{pF}$	2	-	-	130	-	165	-	195	ns
			4.5	-	-	26	-	33	-	39	ns
			6	-	-	22	-	28	-	33	ns
Output Transition Time Q0, Q7	t_{THL}, t_{TLH}	$C_L = 50\text{pF}$	2	-	-	75	-	95	-	110	ns
			4.5	-	-	15	-	19	-	22	ns
			6	-	-	13	-	16	-	19	ns
I/O ₀ to I/O ₇	t_{THL}, t_{TLH}	$C_L = 50\text{pF}$	2	-	-	60	-	75	-	90	ns
			4.5	-	-	12	-	15	-	18	ns
			6	-	-	10	-	13	-	15	ns
Input Capacitance	C_I	$C_L = 50\text{pF}$	-	10	-	10	-	10	-	10	pF
Three-State Output Capacitance	C_O	-	-	20	-	20	-	20	-	20	pF
Power Dissipation Capacitance (Notes 3, 4)	C_{PD}	$C_L = 15\text{pF}$	5	-	150	-	-	-	-	-	pF

CD54HC299, CD74HC299, CD54HCT299, CD74HCT299

Switching Specifications $C_L = 50\text{pF}$, Input $t_r, t_f = 6\text{ns}$ (Continued)

PARAMETER	SYMBOL	TEST CONDITIONS	V_{CC} (V)	25°C			-40°C TO 85°C		-55°C TO 125°C		UNITS
				MIN	TYP	MAX	MIN	MAX	MIN	MAX	
HCT TYPES											
Propagation Delay Clock to I/O Output, Clock to Q0 and Q7	t_{PHL}, t_{PLH}	$C_L = 50\text{pF}$	4.5	-	-	45	-	56	-	68	ns
		$C_L = 15\text{pF}$	5	-	19	-	-	-	-	-	ns
\overline{MR} to Output	t_{PHL}, t_{PLH}	$C_L = 50\text{pF}$	4.5	-	-	46	-	58	-	69	ns
Output Enable and Disable Times	$t_{PZL}, t_{PZH}, t_{PLZ}, t_{PHZ}$	$C_L = 15\text{pF}$	5	-	10, 13, 15	-	-	-	-	-	ns
Output High-Z to High Level	t_{PZH}	$C_L = 50\text{pF}$	4.5	-	-	32	-	40	-	48	ns
Output High Level to High-Z	t_{PHZ}	$C_L = 50\text{pF}$	4.5	-	-	37	-	46	-	56	ns
Output Low Level to High-Z	t_{PLZ}	$C_L = 50\text{pF}$	4.5	-	-	32	-	40	-	48	ns
Output High-Z to Low Level	t_{PZL}	$C_L = 50\text{pF}$	4.5	-	-	30	-	38	-	45	ns
Output Transition Time Q0, Q7 I/O ₀ to I/O ₇	t_{TLH}, t_{THL}	$C_L = 50\text{pF}$	4.5	-	-	15	-	19	-	22	ns
		$C_L = 50\text{pF}$	4.5	-	-	12	-	15	-	18	ns
Input Capacitance	C_{IN}	$C_L = 50\text{pF}$	-	10	-	10	-	10	-	10	pF
Three-State Output Capacitance	C_O	-	-	20	-	20	-	20	-	20	pF
Power Dissipation Capacitance (Notes 3, 4)	C_{PD}	$C_L = 15\text{pF}$	5	-	170	-	-	-	-	-	pF

NOTES:

- C_{PD} is used to determine the dynamic power consumption, per register.
- $P_D = C_{PD} V_{CC}^2 f_i + \sum (C_L V_{CC}^2 f_O)$ where f_i = Input Frequency, f_O = Output Frequency, C_L = Output Load Capacitance, V_{CC} = Supply Voltage.

Test Circuits and Waveforms

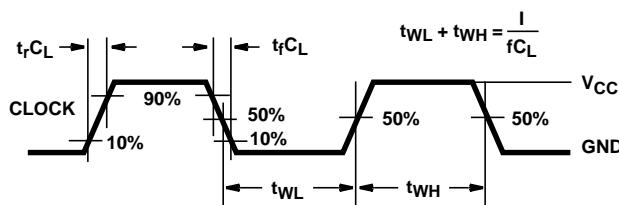

NOTE: Outputs should be switching from 10% V_{CC} to 90% V_{CC} in accordance with device truth table. For f_{MAX} , input duty cycle = 50%.

FIGURE 1. HC CLOCK PULSE RISE AND FALL TIMES AND PULSE WIDTH

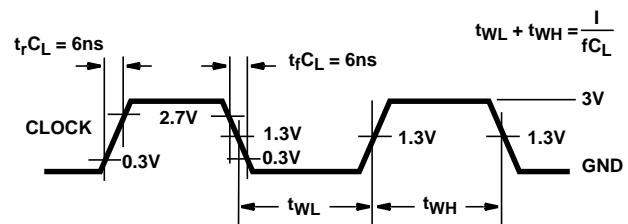

NOTE: Outputs should be switching from 10% V_{CC} to 90% V_{CC} in accordance with device truth table. For f_{MAX} , input duty cycle = 50%.

FIGURE 2. HCT CLOCK PULSE RISE AND FALL TIMES AND PULSE WIDTH

CD54HC299, CD74HC299, CD54HCT299, CD74HCT299

Test Circuits and Waveforms (Continued)

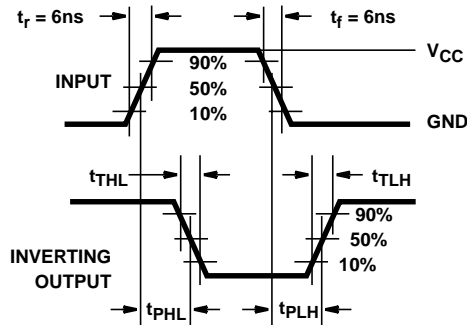

FIGURE 3. HC TRANSITION TIMES AND PROPAGATION DELAY TIMES, COMBINATION LOGIC

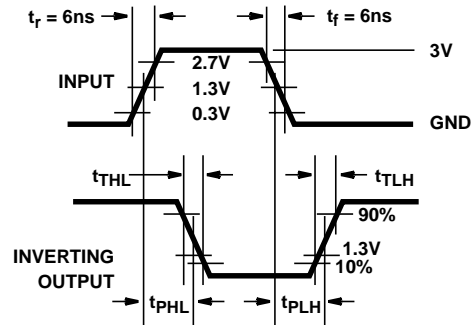

FIGURE 4. HCT TRANSITION TIMES AND PROPAGATION DELAY TIMES, COMBINATION LOGIC

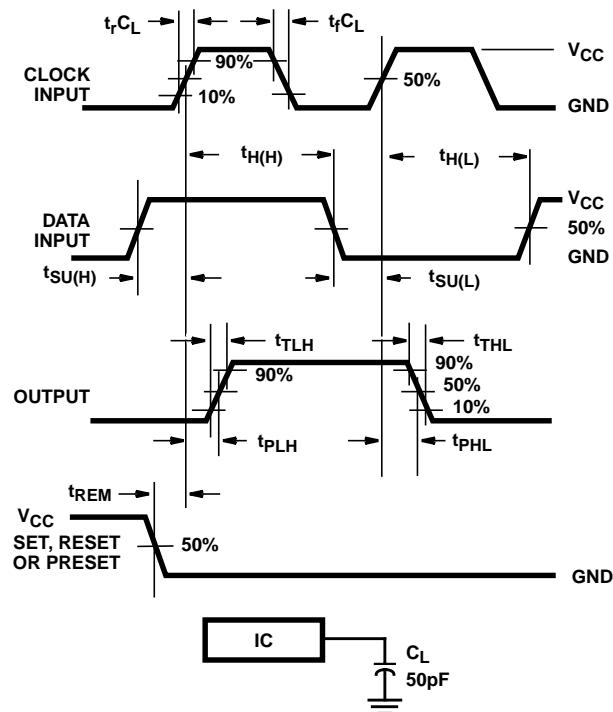

FIGURE 5. HC SETUP TIMES, HOLD TIMES, REMOVAL TIME, AND PROPAGATION DELAY TIMES FOR EDGE TRIGGERED SEQUENTIAL LOGIC CIRCUITS

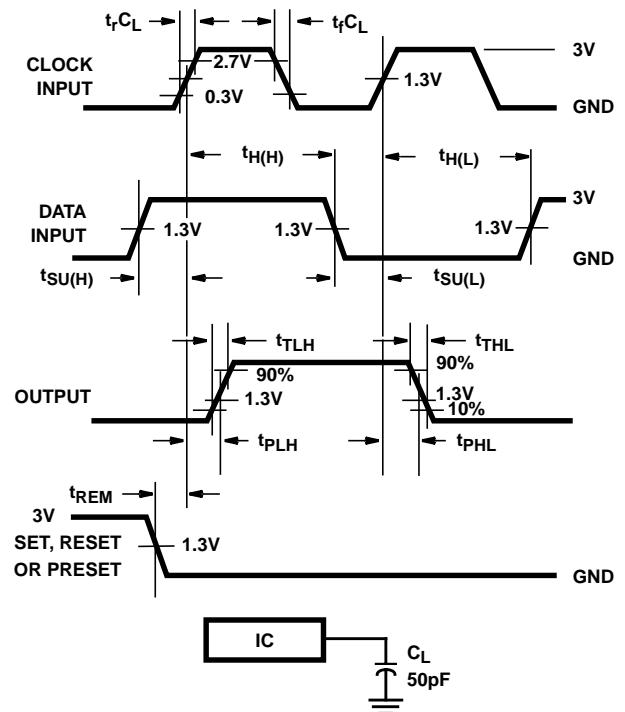

FIGURE 6. HCT SETUP TIMES, HOLD TIMES, REMOVAL TIME, AND PROPAGATION DELAY TIMES FOR EDGE TRIGGERED SEQUENTIAL LOGIC CIRCUITS

CD54HC299, CD74HC299, CD54HCT299, CD74HCT299

Test Circuits and Waveforms (Continued)

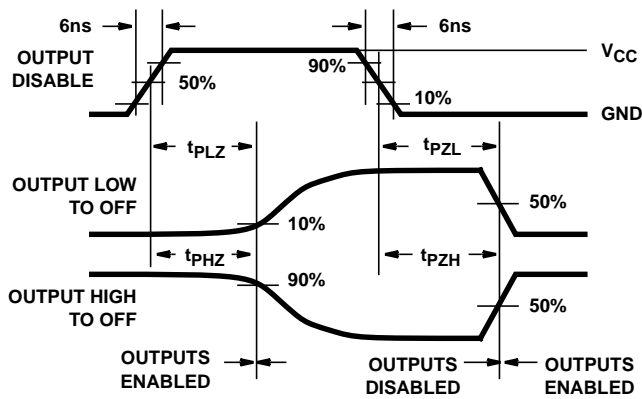

FIGURE 7. HC THREE-STATE PROPAGATION DELAY WAVEFORM

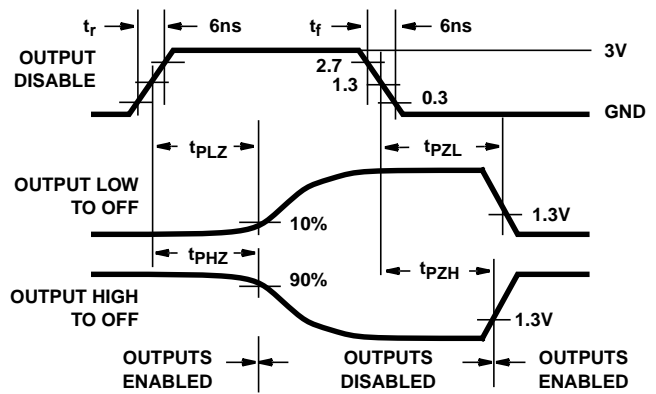
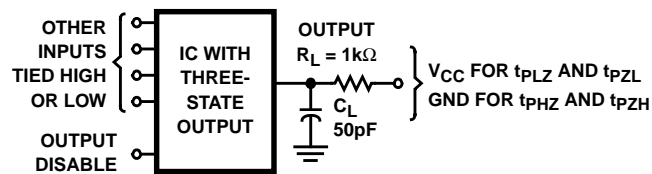

FIGURE 8. HCT THREE-STATE PROPAGATION DELAY WAVEFORM



NOTE: Open drain waveforms t_{pLZ} and t_{pZL} are the same as those for three-state shown on the left. The test circuit is Output $R_L = 1k\Omega$ to V_{CC} , $C_L = 50pF$.

FIGURE 9. HC AND HCT THREE-STATE PROPAGATION DELAY TEST CIRCUIT

J (R-GDIP-T**)

14 LEADS SHOWN

CERAMIC DUAL IN-LINE PACKAGE

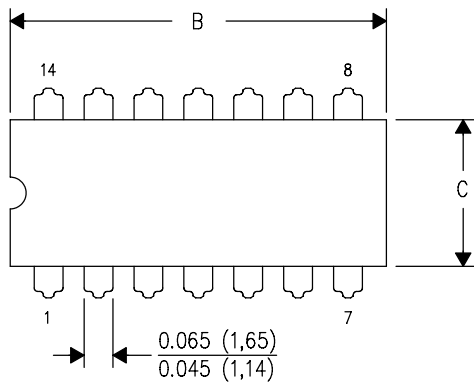

DIM \ PINS **	14	16	18	20
A	0.300 (7,62) BSC	0.300 (7,62) BSC	0.300 (7,62) BSC	0.300 (7,62) BSC
B MAX	0.785 (19,94)	.840 (21,34)	0.960 (24,38)	1.060 (26,92)
B MIN	—	—	—	—
C MAX	0.300 (7,62)	0.300 (7,62)	0.310 (7,87)	0.300 (7,62)
C MIN	0.245 (6,22)	0.245 (6,22)	0.220 (5,59)	0.245 (6,22)

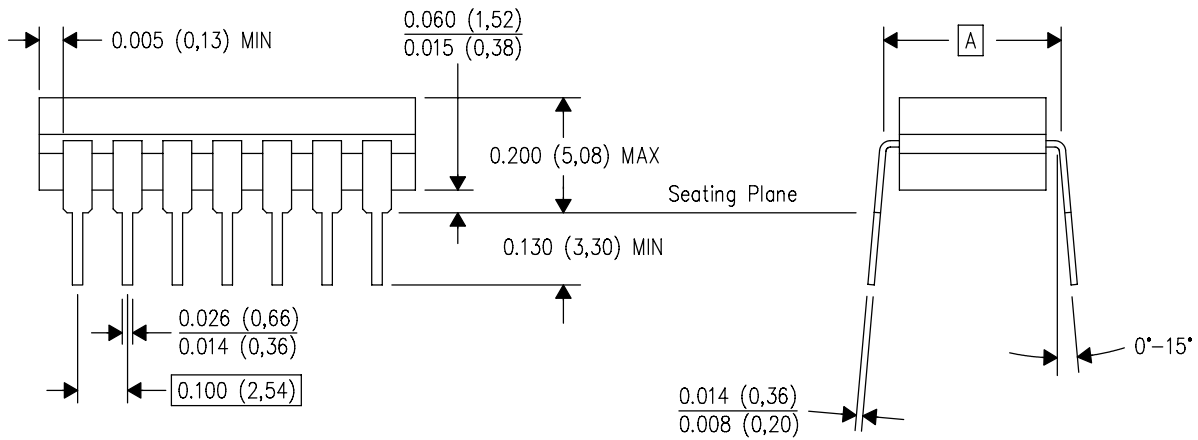

4040083/F 03/03

- NOTES:
- A. All linear dimensions are in inches (millimeters).
 - B. This drawing is subject to change without notice.
 - C. This package is hermetically sealed with a ceramic lid using glass frit.
 - D. Index point is provided on cap for terminal identification only on press ceramic glass frit seal only.
 - E. Falls within MIL STD 1835 GDIP1-T14, GDIP1-T16, GDIP1-T18 and GDIP1-T20.

MECHANICAL DATA

N (R-PDIP-T**)

16 PINS SHOWN

PLASTIC DUAL-IN-LINE PACKAGE

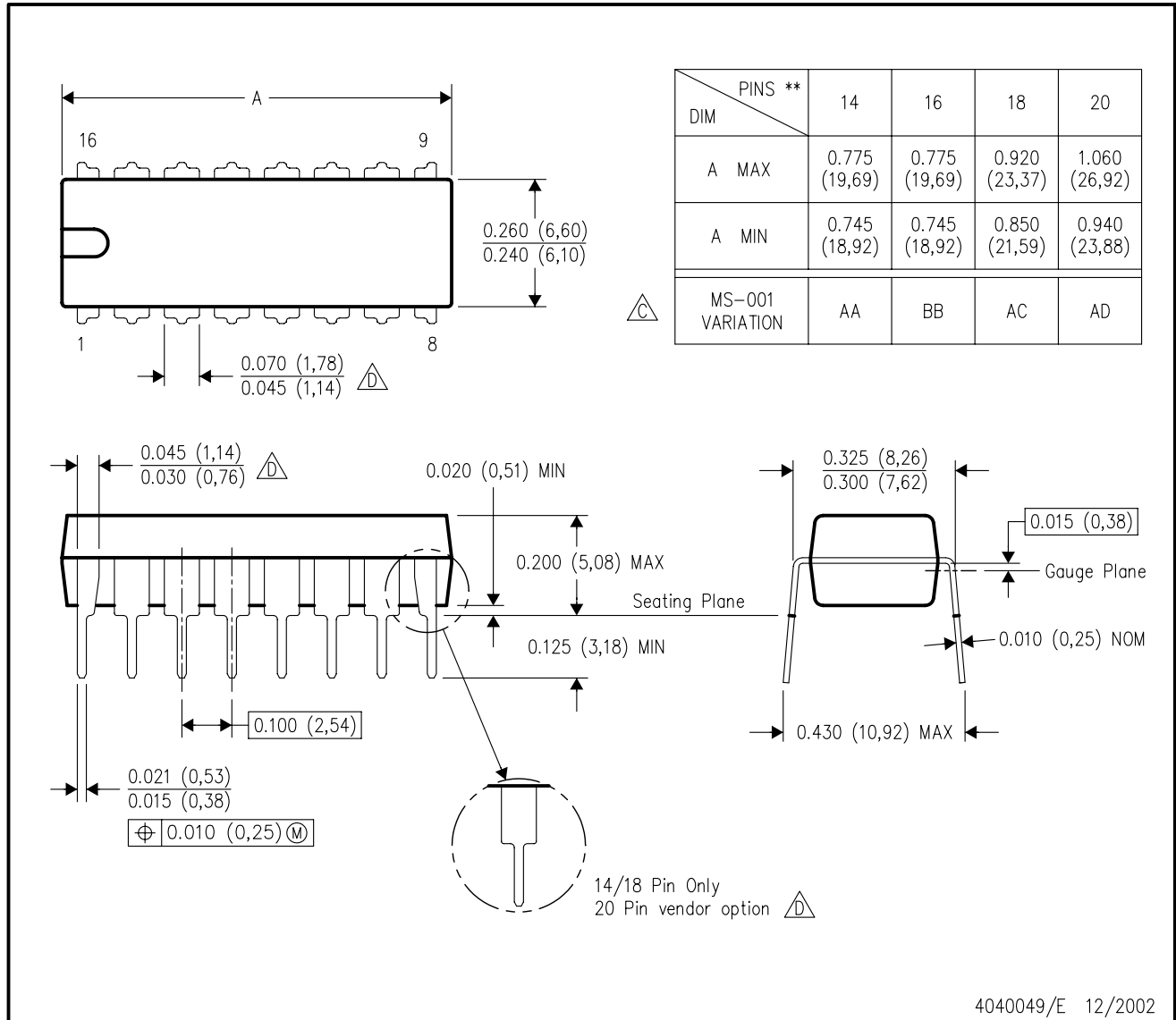

- NOTES:
- A. All linear dimensions are in inches (millimeters).
 - B. This drawing is subject to change without notice.
 - Falls within JEDEC MS-001, except 18 and 20 pin minimum body length (Dim A).
 - The 20 pin end lead shoulder width is a vendor option, either half or full width.

IMPORTANT NOTICE

Texas Instruments Incorporated and its subsidiaries (TI) reserve the right to make corrections, modifications, enhancements, improvements, and other changes to its products and services at any time and to discontinue any product or service without notice. Customers should obtain the latest relevant information before placing orders and should verify that such information is current and complete. All products are sold subject to TI's terms and conditions of sale supplied at the time of order acknowledgment.

TI warrants performance of its hardware products to the specifications applicable at the time of sale in accordance with TI's standard warranty. Testing and other quality control techniques are used to the extent TI deems necessary to support this warranty. Except where mandated by government requirements, testing of all parameters of each product is not necessarily performed.

TI assumes no liability for applications assistance or customer product design. Customers are responsible for their products and applications using TI components. To minimize the risks associated with customer products and applications, customers should provide adequate design and operating safeguards.

TI does not warrant or represent that any license, either express or implied, is granted under any TI patent right, copyright, mask work right, or other TI intellectual property right relating to any combination, machine, or process in which TI products or services are used. Information published by TI regarding third-party products or services does not constitute a license from TI to use such products or services or a warranty or endorsement thereof. Use of such information may require a license from a third party under the patents or other intellectual property of the third party, or a license from TI under the patents or other intellectual property of TI.

Reproduction of information in TI data books or data sheets is permissible only if reproduction is without alteration and is accompanied by all associated warranties, conditions, limitations, and notices. Reproduction of this information with alteration is an unfair and deceptive business practice. TI is not responsible or liable for such altered documentation.

Resale of TI products or services with statements different from or beyond the parameters stated by TI for that product or service voids all express and any implied warranties for the associated TI product or service and is an unfair and deceptive business practice. TI is not responsible or liable for any such statements.

Following are URLs where you can obtain information on other Texas Instruments products and application solutions:

Products		Applications	
Amplifiers	amplifier.ti.com	Audio	www.ti.com/audio
Data Converters	dataconverter.ti.com	Automotive	www.ti.com/automotive
DSP	dsp.ti.com	Broadband	www.ti.com/broadband
Interface	interface.ti.com	Digital Control	www.ti.com/digitalcontrol
Logic	logic.ti.com	Military	www.ti.com/military
Power Mgmt	power.ti.com	Optical Networking	www.ti.com/opticalnetwork
Microcontrollers	microcontroller.ti.com	Security	www.ti.com/security
		Telephony	www.ti.com/telephony
		Video & Imaging	www.ti.com/video
		Wireless	www.ti.com/wireless

Mailing Address: Texas Instruments
Post Office Box 655303 Dallas, Texas 75265