

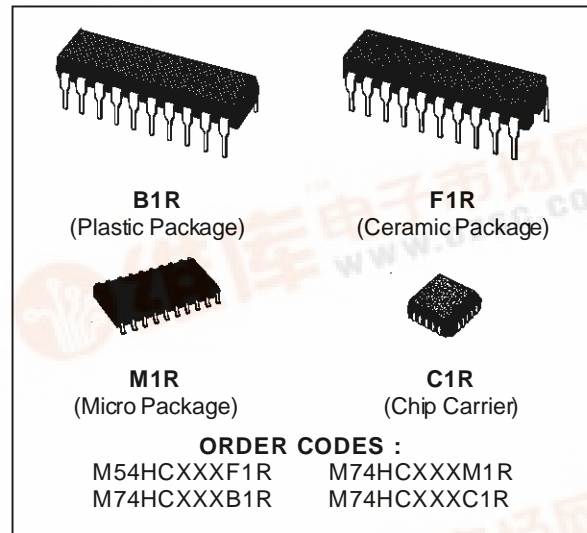

M54/74HC299 M54/74HC323

HC299 8 BIT PIPO SHIFT REGISTER WITH ASYNCHRONOUS CLEAR HC323 8 BIT PIPO SHIFT REGISTER WITH SYNCHRONOUS CLEAR

- HIGH SPEED
f_{MAX} = 42 MHz (TYP.) AT V_{CC} = 5V
- LOW POWER DISSIPATION
I_{CC} = 4 μA (MAX.) AT T_A = 25 °C
- HIGH NOISE IMMUNITY
V_{NIH} = V_{NIL} = 28 % V_{CC} (MIN.)
- OUTPUT DRIVE CAPABILITY
10 LSTTL LOADS FOR QA' TO QH'
15 LSTTL LOADS FOR QA TO QH
- SYMMETRICAL OUTPUT IMPEDANCE
|I_{OH}| = I_{OL} = 6 mA (MIN.) FOR QA, TO QH,
|I_{OH}| = I_{OL} = 4 mA (MIN.) FOR QA, TO QH
- BALANCED PROPAGATION DELAYS
t_{PLH} = t_{PHL}
- WIDE OPERATING VOLTAGE RANGE
V_{CC} (OPR) = 2 V TO 6 V
- PIN AND FUNCTION COMPATIBLE
WITH 54/74LS299



DESCRIPTION

The M54/74HC299/323 are high speed CMOS 8-BIT PIPO SHIFT REGISTERS (3-STATE) fabricated with silicon gate C²MOS technology.

They achieve the high speed operation similar to equivalent LSTTL while maintaining the CMOS low power consumption.

These devices have four modes (HOLD, SHIFT LEFT, SHIFT RIGHT and LOAD DATA). Each mode is chosen by two function select inputs (S0, S1). When one or both enable inputs, ($\overline{G1}$, $\overline{G2}$) are high, the eight input/output terminals are in the high-impedance state ; however sequential operation or clearing of the register is not affected.

Clear function on the HC299 is asynchronous to CLOCK, while the HC323 is cleared synchronous to clock.

All inputs are equipped with protection circuits against static discharge and transient excess voltage.

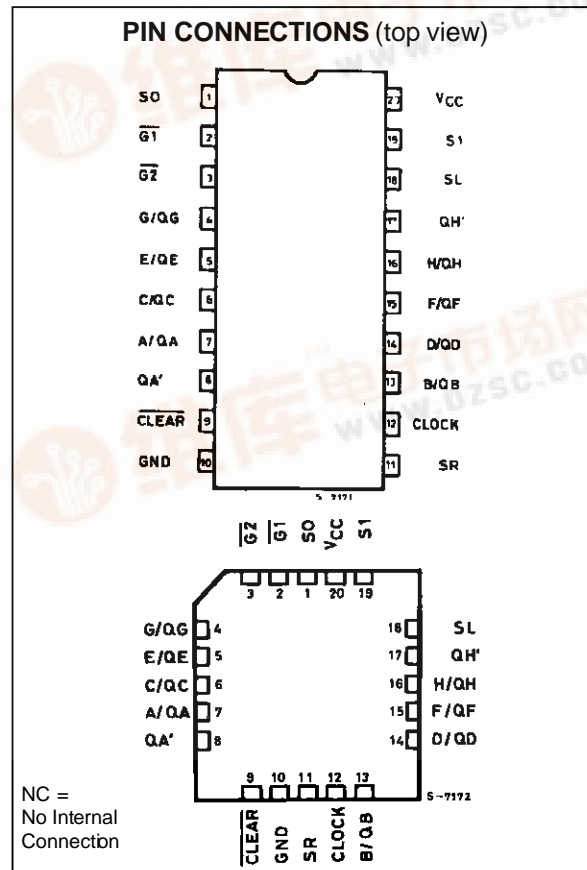

M54/M74HC299/323

INPUT AND OUTPUT EQUIVALENT CIRCUIT

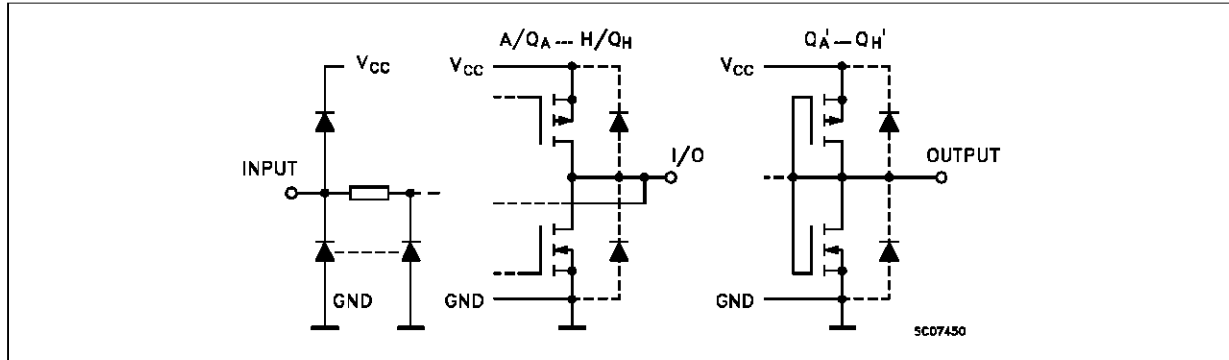

TRUTH TABLE

| MODE | INPUTS | | | | | | INPUTS/OUTPUTS | | | | OUTPUTS | | |
|-------------|--------|-------------------|----|----------------|-----|-------|----------------|--------|----|------|---------|-----|-----|
| | CLEAR | FUNCTION SELECTED | | OUTPUT CONTROL | | CLOCK | | SERIAL | | A/QA | H/QH | QA' | QH' |
| | | S1 | S0 | G1* | G2* | (299) | (323) | SL | SR | | | | |
| Z | L | H | H | X | X | X | | X | X | Z | Z | L | L |
| CLEAR | L | L | X | L | L | X | | X | X | L | L | L | L |
| | L | X | L | L | L | X | | X | X | L | L | L | L |
| HOLD | H | L | L | L | L | X | | X | X | QA0 | QH0 | QA0 | QH0 |
| SHIFT RIGHT | H | L | H | L | L | | | X | H | H | QGn | H | QGn |
| | H | L | H | L | L | | | X | L | L | QGn | L | QGn |
| SHIFT LEFT | H | H | L | L | L | | | H | X | QBn | H | QBn | H |
| | H | H | L | L | L | | | L | X | QBn | L | QBn | L |
| LOAD | H | H | H | X | X | | | X | X | a | h | a | h |

* When one or both output controls are high, the eight, input/output terminals are in the high impedance state: however sequential operation or clearing of the register is not affected.

Z : HIGH IMPEDANCE

Qn0 : THE LEVEL OF An BEFORE THE INDICATED STEADY STATE INPUT CONDITIONS WERE ESTABLISHED.

Qnn : THE LEVEL ON Qn BEFORE THE MOST RECENT ACTIVE TRANSITION INDICATED BY OR

a, h : THE LEVEL OF THE STEADY STATE INPUTS A, H, RESPECTIVELY.

X : DON'T CARE

LOGIC DIAGRAM (HC299)

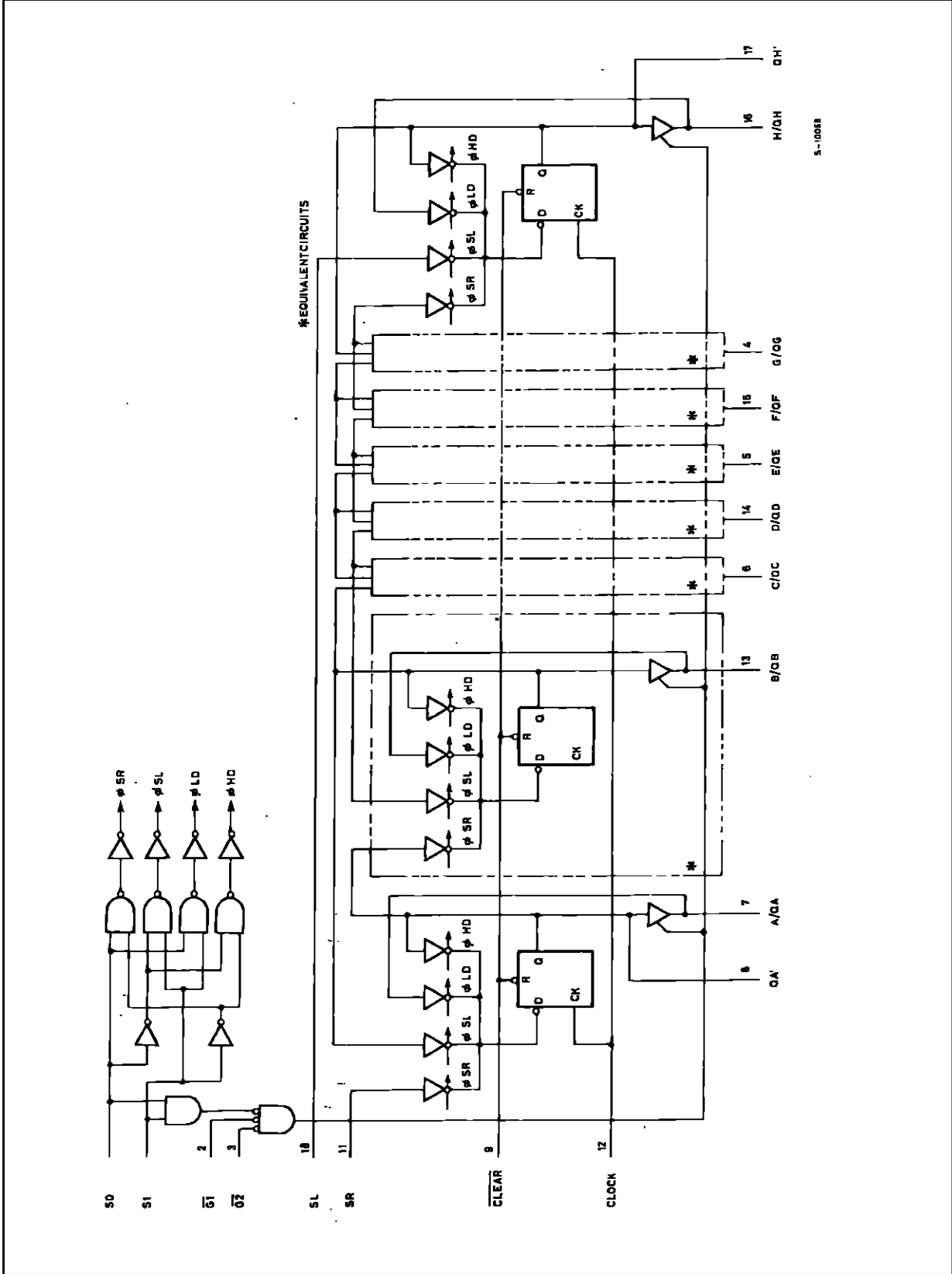

S-1005B

M54/M74HC299/323

LOGIC DIAGRAM (HC323)

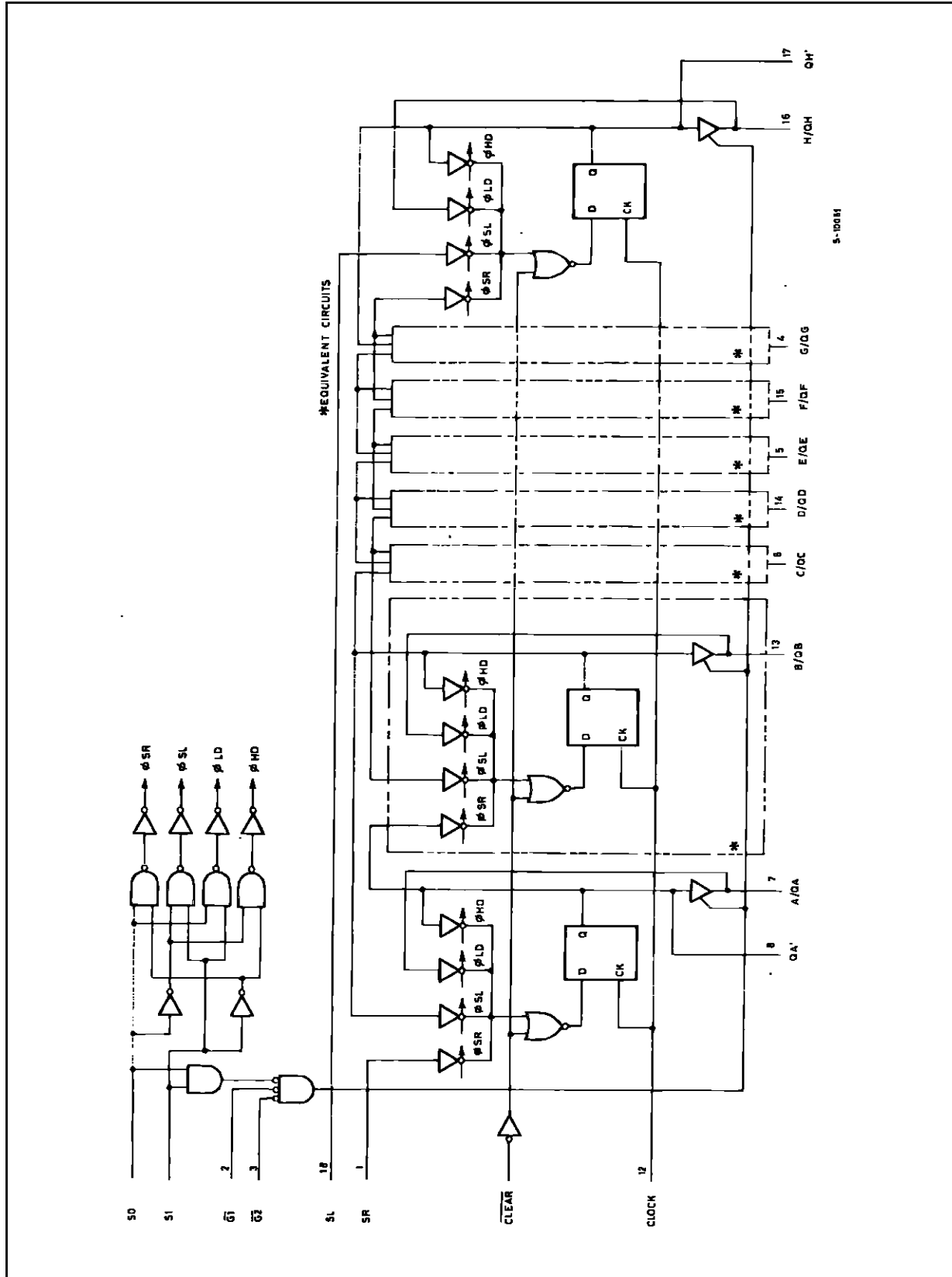

TIMING CHART

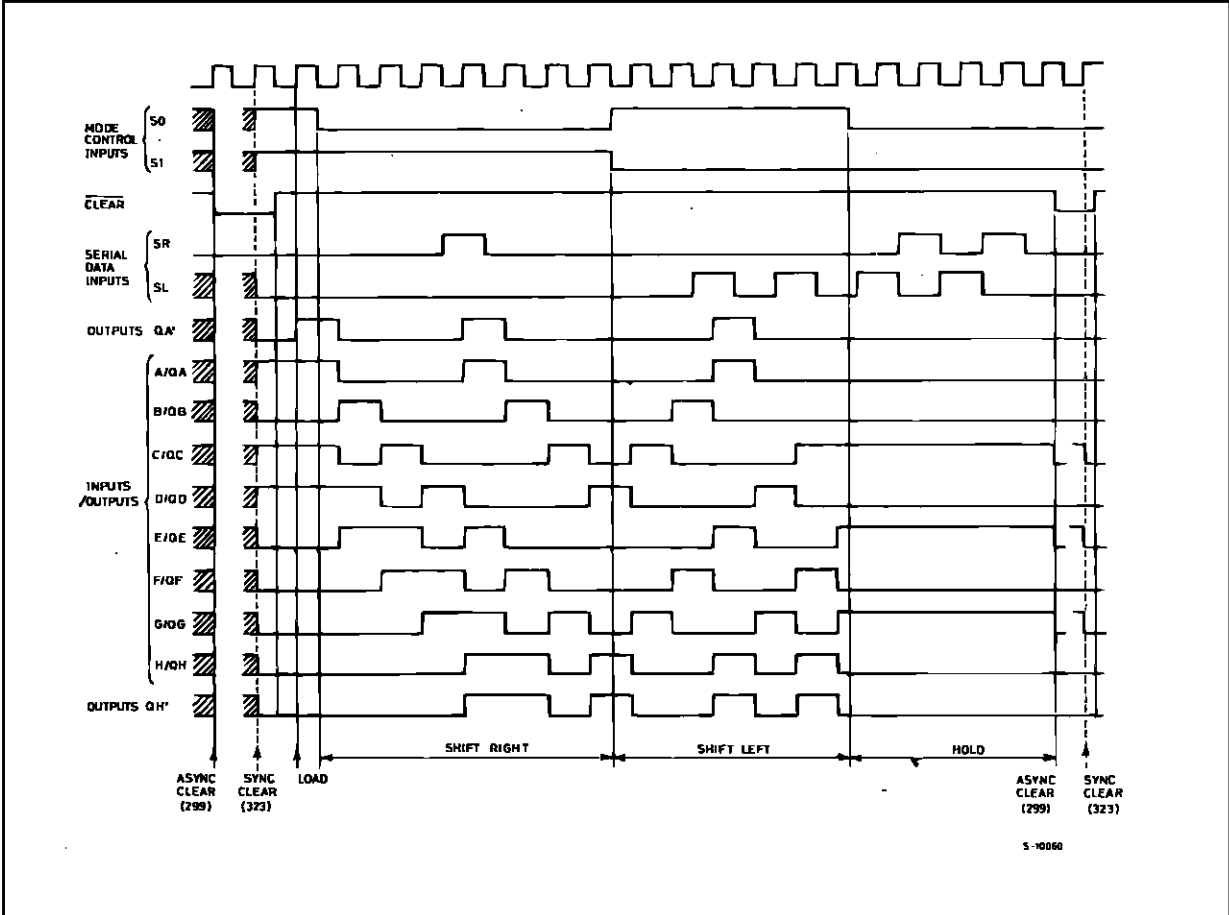

IEC LOGIC SYMBOLS

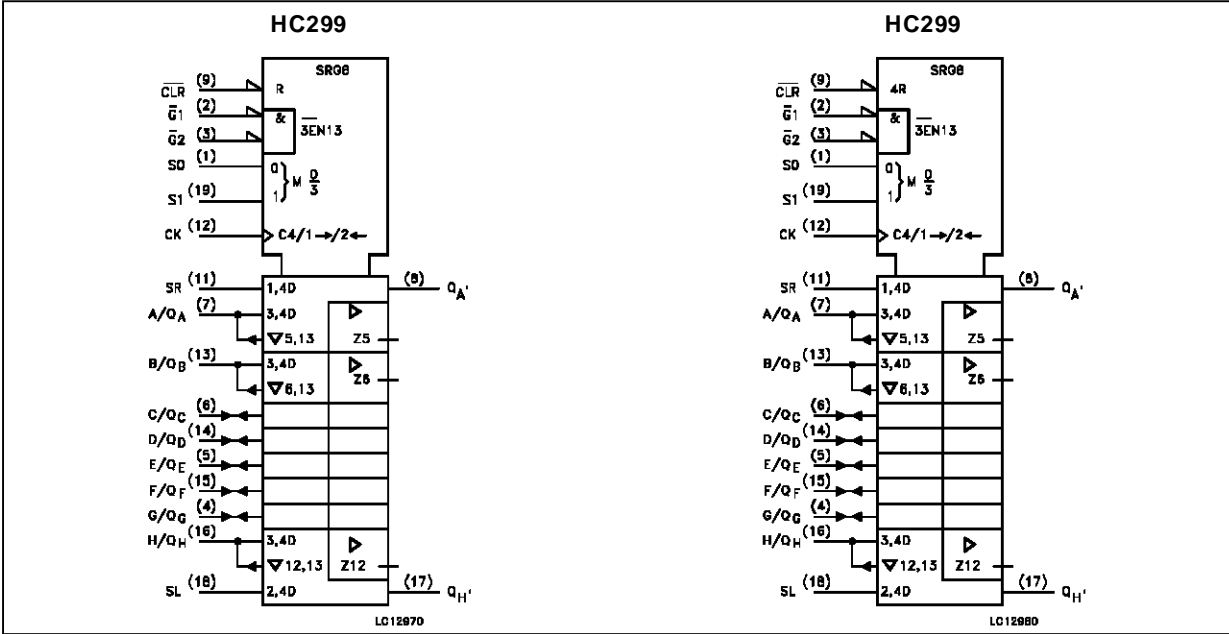

M54/M74HC299/323

PIN DESCRIPTION

| PIN No | SYMBOL | NAME AND FUNCTION |
|----------------------------|--------------------------------|---|
| 1, 19 | S0, S1 | Mode Select Inputs |
| 2, 3 | $\overline{G1}, \overline{G2}$ | 3 State Output Enable Inputs (Active LOW) |
| 7, 13, 6, 14, 5, 15, 4, 16 | A/QA to H/QH | Parallel Data Inputs or 3 State Parallel Outputs (Bus Driver) |
| 8, 17 | QA' to QH' | Serial Outputs (Standard Output) |
| 9 | \overline{CLEAR} | Asynchronous Master Reset Input (Active LOW) |
| 11 | SR | Serial Data Shift Right Input |
| 12 | CLOCK | Clock Input (LOW to HIGH, Edge-triggered) |
| 18 | SL | Serial Data Shift Left Input |
| 10 | GND | Ground (0V) |
| 20 | V _{CC} | Positive Supply Voltage |

ABSOLUTE MAXIMUM RATINGS

| Symbol | Parameter | Value | Unit |
|-------------------------------------|---|-------------------------------|------|
| V _{CC} | Supply Voltage | -0.5 to +7 | V |
| V _I | DC Input Voltage | -0.5 to V _{CC} + 0.5 | V |
| V _O | DC Output Voltage | -0.5 to V _{CC} + 0.5 | V |
| I _{IK} | DC Input Diode Current | ± 20 | mA |
| I _{OK} | DC Output Diode Current | ± 20 | mA |
| I _o | DC Output Source Sink Current Per Output Pin (QA -QH) | ± 35 | mA |
| I _o | DC Output Source Sink Current Per Output Pin (QA' -QH') | ±235 | mA |
| I _{CC} or I _{GND} | DC V _{CC} or Ground Current | ± 70 | mA |
| P _D | Power Dissipation | 500 (*) | mW |
| T _{stg} | Storage Temperature | -65 to +150 | °C |
| T _L | Lead Temperature (10 sec) | 300 | °C |

Absolute Maximum Ratings are those values beyond which damage to the device may occur. Functional operation under these condition is not implied.

(*) 500 mW: ± 65 °C derate to 300 mW by 10mW/°C: 65 °C to 85 °C

RECOMMENDED OPERATING CONDITIONS

| Symbol | Parameter | Value | Unit | |
|---------------------------------|---|---|-----------------------------------|----|
| V _{CC} | Supply Voltage | 2 to 6 | V | |
| V _I | Input Voltage | 0 to V _{CC} | V | |
| V _O | Output Voltage | 0 to V _{CC} | V | |
| T _{op} | Operating Temperature: M54HC Series M74HC Series | -55 to +125 -40 to +85 | °C °C | |
| t _r , t _f | Input Rise and Fall Time | V _{CC} = 2 V V _{CC} = 4.5 V V _{CC} = 6 V | 0 to 1000 0 to 500 0 to 400 | ns |

DC SPECIFICATIONS

| Symbol | Parameter | Test Conditions | | Value | | | | | | Unit | | |
|-----------------|----------------------------------|------------------------|--|--|--------------------------|------|----------------------|------|-----------------------|------|------|------|
| | | V _{CC} (V) | | T _A = 25 °C 54HC and 74HC | | | -40 to 85 °C 74HC | | -55 to 125 °C 54HC | | | |
| | | | | Min. | Typ. | Max. | Min. | Max. | Min. | | Max. | |
| V _{IH} | High Level Input Voltage | 2.0 | | 1.5 | | | 1.5 | | 1.5 | | V | |
| | | 4.5 | | 3.15 | | | 3.15 | | 3.15 | | | |
| | | 6.0 | | 4.2 | | | 4.2 | | 4.2 | | | |
| V _{IL} | Low Level Input Voltage | 2.0 | | | | 0.5 | | 0.5 | | 0.5 | V | |
| | | 4.5 | | | | 1.35 | | 1.35 | | 1.35 | | |
| | | 6.0 | | | | 1.8 | | 1.8 | | 1.8 | | |
| V _{OH} | High Level Output Voltage | 2.0 | V _I = V _{IH} or V _{IL} | I _O = -20 μA | 1.9 | 2.0 | | 1.9 | | 1.9 | V | |
| | | 4.5 | | | 4.4 | 4.5 | | 4.4 | | 4.4 | | |
| | | 6.0 | | | 5.9 | 6.0 | | 5.9 | | 5.9 | | |
| | QA TO QH | 4.5 | | I _O = -6.0 mA | 4.18 | 4.31 | | 4.13 | | 4.10 | | |
| | | 6.0 | | I _O = -7.8 mA | 5.68 | 5.8 | | 5.63 | | 5.60 | | |
| | | QA' TO QH' | | 4.5 | I _O = -4.0 mA | 4.18 | 4.31 | | 4.13 | | | 4.10 |
| 6.0 | I _O = -5.2 mA | | 5.68 | 5.8 | | 5.63 | | 5.60 | | | | |
| V _{OL} | Low Level Output Voltage | | 2.0 | V _I = V _{IH} or V _{IL} | I _O = 20 μA | | 0.0 | 0.1 | | 0.1 | | 0.1 |
| | | 4.5 | | | | 0.0 | 0.1 | | 0.1 | | 0.1 | |
| | | 6.0 | | | | 0.0 | 0.1 | | 0.1 | | 0.1 | |
| | QA TO QH | 4.5 | I _O = 6.0 mA | | | 0.17 | 0.26 | | 0.33 | | 0.40 | |
| | | 6.0 | I _O = 7.8 mA | | | 0.18 | 0.26 | | 0.33 | | 0.40 | |
| | | QA' TO QH' | 4.5 | | I _O = 4.0 mA | | 0.17 | 0.26 | | 0.33 | | 0.40 |
| 6.0 | I _O = 5.2 mA | | | 0.18 | 0.26 | | 0.33 | | 0.40 | | | |
| I _I | Input Leakage Current | | 6.0 | V _I = V _{CC} or GND | | | ±0.1 | | ±1 | | ±1 | μA |
| I _{OZ} | 3 State Output Off-state Current | 6.0 | V _I = V _{IH} or V _{IL} V _O = V _{CC} or GND | | | ±0.5 | | ±5 | | ±10 | μA | |
| I _{CC} | Quiescent Supply Current | 6.0 | V _I = V _{CC} or GND | | | 4 | | 40 | | 80 | μA | |

AC ELECTRICAL CHARACTERISTICS (C_L = 50 pF, Input t_r = t_f = 6 ns)

| Symbol | Parameter | Test Conditions | | Value | | | | | | Unit | | |
|--------------------------------------|---|------------------------|------------------------|---|------|------|----------------------|------|-----------------------|------|------|----|
| | | V _{CC} (V) | C _L (pF) | T _A = 25 °C 54HC and 74HC | | | -40 to 85 °C 74HC | | -55 to 125 °C 54HC | | | |
| | | | | Min. | Typ. | Max. | Min. | Max. | Min. | | Max. | |
| t _{TLH} t _{THL} | Output Transition Time (QA, QH) | 2.0 | 50 | | 25 | 60 | | 75 | | 90 | ns | |
| | | 4.5 | | | 7 | 12 | | 15 | | 18 | | |
| | | 6.0 | | | 6 | 10 | | 13 | | 15 | | |
| t _{TLH} t _{THL} | Output Transition Time (QA', QH') | 2.0 | 50 | | 30 | 75 | | 95 | | 110 | ns | |
| | | 4.5 | | | 8 | 15 | | 19 | | 22 | | |
| | | 6.0 | | | 7 | 13 | | 16 | | 19 | | |
| t _{PLH} t _{PHL} | Propagation Delay Time (CK - QA', QH') | 2.0 | 50 | | 85 | 170 | | 215 | | 255 | ns | |
| | | 4.5 | | | 23 | 34 | | 43 | | 51 | | |
| | | 6.0 | | | 18 | 29 | | 37 | | 43 | | |
| t _{PHL} | Propagation Delay Time (CLR - QA', QH') | 2.0 | 50 | for HC299 | | 85 | 175 | | 220 | | 265 | ns |
| | | 4.5 | | | | 24 | 35 | | 44 | | 53 | |
| | | 6.0 | | | | 18 | 30 | | 37 | | 45 | |

M54/M74HC299/323

AC ELECTRICAL CHARACTERISTICS ($C_L = 50$ pF, Input $t_r = t_f = 6$ ns)

| Symbol | Parameter | Test Conditions | | | Value | | | | | | Unit | |
|--|--|------------------------|------------------------|-----------------------|---|------|------|----------------------|------|-----------------------|------|------|
| | | V _{CC} (V) | C _L (pF) | | T _A = 25 °C 54HC and 74HC | | | -40 to 85 °C 74HC | | -55 to 125 °C 54HC | | |
| | | | | | Min. | Typ. | Max. | Min. | Max. | Min. | | Max. |
| t _{PLH} t _{PHL} | Propagation Delay Time (CK - QA, QH) | 2.0 | 50 | | | 80 | 160 | | 200 | | 240 | ns |
| | | 4.5 | | | | 21 | 32 | | 40 | | 48 | |
| | | 6.0 | | | | 17 | 27 | | 34 | | 41 | |
| | | 2.0 | 150 | | | 100 | 200 | | 250 | | 300 | ns |
| | | 4.5 | | | | 26 | 40 | | 50 | | 60 | |
| | | 6.0 | | | | 21 | 34 | | 43 | | 51 | |
| t _{PHL} | Propagation Delay Time (CLR - QA, QH) | 2.0 | 50 | for HC323 | | 85 | 190 | | 240 | | 285 | ns |
| | | 4.5 | | | | 24 | 38 | | 48 | | 57 | |
| | | 6.0 | | | | 18 | 32 | | 41 | | 48 | |
| | | 2.0 | 150 | for HC323 | | 105 | 230 | | 290 | | 345 | ns |
| | | 4.5 | | | | 29 | 46 | | 58 | | 69 | |
| | | 6.0 | | | | 22 | 39 | | 49 | | 59 | |
| t _{PZL} t _{PZH} | 3 State Output Enable Time | 2.0 | 50 | R _L = 1 KΩ | | 60 | 130 | | 165 | | 195 | ns |
| | | 4.5 | | | | 17 | 26 | | 33 | | 39 | |
| | | 6.0 | | | | 13 | 22 | | 28 | | 33 | |
| | | 2.0 | 150 | R _L = 1 KΩ | | 78 | 170 | | 15 | | 255 | ns |
| | | 4.5 | | | | 23 | 34 | | 43 | | 51 | |
| | | 6.0 | | | | 17 | 29 | | 37 | | 43 | |
| t _{PLZ} t _{PHZ} | 3 State Output Disable Time | 2.0 | 50 | R _L = 1 KΩ | | 54 | 150 | | 190 | | 225 | ns |
| | | 4.5 | | | | 19 | 30 | | 38 | | 45 | |
| | | 6.0 | | | | 16 | 26 | | 32 | | 38 | |
| f _{MAX} | Maximum Clock Frequency | 2.0 | 50 | | 6 | 12 | | 4.8 | | 4 | | ns |
| | | 4.5 | | | 30 | 58 | | 24 | | 20 | | |
| | | 6.0 | | | 35 | 80 | | 28 | | 24 | | |
| t _{W(L)} t _{W(H)} | Minimum Pulse Width (CLOCK) | 2.0 | 50 | | | | 75 | | 95 | | 110 | ns |
| | | 4.5 | | | | | 15 | | 19 | | 22 | |
| | | 6.0 | | | | | 13 | | 16 | | 19 | |
| t _{W(L)} | Minimum Pulse Width (CLEAR) | 2.0 | 50 | for HC299 | | | 75 | | 95 | | 110 | ns |
| | | 4.5 | | | | | 15 | | 19 | | 22 | |
| | | 6.0 | | | | | 13 | | 16 | | 19 | |
| t _s | Minimum Set-up Time (S0, S1) (SL, SR, A H) (CLEAR for 323) | 2.0 | 50 | | | | 100 | | 125 | | 150 | ns |
| | | 4.5 | | | | | 20 | | 25 | | 30 | |
| | | 6.0 | | | | | 17 | | 21 | | 26 | |
| t _h | Minimum Hold Time (S0, S1) (SL, SR, A H) (CLEAR for 323) | 2.0 | 50 | | | | 0 | | 0 | | 0 | ns |
| | | 4.5 | | | | | 0 | | 0 | | 0 | |
| | | 6.0 | | | | | 0 | | 0 | | 0 | |
| t _{REM} | Minimum Removal Time (CLEAR) | 2.0 | 50 | for HC299 | | | 50 | | 65 | | 75 | ns |
| | | 4.5 | | | | | 10 | | 13 | | 15 | |
| | | 6.0 | | | | | 9 | | 11 | | 13 | |
| C _{IN} | Input Capacitance | | | | | 5 | 10 | | 10 | | 10 | pF |
| C _{PD} (*) | Power Dissipation Capacitance | | | | | 170 | | | | | | pF |

(*) C_{PD} is defined as the value of the IC's internal equivalent capacitance which is calculated from the operating current consumption without load. (Refer to Test Circuit). Average operating current can be obtained by the following equation. $I_{CC(opr)} = C_{PD} \cdot V_{CC} \cdot f_{IN} + I_{CC}$

SWITCHING CHARACTERISTICS TEST WAVEFORM

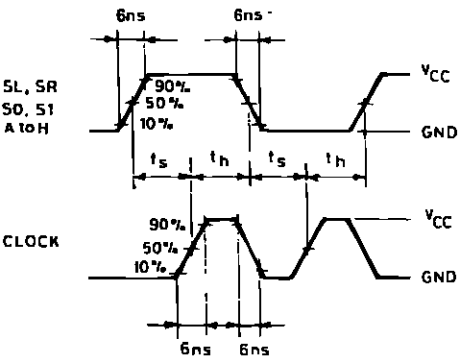
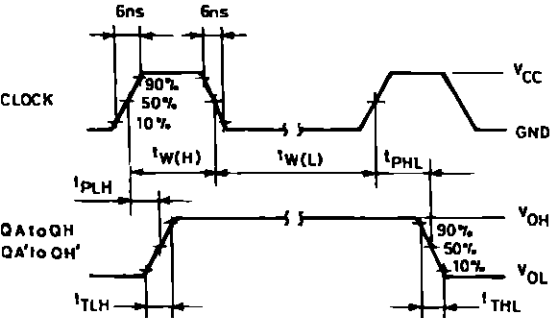

S-10062

HC299

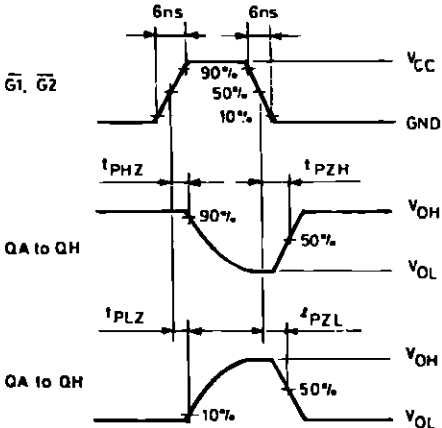
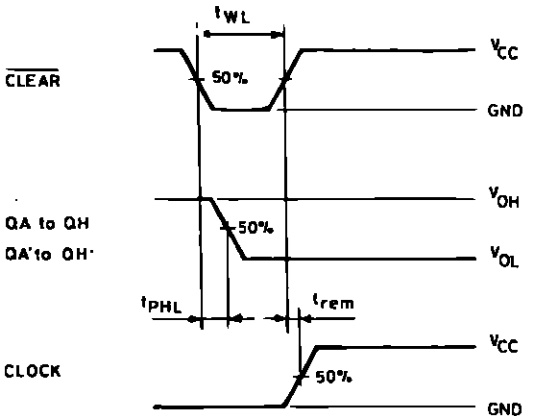

HC323

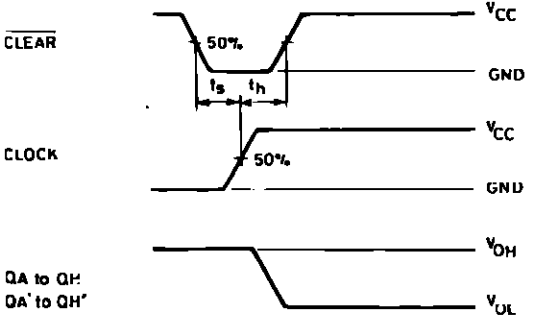

S-10062

M54/M74HC299/323

TEST CIRCUIT I_{CC} (Opr.)

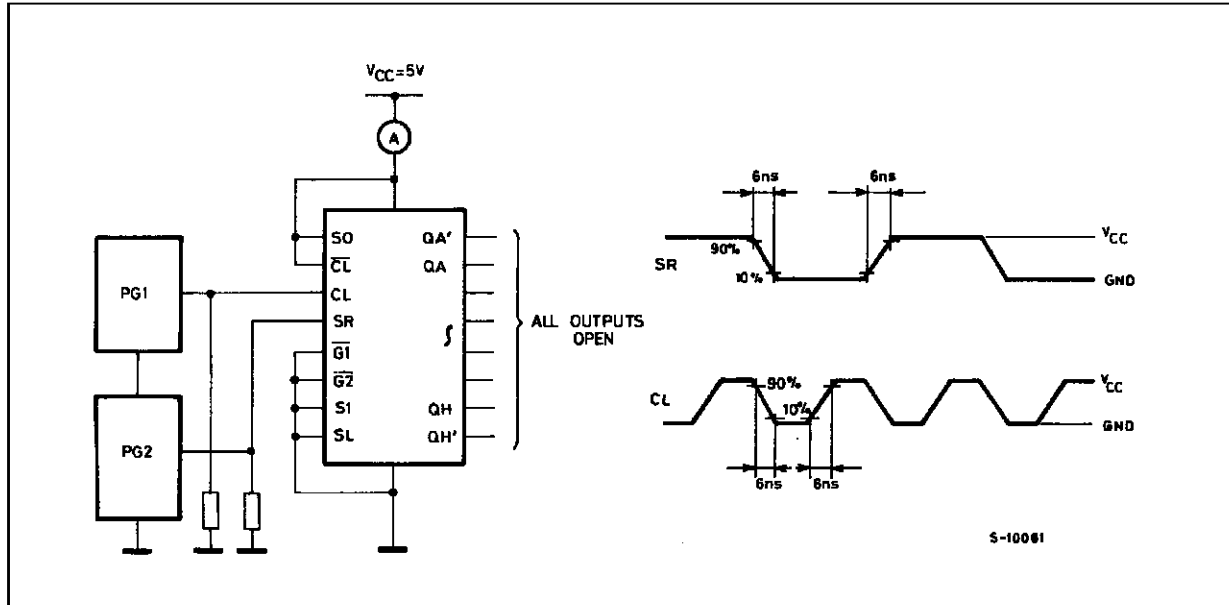

Plastic DIP20 (0.25) MECHANICAL DATA

| DIM. | mm | | | inch | | |
|------|-------|-------|------|-------|-------|-------|
| | MIN. | TYP. | MAX. | MIN. | TYP. | MAX. |
| a1 | 0.254 | | | 0.010 | | |
| B | 1.39 | | 1.65 | 0.055 | | 0.065 |
| b | | 0.45 | | | 0.018 | |
| b1 | | 0.25 | | | 0.010 | |
| D | | | 25.4 | | | 1.000 |
| E | | 8.5 | | | 0.335 | |
| e | | 2.54 | | | 0.100 | |
| e3 | | 22.86 | | | 0.900 | |
| F | | | 7.1 | | | 0.280 |
| l | | | 3.93 | | | 0.155 |
| L | | 3.3 | | | 0.130 | |
| Z | | | 1.34 | | | 0.053 |

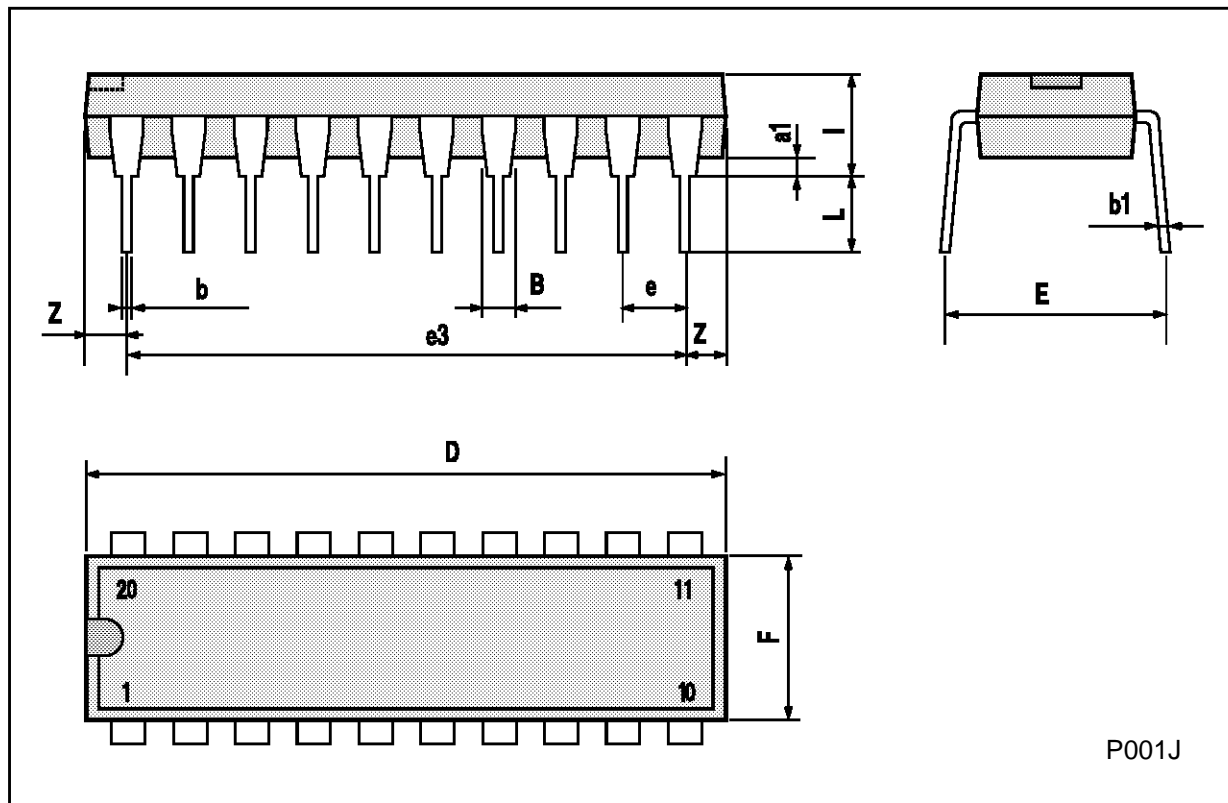

P001J

Ceramic DIP20 MECHANICAL DATA

| DIM. | mm | | | inch | | |
|------|-----------------------|-------|------|-------|-------|-------|
| | MIN. | TYP. | MAX. | MIN. | TYP. | MAX. |
| A | | | 25 | | | 0.984 |
| B | | | 7.8 | | | 0.307 |
| D | | 3.3 | | | 0.130 | |
| E | 0.5 | | 1.78 | 0.020 | | 0.070 |
| e3 | | 22.86 | | | 0.900 | |
| F | 2.29 | | 2.79 | 0.090 | | 0.110 |
| G | 0.4 | | 0.55 | 0.016 | | 0.022 |
| I | 1.27 | | 1.52 | 0.050 | | 0.060 |
| L | 0.22 | | 0.31 | 0.009 | | 0.012 |
| M | 0.51 | | 1.27 | 0.020 | | 0.050 |
| N1 | 4° (min.), 15° (max.) | | | | | |
| P | 7.9 | | 8.13 | 0.311 | | 0.320 |
| Q | | | 5.71 | | | 0.225 |

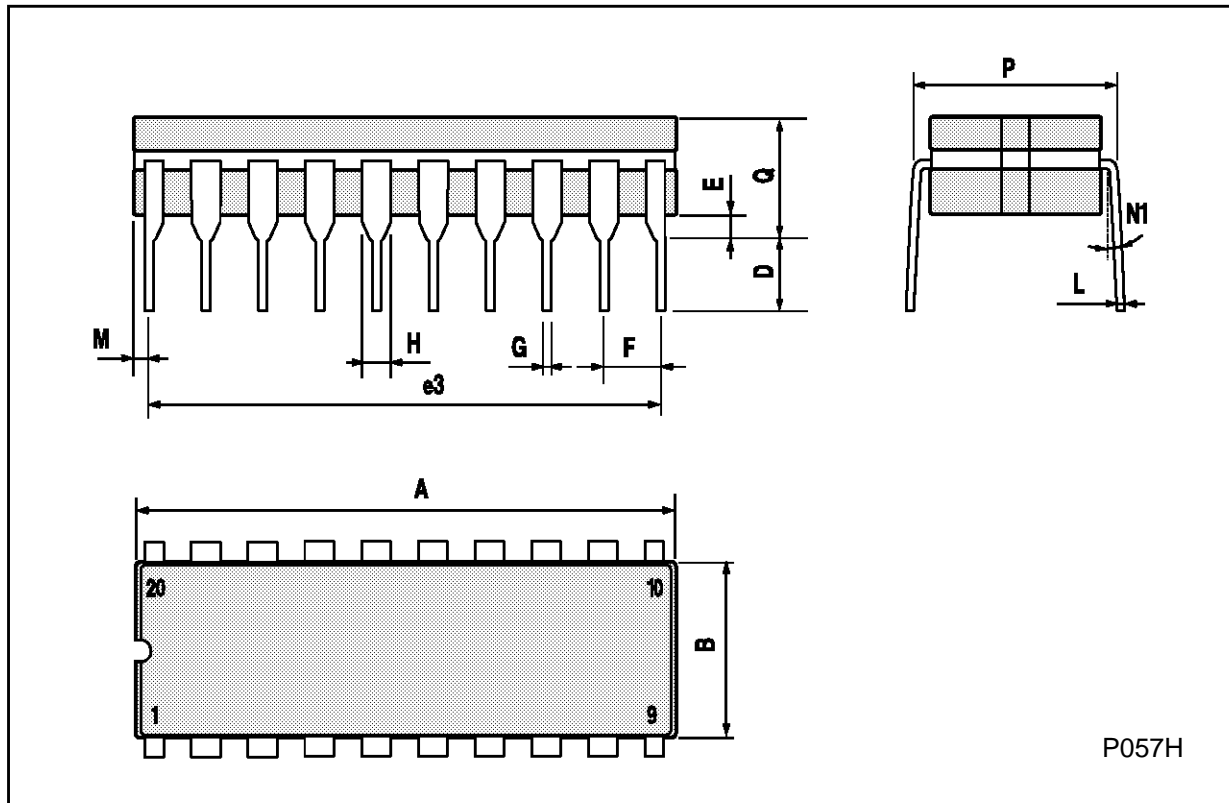

P057H

SO20 MECHANICAL DATA

| DIM. | mm | | | inch | | |
|------|------------|-------|-------|-------|-------|-------|
| | MIN. | TYP. | MAX. | MIN. | TYP. | MAX. |
| A | | | 2.65 | | | 0.104 |
| a1 | 0.10 | | 0.20 | 0.004 | | 0.007 |
| a2 | | | 2.45 | | | 0.096 |
| b | 0.35 | | 0.49 | 0.013 | | 0.019 |
| b1 | 0.23 | | 0.32 | 0.009 | | 0.012 |
| C | | 0.50 | | | 0.020 | |
| c1 | 45° (typ.) | | | | | |
| D | 12.60 | | 13.00 | 0.496 | | 0.512 |
| E | 10.00 | | 10.65 | 0.393 | | 0.419 |
| e | | 1.27 | | | 0.050 | |
| e3 | | 11.43 | | | 0.450 | |
| F | 7.40 | | 7.60 | 0.291 | | 0.299 |
| L | 0.50 | | 1.27 | 0.19 | | 0.050 |
| M | | | 0.75 | | | 0.029 |
| S | 8° (max.) | | | | | |

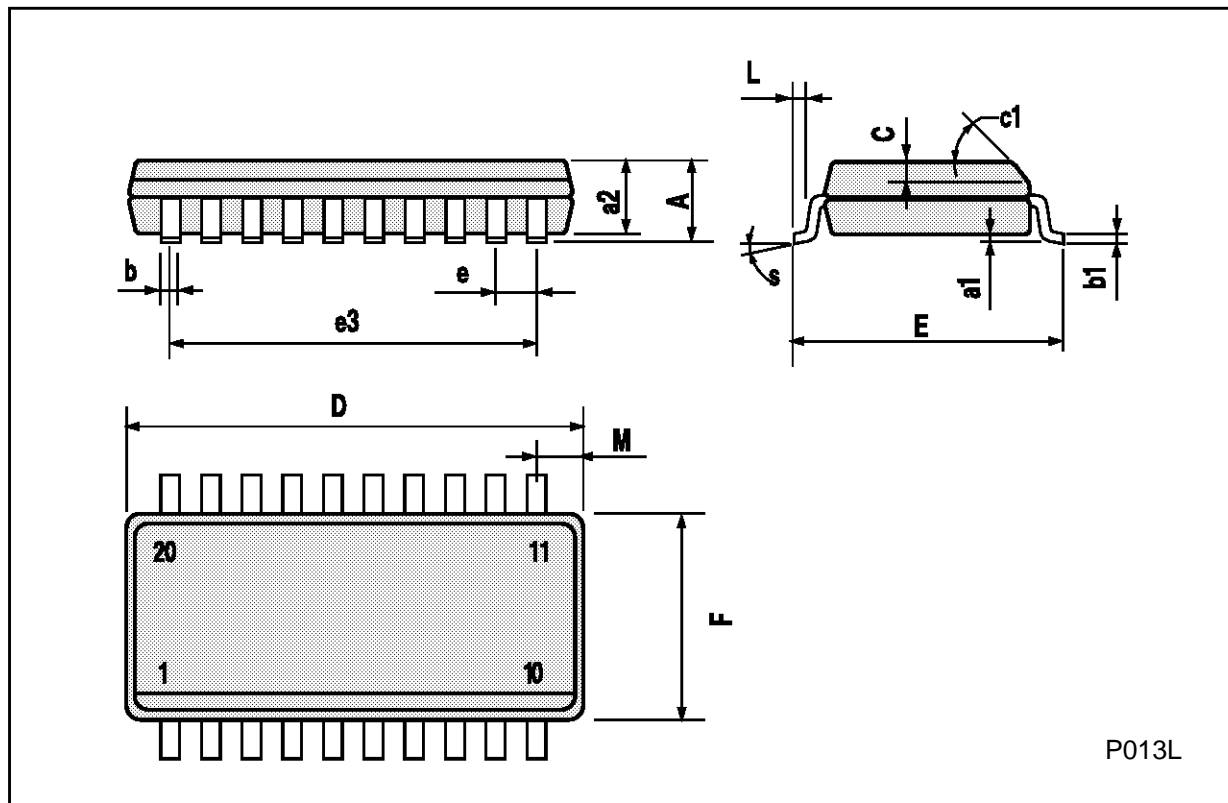

PLCC20 MECHANICAL DATA

| DIM. | mm | | | inch | | |
|------|------|------|-------|-------|-------|-------|
| | MIN. | TYP. | MAX. | MIN. | TYP. | MAX. |
| A | 9.78 | | 10.03 | 0.385 | | 0.395 |
| B | 8.89 | | 9.04 | 0.350 | | 0.356 |
| D | 4.2 | | 4.57 | 0.165 | | 0.180 |
| d1 | | 2.54 | | | 0.100 | |
| d2 | | 0.56 | | | 0.022 | |
| E | 7.37 | | 8.38 | 0.290 | | 0.330 |
| e | | 1.27 | | | 0.050 | |
| e3 | | 5.08 | | | 0.200 | |
| F | | 0.38 | | | 0.015 | |
| G | | | 0.101 | | | 0.004 |
| M | | 1.27 | | | 0.050 | |
| M1 | | 1.14 | | | 0.045 | |

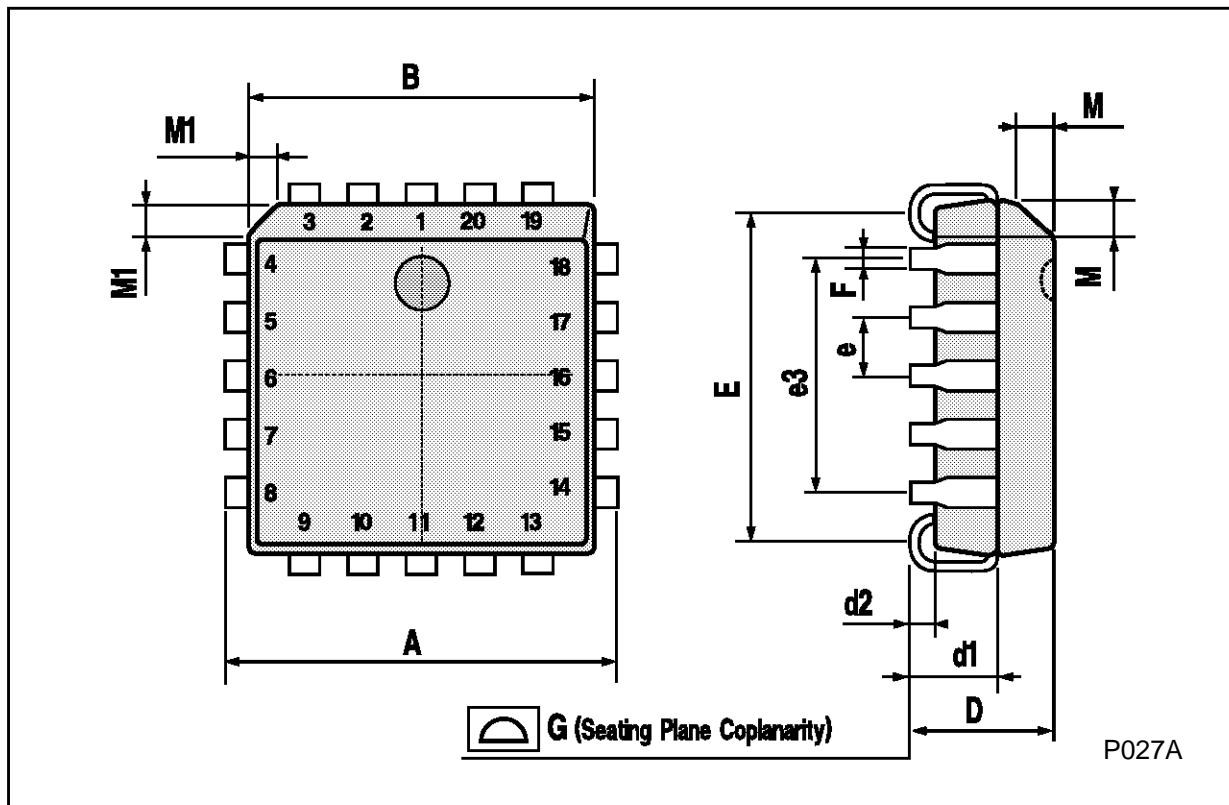

P027A

Information furnished is believed to be accurate and reliable. However, SGS-THOMSON Microelectronics assumes no responsibility for the consequences of use of such information nor for any infringement of patents or other rights of third parties which may result from its use. No license is granted by implication or otherwise under any patent or patent rights of SGS-THOMSON Microelectronics. Specifications mentioned in this publication are subject to change without notice. This publication supersedes and replaces all information previously supplied. SGS-THOMSON Microelectronics products are not authorized for use as critical components in life support devices or systems without express written approval of SGS-THOMSON Microelectronics.

© 1994 SGS-THOMSON Microelectronics - All Rights Reserved

SGS-THOMSON Microelectronics GROUP OF COMPANIES
Australia - Brazil - France - Germany - Hong Kong - Italy - Japan - Korea - Malaysia - Malta - Morocco - The Netherlands -
Singapore - Spain - Sweden - Switzerland - Taiwan - Thailand - United Kingdom - U.S.A