



TC4949

Multifunction Very Low Dropout Voltage Regulator

FEATURES

- Operating DC Supply Voltage Range 5.0V to 28V
- Transient Supply Voltage up to 40V
- Extremely Low Quiescent Current in Standby Mode
- High Precision Standby Output Voltage 5.0V \pm 1%
- Output Current Capability up to 100mA
- Very Low Dropout Voltage less than 0.4V
- Reset Circuit Sensing the Output Voltage
- Programmable Reset Pulse Delay with External Capacitor
- Voltage Sense Comparator
- Thermal Shutdown and Short Circuit Protections

GENERAL DESCRIPTION

The TC4949 is a monolithic integrated 5.0V voltage regulator with a very low dropout and additional functions such as power-on reset and input voltage sense. It is designed for supplying the micro-computer controlled systems especially in automotive applications.

ORDERING INFORMATION

Part Number	Package	Temperature Range
TC4949VPA	8-Pin PDIP (Narrow)	-40 to +125°C
TC4949VOA	8-Pin SOIC (Narrow)	-40 to +125°C

REPRESENTATIVE BLOCK DIAGRAM

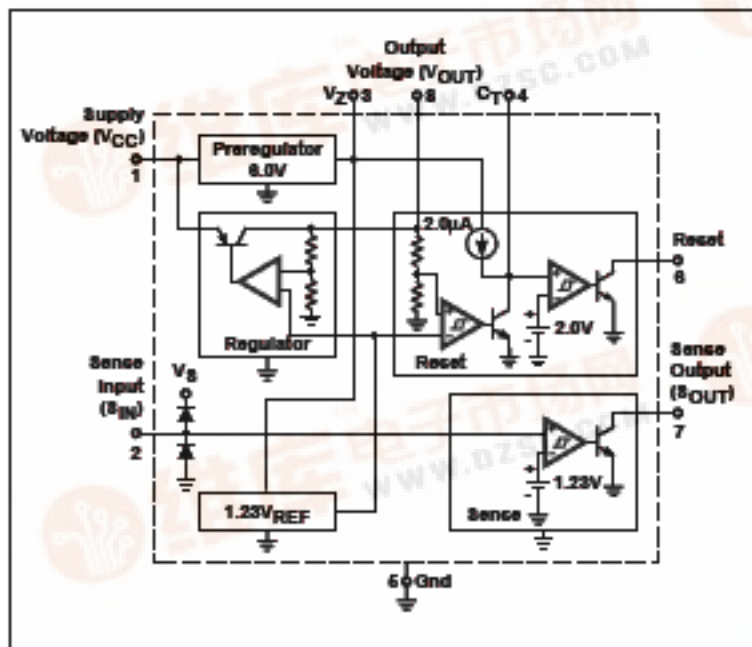

PIN CONFIGURATIONS

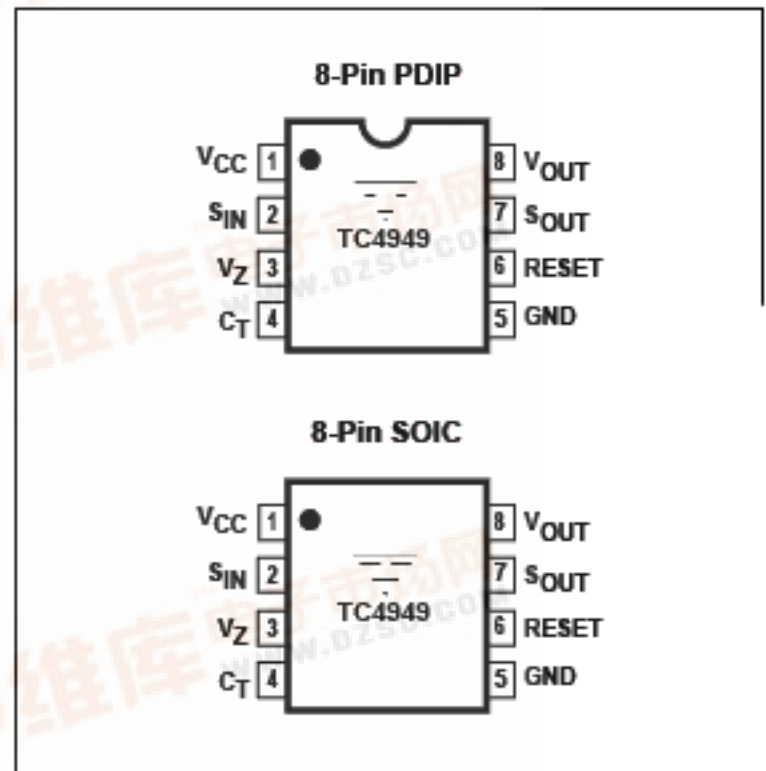

Multifunction Very Low Dropout Voltage Regulator

TC4949

ABSOLUTE MAXIMUM RATINGS*

DC Operating Supply Voltage	$V_{CC} = 28V$
Transient Supply Voltage ($T < 1.0$ s)	$V_{CC\ TR} = 40V$
Output Current	I_{OUT} (Internally Limited)
Output Voltage	$V_{OUT} = 20V$
Sense Input Current	$I_{SI} = \pm 1.0mA$
Sense Input Voltage	$V_{SI} = V_{CC}$
Output Voltages	
Reset Output	$V_{RESET} = 20V$
Sense Output	$V_{SO} = 20V$
Output Currents	
Reset Output	$I_{RESET} = 5.0mA$
Sense Output	$I_{SO} = 5.0mA$
Preregulator Output Voltage	$V_Z = 7.0V$
Preregulator Output Current	$I_Z = 5.0mA$

ESD Protection at any pin

Human Body Model	2000V
Machine Model	400V

Thermal Resistance, Junction-to-Air

P Suffix, DIP-8 Plastic Package, Case 626	$\theta_{JA} = 100^{\circ}C/W$
D Suffix, SO-8 Plastic Package, Case 751	$\theta_{JA} = 200^{\circ}C/W$

Maximum Junction Temperature $T_J = 150^{\circ}C$

Storage Temperature Range $T_{STG} = -65$ to $+150^{\circ}C$

*This is a stress rating only, and functional operation of the device at these or any other conditions beyond those indicated in the operation section of the specifications is not implied. Exposure to absolute maximum ratings conditions for extended periods of time may affect device reliability.

ELECTRICAL CHARACTERISTICS: ($V_{CC} = 14V$, $-40^{\circ}C < T_J < 125^{\circ}C$, unless otherwise specified)

Symbol	Parameter	Test Conditions	Min	Typ	Max	Units
V_{OUT}	Output Voltage	$T_J = 25^{\circ}C$, $I_{OUT} = 1.0mA$ $6.0V < V_{CC} < 28V$, $1.0mA < I_{OUT} < 50mA$ $V_{CC} = 35V$, $t < 1.0$ s, $1.0mA < I_{OUT} < 50mA$	4.95 4.9 4.9	5.0 5.0 5.0	5.05 5.1 5.1	V
V_{DROP}	Dropout Voltage	$I_{OUT} = 10mA$ $I_{OUT} = 50mA$ $I_{OUT} = 100mA$	- - -	0.1 0.2 0.3	0.25 0.40 0.50	V
V_{IO}	Input to Output Voltage Difference in Undervoltage Condition	$V_{CC} = 4.0V$, $I_{OUT} = 35mA$	-	0.2	0.4	V
REG_{LINE}	Line Regulation	$6.0V < V_{CC} < 28V$, $I_{OUT} = 1.0mA$	-	1.0	20	mV
REG_{LOAD}	Load Regulation	$1.0mA < I_{OUT} < 100mA$	-	8.0	30	mV
I_{LIM}	Current Limit	$V_{OUT} = 4.5V$ $V_{OUT} = 0V$	105 -	200 100	400 -	mA
I_{QSE}	Quiescent Current	$I_{OUT} = 0.3mA$, $T_J < 100^{\circ}C$	-	150	260	μA
I_Q		$I_{OUT} = 100mA$	-	-	5.0	mA

RESET

V_{RESETH}	Reset Threshold Voltage		-	$V_{OUT} - 0.5$	-	V
$V_{RESETH,HYS}$	Reset Threshold Hysteresis	@ $T_J = 25^{\circ}C$ @ $T_J = -40$ to $+125^{\circ}C$	50 50	100 -	200 300	mV
T_{RESO}	Reset Pulse Delay	$C_T = 100nF$, $T_R \geq 100\mu s$	55	100	180	ms
T_{RESR}	Reset Reaction Time	$C_T = 100nF$	-	5.0	30	μs
V_{RESL}	Reset Output Low Voltage	$R_{RESET} = 10k\Omega$ to V_{OUT} , $V_{CC} \geq 3.0V$	-	-	0.4	V
I_{RESH}	Reset Output High Leakage Current	$V_{RESET} = 5.0V$	-	-	1.0	μA
V_{CTTH}	Delay Comparator Threshold		-	2.0	-	V
$V_{CTTH,HYS}$	Delay Comparator Threshold Hysteresis		-	100	-	mV

Multifunction Very Low Dropout Voltage Regulator

TC4949

ELECTRICAL CHARACTERISTICS: ($V_{CC} = 14V$, $-40^{\circ}C < T_J < 125^{\circ}C$, unless otherwise specified)

Symbol	Parameter	Test Conditions	Min	Typ	Max	Units
SENSE						
V_{SOTL}	Sense Low Threshold	V_{S1} Decreasing = 1.5V to 1.0V)	1.16	1.23	1.35	V
$V_{SOTL,HYS}$	Sense Threshold Hysteresis		20	100	200	mV
V_{SOL}	Sense Output Low Voltage	$V_{S1} \leq 1.16V$, $V_{CC} \geq 3.0V$, $R_{S0} = 10k\Omega$ to V_{OUT}	-	-	0.4	V
I_{SOL}	Sense Output Leakage	$V_{S0} = 5.0V$, $V_{S1} \geq 1.5V$	-	-	1.0	μA
I_{S1}	Sense Input Current		1.0	0.1	1.0	μA
PREREGULATOR						
V_Z	Preregulator Output Voltage	$I_Z = 10\mu A$	-	6.3	-	V

PIN DESCRIPTION

Pin	Symbol	Description
1	V_{CC}	Supply Voltage
2	S_{IN}	Input of Sense Comparator
3	V_Z	Output of Preregulator
4	C_T	Reset Delay Capacitor
5	GND	Ground
6	RESET	Output of Reset Comparator
7	S_{OUT}	Output of Sense Comparator
8	V_{OUT}	Main Regulator Output

TYPICAL CHARACTERISTICS

Figure 1. Output Voltage versus Junction Temperature

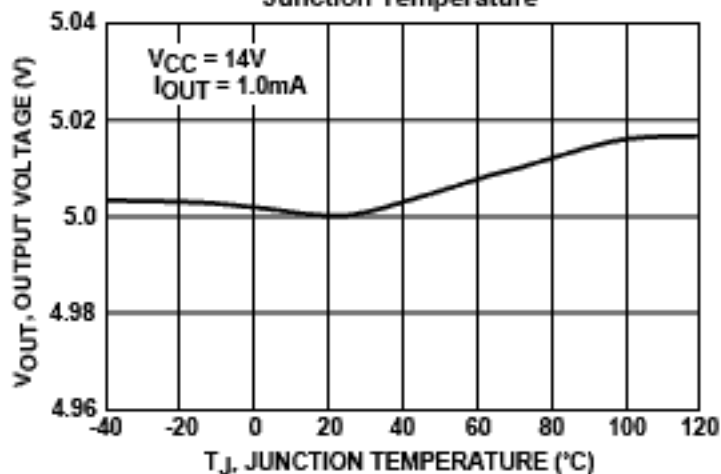
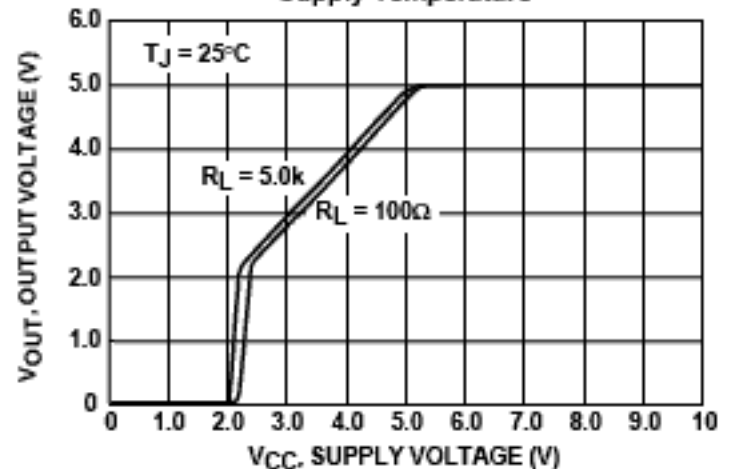

Figure 2. Output Voltage versus Supply Voltage



Multifunction Very Low Dropout Voltage Regulator

TC4949

TYPICAL CHARACTERISTICS

Figure 3. Dropout Voltage versus Output Current

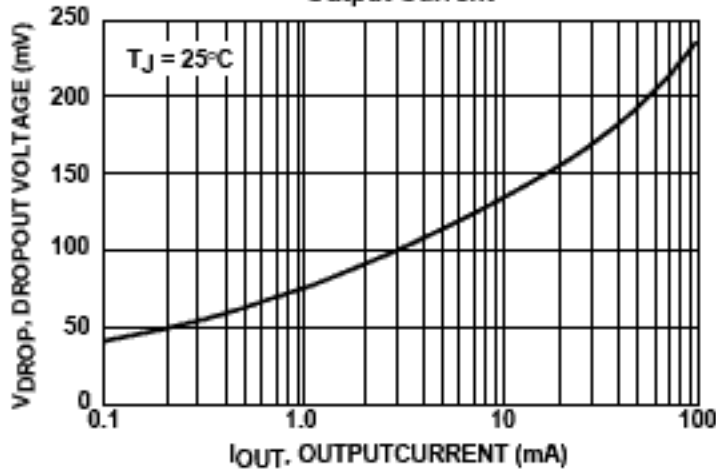

Figure 4. Dropout Voltage versus Junction Temperature

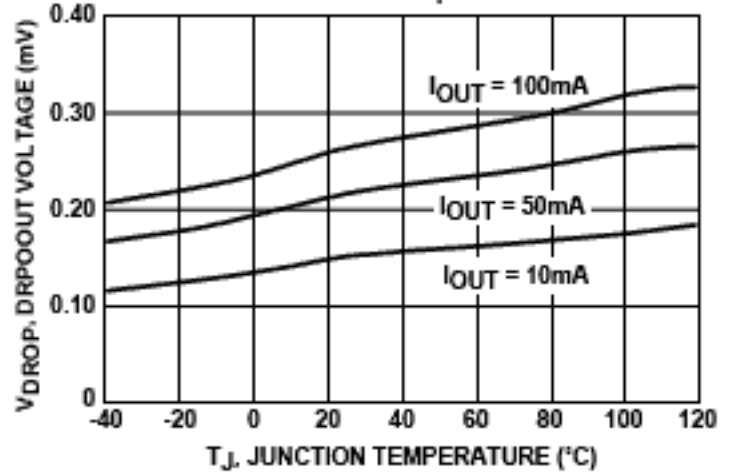

Figure 5. Quiescent Current versus Output Current

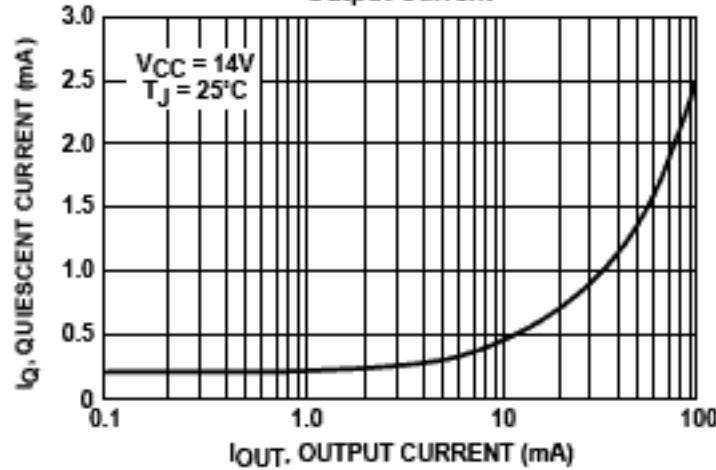

Figure 6. Quiescent Current versus Supply Voltage

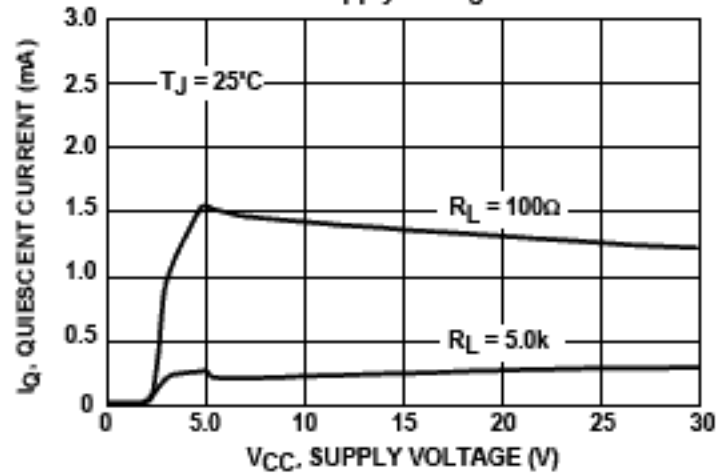

Figure 7. Reset Output versus Regulator Output Voltage

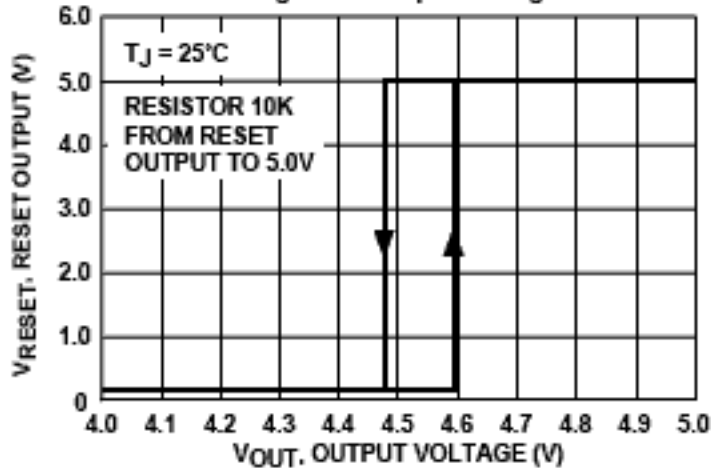
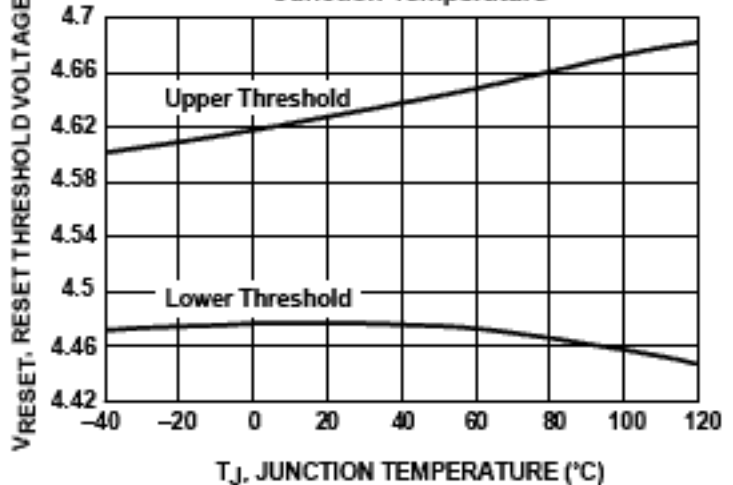

Figure 8. Reset Thresholds versus Junction Temperature



Multifunction Very Low Dropout Voltage Regulator

TC4949

TYPICAL CHARACTERISTICS

Figure 9. Sense Output versus Sense Input Voltage

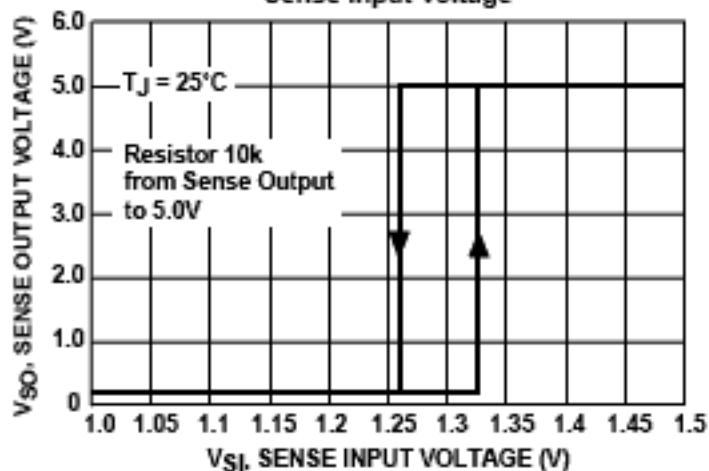
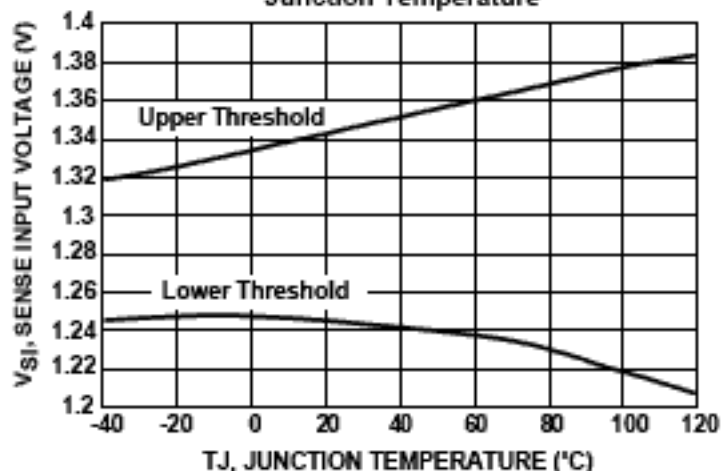

Figure 10. Sense Thresholds versus Junction Temperature



APPLICATION INFORMATION

Supply Voltage Transient

High supply voltage transients can cause a reset output signal perturbation. For supply voltages greater than 8.0V the circuit shows a high immunity of the reset output against supply transients of more than 100V/ μsec . For supply volt-

ages less than 8.0V supply transients of more than 0.4V/ μsec can cause a reset signal perturbation. To improve the transient behavior for supply voltages less than 8.0V a capacitor at Pin 3 can be used. A capacitor at Pin 3 ($C_3 \leq 1.0\mu\text{F}$) reduces also the output noise.

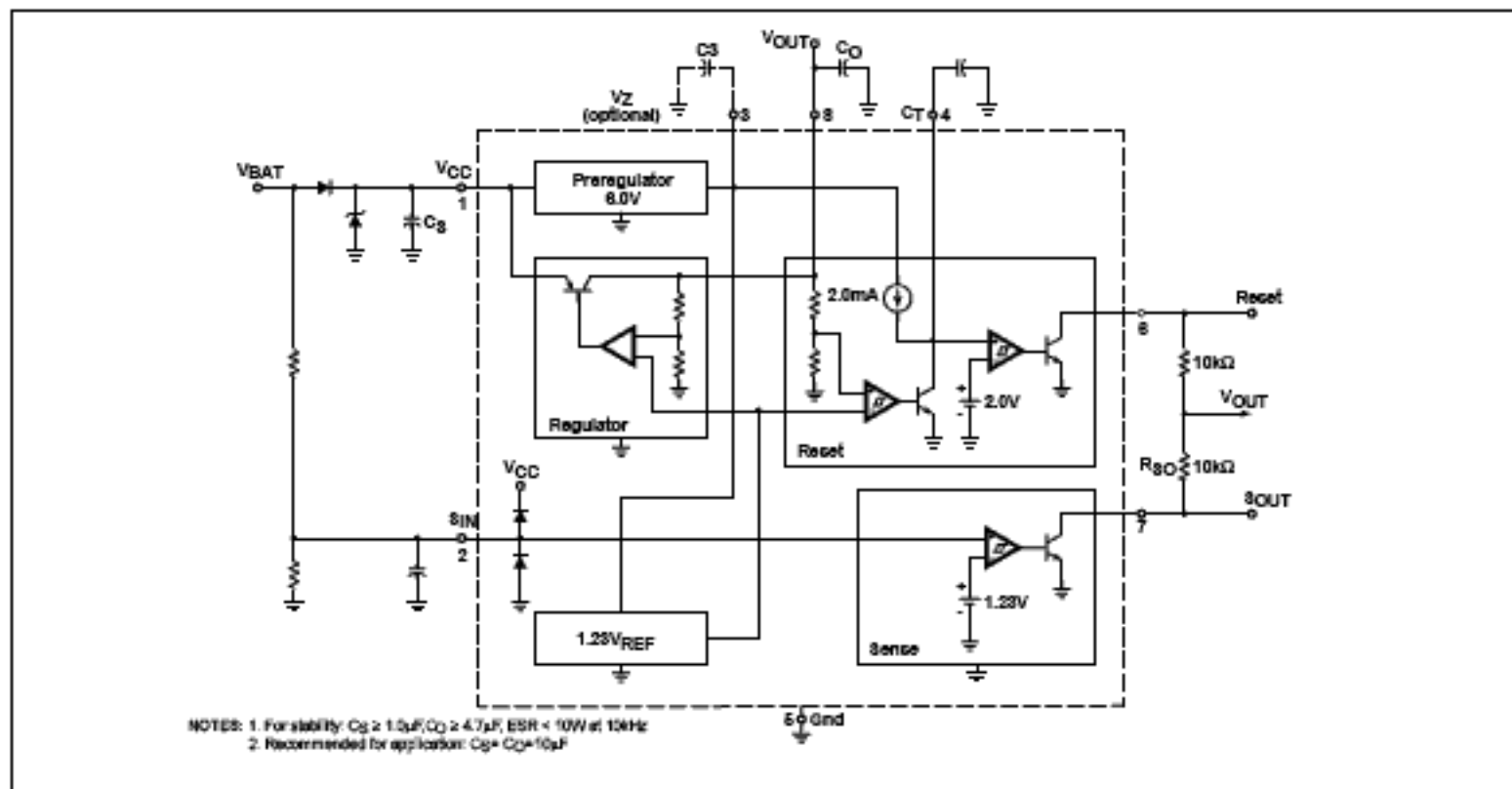

Figure 11. Application Schematic

Multifunction Very Low Dropout Voltage Regulator

TC4949

OPERATING DESCRIPTION

The TC4949 is a monolithic integrated low dropout voltage regulator. Several outstanding features and auxiliary functions are implemented to meet the requirements of supplying microprocessor systems in automotive applications. Nevertheless, it is suitable also in other applications where the present functions are required. The modular approach of this device allows the use of other features and functions independently when required.

Voltage Regulator

The voltage regulator uses an isolated Collector Vertical PNP transistor as a regulating element. With this structure, very low dropout voltage at currents up to 100mA is obtained. The dropout operation of the standby regulator is maintained down to 3.0V input supply voltage. The output voltage is regulated up to the transient input supply voltage of 35V. With this feature no functional interruption due to overvoltage pulses is generated.

The typical curve showing the standby output voltage as a function of the input supply voltage is shown in Figure 13.

The current consumption of the device (quiescent current) is less than 200 μ A.

To reduce the quiescent current peak in the undervoltage region and to improve the transient response in this region, the dropout voltage is controlled. The quiescent current as a function of the supply input voltage is shown in Figure 14.

Short Circuit Protection:

The maximum output current is internally limited. In case of short circuit, the output current is foldback current limited as described in Figure 12.

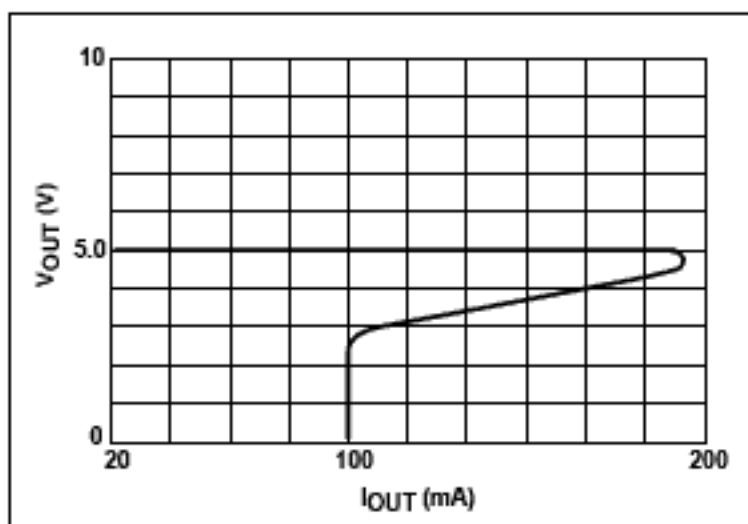

Figure 12. Foldback Characteristic of V_{OUT}

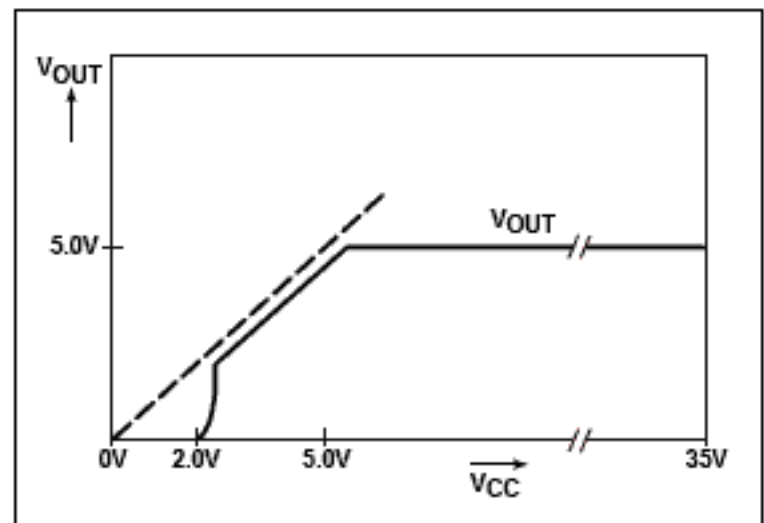

Figure 13. Output Voltage versus Supply Voltage

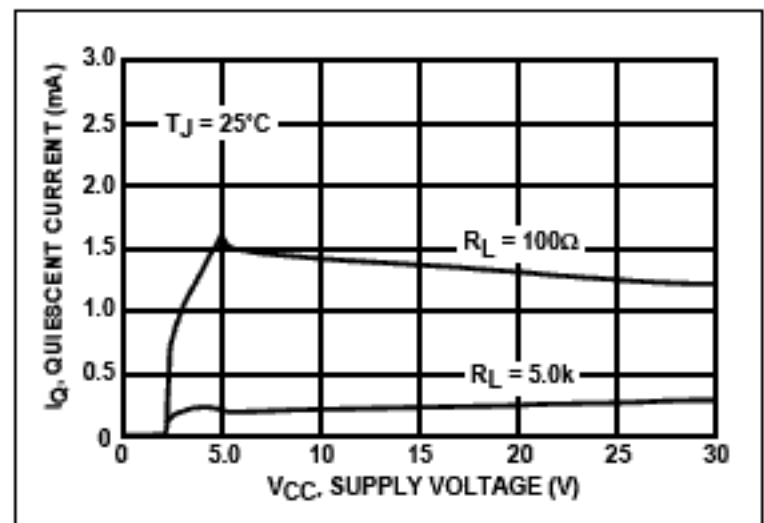

Figure 14. Quiescent Current versus Supply Voltage

Preregulator

To improve the transient immunity a preregulator stabilizes the internal supply voltage to 6.0V. This internal voltage is present at Pin 3 (V_Z). This voltage should not be used as an output because the output capability is very small ($\leq 100\mu$ A).

This output may be used as an option when better transient behavior for supply voltages less than 8.0V is required. In this case a capacitor (100nF – 1.0 μ F) must be connected between Pin 3 and Gnd. If this feature is not used Pin 3 must be left open.

Reset Circuit

The block circuit diagram of the reset circuit is shown in Figure 15.

The reset circuit supervises the output voltage. The reset threshold of 4.5V is defined with the internal reference voltage and standby output divider.

The reset pulse delay time T_{RD} , is defined with the charge time of an external capacitor C_T :

$$T_{RD} = \frac{C_T \times 2.0V}{2.0\mu A}$$

The reaction time of the reset circuit originates from the discharge time limitation of the reset capacitor C_T and is proportional to the value of C_T . The reaction time of the reset circuit increases the noise immunity.

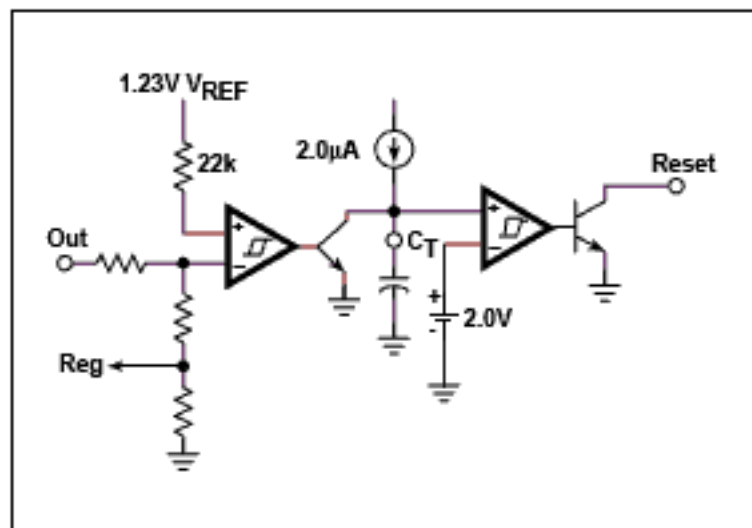

Figure 15. Reset Circuit

Standby output voltage drops below the reset threshold only a bit longer than the reaction time results in a shorter reset delay time.

The nominal reset delay time will be generated for standby output voltage drops longer than approximately 50μsec. The typical reset output waveforms are shown in Figure 16.

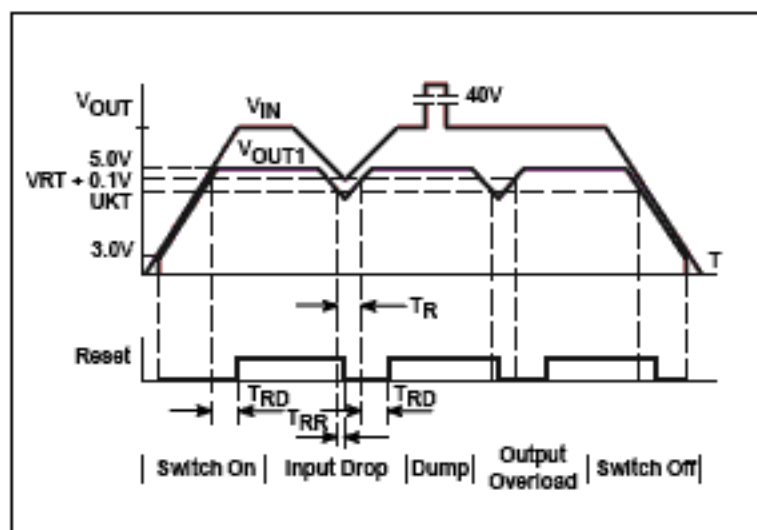

Figure 16. Typical Reset Output Waveforms

Sense Comparator

The sense comparator compares an input signal with an internal voltage reference of typical 1.23V. The use of an external voltage divider makes this comparator very flexible in the application.

It can be used to supervise the input voltage either before or after the protection diode and to give additional information to the microprocessor like low voltage warnings.

Multifunction Very Low Dropout Voltage Regulator

TC4949

TAPING FORM

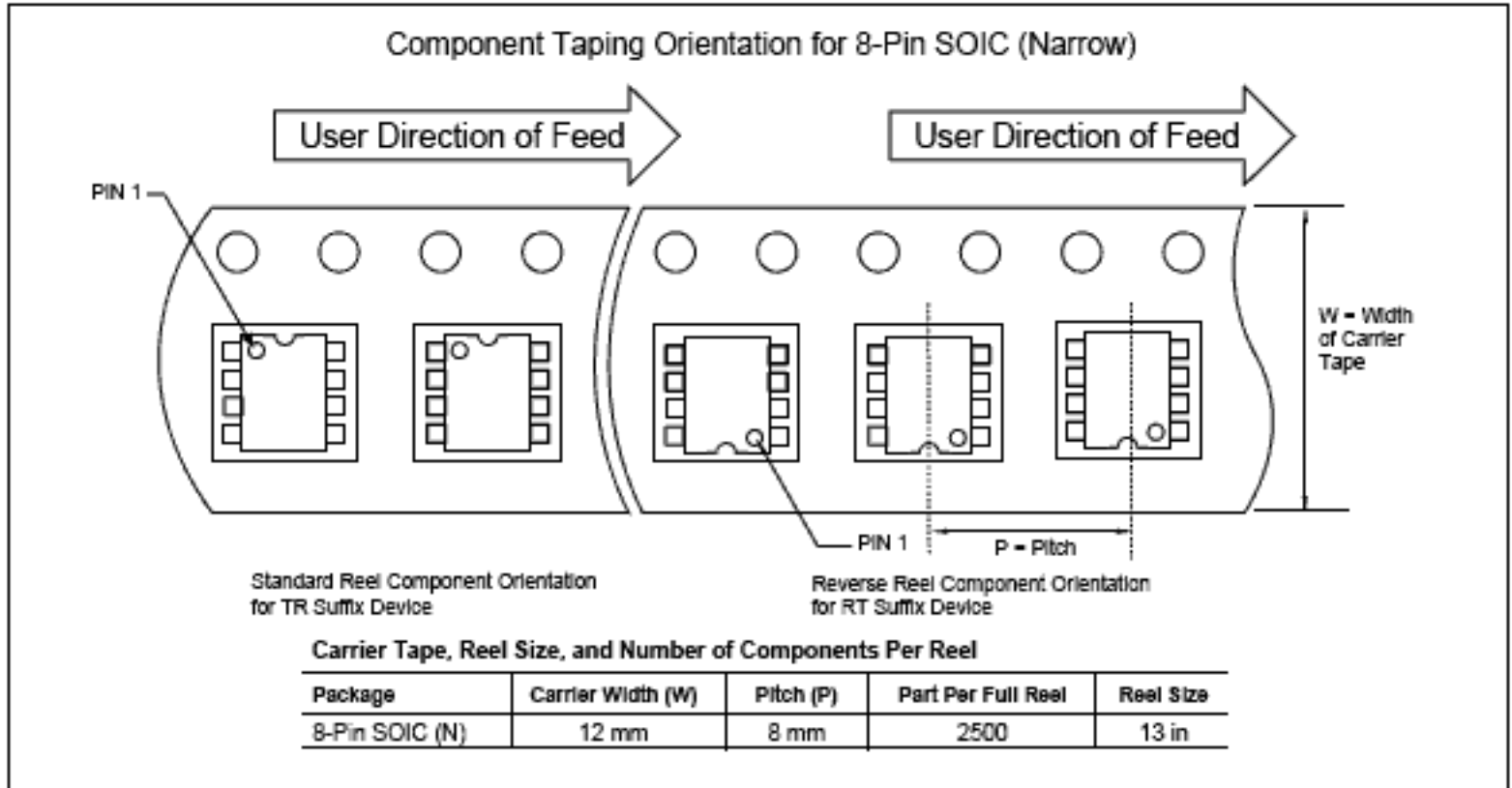

PACKAGE DIMENSIONS

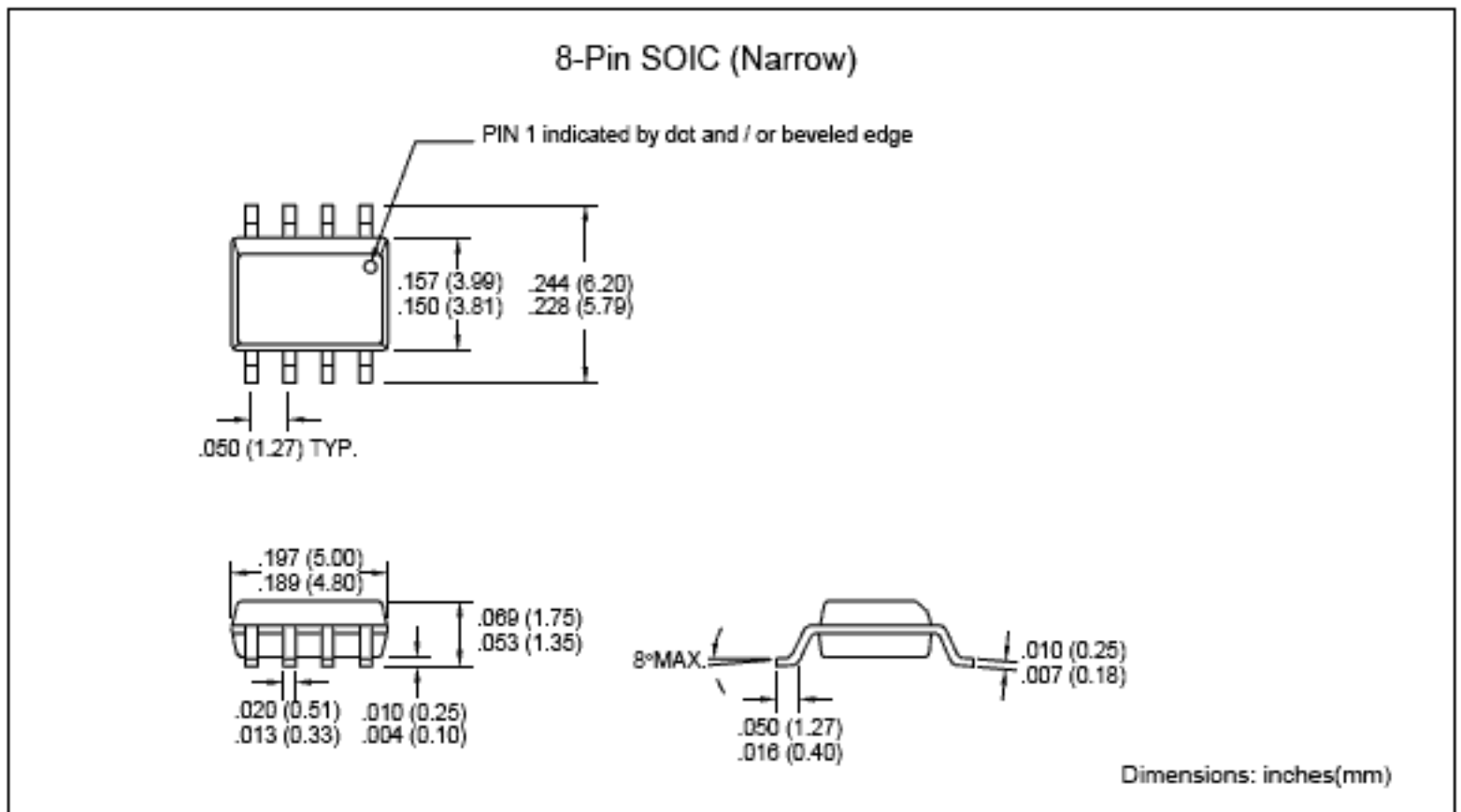

Multifunction Very Low Dropout Voltage Regulator

TC4949

PACKAGE DIMENSIONS (CONT.)

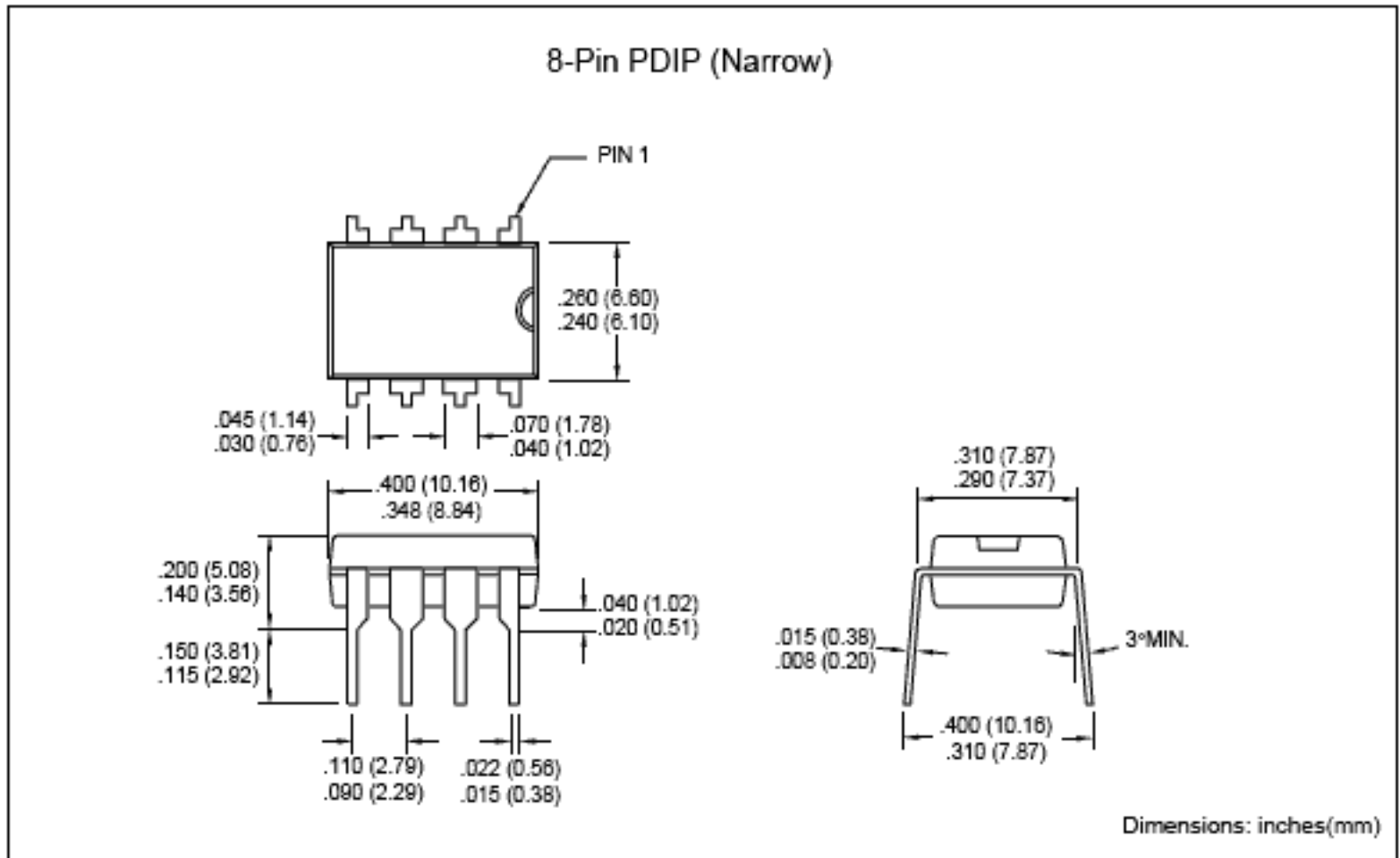

Sales Offices

TelCom Semiconductor, Inc.
1300 Terra Bella Avenue
P.O. Box 7267
Mountain View, CA 94039-7267
TEL: 650-968-9241
FAX: 650-967-1500
E-Mail: liter@telcom-semi.com

TelCom Semiconductor, GmbH
Lochhamer Strasse 13
D-82152 Martinsried
Germany
TEL: (011) 49 89 895 6500
FAX: (011) 49 89 895 6502 2

TelCom Semiconductor H.K. Ltd.
10 Sam Chuk Street, Ground Floor
San Po Kong, Kowloon
Hong Kong
TEL: (011) 852-2350-7380
FAX: (011) 852-2354-9957