



# 27C512A

## 512K (64K x 8) CMOS EPROM

### FEATURES

- High speed performance
- CMOS Technology for low power consumption
  - 25 mA Active current
  - 30  $\mu$ A Standby current
- Factory programming available
- Auto-insertion-compatible plastic packages
- Auto ID aids automated programming
- High speed express programming algorithm
- Organized 64K x 8: JEDEC standard pinouts
  - 28-pin Dual-in-line package
  - 32-pin PLCC Package
  - 28-pin SOIC package
  - 28-pin TSOP package
  - 28-pin VSOP package
  - Tape and reel
- Data Retention > 200 years
- Available for the following temperature ranges
  - Commercial: 0°C to +70°C
  - Industrial: -40°C to +85°C
  - Automotive: -40°C to +125°C

### DESCRIPTION

The Microchip Technology Inc. 27C512A is a CMOS 512K bit electrically Programmable Read Only Memory (EPROM). The device is organized into 64K words by 8 bits (64K bytes). Accessing individual bytes from an address transition or from power-up (chip enable pin going low) is accomplished in less than 90 ns. This very high speed device allows the most sophisticated microprocessors to run at full speed without the need for WAIT states. CMOS design and processing enables this part to be used in systems where reduced power consumption and high reliability are requirements.

A complete family of packages is offered to provide the most flexibility in applications. For surface mount applications, PLCC, VSOP, TSOP or SOIC packaging is available. Tape or reel packaging is also available for PLCC or SOIC packages.

### PACKAGE TYPES

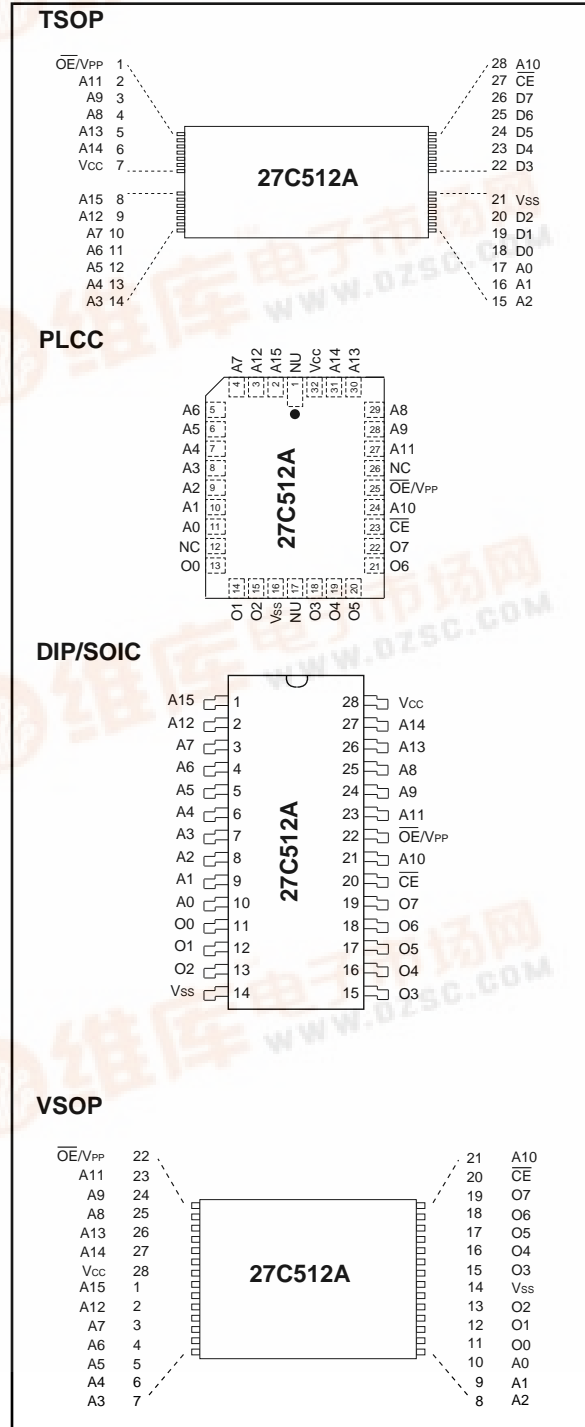

# 27C512A

## 1.0 ELECTRICAL CHARACTERISTICS

### 1.1 Maximum Ratings\*

VCC and input voltages w.r.t. VSS ..... -0.6V to +7.25V

VPP voltage w.r.t. VSS during programming ..... -0.6V to +14V

Voltage on A9 w.r.t. VSS ..... -0.6V to +13.5V

Output voltage w.r.t. VSS ..... -0.6V to VCC +1.0V

Storage temperature ..... -65°C to +150°C

Ambient temp. with power applied ..... -65°C to +125°C

\*Notice: Stresses above those listed under "Maximum Ratings" may cause permanent damage to the device. This is a stress rating only and functional operation of the device at those or any other conditions above those indicated in the operation listings of this specification is not implied. Exposure to maximum rating conditions for extended periods may affect device reliability.

TABLE 1-1: PIN FUNCTION TABLE

Name	Function
A0-A15	Address Inputs
$\overline{CE}$	Chip Enable
$\overline{OE}/V_{PP}$	Output Enable/Programming Voltage
O0 - O7	Data Output
VCC	+5V Power Supply
VSS	Ground
NC	No Connection; No Internal Connection
NU	Not Used; No External Connection is Allowed

TABLE 1-2: READ OPERATION DC CHARACTERISTICS

VCC = +5V ±10% Commercial: Tamb = 0°C to +70°C Industrial: Tamb = -40°C to +85°C Extended (Automotive): Tamb = -40°C to +125°C							
Parameter	Part*	Status	Symbol	Min	Max	Units	Conditions
Input Voltages	all	Logic "1"	V <sub>IH</sub>	2.0	V <sub>CC</sub> +1	V	
		Logic "0"	V <sub>IL</sub>	-0.5	0.8	V	
Input Leakage	all		I <sub>LI</sub>	-10	10	µA	V <sub>IN</sub> = 0 to V <sub>CC</sub>
Output Voltages	all	Logic "1"	V <sub>OH</sub>	2.4		V	I <sub>OH</sub> = - 400 µA I <sub>OL</sub> = 2.1 mA
		Logic "0"	V <sub>OL</sub>		0.45	V	
Output Leakage	all	—	I <sub>LO</sub>	-10	10	µA	V <sub>OUT</sub> = 0V to V <sub>CC</sub>
Input Capacitance	all	—	C <sub>IN</sub>	—	6	pF	V <sub>IN</sub> = 0V; Tamb = 25°C; f = 1 MHz
Output Capacitance	all	—	C <sub>OUT</sub>	—	12	pF	V <sub>OUT</sub> = 0V; Tamb = 25°C; f = 1 MHz
Power Supply Current, Active	C I, E	TTL input	I <sub>CC</sub>	—	25	mA	V <sub>CC</sub> = 5.5V f = 1 MHz; $\overline{OE}/V_{PP} = \overline{CE} = V_{IL}$ ; I <sub>OUT</sub> = 0 mA; V <sub>IL</sub> = -0.1 to 0.8V; V <sub>IH</sub> = 2.0 to V <sub>CC</sub> ; Note 1
		TTL input	I <sub>CC</sub>	—	35	mA	
Power Supply Current, Standby	C	TTL input	I <sub>CC(S)TLL</sub>	—	1	mA	$\overline{CE} = V_{CC} \pm 0.2V$
	I, E	TTL input	I <sub>CC(S)TLL</sub>	—	2	mA	
	all	CMOS input	I <sub>CC(S)CMOS</sub>	—	30	µA	

\* Parts: C=Commercial Temperature Range; I, E=Industrial and Extended Temperature Ranges

Note 1: Typical active current increases .75 mA per MHz up to operating frequency for all temperature ranges.

**TABLE 1-3: READ OPERATION AC CHARACTERISTICS**

Parameter	Sym	27C512-90*		27C512-10*		27C512-12		27C512-15		Units	Conditions
		Min	Max	Min	Max	Min	Max	Min	Max		
		AC Testing Waveform: $V_{IH} = 2.4V$ and $V_{IL} = .45V$ ; $V_{OH} = 2.0V$ and $V_{OL} = 0.8V$ Output Load: 1 TTL Load + 100 pF Input Rise and Fall Times: 10 ns Ambient Temperature: Commercial: $T_{amb} = 0^{\circ}C$ to $+70^{\circ}C$ Industrial: $T_{amb} = -40^{\circ}C$ to $+85^{\circ}C$ Extended (Automotive): $T_{amb} = -40^{\circ}C$ to $+125^{\circ}C$									
Address to Output Delay	tACC	—	90	—	100	—	120	—	150	ns	$\overline{CE} = \overline{OE}/V_{PP} = V_{IL}$
$\overline{CE}$ to Output Delay	tCE	—	90	—	100	—	120	—	150	ns	$\overline{OE}/V_{PP} = V_{IL}$
$\overline{OE}$ to Output Delay	tOE	—	40	—	40	—	50	—	60	ns	$\overline{CE} = V_{IL}$
$\overline{OE}$ to Output High Impedance	tOFF	0	35	0	35	0	40	0	45	ns	
Output Hold from Address, $\overline{CE}$ or $\overline{OE}/V_{PP}$ , whichever occurred first	tOH	0	—	0	—	0	—	0	—	ns	

\*90/10 AC Testing Waveforms:  $V_{IH} = 3.0V$  and  $V_{IL} = 0V$ ;  $V_{OH} = 1.5V$  and  $V_{OL} = 1.5V$   
 Output Load: 1 TTL Load + 30 pF

**FIGURE 1-1: READ WAVEFORMS**

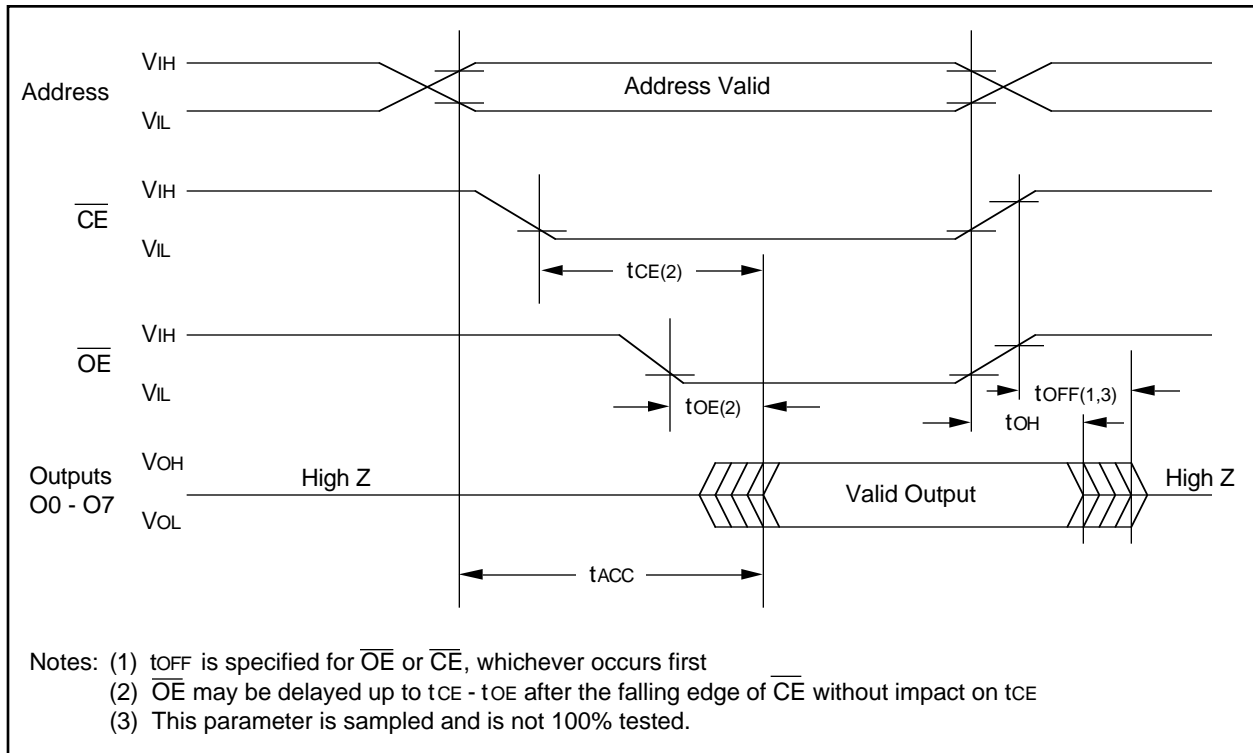

# 27C512A

**TABLE 1-4: PROGRAMMING DC CHARACTERISTICS**

Ambient Temperature: $T_{amb} = 25^{\circ}\text{C} \pm 5^{\circ}\text{C}$ $V_{CC} = 6.5\text{V} \pm 0.25\text{V}$ , $\overline{\text{OE}}/V_{PP} = V_H = 13.0\text{V} \pm 0.25\text{V}$						
Parameter	Status	Symbol	Min.	Max.	Units	Conditions (See Note 1)
Input Voltages	Logic "1"	$V_{IH}$	2.0	$V_{CC}+1$	V	
	Logic "0"	$V_{IL}$	-0.1	0.8	V	
Input Leakage	—	$I_{LI}$	-10	10	$\mu\text{A}$	$V_{IN} = 0\text{V to } V_{CC}$
Output Voltages	Logic "1"	$V_{OH}$	2.4		V	$I_{OH} = -400 \mu\text{A}$
	Logic "0"	$V_{OL}$	—	0.45	V	$I_{OL} = 2.1 \text{ mA}$
VCC Current, program & verify	—	$I_{CC2}$	—	35	mA	$\overline{\text{CE}} = V_{IL}$
$\overline{\text{OE}}/V_{PP}$ Current, program	—	$I_{PP2}$	—	25	mA	
A9 Product Identification	—	$V_{ID}$	11.5	12.5	V	

Note 1:  $V_{CC}$  must be applied simultaneously or before  $V_{PP}$  voltage on  $\overline{\text{OE}}/V_{PP}$  and removed simultaneously or after the  $V_{PP}$  voltage on  $\overline{\text{OE}}/V_{PP}$ .

**TABLE 1-5: PROGRAMMING AC CHARACTERISTICS**

for Program, Program Verify and Program Inhibit Modes		AC Testing Waveform: $V_{IH}=2.4\text{V}$ and $V_{IL}=0.45\text{V}$ ; $V_{OH}=2.0\text{V}$ ; $V_{OL}=0.8\text{V}$ Ambient Temperature: $25^{\circ}\text{C} \pm 5^{\circ}\text{C}$ $V_{CC} = 6.5\text{V} \pm 0.25\text{V}$ , $\overline{\text{OE}}/V_{PP} = V_H = 13.0\text{V} \pm 0.25\text{V}$				
Parameter	Symbol	Min.	Max.	Units	Remarks	
Address Set-Up Time	$t_{AS}$	2	—	$\mu\text{s}$		
Data Set-Up Time	$t_{DS}$	2	—	$\mu\text{s}$		
Data Hold Time	$t_{DH}$	2	—	$\mu\text{s}$		
Address Hold Time	$t_{AH}$	0	—	$\mu\text{s}$		
Float Delay (2)	$t_{DF}$	0	130	ns		
VCC Set-Up Time	$t_{VCS}$	2	—	$\mu\text{s}$		
Program Pulse Width (1)	$t_{PW}$	95	105	$\mu\text{s}$	100 $\mu\text{s}$ typical	
$\overline{\text{CE}}$ Set-Up Time	$t_{CES}$	2	—	$\mu\text{s}$		
$\overline{\text{OE}}$ Set-Up Time	$t_{OES}$	2	—	$\mu\text{s}$		
$\overline{\text{OE}}$ Hold Time	$t_{OEH}$	2	—	$\mu\text{s}$		
$\overline{\text{OE}}$ Recovery Time	$t_{OR}$	2	—	$\mu\text{s}$		
$\overline{\text{OE}}/V_{PP}$ Rise Time During Programming	$t_{PRT}$	50	—	ns		

Note 1: For express algorithm, initial programming width tolerance is 100  $\mu\text{s} \pm 5\%$ .

2: This parameter is only sampled and not 100% tested. Output float is defined as the point where data is no longer driven (see timing diagram).

**FIGURE 1-2: PROGRAMMING WAVEFORMS (1)**

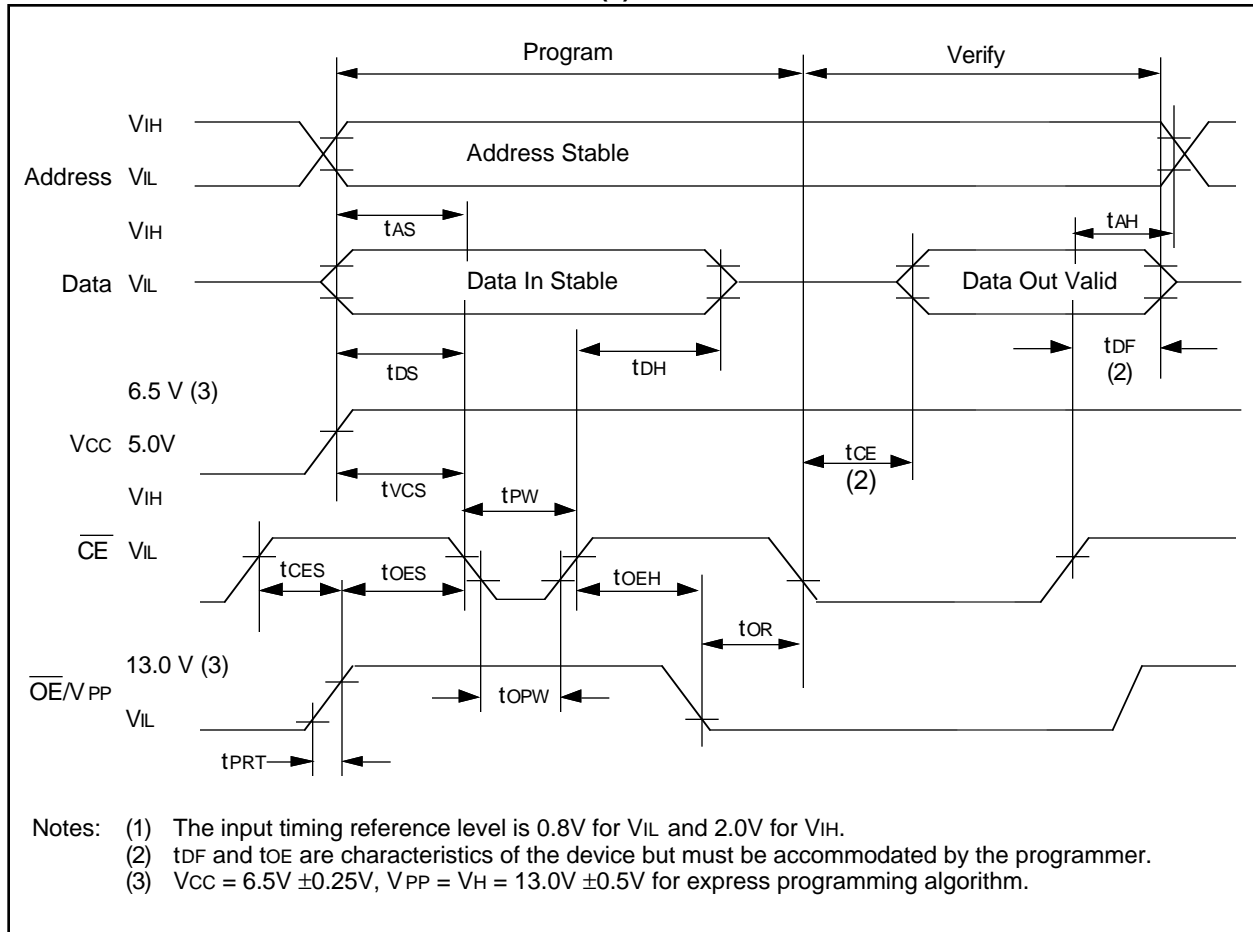

**TABLE 1-6: MODES**

Operation Mode	$\overline{CE}$	$\overline{OE/PP}$	A9	O0 - O7
Read	VIL	VIL	X	DOUT
Program	VIL	VH	X	DIN
Program Verify	VIL	VIL	X	DOUT
Program Inhibit	VIH	VH	X	High Z
Standby	VIH	X	X	High Z
Output Disable	VIL	VIH	X	High Z
Identity	VIL	VIL	VH	Identity Code

X = Don't Care

## 1.2 Read Mode

(See Timing Diagrams and AC Characteristics)

Read Mode is accessed when

- the CE pin is low to power up (enable) the chip
- the OE/VPP pin is low to gate the data to the output pins

For Read operations, if the addresses are stable, the address access time (tACC) is equal to the delay from  $\overline{CE}$  to output (tCE). Data is transferred to the output after a delay (tOE) from the falling edge of  $\overline{OE/VPP}$ .

# 27C512A

## 1.3 Standby Mode

The standby mode is entered when the  $\overline{CE}$  pin is high, and the program mode is not identified.

When this conditions are met, the supply current will drop from 25 mA to 30  $\mu$ A.

## 1.4 Output Enable $\overline{OE}/V_{PP}$

This multifunction pin eliminates bus connection in multiple bus microprocessor systems and the outputs go to high impedance when:

- the  $\overline{OE}/V_{PP}$  pin is high ( $V_{IH}$ ).

When a  $V_H$  input is applied to this pin, it supplies the programming voltage ( $V_{PP}$ ) to the device.

## 1.5 Erase Mode (UV Windowed Versions)

Windowed products offer the ability to erase the memory array. The memory matrix is erased to the all "1's" state as a result of being exposed to ultraviolet light. To ensure complete erasure, a dose of 15 watt-second/ $cm^2$  is required. This means that the device window must be placed within one inch and directly underneath an ultraviolet lamp with a wavelength of 2537 Angstroms, intensity of 12,000 mW/ $cm^2$  for approximately 40 minutes.

## 1.6 Programming Mode

The Express algorithm must be used for best results. It has been developed to improve programming yields and throughput times in a production environment. Up to 10 100-microsecond pulses are applied until the byte is verified. A flowchart of the Express algorithm is shown in Figure 1-3.

Programming takes place when:

- $V_{CC}$  is brought to the proper voltage,
- $\overline{OE}/V_{PP}$  is brought to the proper  $V_H$  level, and
- $\overline{CE}$  line is low.

Since the erased state is "1" in the array, programming of "0" is required. The address to be programmed is set via pins A0 - A15 and the data to be programmed is presented to pins O0 - O7. When data and address are stable, a low going pulse on the  $\overline{CE}$  line programs that location.

## 1.7 Verify

After the array has been programmed it must be verified to ensure all the bits have been correctly programmed. This mode is entered when all the following conditions are met:

- $V_{CC}$  is at the proper level,
- the  $\overline{OE}/V_{PP}$  pin is low, and
- the  $\overline{CE}$  line is low.

## 1.8 Inhibit

When programming multiple devices in parallel with different data, only  $\overline{CE}$  needs to be under separate control to each device. By pulsing the  $\overline{CE}$  line low on a particular device, that device will be programmed; all other devices with  $\overline{CE}$  held high will not be programmed with the data (although address and data will be available on their input pins).

## 1.9 Identity Mode

In this mode specific data is output which identifies the manufacturer as Microchip Technology Inc. and the device type. This mode is entered when Pin A9 is taken to  $V_H$  (11.5V to 12.5V). The  $\overline{CE}$  and  $\overline{OE}/V_{PP}$  lines must be at  $V_{IL}$ . A0 is used to access any of the two non-erasable bytes whose data appears on O0 through O7.

Pin $\rightarrow$	Input	Output								
Identity $\downarrow$	A0	0 7	0 6	0 5	0 4	0 3	0 2	0 1	0 0	H e x
	Manufacturer	$V_{IL}$	0	0	1	0	1	0	0	1
Device Type*	$V_{IH}$	1	0	0	0	1	1	0	0	0D

\* Code subject to change

FIGURE 1-3: PROGRAMMING EXPRESS ALGORITHM

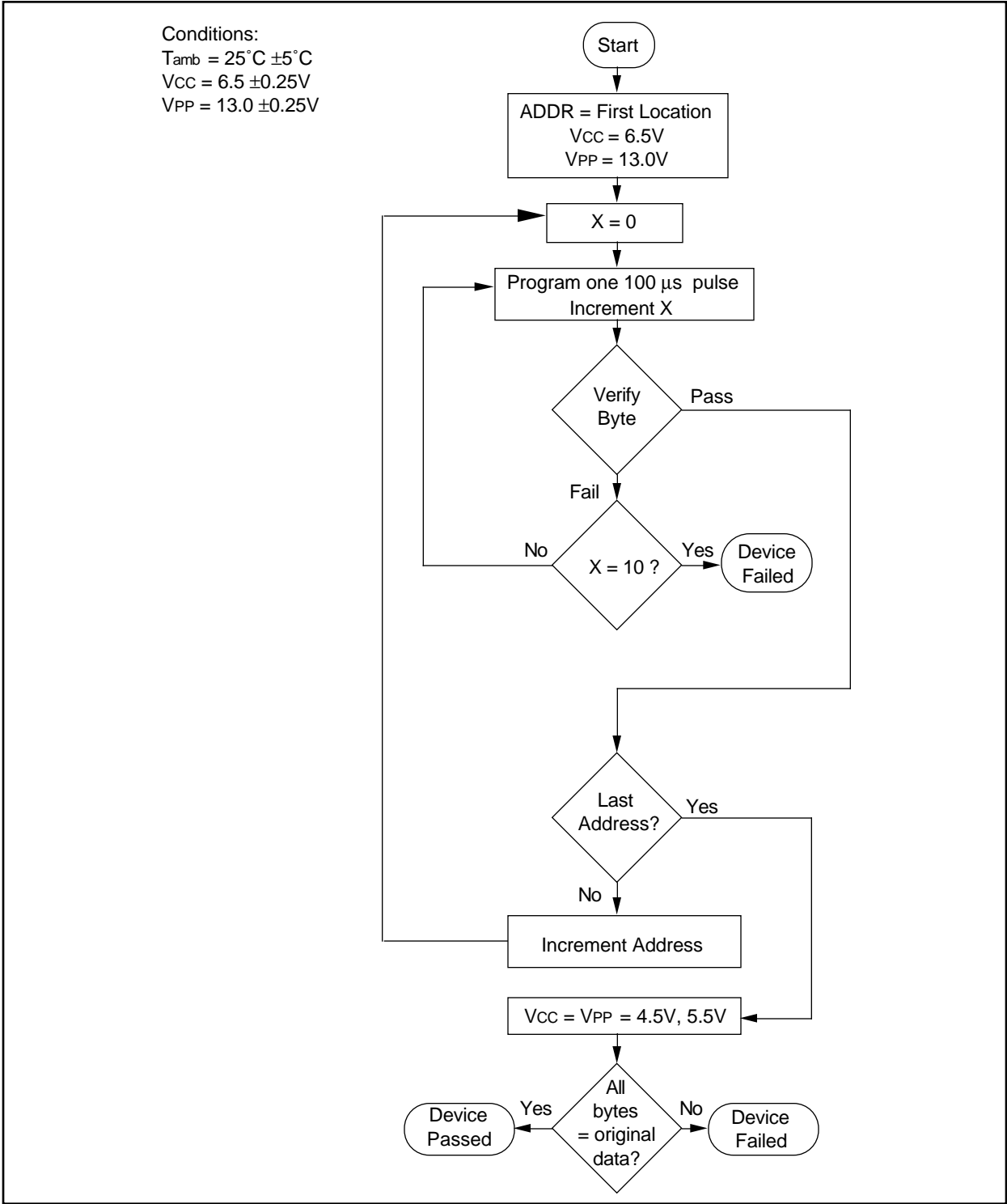

# 27C512A

---

---

NOTES:



**NOTES:**

# 27C512A

---

---

NOTES:

# 27C512A

## 27C512A Product Identification System

To order or to obtain information (e.g., on pricing or delivery), please use listed part numbers, and refer to factory or listed sales offices.

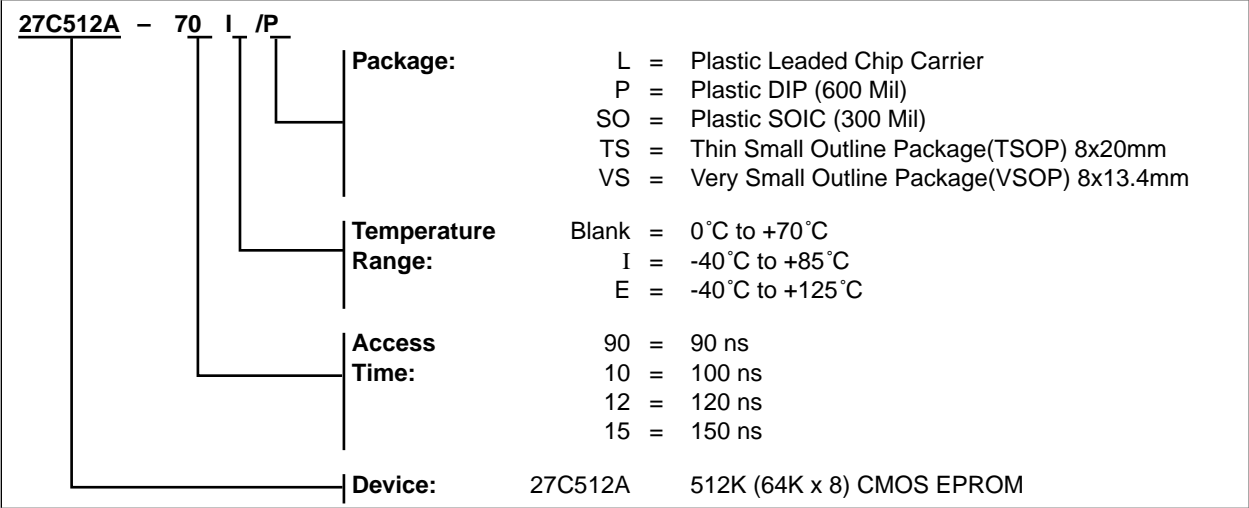

---

---

# WORLDWIDE SALES & SERVICE

---

---

## AMERICAS

### Corporate Office

Microchip Technology Inc.  
2355 West Chandler Blvd.  
Chandler, AZ 85224-6199  
Tel: 602 786-7200 Fax: 602 786-7277  
Technical Support: 602 786-7627  
Web: <http://www.microchip.com>

### Atlanta

Microchip Technology Inc.  
500 Sugar Mill Road, Suite 200B  
Atlanta, GA 30350  
Tel: 770 640-0034 Fax: 770 640-0307

### Boston

Microchip Technology Inc.  
5 Mount Royal Avenue  
Marlborough, MA 01752  
Tel: 508 480-9990 Fax: 508 480-8575

### Chicago

Microchip Technology Inc.  
333 Pierce Road, Suite 180  
Itasca, IL 60143  
Tel: 708 285-0071 Fax: 708 285-0075

### Dallas

Microchip Technology Inc.  
14651 Dallas Parkway, Suite 816  
Dallas, TX 75240-8809  
Tel: 972 991-7177 Fax: 972 991-8588

### Dayton

Microchip Technology Inc.  
Suite 150  
Two Prestige Place  
Miamisburg, OH 45342  
Tel: 513 291-1654 Fax: 513 291-9175

### Los Angeles

Microchip Technology Inc.  
18201 Von Karman, Suite 1090  
Irvine, CA 92612  
Tel: 714 263-1888 Fax: 714 263-1338

### New York

Microchip Technmgy Inc.  
150 Motor Parkway, Suite 416  
Hauppauge, NY 11788  
Tel: 516 273-5305 Fax: 516 273-5335

### San Jose

Microchip Technology Inc.  
2107 North First Street, Suite 590  
San Jose, CA 95131  
Tel: 408 436-7950 Fax: 408 436-7955

### Toronto

Microchip Technology Inc.  
5925 Airport Road, Suite 200  
Mississauga, Ontario L4V 1W1, Canada  
Tel: 905 405-6279 Fax: 905 405-6253

## ASIA/PACIFIC

### China

Microchip Technology  
Unit 406 of Shanghai Golden Bridge Bldg.  
2077 Yan'an Road West, Hongjiao District  
Shanghai, Peoples Republic of China  
Tel: 86 21 6275 5700  
Fax: 011 86 21 6275 5060

### Hong Kong

Microchip Technology  
RM 3801B, Tower Two  
Metroplaza  
223 Hing Fong Road  
Kwai Fong, N.T. Hong Kong  
Tel: 852 2 401 1200 Fax: 852 2 401 3431

### India

Microchip Technology  
No. 6, Legacy, Convent Road  
Bangalore 560 025 India  
Tel: 91 80 526 3148 Fax: 91 80 559 9840

### Korea

Microchip Technology  
168-1, Youngbo Bldg. 3 Floor  
Samsung-Dong, Kangnam-Ku,  
Seoul, Korea  
Tel: 82 2 554 7200 Fax: 82 2 558 5934

### Singapore

Microchip Technology  
200 Middle Road  
#10-03 Prime Centre  
Singapore 188980  
Tel: 65 334 8870 Fax: 65 334 8850

### Taiwan, R.O.C

Microchip Technology  
10F-1C 207  
Tung Hua North Road  
Taipei, Taiwan, ROC  
Tel: 886 2 717 7175 Fax: 886 2 545 0139

## EUROPE

### United Kingdom

Arizona Microchip Technology Ltd.  
Unit 6, The Courtyard  
Meadow Bank, Furlong Road  
Bourne End, Buckinghamshire SL8 5AJ  
Tel: 44 1628 850303 Fax: 44 1628 850178

### France

Arizona Microchip Technology SARL  
Zone Industrielle de la Bonde  
2 Rue du Buisson aux Fraises  
91300 Massy - France  
Tel: 33 1 69 53 63 20 Fax: 33 1 69 30 90 79

### Germany

Arizona Microchip Technology GmbH  
Gustav-Heinemann-Ring 125  
D-81739 Muenchen, Germany  
Tel: 49 89 627 144 0 Fax: 49 89 627 144 44

### Italy

Arizona Microchip Technology SRL  
Centro Direzionale Colleone Pas Taurus 1  
Viale Colleoni 1  
20041 Agrate Brianza  
Milan Italy  
Tel: 39 39 6899939 Fax: 39 39 689 9883

### JAPAN

Microchip Technology Intl. Inc.  
Benex S-1 6F  
3-18-20, Shin Yokohama  
Kohoku-Ku, Yokohama  
Kanagawa 222 Japan  
Tel: 81 45 471 6166 Fax: 81 45 471 6122

9/3/96



**MICROCHIP**

All rights reserved. © 1996, Microchip Technology Incorporated, USA. 9/96



Printed on recycled paper.

Information contained in this publication regarding device applications and the like is intended through suggestion only and may be superseded by updates. No representation or warranty is given and no liability is assumed by Microchip Technology Incorporated with respect to the accuracy or use of such information, or infringement of patents or other intellectual property rights arising from such use or otherwise. Use of Microchip's products as critical components in life support systems is not authorized except with express written approval by Microchip. No licenses are conveyed, implicitly or otherwise, under any intellectual property rights. The Microchip logo and name are registered trademarks of Microchip Technology Inc. All rights reserved. All other trademarks mentioned herein are the property of their respective companies.