



# MCP3221

## Low Power 12-Bit A/D Converter With I<sup>2</sup>C™ Interface

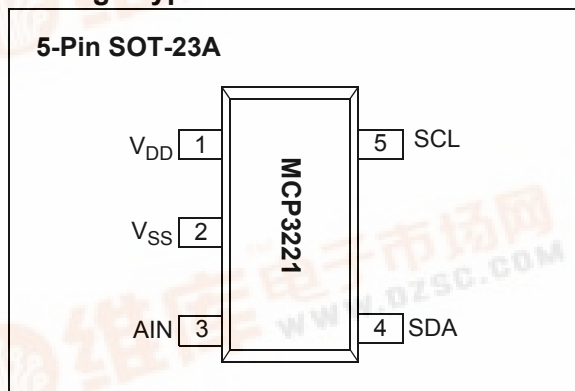
### Features

- 12-bit resolution
- $\pm 1$  LSB DNL,  $\pm 2$  LSB INL max.
- 250  $\mu$ A max conversion current
- 5 nA typical standby current, 1  $\mu$ A max.
- I<sup>2</sup>C™ compatible serial interface
  - 100 kHz I<sup>2</sup>C Standard Mode
  - 400 kHz I<sup>2</sup>C Fast Mode
- Up to 8 devices on a single 2-Wire bus
- 22.3 ksp/s in I<sup>2</sup>C Fast Mode
- Single-ended analog input channel
- On-chip sample and hold
- On-chip conversion clock
- Single-supply specified operation: 2.7V to 5.5V
- Temperature range:
  - Industrial: -40°C to +85°C
  - Extended: -40°C to +125°C
- Small SOT-23 package

### Applications

- Data Logging
- Multi-zone Monitoring
- Hand-Held Portable Applications
- Battery-Powered Test Equipment
- Remote or Isolated Data Acquisition

### Package Type



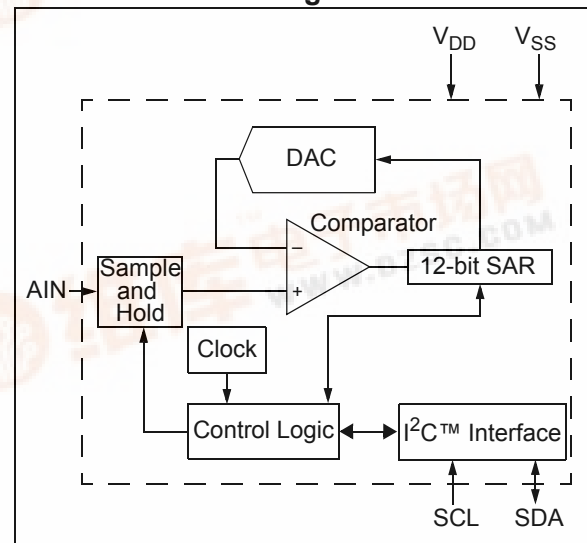
### Description

The Microchip Technology Inc. MCP3221 is a successive approximation A/D converter with 12-bit resolution. Available in the SOT-23 package, this device provides one single-ended input with very low power consumption. Based on an advanced CMOS technology, the MCP3221 provides a low maximum conversion current and standby current of 250  $\mu$ A and 1  $\mu$ A, respectively. Low current consumption, combined with the small SOT-23 package, make this device ideal for battery-powered and remote data acquisition applications.

Communication to the MCP3221 is performed using a 2-wire, I<sup>2</sup>C compatible interface. Standard (100 kHz) and Fast (400 kHz) I<sup>2</sup>C modes are available with the device. An on-chip conversion clock enables independent timing for the I<sup>2</sup>C and conversion clocks. The device is also addressable, allowing up to eight devices on a single 2-wire bus.

The MCP3221 runs on a single supply voltage that operates over a broad range of 2.7V to 5.5V. This device also provides excellent linearity of  $\pm 1$  LSB differential non-linearity and  $\pm 2$  LSB integral non-linearity, maximum.

### Functional Block Diagram



# MCP3221

## 1.0 ELECTRICAL CHARACTERISTICS

### Absolute Maximum Ratings †

V <sub>DD</sub> .....	7.0V
Analog input pin w.r.t. V <sub>SS</sub> .....	-0.6V to V <sub>DD</sub> +0.6V
SDA and SCL pins w.r.t. V <sub>SS</sub> .....	-0.6V to V <sub>DD</sub> +1.0V
Storage temperature .....	-65°C to +150°C
Ambient temp. with power applied .....	-65°C to +125°C
Maximum Junction Temperature .....	150°C
ESD protection on all pins (HBM) .....	≥ 4 kV

† Stresses above those listed under “Maximum ratings” may cause permanent damage to the device. This is a stress rating only and functional operation of the device at those or any other conditions above those indicated in the operational listings of this specification is not implied. Exposure to maximum rating conditions for extended periods may affect device reliability.

## PIN FUNCTION TABLE

Name	Function
V <sub>DD</sub>	+2.7V to 5.5V Power Supply
V <sub>SS</sub>	Ground
AIN	Analog Input
SDA	Serial Data In/Out
SCL	Serial Clock In

## DC ELECTRICAL SPECIFICATIONS

**Electrical Characteristics:** Unless otherwise noted, all parameters apply at V<sub>DD</sub> = 5.0V, V<sub>SS</sub> = GND, R<sub>PJ</sub> = 2 kΩ  
T<sub>AMB</sub> = -40°C to +85°C, I<sup>2</sup>C Fast Mode Timing: f<sub>SCL</sub> = 400 kHz (**Note 3**).

Parameters	Sym	Min	Typ	Max	Units	Conditions
<b>DC Accuracy</b>						
Resolution			12		bits	
Integral Nonlinearity	INL	—	±0.75	±2	LSB	
Differential Nonlinearity	DNL	—	±0.5	±1	LSB	No missing codes
Offset Error		—	±0.75	±2	LSB	
Gain Error		—	-1	±3	LSB	
<b>Dynamic Performance</b>						
Total Harmonic Distortion	THD	—	-82	—	dB	V <sub>IN</sub> = 0.1V to 4.9V @ 1 kHz
Signal-to-Noise and Distortion	SINAD	—	72	—	dB	V <sub>IN</sub> = 0.1V to 4.9V @ 1 kHz
Spurious-Free Dynamic Range	SFDR	—	86	—	dB	V <sub>IN</sub> = 0.1V to 4.9V @ 1 kHz
<b>Analog Input</b>						
Input Voltage Range		V <sub>SS</sub> -0.3	—	V <sub>DD</sub> +0.3	V	2.7V ≤ V <sub>DD</sub> ≤ 5.5V
Leakage Current		-1	—	+1	μA	
<b>SDA/SCL (open-drain output):</b>						
Data Coding Format		Straight Binary				
High-level input voltage	V <sub>IH</sub>	0.7 V <sub>DD</sub>	—	—	V	
Low-level input voltage	V <sub>IL</sub>	—	—	0.3 V <sub>DD</sub>	V	
Low-level output voltage	V <sub>OL</sub>	—	—	0.4	V	I <sub>OL</sub> = 3 mA, R <sub>PJ</sub> = 1.53 kΩ
Hysteresis of Schmitt trigger inputs	V <sub>HYST</sub>	—	0.05 V <sub>DD</sub>	—	V	f <sub>SCL</sub> = 400 kHz only

- Note 1:** “Sample time” is the time between conversions once the address byte has been sent to the converter. Refer to Figure 5-6.
- 2:** This parameter is periodically sampled and not 100% tested.
- 3:** R<sub>PJ</sub> = Pull-up resistor on SDA and SCL.
- 4:** SDA and SCL = V<sub>SS</sub> to V<sub>DD</sub> at 400 kHz.
- 5:** t<sub>ACQ</sub> and t<sub>CONV</sub> are dependent on internal oscillator timing. See Figure 5-5 and Figure 5-6 for relation to SCL.

# MCP3221

## DC ELECTRICAL SPECIFICATIONS (CONTINUED)

<b>Electrical Characteristics:</b> Unless otherwise noted, all parameters apply at $V_{DD} = 5.0V$ , $V_{SS} = GND$ , $R_{PU} = 2\text{ k}\Omega$ , $T_{AMB} = -40^{\circ}\text{C}$ to $+85^{\circ}\text{C}$ , I <sup>2</sup> C Fast Mode Timing: $f_{SCL} = 400\text{ kHz}$ ( <b>Note 3</b> ).						
Parameters	Sym	Min	Typ	Max	Units	Conditions
Input leakage current	$I_{LI}$	-1	—	+1	$\mu\text{A}$	$V_{IN} = 0.1 V_{DD}$ and $0.9 V_{DD}$
Output leakage current	$I_{LO}$	-1	—	+1	$\mu\text{A}$	$V_{OUT} = 0.1 V_{SS}$ and $0.9 V_{DD}$
Pin capacitance (all inputs/outputs)	$C_{IN}$ , $C_{OUT}$	—	—	10	pF	$T_{AMB} = 25^{\circ}\text{C}$ , $f = 1\text{ MHz}$ ; ( <b>Note 2</b> )
Bus Capacitance	$C_B$	—	—	400	pF	SDA drive low, 0.4V
<b>Power Requirements</b>						
Operating Voltage	$V_{DD}$	2.7	—	5.5	V	
Conversion Current	$I_{DD}$	—	175	250	$\mu\text{A}$	
Standby Current	$I_{DDS}$	—	0.005	1	$\mu\text{A}$	SDA, SCL = $V_{DD}$
Active bus current	$I_{DDA}$	—	—	120	$\mu\text{A}$	<b>Note 4</b>
<b>Conversion Rate</b>						
Conversion Time	$t_{CONV}$	—	8.96	—	$\mu\text{s}$	<b>Note 5</b>
Analog Input Acquisition Time	$t_{ACQ}$	—	1.12	—	$\mu\text{s}$	<b>Note 5</b>
Sample Rate	$f_{SAMP}$	—	—	22.3	ksps	$f_{SCL} = 400\text{ kHz}$ ( <b>Note 1</b> )

- Note 1:** “Sample time” is the time between conversions once the address byte has been sent to the converter. Refer to Figure 5-6.
- 2:** This parameter is periodically sampled and not 100% tested.
- 3:**  $R_{PU}$  = Pull-up resistor on SDA and SCL.
- 4:** SDA and SCL =  $V_{SS}$  to  $V_{DD}$  at 400 kHz.
- 5:**  $t_{ACQ}$  and  $t_{CONV}$  are dependent on internal oscillator timing. See Figure 5-5 and Figure 5-6 for relation to SCL.

## TEMPERATURE SPECIFICATIONS

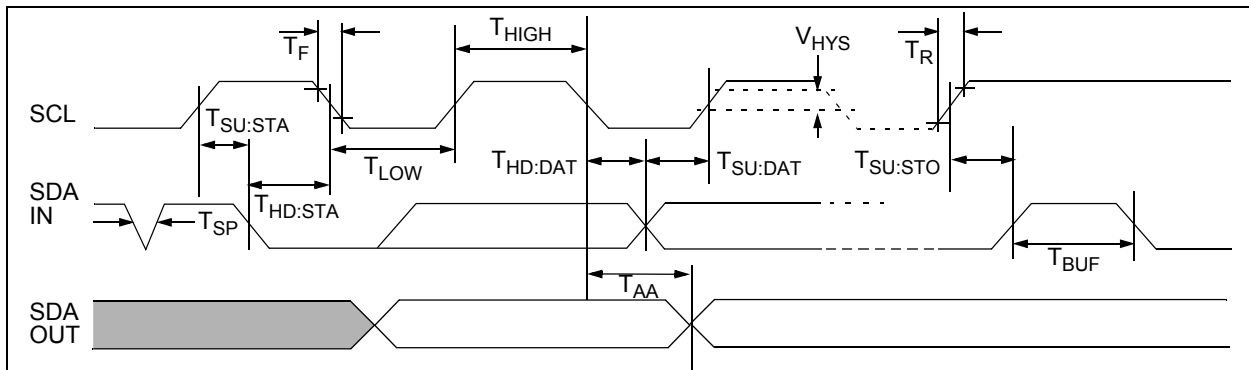
<b>Electrical Characteristics:</b> Unless otherwise noted, all parameters apply at $V_{DD} = 5.0V$ , $V_{SS} = GND$ .						
Parameters	Symbol	Min	Typ	Max	Units	Conditions
<b>Temperature Ranges</b>						
Industrial Temperature Range	$T_A$	-40	—	+85	$^{\circ}\text{C}$	
Extended Temperature Range	$T_A$	-40	—	+125	$^{\circ}\text{C}$	
Operating Temperature Range	$T_A$	-40	—	+125	$^{\circ}\text{C}$	
Storage Temperature Range	$T_A$	-65	—	+150	$^{\circ}\text{C}$	
<b>Thermal Package Resistances</b>						
Thermal Resistance, 5L-SOT23A	$\theta_{JA}$	—	256	—	$^{\circ}\text{C/W}$	

# MCP3221

## TIMING SPECIFICATIONS

Electrical Characteristics: All parameters apply at $V_{DD} = 2.7V - 5.5V$ , $V_{SS} = GND$ , $T_{AMB} = -40^{\circ}C$ to $+85^{\circ}C$ .						
Parameters	Sym	Min	Typ	Max	Units	Conditions
<b>I<sup>2</sup>C Standard Mode</b>						
Clock frequency	$f_{SCL}$	0	—	100	kHz	
Clock high time	$T_{HIGH}$	4000	—	—	ns	
Clock low time	$T_{LOW}$	4700	—	—	ns	
SDA and SCL rise time	$T_R$	—	—	1000	ns	From $V_{IL}$ to $V_{IH}$ (Note 1)
SDA and SCL fall time	$T_F$	—	—	300	ns	From $V_{IL}$ to $V_{IH}$ (Note 1)
START condition hold time	$T_{HD:STA}$	4000	—	—	ns	
START condition setup time	$T_{SU:STA}$	4700	—	—	ns	
Data input setup time	$T_{SU:DAT}$	250	—	—	ns	
STOP condition setup time	$T_{SU:STO}$	4000	—	—	ns	
STOP condition hold time	$T_{HD:STD}$	4000	—	—	ns	
Output valid from clock	$T_{AA}$	—	—	3500	ns	
Bus free time	$T_{BUF}$	4700	—	—	ns	Note 2
Input filter spike suppression	$T_{SP}$	—	—	50	ns	SDA and SCL pins (Note 1)
<b>I<sup>2</sup>C Fast Mode</b>						
Clock frequency	$F_{SCL}$	0	—	400	kHz	
Clock high time	$T_{HIGH}$	600	—	—	ns	
Clock low time	$T_{LOW}$	1300	—	—	ns	
SDA and SCL rise time	$T_R$	$20 + 0.1C_B$	—	300	ns	From $V_{IL}$ to $V_{IH}$ (Note 1)
SDA and SCL fall time	$T_F$	$20 + 0.1C_B$	—	300	ns	From $V_{IL}$ to $V_{IH}$ (Note 1)
START condition hold time	$T_{HD:STA}$	600	—	—	ns	
START condition setup time	$T_{SU:STA}$	600	—	—	ns	
Data input hold time	$T_{HD:DAT}$	0	—	0.9	ms	
Data input setup time	$T_{SU:DAT}$	100	—	—	ns	
STOP condition setup time	$T_{SU:STO}$	600	—	—	ns	
STOP condition hold time	$T_{HD:STD}$	600	—	—	ns	
Output valid from clock	$T_{AA}$	—	—	900	ns	
Bus free time	$T_{BUF}$	1300	—	—	ns	Note 2
Input filter spike suppression	$T_{SP}$	—	—	50	ns	SDA and SCL pins (Note 1)

- Note 1:** This parameter is periodically sampled and not 100% tested.  
**Note 2:** Time the bus must be free before a new transmission can start.

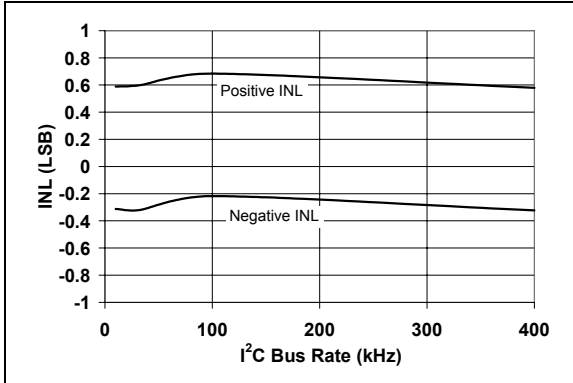


**FIGURE 1-1:** Standard and Fast Mode Bus Timing Data.

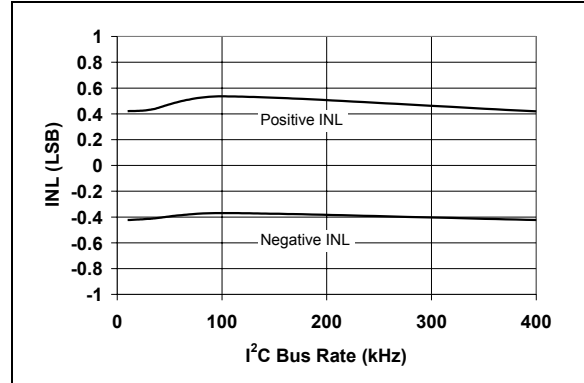
## 2.0 TYPICAL PERFORMANCE CURVES

**Note:** The graphs and tables provided following this note are a statistical summary based on a limited number of samples and are provided for informational purposes only. The performance characteristics listed herein are not tested or guaranteed. In some graphs or tables, the data presented may be outside the specified operating range (e.g., outside specified power supply range) and therefore outside the warranted range.

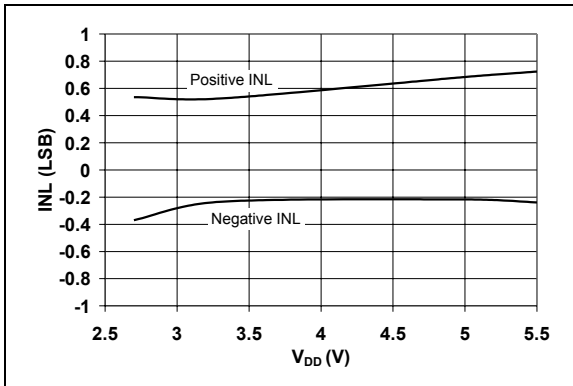
**Note:** Unless otherwise indicated,  $V_{DD} = 5V$ ,  $V_{SS} = 0V$ , I<sup>2</sup>C Fast Mode Timing (SCL = 400 kHz), Continuous Conversion Mode ( $f_{SAMP} = 22.3$  ksp/s),  $T_A = +25^{\circ}C$ .



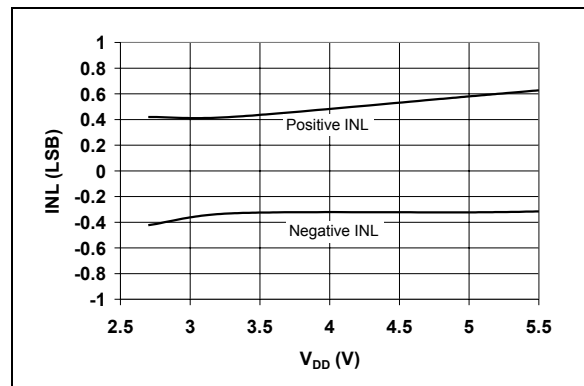
**FIGURE 2-1:** INL vs. Clock Rate.



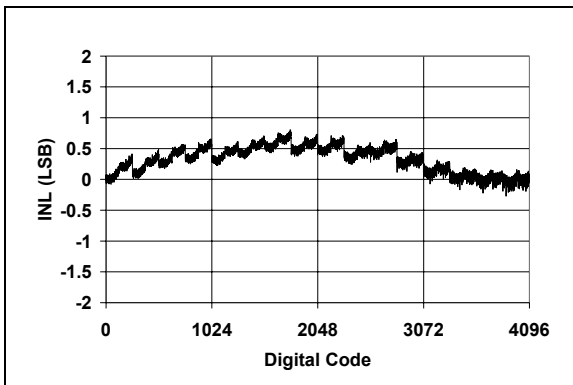
**FIGURE 2-4:** INL vs. Clock Rate ( $V_{DD} = 2.7V$ ).



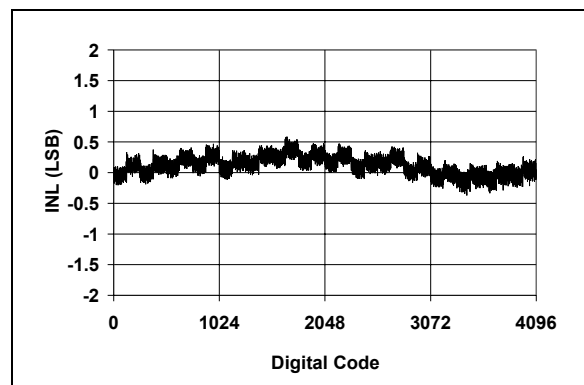
**FIGURE 2-2:** INL vs.  $V_{DD} - I^2C^{\text{TM}}$  Standard Mode ( $f_{SCL} = 100$  kHz).



**FIGURE 2-5:** INL vs.  $V_{DD} - I^2C^{\text{TM}}$  Fast Mode ( $f_{SCL} = 400$  kHz).



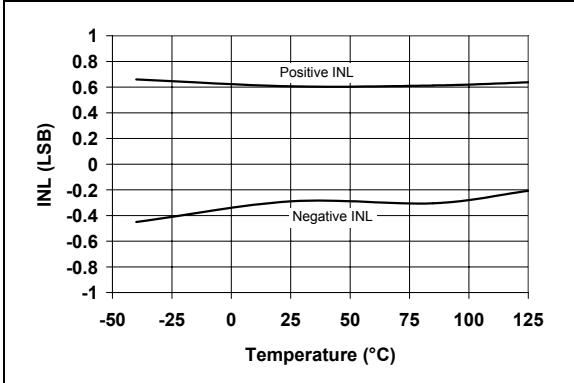
**FIGURE 2-3:** INL vs. Code (Representative Part).



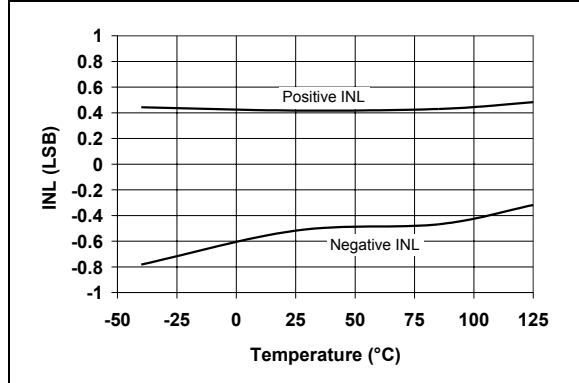
**FIGURE 2-6:** INL vs. Code (Representative Part,  $V_{DD} = 2.7V$ ).

# MCP3221

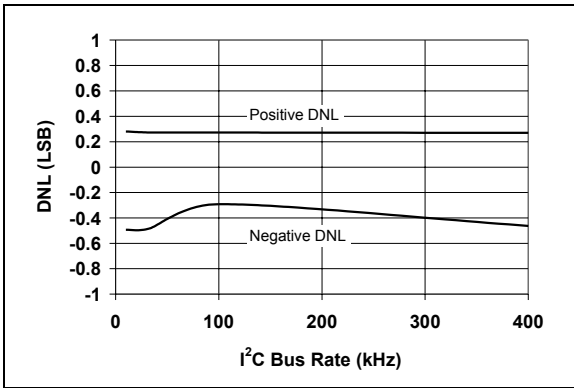
**Note:** Unless otherwise indicated,  $V_{DD} = 5V$ ,  $V_{SS} = 0V$ ,  $I^2C$  Fast Mode Timing ( $SCL = 400$  kHz), Continuous Conversion Mode ( $f_{SAMP} = 22.3$  kps),  $T_A = +25^\circ C$ .



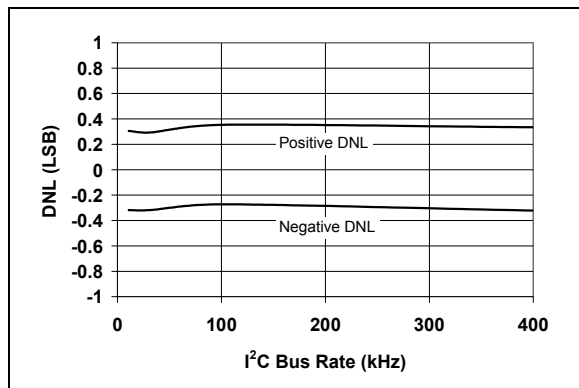
**FIGURE 2-7:** INL vs. Temperature.



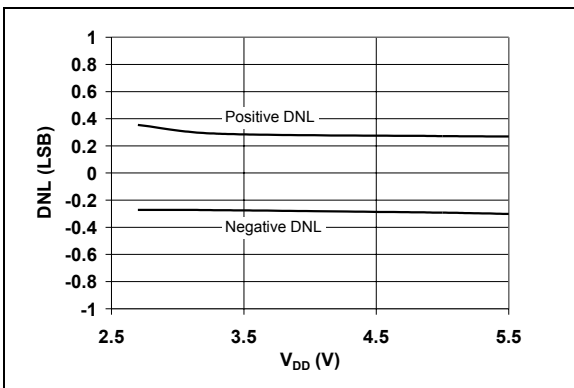
**FIGURE 2-10:** INL vs. Temperature ( $V_{DD} = 2.7V$ ).



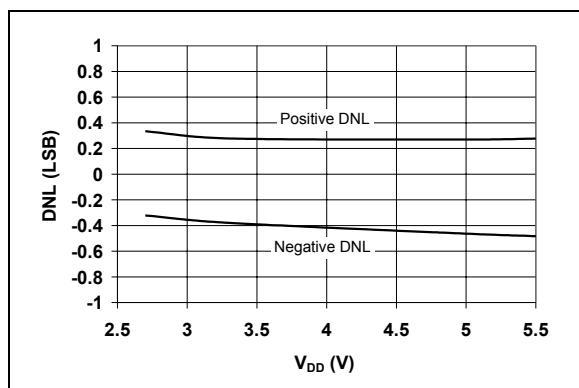
**FIGURE 2-8:** DNL vs. Clock Rate.



**FIGURE 2-11:** DNL vs. Clock Rate ( $V_{DD} = 2.7V$ ).



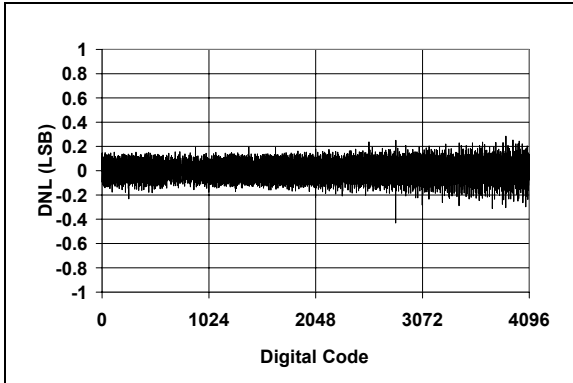
**FIGURE 2-9:** DNL vs.  $V_{DD}$  -  $I^2C$ ™ Standard Mode ( $f_{SCL} = 100$  kHz).



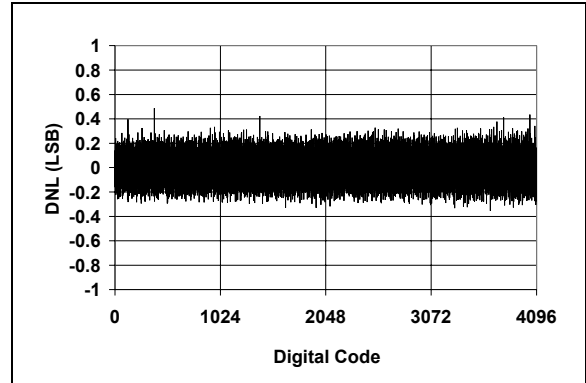
**FIGURE 2-12:** DNL vs.  $V_{DD}$  -  $I^2C$ ™ Fast Mode ( $f_{SCL} = 400$  kHz).

# MCP3221

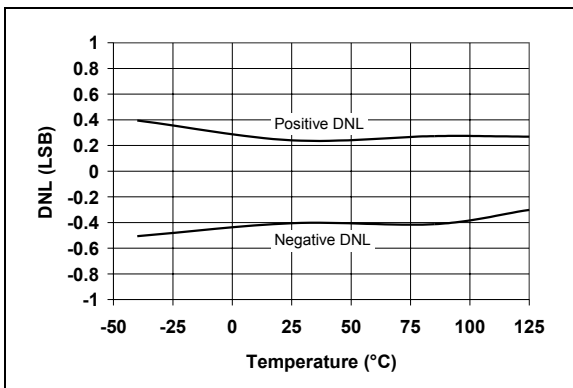
**Note:** Unless otherwise indicated,  $V_{DD} = 5V$ ,  $V_{SS} = 0V$ , I<sup>2</sup>C Fast Mode Timing (SCL = 400 kHz), Continuous Conversion Mode ( $f_{SAMP} = 22.3$  ksp/s),  $T_A = +25^{\circ}C$ .



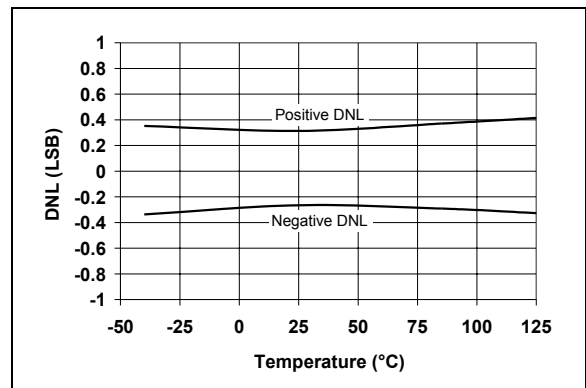
**FIGURE 2-13:** DNL vs. Code (Representative Part).



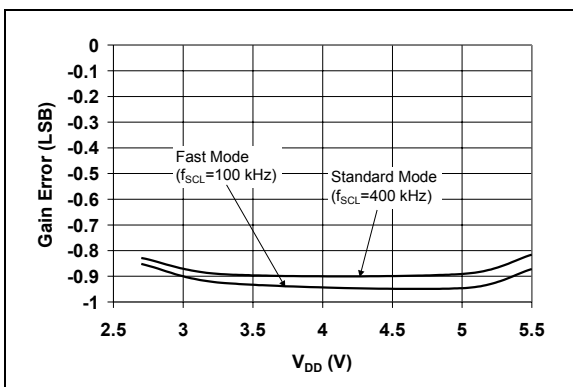
**FIGURE 2-16:** DNL vs. Code (Representative Part,  $V_{DD} = 2.7V$ ).



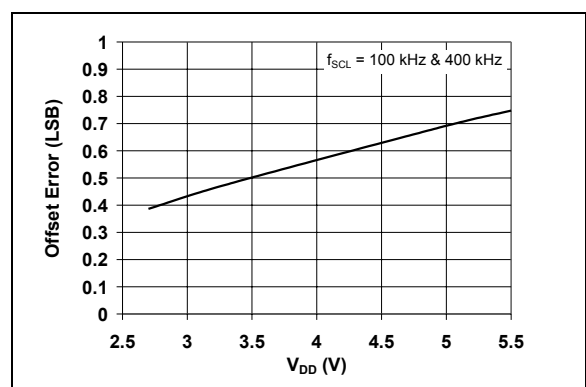
**FIGURE 2-14:** DNL vs. Temperature.



**FIGURE 2-17:** DNL vs. Temperature ( $V_{DD} = 2.7V$ ).



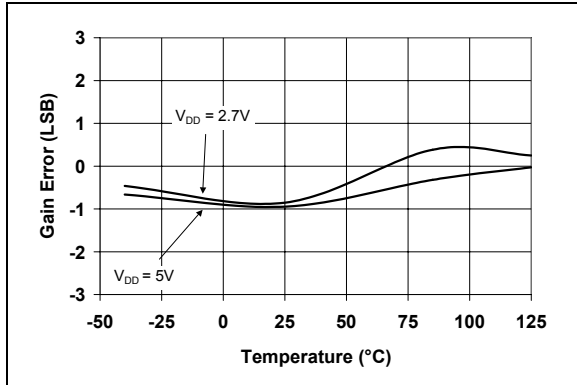
**FIGURE 2-15:** Gain Error vs.  $V_{DD}$ .



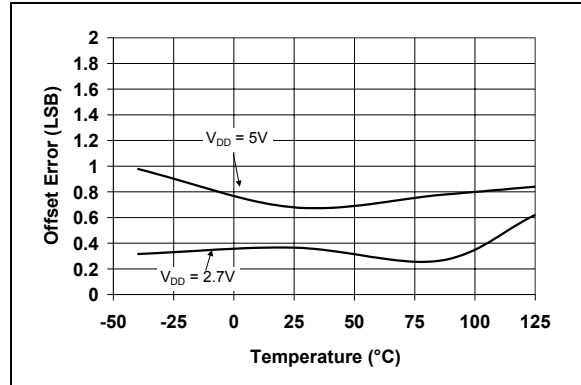
**FIGURE 2-18:** Offset Error vs.  $V_{DD}$ .

# MCP3221

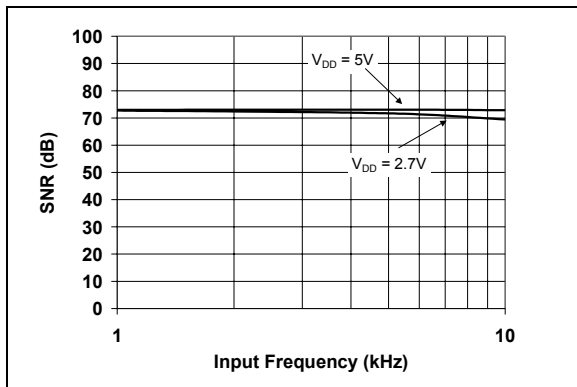
**Note:** Unless otherwise indicated,  $V_{DD} = 5V$ ,  $V_{SS} = 0V$ , I<sup>2</sup>C Fast Mode Timing (SCL = 400 kHz), Continuous Conversion Mode ( $f_{SAMP} = 22.3$  ksp/s),  $T_A = +25^\circ C$ .



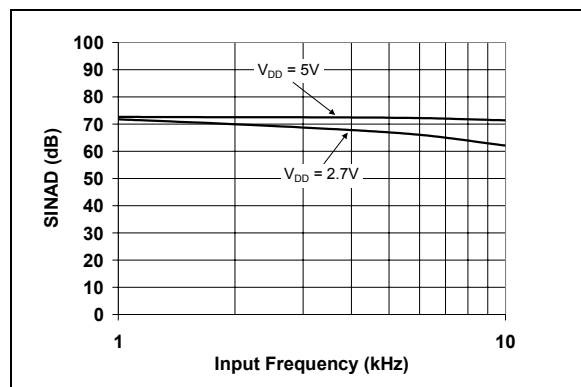
**FIGURE 2-19:** Gain Error vs. Temperature.



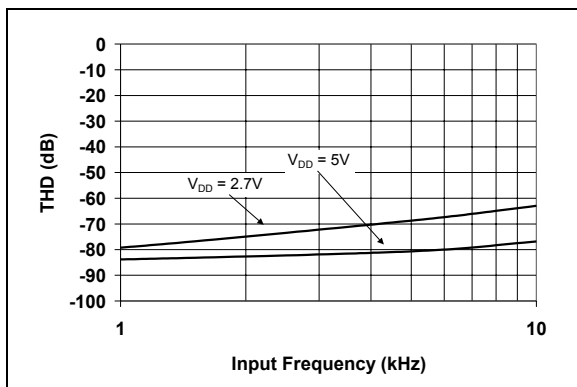
**FIGURE 2-22:** Offset Error vs. Temperature.



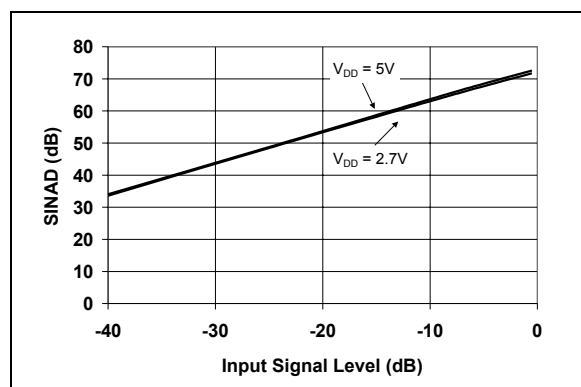
**FIGURE 2-20:** SNR vs. Input Frequency.



**FIGURE 2-23:** SINAD vs. Input Frequency.



**FIGURE 2-21:** THD vs. Input Frequency.

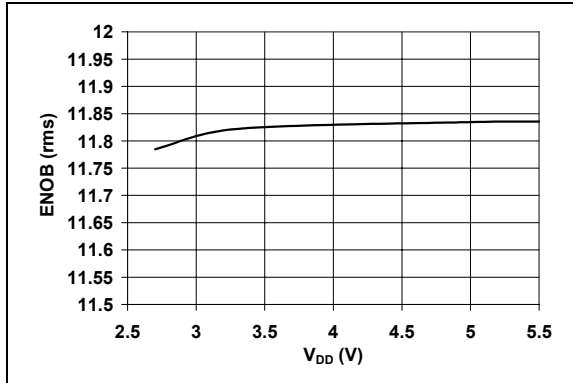


**FIGURE 2-24:** SINAD vs. Input Signal Level.

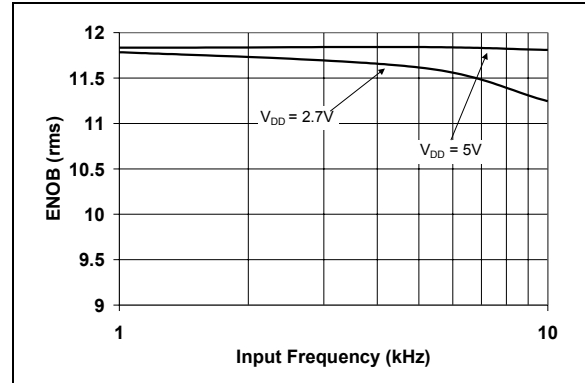


# MCP3221

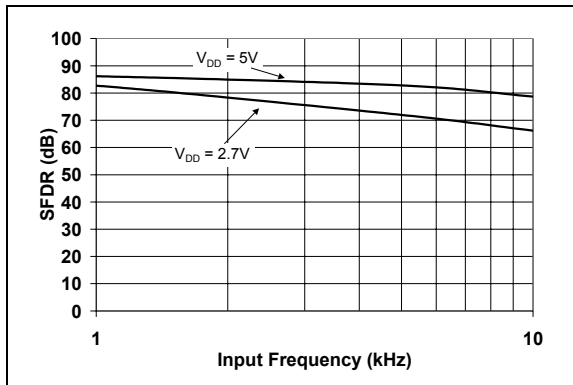
**Note:** Unless otherwise indicated,  $V_{DD} = 5V$ ,  $V_{SS} = 0V$ ,  $I^2C$  Fast Mode Timing (SCL = 400 kHz), Continuous Conversion Mode ( $f_{SAMP} = 22.3$  kps),  $T_A = +25^\circ C$ .



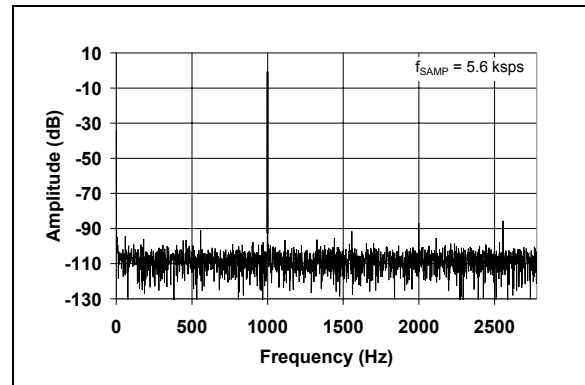
**FIGURE 2-25:** ENOB vs.  $V_{DD}$ .



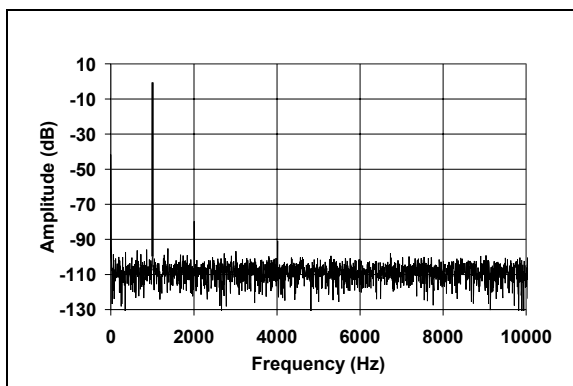
**FIGURE 2-28:** ENOB vs. Input Frequency.



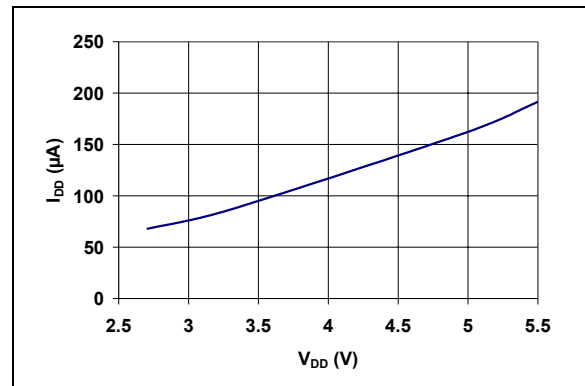
**FIGURE 2-26:** SFDR vs. Input Frequency.



**FIGURE 2-29:** Spectrum Using  $I^2C$ ™ Standard Mode (Representative Part, 1 kHz Input Frequency).



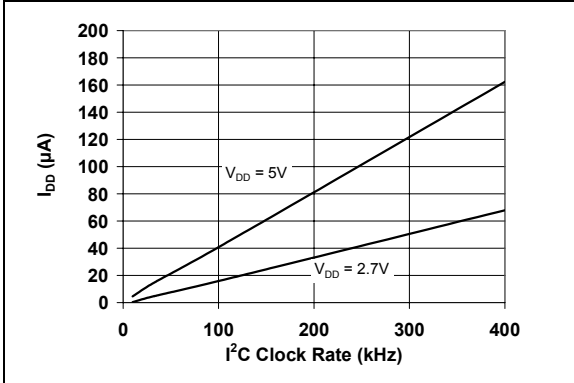
**FIGURE 2-27:** Spectrum Using  $I^2C$ ™ Fast Mode (Representative Part, 1 kHz Input Frequency).



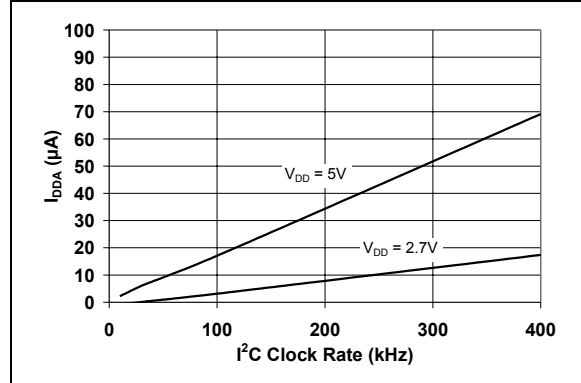
**FIGURE 2-30:**  $I_{DD}$  (Conversion) vs.  $V_{DD}$ .

# MCP3221

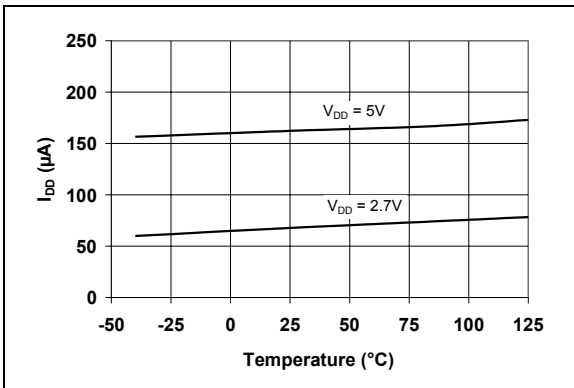
**Note:** Unless otherwise indicated,  $V_{DD} = 5V$ ,  $V_{SS} = 0V$ , I<sup>2</sup>C Fast Mode Timing (SCL = 400 kHz), Continuous Conversion Mode ( $f_{SAMP} = 22.3$  ksp/s),  $T_A = +25^\circ C$ .



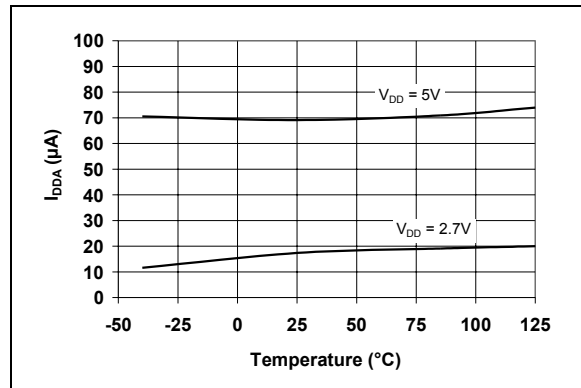
**FIGURE 2-31:**  $I_{DD}$  (Conversion) vs. Clock Rate.



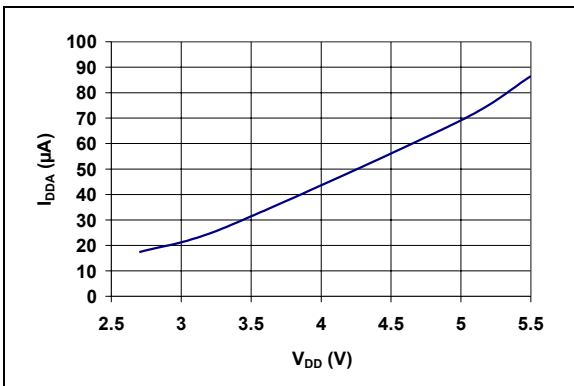
**FIGURE 2-34:**  $I_{DDA}$  (Active Bus) vs. Clock Rate.



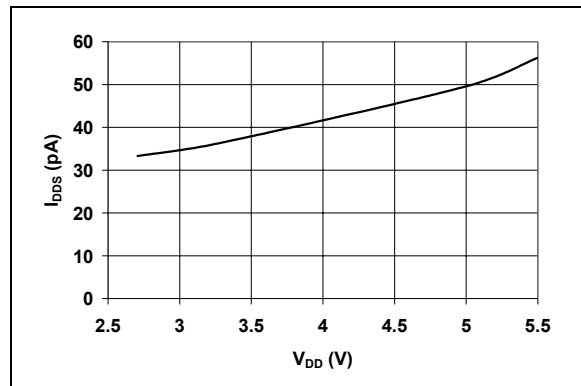
**FIGURE 2-32:**  $I_{DD}$  (Conversion) vs. Temperature.



**FIGURE 2-35:**  $I_{DDA}$  (Active Bus) vs. Temperature.



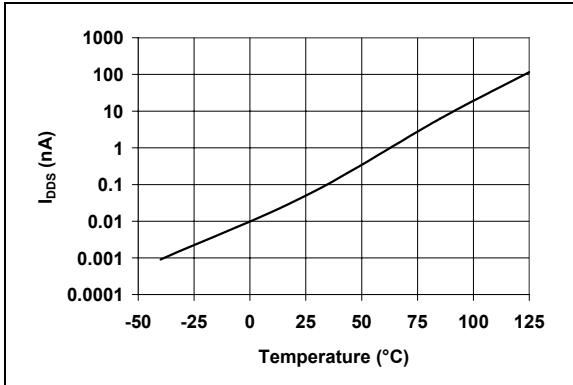
**FIGURE 2-33:**  $I_{DDA}$  (Active Bus) vs.  $V_{DD}$ .



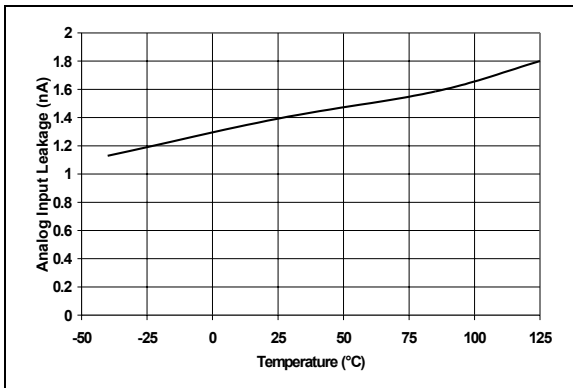
**FIGURE 2-36:**  $I_{DDs}$  (Standby) vs.  $V_{DD}$ .

# MCP3221

**Note:** Unless otherwise indicated,  $V_{DD} = 5V$ ,  $V_{SS} = 0V$ , I<sup>2</sup>C Fast Mode Timing (SCL = 400 kHz), Continuous Conversion Mode ( $f_{SAMP} = 22.3$  ksp/s),  $T_A = +25^{\circ}C$ .

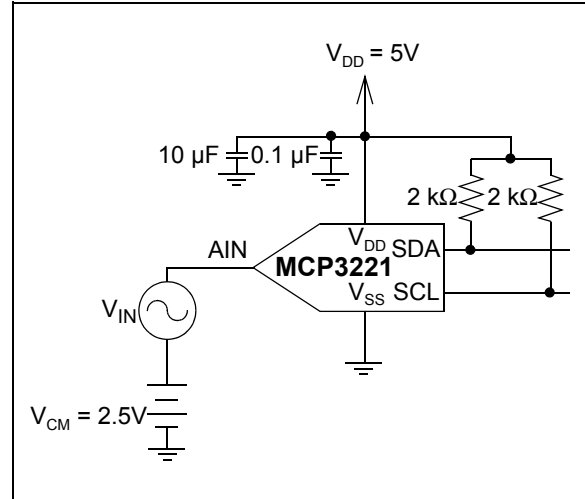


**FIGURE 2-37:**  $I_{DDs}$  (Standby) vs. Temperature.



**FIGURE 2-38:** Analog Input Leakage vs. Temperature.

## 2.1 Test Circuits



**FIGURE 2-39:** Typical Test Configuration.

# MCP3221

---

## 3.0 PIN FUNCTIONS

TABLE 3-1: PIN FUNCTION TABLE

Name	Function
$V_{DD}$	+2.7V to 5.5V Power Supply
$V_{SS}$	Ground
AIN	Analog Input
SDA	Serial Data In/Out
SCL	Serial Clock In

### 3.1 $V_{DD}$ and $V_{SS}$

The  $V_{DD}$  pin, with respect to  $V_{SS}$ , provides power to the device as well as a voltage reference for the conversion process. Refer to Section 6.4, "Device Power and Layout Considerations", for tips on power and grounding.

### 3.2 Analog Input (AIN)

AIN is the input pin to the sample-and-hold circuitry of the Successive Approximation Register (SAR) converter. Care should be taken in driving this pin. Refer to Section 6.1, "Driving the Analog Input". For proper conversions, the voltage on this pin can vary from  $V_{SS}$  to  $V_{DD}$ .

### 3.3 Serial Data (SDA)

SDA is a bidirectional pin used to transfer addresses and data into and out of the device. Since it is an open-drain terminal, the SDA bus requires a pull-up resistor to  $V_{DD}$  (typically 10 k $\Omega$  for 100 kHz and 2 k $\Omega$  for 400 kHz SCL clock speeds). Refer to Section 6.2, "Connecting to the I<sup>2</sup>C Bus", for more information.

For normal data transfer, SDA is allowed to change only during SCL low. Changes during SCL high are reserved for indicating the START and STOP conditions. Refer to Section 5.1, "I<sup>2</sup>C Bus Characteristics".

### 3.4 Serial Clock (SCL)

SCL is an input pin used to synchronize the data transfer to and from the device on the SDA pin and is an open-drain terminal. Therefore, the SCL bus requires a pull-up resistor to  $V_{DD}$  (typically 10 k $\Omega$  for 100 kHz and 2 k $\Omega$  for 400 kHz SCL clock speeds). Refer to Section 6.2, "Connecting to the I<sup>2</sup>C Bus".

For normal data transfer, SDA is allowed to change only during SCL low. Changes during SCL high are reserved for indicating the START and STOP conditions. Refer to Section 6.1, "Driving the Analog Input".

## 4.0 DEVICE OPERATION

The MCP3221 employs a classic SAR architecture. This architecture uses an internal sample and hold capacitor to store the analog input while the conversion is taking place. At the end of the acquisition time, the input switch of the converter opens and the device uses the collected charge on the internal sample-and-hold capacitor to produce a serial 12-bit digital output code. The acquisition time and conversion is self-timed using an internal clock. After each conversion, the results are stored in a 12-bit register that can be read at any time.

Communication with the device is accomplished with a 2-wire, I<sup>2</sup>C interface. Maximum sample rates of 22.3 ksp/s are possible with the MCP3221 in a continuous-conversion mode and an SCL clock rate of 400 kHz.

### 4.1 Digital Output Code

The digital output code produced by the MCP3221 is a function of the input signal and power supply voltage, V<sub>DD</sub>. As the V<sub>DD</sub> level is reduced, the LSB size is reduced accordingly. The theoretical LSB size is shown below.

#### EQUATION

$$LSB\ SIZE = \frac{V_{DD}}{4096}$$

V<sub>DD</sub> = Supply voltage

The output code of the MCP3221 is transmitted serially with MSB first. The format of the code is straight binary.

### 4.2 Conversion Time (t<sub>CONV</sub>)

The conversion time is the time required to obtain the digital result once the analog input is disconnected from the holding capacitor. With the MCP3221, the specified conversion time is typically 8.96 μs. This time is dependent on the internal oscillator and is independent of SCL.

### 4.3 Acquisition Time (t<sub>ACQ</sub>)

The acquisition time is the amount of time the sample cap array is acquiring charge.

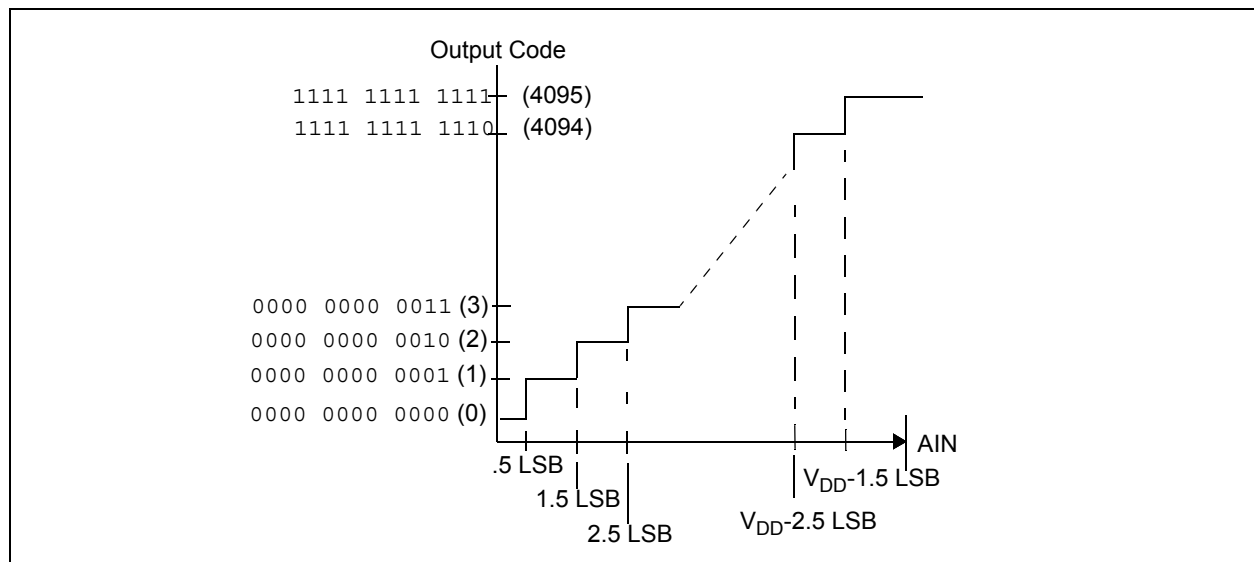
The acquisition time is, typically, 1.12 μs. This time is dependent on the internal oscillator and independent of SCL.

### 4.4 Sample Rate

Sample rate is the inverse of the maximum amount of time that is required from the point of acquisition of the first conversion to the point of acquisition of the second conversion.

The sample rate can be measured either by single or continuous conversions. A single conversion includes a Start Bit, Address Byte, Two Data Bytes and a Stop bit. This sample rate is measured from one Start Bit to the next Start Bit.

For continuous conversions (requested by the Master by issuing an acknowledge after a conversion), the maximum sample rate is measured from conversion to conversion or a total of 18 clocks (two data bytes and two Acknowledge bits). Refer to Section 5-2, "Device Addressing".



**FIGURE 4-1:** Transfer Function.

# MCP3221

---

## 4.5 Differential Non-Linearity (DNL)

In the ideal A/D converter transfer function, each code has a uniform width. That is, the difference in analog input voltage is constant from one code transition point to the next. Differential nonlinearity (DNL) specifies the deviation of any code in the transfer function from an ideal code width of 1 LSB. The DNL is determined by subtracting the locations of successive code transition points after compensating for any gain and offset errors. A positive DNL implies that a code is longer than the ideal code width, while a negative DNL implies that a code is shorter than the ideal width.

## 4.6 Integral Non-Linearity (INL)

Integral nonlinearity (INL) is a result of cumulative DNL errors and specifies how much the overall transfer function deviates from a linear response. The method of measurement used in the MCP3221 A/D converter to determine INL is the “end-point” method.

## 4.7 Offset Error

Offset error is defined as a deviation of the code transition points that are present across all output codes. This has the effect of shifting the entire A/D transfer function. The offset error is measured by finding the difference between the actual location of the first code transition and the desired location of the first transition. The ideal location of the first code transition is located at 1/2 LSB above  $V_{SS}$ .

## 4.8 Gain Error

The gain error determines the amount of deviation from the ideal slope of the A/D converter transfer function. Before the gain error is determined, the offset error is measured and subtracted from the conversion result. The gain error can then be determined by finding the location of the last code transition and comparing that location to the ideal location. The ideal location of the last code transition is 1.5 LSBs below full-scale or  $V_{DD}$ .

## 4.9 Conversion Current ( $I_{DD}$ )

The average amount of current over the time required to perform a 12-bit conversion.

## 4.10 Active Bus Current ( $I_{DDA}$ )

The average amount of current over the time required to monitor the I<sup>2</sup>C bus. Any current the device consumes while it is not being addressed is referred to as “Active Bus” current.

## 4.11 Standby Current ( $I_{DDs}$ )

The average amount of current required while no conversion is occurring and while no data is being output (i.e., SCL and SDA lines are quiet).

## 4.12 I<sup>2</sup>C Standard Mode Timing

I<sup>2</sup>C specification where the frequency of SCL is 100 kHz.

## 4.13 I<sup>2</sup>C Fast Mode Timing

I<sup>2</sup>C specification where the frequency of SCL is 400 kHz.

---

## 5.0 SERIAL COMMUNICATIONS

### 5.1 I<sup>2</sup>C Bus Characteristics

The following bus protocol has been defined:

- Data transfer may be initiated only when the bus is not busy.
- During data transfer, the data line must remain stable whenever the clock line is high. Changes in the data line while the clock line is high will be interpreted as a START or STOP condition.

Accordingly, the following bus conditions have been defined (refer to Figure 5-1).

#### 5.1.1 BUS NOT BUSY (A)

Both data and clock lines remain high.

#### 5.1.2 START DATA TRANSFER (B)

A high-to-low transition of the SDA line while the clock (SCL) is high determines a START condition. All commands must be preceded by a START condition.

#### 5.1.3 STOP DATA TRANSFER (C)

A low-to-high transition of the SDA line while the clock (SCL) is high determines a STOP condition. All operations must be ended with a STOP condition.

#### 5.1.4 DATA VALID (D)

The state of the data line represents valid data when, after a START condition, the data line is stable for the duration of the clock signal's high period.

The data on the line must be changed during the low period of the clock signal. There is one clock pulse per bit of data.

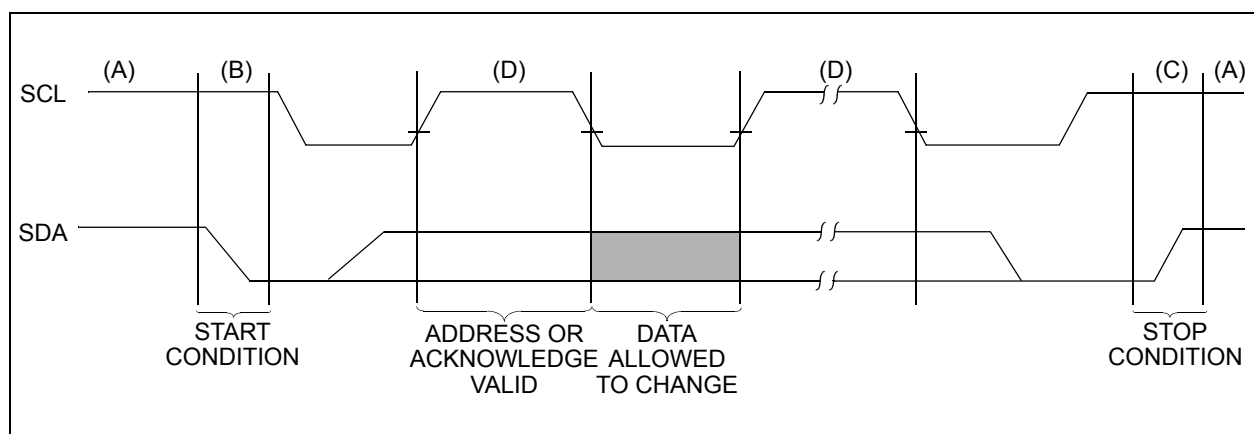
Each data transfer is initiated with a START condition and terminated with a STOP condition. The number of data bytes transferred between the START and STOP conditions is determined by the master device and is unlimited.

#### 5.1.5 ACKNOWLEDGE

Each receiving device, when addressed, is obliged to generate an acknowledge bit after the reception of each byte. The master device must generate an extra clock pulse which is associated with this acknowledge bit.

The device that acknowledges has to pull down the SDA line during the acknowledge clock pulse in such a way that the SDA line is stable-low during the high period of the acknowledge-related clock pulse. Setup and hold times must be taken into account. During reads, a master device must signal an end of data to the slave by not generating an acknowledge bit on the last byte that has been clocked out of the slave (NAK). In this case, the slave (MCP3221) will release the bus to allow the master device to generate the STOP condition.

The MCP3221 supports a bidirectional, 2-wire bus and data transmission protocol. The device that sends data onto the bus is the transmitter and the device receiving data is the receiver. The bus has to be controlled by a master device which generates the serial clock (SCL), controls the bus access and generates the START and STOP conditions, while the MCP3221 works as a slave device. Both master and slave devices can operate as either transmitter or receiver, but the master device determines which mode is activated.



**FIGURE 5-1:** Data Transfer Sequence on the Serial Bus.

# MCP3221

## 5.2 Device Addressing

The address byte is the first byte received following the START condition from the master device. The first part of the control byte consists of a 4-bit device code, which is set to 1010 for the MCP3221. The device code is followed by three address bits: A2, A1 and A0. The default address bits are 1001. Contact the Microchip factory for additional address bit options. The address bits allow up to eight MCP3221 devices on the same bus and are used to determine which device is accessed.

The eighth bit of the slave address determines if the master device wants to read conversion data or write to the MCP3221. When set to a '1', a read operation is selected. When set to a '0', a write operation is selected. There are no writable registers on the MCP3221. Therefore, this bit must be set to a '1' in order to initiate a conversion.

The MCP3221 is a slave device that is compatible with the I<sup>2</sup>C 2-wire serial interface protocol. A hardware connection diagram is shown in Figure 6-2. Communication is initiated by the microcontroller (master device), which sends a START bit followed by the address byte.

On completion of the conversion(s) performed by the MCP3221, the microcontroller must send a STOP bit to end communication.

The last bit in the device address byte is the R/W bit. When this bit is a logic '1', a conversion will be executed. Setting this bit to logic '0' will also result in an "acknowledge" (ACK) from the MCP3221, with the device then releasing the bus. This can be used for device polling. Refer to Section 6.3, "Device Polling", for more information.

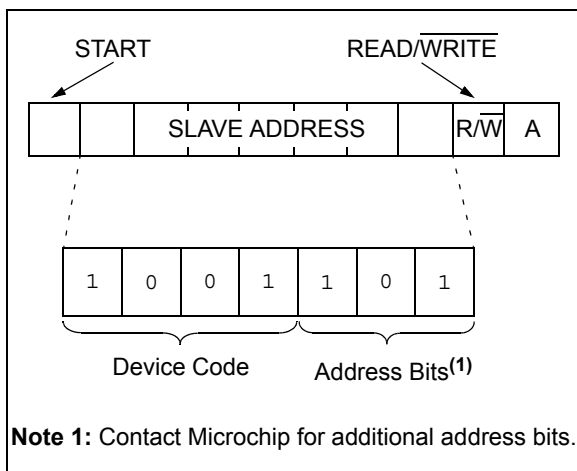


FIGURE 5-2: Device Addressing.

## 5.3 Executing a Conversion

This section will describe the details of communicating with the MCP3221 device. Initiating the sample-and-hold acquisition, reading the conversion data and executing multiple conversions will be discussed.

### 5.3.1 INITIATING THE SAMPLE AND HOLD

The acquisition and conversion of the input signal begins with the falling edge of the R/W bit of the address byte. At this point, the internal clock initiates the sample, hold and conversion cycle, all of which are internal to the ADC.

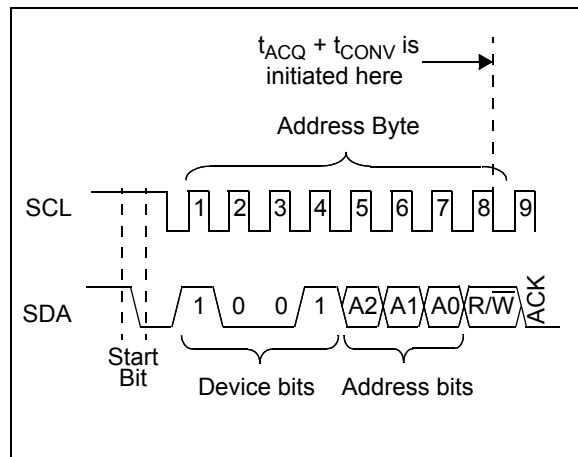


FIGURE 5-3: Initiating the Conversion, Address Byte.

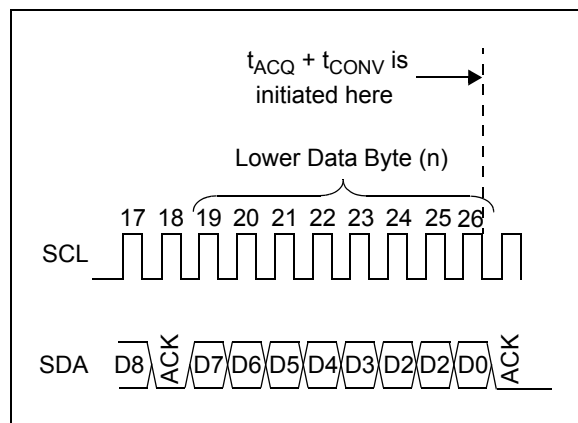


FIGURE 5-4: Initiating the Conversion, Continuous Conversions.



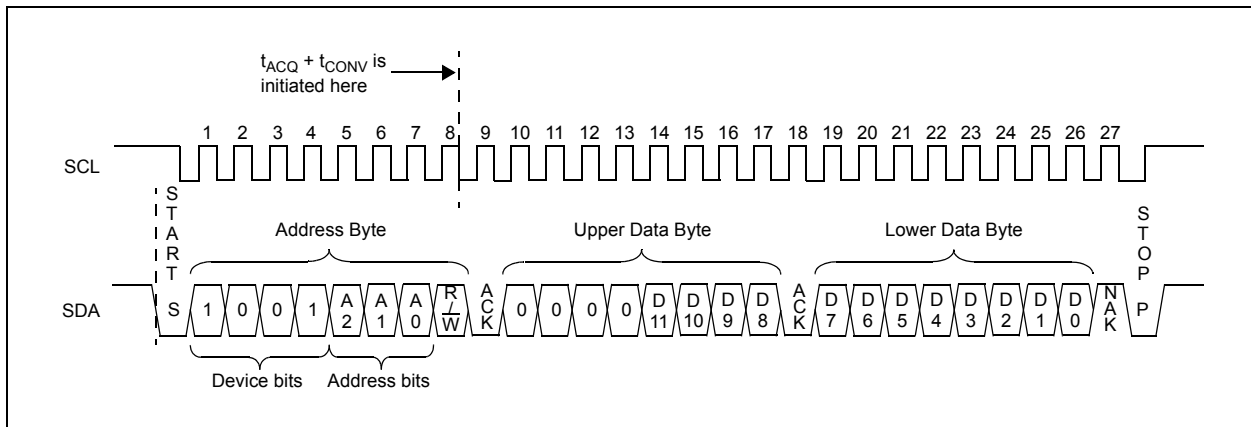
# MCP3221

The input signal will initially be sampled with the first falling edge of the clock following the transmission of a logic-high R/W bit. Additionally, with the rising edge of the SCL, the ADC will transmit an acknowledge bit (ACK = 0). The master must release the data bus during this clock pulse to allow the MCP3221 to pull the line low (refer to Figure 5-3).

For consecutive samples, sampling begins on the falling edge of the LSB of the conversion result, which is two bytes long. Refer to Figure 5-6 a for timing diagram.

## 5.3.2 READING THE CONVERSION DATA

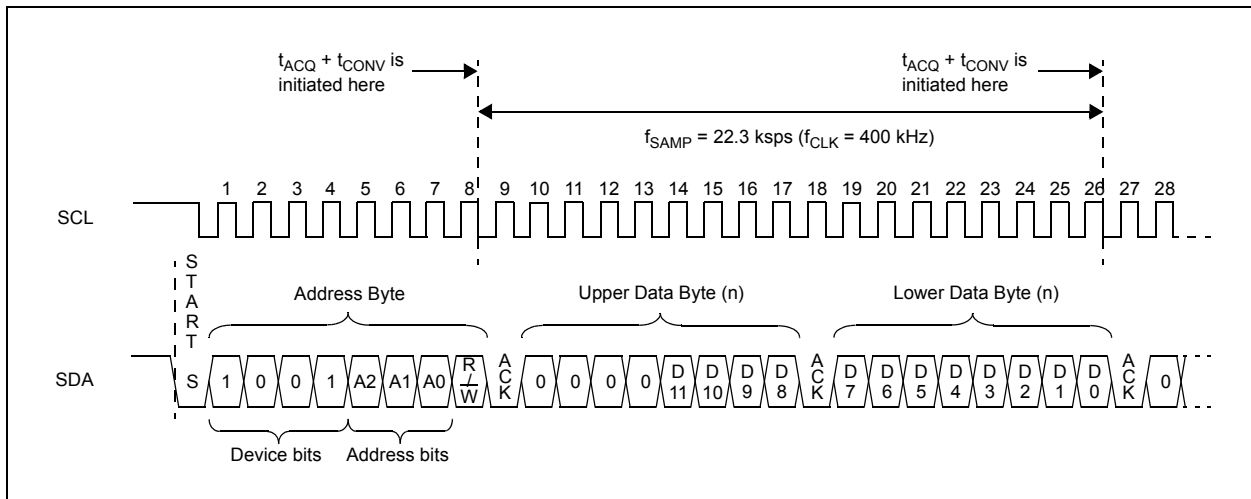
Once the MCP3221 acknowledges the address byte, the device will transmit four '0' bits followed by the upper four data bits of the conversion. The master device will then acknowledge this byte with an ACK = Low. With the following 8 clock pulses, the MCP3221 will transmit the lower eight data bits from the conversion. The master then sends an ACK = high, indicating to the MCP3221 that no more data is requested. The master can then send a stop bit to end the transmission.



**FIGURE 5-5:** Executing a Conversion.

## 5.3.3 CONSECUTIVE CONVERSIONS

For consecutive samples, sampling begins on the falling edge of the LSB of the conversion result. See Figure 5-6 for timing.



**FIGURE 5-6:** Continuous Conversion.

# MCP3221

## 6.0 APPLICATIONS INFORMATION

### 6.1 Driving the Analog Input

The MCP3221 has a single-ended analog input (AIN). For proper conversion results, the voltage at the AIN pin must be kept between  $V_{SS}$  and  $V_{DD}$ . If the converter has no offset error, gain error, INL or DNL errors, and the voltage level of AIN is equal to or less than  $V_{SS} + 1/2 \text{ LSB}$ , the resultant code will be 000h. Additionally, if the voltage at AIN is equal to or greater than  $V_{DD} - 1.5 \text{ LSB}$ , the output code will be FFfh.

The analog input model is shown in Figure 6-1. In this diagram, the source impedance ( $R_{SS}$ ) adds to the internal sampling switch ( $R_S$ ) impedance, directly affecting the time required to charge the capacitor ( $C_{SAMPLE}$ ). Consequently, a larger source impedance increases the offset error, gain error and integral linearity errors of the conversion. Ideally, the impedance of the signal source should be near zero. This is achievable with an operational amplifier, such as the MCP6022, which has a closed-loop output impedance of tens of ohms.

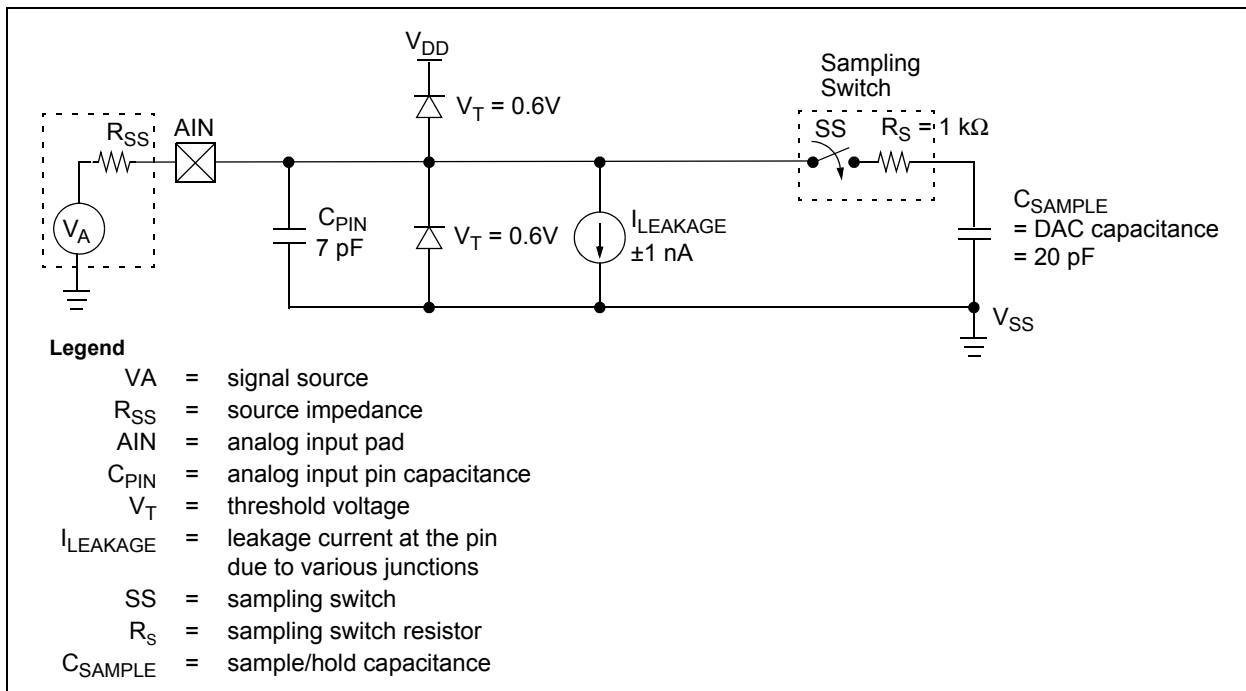


FIGURE 6-1: Analog Input Model, AIN.

### 6.2 Connecting to the I<sup>2</sup>C Bus

The I<sup>2</sup>C bus is an open-collector bus, requiring pull-up resistors connected to the SDA and SCL lines. This configuration is shown in Figure 6-2.

The number of devices connected to the bus is limited only by the maximum bus capacitance of 400 pF. A possible configuration using multiple devices is shown in Figure 6-3.

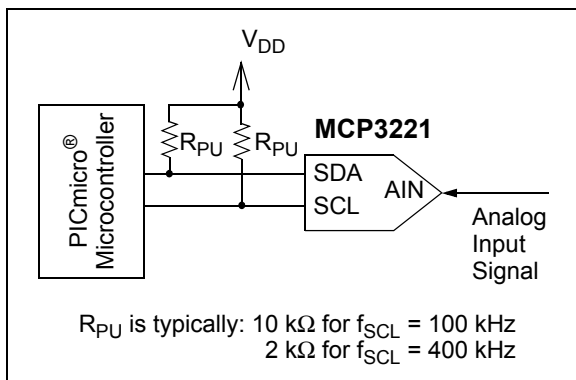


FIGURE 6-2: Pull-up Resistors on I<sup>2</sup>C Bus.

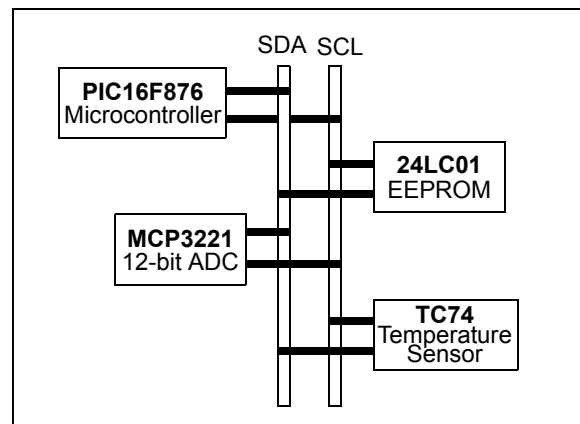
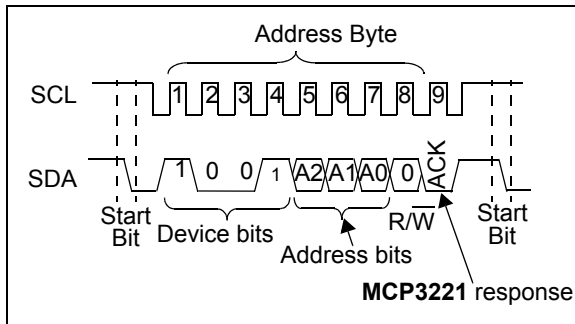


FIGURE 6-3: Multiple Devices on I<sup>2</sup>C™ Bus.

## 6.3 Device Polling

In some instances, it may be necessary to test for MCP3221 presence on the I<sup>2</sup>C bus without performing a conversion. This operation is described in Figure 6-4. Here we are setting the R/W bit in the address byte to a zero. The MCP3221 will then acknowledge by pulling SDA low during the ACK clock and then release the bus back to the I<sup>2</sup>C master. A stop or repeated start bit can then be issued from the master and I<sup>2</sup>C communication can continue.

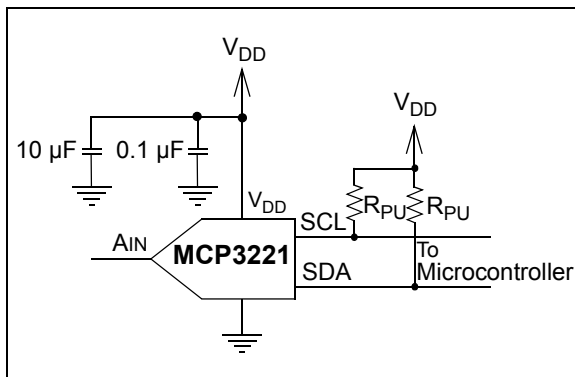


**FIGURE 6-4:** Device Polling.

## 6.4 Device Power and Layout Considerations

### 6.4.1 POWERING THE MCP3221

V<sub>DD</sub> supplies the power to the device as well as the reference voltage. A bypass capacitor value of 0.1 μF is recommended. Adding a 10 μF capacitor in parallel is recommended to attenuate higher frequency noise present in some systems.



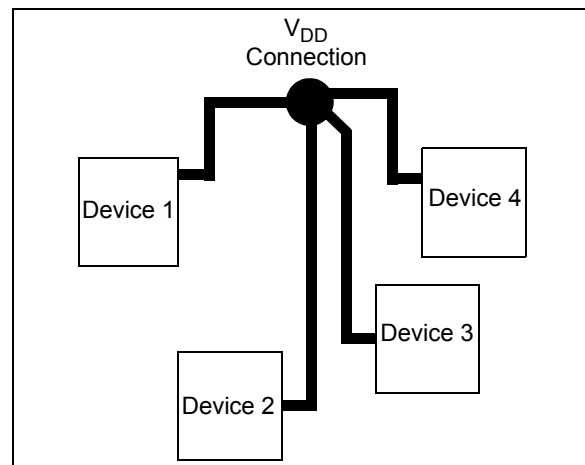
**FIGURE 6-5:** Powering the MCP3221.

### 6.4.2 LAYOUT CONSIDERATIONS

When laying out a printed circuit board for use with analog components, care should be taken to reduce noise wherever possible. A bypass capacitor from V<sub>DD</sub> to ground should always be used with this device and should be placed as close as possible to the device pin. A bypass capacitor value of 0.1 μF is recommended.

Digital and analog traces should be separated as much as possible on the board, with no traces running underneath the device or the bypass capacitor. Extra precautions should be taken to keep traces with high-frequency signals (such as clock lines) as far as possible from analog traces.

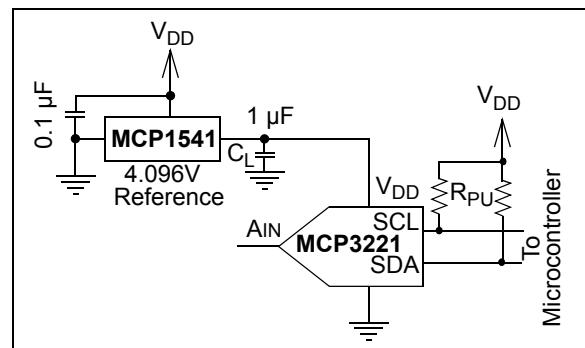
Use of an analog ground plane is recommended in order to keep the ground potential the same for all devices on the board. Providing V<sub>DD</sub> connections to devices in a “star” configuration can also reduce noise by eliminating current return paths and associated errors (Figure 6-6). For more information on layout tips when using the MCP3221 or other ADC devices, refer to AN688, “Layout Tips for 12-Bit A/D Converter Applications”.



**FIGURE 6-6:** V<sub>DD</sub> traces arranged in a “Star” configuration in order to reduce errors caused by current return paths.

### 6.4.3 USING A REFERENCE FOR SUPPLY

The MCP3221 uses V<sub>DD</sub> as both power and a reference. In some applications, it may be necessary to use a stable reference to achieve the required accuracy. Figure 6-7 shows an example using the MCP1541 as a 4.096V, 2% reference.



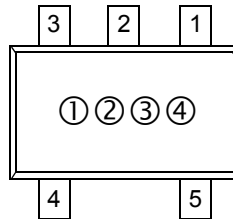
**FIGURE 6-7:** Stable Power and Reference Configuration.

# MCP3221

## 7.0 PACKAGING INFORMATION

### 7.1 Package Marking Information

#### 5-Pin SOT-23A (EIAJ SC-74) Device



Part Number	Address Option	SOT-23
MCP3221A0T-I/OT	000	EE
MCP3221A1T-I/OT	001	EH
MCP3221A2T-I/OT	010	EB
MCP3221A3T-I/OT	011	EC
MCP3221A4T-I/OT	100	ED
MCP3221A5T-I/OT	101	S1 *
MCP3221A6T-I/OT	110	EF
MCP3221A7T-I/OT	111	EG

MCP3221A0T-E/OT	000	GE
MCP3221A1T-E/OT	001	GH
MCP3221A2T-E/OT	010	GB
MCP3221A3T-E/OT	011	GC
MCP3221A4T-E/OT	100	GD
MCP3221A5T-E/OT	101	GA *
MCP3221A6T-E/OT	110	GF
MCP3221A7T-E/OT	111	GG

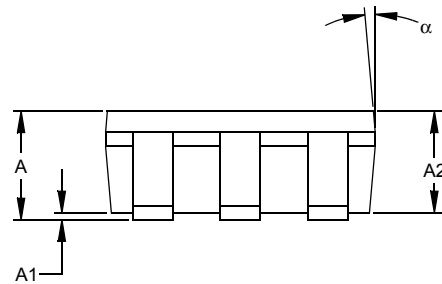
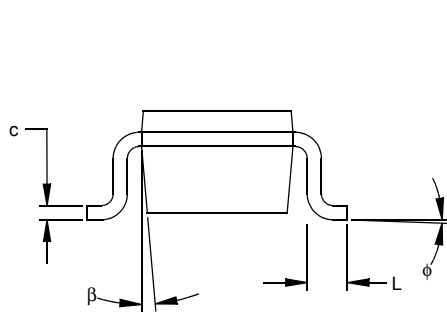
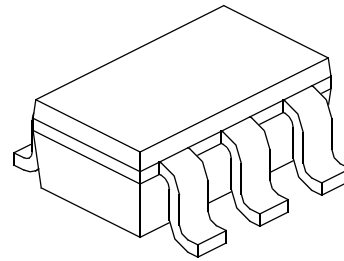
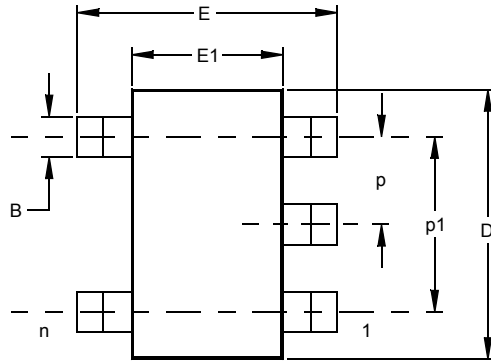
\* Default option. Contact Microchip Factory for other address options.

<b>Legend:</b>	1	Part Number code + temperature range
	2	Part Number code + temperature range
	3	Year and work week
	4	Lot ID
<b>Note:</b>	In the event the full Microchip part number cannot be marked on one line, it will be carried over to the next line thus limiting the number of available characters for customer specific information.	

\* Standard device marking consists of Microchip part number, year code, week code, and traceability code.

# MCP3221

## 5-Lead Plastic Small Outline Transistor (OT) (SOT23)



Units		INCHES*			MILLIMETERS		
Dimension	Limits	MIN	NOM	MAX	MIN	NOM	MAX
Number of Pins	n		5			5	
Pitch	p		.038			0.95	
Outside lead pitch (basic)	p1		.075			1.90	
Overall Height	A	.035	.046	.057	0.90	1.18	1.45
Molded Package Thickness	A2	.035	.043	.051	0.90	1.10	1.30
Standoff §	A1	.000	.003	.006	0.00	0.08	0.15
Overall Width	E	.102	.110	.118	2.60	2.80	3.00
Molded Package Width	E1	.059	.064	.069	1.50	1.63	1.75
Overall Length	D	.110	.116	.122	2.80	2.95	3.10
Foot Length	L	.014	.018	.022	0.35	0.45	0.55
Foot Angle	$\phi$	0	5	10	0	5	10
Lead Thickness	c	.004	.006	.008	0.09	0.15	0.20
Lead Width	B	.014	.017	.020	0.35	0.43	0.50
Mold Draft Angle Top	$\alpha$	0	5	10	0	5	10
Mold Draft Angle Bottom	$\beta$	0	5	10	0	5	10

\* Controlling Parameter  
 § Significant Characteristic

Notes:

Dimensions D and E1 do not include mold flash or protrusions. Mold flash or protrusions shall not exceed .010" (0.254mm) per side.

JEDEC Equivalent: MO-178

Drawing No. C04-091

# MCP3221

---

NOTES:

# MCP3221

## PRODUCT IDENTIFICATION SYSTEM

To order or obtain information, e.g., on pricing or delivery, refer to the factory or the listed sales office.

<u>PART NO.</u>	<u>XX</u>	<u>X</u>	<u>/XX</u>
Device	Address Options	Temperature Range	Package
Device:	MCP3221T: 12-Bit 2-Wire Serial A/D Converter (Tape and Reel)		
Temperature Range:	I = -40°C to +85°C E = -40°C to +125°C		
Address Options:	<u>XX</u>	<u>A2</u>	<u>A1</u> <u>A0</u>
	A0 =	0	0 0
	A1 =	0	0 1
	A2 =	0	1 0
	A3 =	0	1 1
	A4 =	1	0 0
	A5 * =	1	0 1
	A6 =	1	1 0
	A7 =	1	1 1
	* Default option. Contact Microchip factory for other address options		
Package:	OT = SOT-23, 5-lead (Tape and Reel)		
<b>Examples:</b>	a) MCP3221A0T-I/OT: Industrial, A0 Address, Tape and Reel b) MCP3221A1T-I/OT: Industrial, A1 Address, Tape and Reel c) MCP3221A2T-I/OT: Industrial, A2 Address, Tape and Reel d) MCP3221A3T-I/OT: Industrial, A3 Address, Tape and Reel e) MCP3221A4T-I/OT: Industrial, A4 Address, Tape and Reel f) MCP3221A5T-I/OT: Industrial, A5 Address, Tape and Reel g) MCP3221A6T-I/OT: Industrial, A6 Address, Tape and Reel h) MCP3221A7T-I/OT: Industrial, A7 Address, Tape and Reel a) MCP3221A0T-E/OT: Extended, A0 Address, Tape and Reel b) MCP3221A1T-E/OT: Extended, A1 Address, Tape and Reel c) MCP3221A2T-E/OT: Extended, A2 Address, Tape and Reel d) MCP3221A3T-E/OT: Extended, A3 Address, Tape and Reel e) MCP3221A4T-E/OT: Extended, A4 Address, Tape and Reel f) MCP3221A5T-E/OT: Extended, A5 Address, Tape and Reel g) MCP3221A6T-E/OT: Extended, A6 Address, Tape and Reel h) MCP3221A7T-IE/OT: Extended, A7 Address, Tape and Reel		

## Sales and Support

### Data Sheets

Products supported by a preliminary Data Sheet may have an errata sheet describing minor operational differences and recommended workarounds. To determine if an errata sheet exists for a particular device, please contact one of the following:

1. Your local Microchip sales office
2. The Microchip Corporate Literature Center U.S. FAX: (480) 792-7277
3. The Microchip Worldwide Site ([www.microchip.com](http://www.microchip.com))

Please specify which device, revision of silicon and Data Sheet (include Literature #) you are using.

### Customer Notification System

Register on our web site ([www.microchip.com/cn](http://www.microchip.com/cn)) to receive the most current information on our products.

# MCP3221

---

NOTES:



---

---

**Note the following details of the code protection feature on Microchip devices:**

- Microchip products meet the specification contained in their particular Microchip Data Sheet.
- Microchip believes that its family of products is one of the most secure families of its kind on the market today, when used in the intended manner and under normal conditions.
- There are dishonest and possibly illegal methods used to breach the code protection feature. All of these methods, to our knowledge, require using the Microchip products in a manner outside the operating specifications contained in Microchip's Data Sheets. Most likely, the person doing so is engaged in theft of intellectual property.
- Microchip is willing to work with the customer who is concerned about the integrity of their code.
- Neither Microchip nor any other semiconductor manufacturer can guarantee the security of their code. Code protection does not mean that we are guaranteeing the product as "unbreakable."

Code protection is constantly evolving. We at Microchip are committed to continuously improving the code protection features of our products. Attempts to break microchip's code protection feature may be a violation of the Digital Millennium Copyright Act. If such acts allow unauthorized access to your software or other copyrighted work, you may have a right to sue for relief under that Act.

---

Information contained in this publication regarding device applications and the like is intended through suggestion only and may be superseded by updates. It is your responsibility to ensure that your application meets with your specifications. No representation or warranty is given and no liability is assumed by Microchip Technology Incorporated with respect to the accuracy or use of such information, or infringement of patents or other intellectual property rights arising from such use or otherwise. Use of Microchip's products as critical components in life support systems is not authorized except with express written approval by Microchip. No licenses are conveyed, implicitly or otherwise, under any intellectual property rights.

**Trademarks**

The Microchip name and logo, the Microchip logo, dsPIC, KEELOQ, MPLAB, PIC, PICmicro, PICSTART, PRO MATE and PowerSmart are registered trademarks of Microchip Technology Incorporated in the U.S.A. and other countries.


FilterLab, microID, MXDEV, MXLAB, PICMASTER, SEEVAL and The Embedded Control Solutions Company are registered trademarks of Microchip Technology Incorporated in the U.S.A.

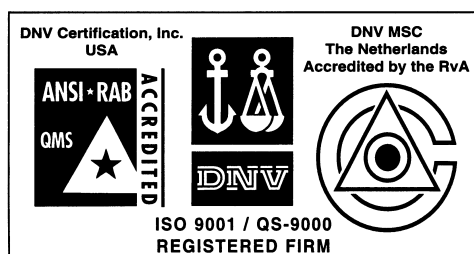
Accuron, Application Maestro, dsPICDEM, dsPICDEM.net, ECONOMONITOR, FanSense, FlexROM, fuzzyLAB, In-Circuit Serial Programming, ICSP, ICEPIC, microPort, Migratable Memory, MPASM, MPLIB, MPLINK, MPSIM, PICC, PICKit, PICDEM, PICDEM.net, PowerCal, PowerInfo, PowerMate, PowerTool, rLAB, rPIC, Select Mode, SmartSensor, SmartShunt, SmartTel and Total Endurance are trademarks of Microchip Technology Incorporated in the U.S.A. and other countries.

Serialized Quick Turn Programming (SQTP) is a service mark of Microchip Technology Incorporated in the U.S.A.

All other trademarks mentioned herein are property of their respective companies.

© 2003, Microchip Technology Incorporated, Printed in the U.S.A., All Rights Reserved.

 Printed on recycled paper.



*Microchip received QS-9000 quality system certification for its worldwide headquarters, design and wafer fabrication facilities in Chandler and Tempe, Arizona in July 1999 and Mountain View, California in March 2002. The Company's quality system processes and procedures are QS-9000 compliant for its PICmicro® 8-bit MCUs, KEELOQ® code hopping devices, Serial EEPROMs, microperipherals, non-volatile memory and analog products. In addition, Microchip's quality system for the design and manufacture of development systems is ISO 9001 certified.*

---

---



## WORLDWIDE SALES AND SERVICE

### AMERICAS

#### Corporate Office

2355 West Chandler Blvd.  
Chandler, AZ 85224-6199  
Tel: 480-792-7200 Fax: 480-792-7277  
Technical Support: 480-792-7627  
Web Address: <http://www.microchip.com>

#### Atlanta

3780 Mansell Road, Suite 130  
Alpharetta, GA 30022  
Tel: 770-640-0034 Fax: 770-640-0307

#### Boston

2 Lan Drive, Suite 120  
Westford, MA 01886  
Tel: 978-692-3848 Fax: 978-692-3821

#### Chicago

333 Pierce Road, Suite 180  
Itasca, IL 60143  
Tel: 630-285-0071 Fax: 630-285-0075

#### Dallas

4570 Westgrove Drive, Suite 160  
Addison, TX 75001  
Tel: 972-818-7423 Fax: 972-818-2924

#### Detroit

Tri-Atria Office Building  
32255 Northwestern Highway, Suite 190  
Farmington Hills, MI 48334  
Tel: 248-538-2250 Fax: 248-538-2260

#### Kokomo

2767 S. Albright Road  
Kokomo, IN 46902  
Tel: 765-864-8360 Fax: 765-864-8387

#### Los Angeles

18201 Von Karman, Suite 1090  
Irvine, CA 92612  
Tel: 949-263-1888 Fax: 949-263-1338

#### Phoenix

2355 West Chandler Blvd.  
Chandler, AZ 85224-6199  
Tel: 480-792-7966 Fax: 480-792-4338

#### San Jose

Microchip Technology Inc.  
2107 North First Street, Suite 590  
San Jose, CA 95131  
Tel: 408-436-7950 Fax: 408-436-7955

#### Toronto

6285 Northam Drive, Suite 108  
Mississauga, Ontario L4V 1X5, Canada  
Tel: 905-673-0699 Fax: 905-673-6509

### ASIA/PACIFIC

#### Australia

Microchip Technology Australia Pty Ltd  
Marketing Support Division  
Suite 22, 41 Rawson Street  
Epping 2121, NSW  
Australia  
Tel: 61-2-9868-6733 Fax: 61-2-9868-6755

#### China - Beijing

Microchip Technology Consulting (Shanghai)  
Co., Ltd., Beijing Liaison Office  
Unit 915  
Bei Hai Wan Tai Bldg.  
No. 6 Chaoyangmen Beidajie  
Beijing, 100027, No. China  
Tel: 86-10-85282100 Fax: 86-10-85282104

#### China - Chengdu

Microchip Technology Consulting (Shanghai)  
Co., Ltd., Chengdu Liaison Office  
Rm. 2401-2402, 24th Floor,  
Ming Xing Financial Tower  
No. 88 TIDU Street  
Chengdu 610016, China  
Tel: 86-28-86766200 Fax: 86-28-86766599

#### China - Fuzhou

Microchip Technology Consulting (Shanghai)  
Co., Ltd., Fuzhou Liaison Office  
Unit 28F, World Trade Plaza  
No. 71 Wusi Road  
Fuzhou 350001, China  
Tel: 86-591-7503506 Fax: 86-591-7503521

#### China - Hong Kong SAR

Microchip Technology Hongkong Ltd.  
Unit 901-6, Tower 2, Metroplaza  
223 Hing Fong Road  
Kwai Fong, N.T., Hong Kong  
Tel: 852-2401-1200 Fax: 852-2401-3431

#### China - Shanghai

Microchip Technology Consulting (Shanghai)  
Co., Ltd.  
Room 701, Bldg. B  
Far East International Plaza  
No. 317 Xian Xia Road  
Shanghai, 200051  
Tel: 86-21-6275-5700 Fax: 86-21-6275-5060

#### China - Shenzhen

Microchip Technology Consulting (Shanghai)  
Co., Ltd., Shenzhen Liaison Office  
Rm. 1812, 18/F, Building A, United Plaza  
No. 5022 Binhe Road, Futian District  
Shenzhen 518033, China  
Tel: 86-755-82901380 Fax: 86-755-8295-1393

#### China - Qingdao

Rm. B505A, Fullhope Plaza,  
No. 12 Hong Kong Central Rd.  
Qingdao 266071, China  
Tel: 86-532-5027355 Fax: 86-532-5027205

#### India

Microchip Technology Inc.  
India Liaison Office  
Marketing Support Division  
Divyasree Chambers  
1 Floor, Wing A (A3/A4)  
No. 11, O'Shaughnessy Road  
Bangalore, 560 025, India  
Tel: 91-80-2290061 Fax: 91-80-2290062

### Japan

Microchip Technology Japan K.K.  
Benex S-1 6F  
3-18-20, Shinyokohama  
Kohoku-Ku, Yokohama-shi  
Kanagawa, 222-0033, Japan  
Tel: 81-45-471-6166 Fax: 81-45-471-6122

### Korea

Microchip Technology Korea  
168-1, Youngbo Bldg. 3 Floor  
Samsung-Dong, Kangnam-Ku  
Seoul, Korea 135-882  
Tel: 82-2-554-7200 Fax: 82-2-558-5934

### Singapore

Microchip Technology Singapore Pte Ltd.  
200 Middle Road  
#07-02 Prime Centre  
Singapore, 188980  
Tel: 65-6334-8870 Fax: 65-6334-8850

### Taiwan

Microchip Technology (Barbados) Inc.,  
Taiwan Branch  
11F-3, No. 207  
Tung Hua North Road  
Taipei, 105, Taiwan  
Tel: 886-2-2717-7175 Fax: 886-2-2545-0139

### EUROPE

#### Austria

Microchip Technology Austria GmbH  
Durisolstrasse 2  
A-4600 Wels  
Austria  
Tel: 43-7242-2244-399  
Fax: 43-7242-2244-393

#### Denmark

Microchip Technology Nordic ApS  
Regus Business Centre  
Lautrup høj 1-3  
Ballerup DK-2750 Denmark  
Tel: 45-4420-9895 Fax: 45-4420-9910

#### France

Microchip Technology SARL  
Parc d'Activite du Moulin de Massy  
43 Rue du Saule Trapu  
Batiment A - 1er Etage  
91300 Massy, France  
Tel: 33-1-69-53-63-20 Fax: 33-1-69-30-90-79

#### Germany

Microchip Technology GmbH  
Steinheilstrasse 10  
D-85737 Ismaning, Germany  
Tel: 49-89-627-144-0  
Fax: 49-89-627-144-44

#### Italy

Microchip Technology SRL  
Via Quasimodo, 12  
20025 Legnano (MI)  
Milan, Italy  
Tel: 39-0331-742611 Fax: 39-0331-466781

#### United Kingdom

Microchip Ltd.  
505 Eskdale Road  
Winnersh Triangle  
Wokingham  
Berkshire, England RG41 5TU  
Tel: 44-118-921-5869 Fax: 44-118-921-5820

This datasheet has been download from:

[www.datasheetcatalog.com](http://www.datasheetcatalog.com)

Datasheets for electronics components.