

SONY®

CXA1198AP

Stereo Cassette Deck Recording Equalizer

Description

CXA1198AP is a bipolar IC developed for recording equalizers used in analog cassette decks. A built-in filter circuit dispenses with external parts such as the inductor (coil).

External resistors permit the independent setting of the six parameters required for the recording equalizer.

Features

- Inductor (coil) no use
- 6 parameters for recording equalizer: gain, peaking frequency, Q, peak gain, medium band equalizing gain and medium band equalizing frequency can be independently set using resistors.
- 2 built-in channels
- Compact package (16 pin DIP)

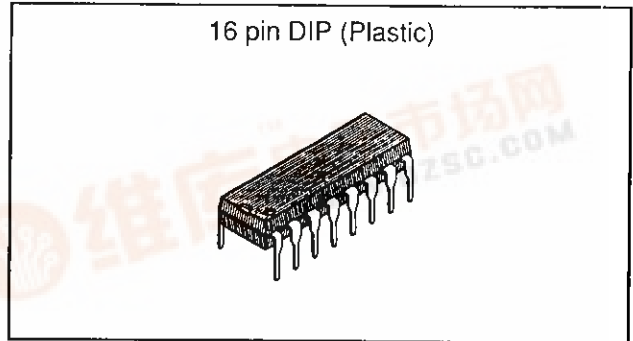

Structure

Bipolar silicon monolithic IC

Applications

- Recording equalizer amplifier for analog cassette decks.

Absolute Maximum Ratings (Ta=25°C)

| | | | |
|-------------------------------|------------------|-------------|----|
| • Supply voltage | V _{CC} | 17 | V |
| • Storage temperature | T _{stg} | -55 to +150 | °C |
| • Operating temperature | T _{opr} | -20 to +75 | °C |
| • Allowable power dissipation | P _D | 900 | mW |

Recommended Operating Conditions (Ta=25°C)

| | | | |
|------------------|-----------------------------------|--------------|-----------------|
| • Supply voltage | V _{CC} , V _{EE} | ±4.0 to ±7.5 | V |
| | | | (Dual supply) |
| | V _{CC} | 8.0 to 15.0 | V |
| | | | (Single supply) |

Block Diagram and Pin Configuration (Top View)

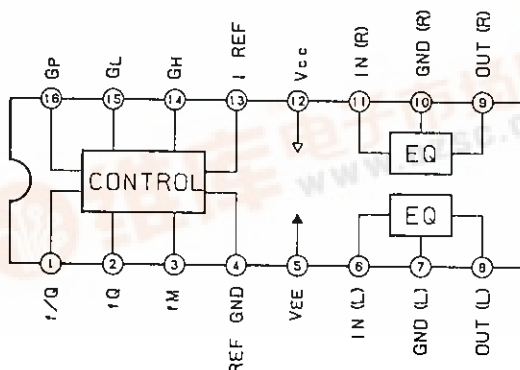

Pin Description and Equivalent Circuit

Ta=25°C, Vcc=7.0V, VEE=-7.0V, no signal

| No. | Symbol | DC voltage | Equivalent circuit | Description |
|-------------------------------------|-------------------------------------------|------------|--------------------|-----------------------------------------------------------------------------------------------------------------------------------------------------|
| 1 2 3 13 14 15 16 | f/Q fQ fM IREF GH GH GP | 1.2V | | <p>Current input pin that sets respective parameters.</p> <p>Attaching a resistor to GND generates the current that sets respective parameters.</p> |
| 4 | REF GND | GND | | <p>Dual supply : GND Single supply : GND</p> |
| 5 | VEE | -7.0V | | <p>Dual supply : VEE Single supply : GND</p> |
| 6 11 | IN (L) IN (R) | 0V | | <p>Input pin Input impedance : 100kΩ</p> |
| 7 10 | GND (L) GND (R) | 0V | | <p>Dual supply : GND Single supply : $\frac{V_{cc}}{2}$</p> |
| 8 9 | OUT (L) OUT (R) | 0.5V | | <p>Output pin</p> |
| 12 | Vcc | 7.0V | | <p>Power supply pin : Vcc</p> |

Electrical Characteristics

Ta=25°C, Vcc=7.0V, VEE=-7.0V

| Item | Symbol | Condition | Min. | Typ. | Max. | Unit |
|--------------------------------|----------|-------------------------|-------|-------|-------|------|
| Current consumption | Icc | | 11.0 | 17.5 | 26.0 | mA |
| Reference input level | VIN | | -28.0 | -26.0 | -24.0 | dBm |
| Reference output level | VOUT | | - | -5.0 | - | dBm |
| S/N ratio | SN(AWTG) | Rg=5kΩ, "A" -WTG filter | 60 | 63 | - | dB |
| Signal handling | SH | RL=3.6kΩ, 1kHz, THD=1% | 17.0 | 18.5 | - | dB |
| Total harmonic distortion rate | THD | 1kHz, 0dB | - | 0.2 | 0.5 | % |
| Output offset voltage | VOFF | | -0.5 | 0.5 | 1.0 | V |

Variable Width of Respective Parameters

| Item | Symbol | Condition | Min. | Typ. | Max. | Unit |
|-------------------------------------|--------|-----------|------|------|------|------|
| fM medium band correction frequency | fM | | 0.63 | 2.0 | 6.3 | kHz |
| fo peaking frequency | fo | | 10 | 20 | 40 | kHz |
| Peaking Q | Q | | 2 | 4 | 6 | |
| GL low band gain | GL | | -3.0 | 0.0 | 5.0 | dB |
| GH medium band gain | GH | | -8.0 | 0.0 | 12.0 | dB |
| GP peaking gain | GP | | 5.0 | 15.0 | 25.0 | dB |

Setting Error of Respective Parameters

| Item | Symbol | Condition | Min. | Typ. | Max. | Unit |
|-------------------------------------|--------|---------------|------|------|------|------|
| fM medium band correction frequency | ΔfM | | -10 | 0 | 10 | % |
| fo peaking frequency | Δfo | | -10 | 0 | 10 | % |
| Peaking Q | ΔQ | | -5 | 0 | 5 | % |
| GL low band gain | ΔGL | Setting error | -0.5 | 0 | 0.5 | dB |
| GH medium band gain | ΔGH | refer to GL | -0.8 | 0 | 0.8 | dB |
| GP peaking gain | ΔGP | refer to GL | -1.2 | 0 | 1.2 | dB |
| Input impedance | ZIN | Pin 6, Pin 11 | 65 | 100 | 150 | kΩ |

Note) Unless otherwise specified, settings for GL, GH, GP, FM, FP, and Q are characteristics provided when the typical value is set.

Electrical Characteristics Test Circuit

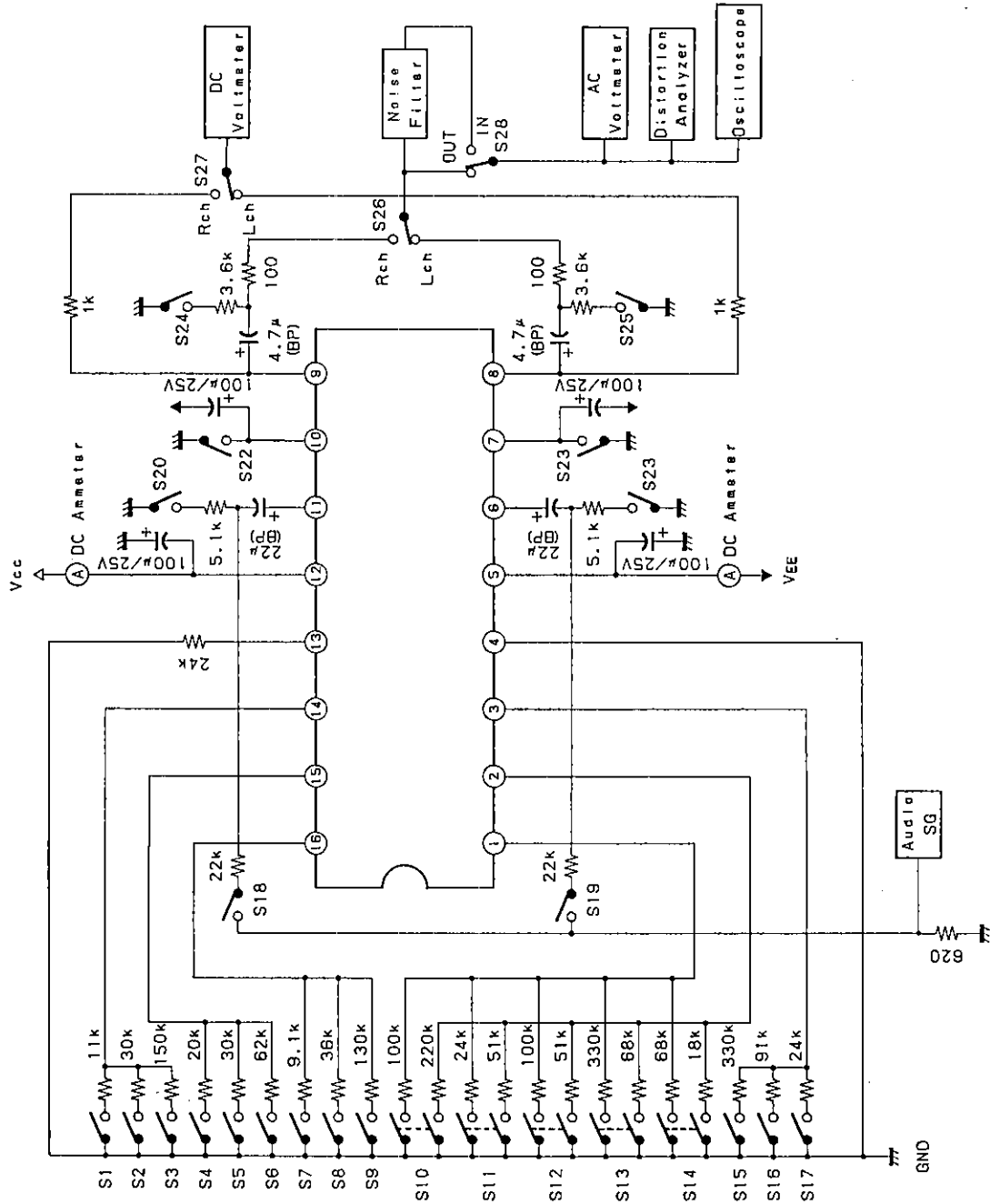

Parameters Characteristics vs. Respective Resistance

R_{GL} vs. G_L (gain) characteristics (refer to $R_{GL}=30\text{ k}\Omega$) R_{GH} vs. G_H (gain) characteristics (refer to G_L)

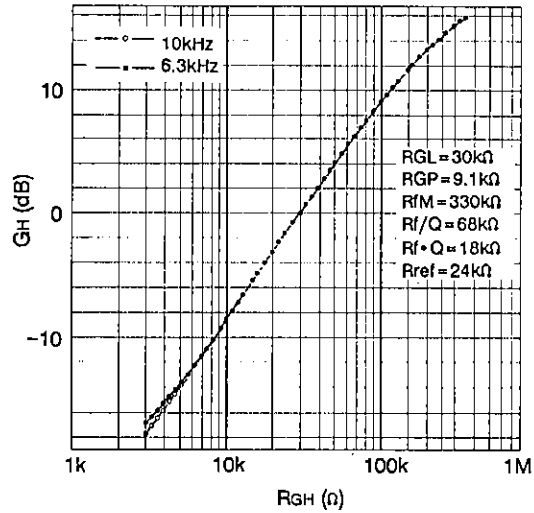
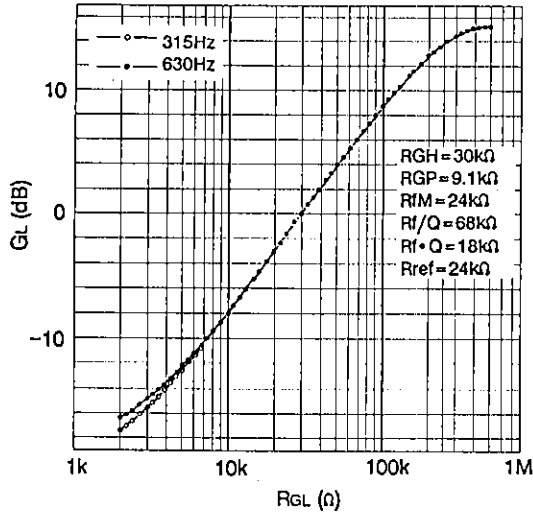

R_{GP} vs. G_P (gain) characteristics (refer to G_L)

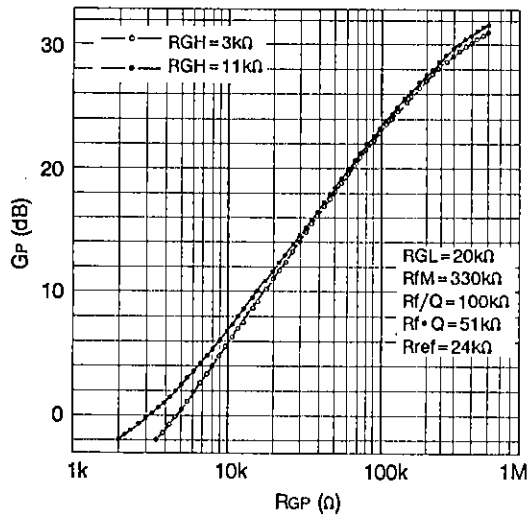

R_{fM} vs. f_M (cut off frequency) characteristics

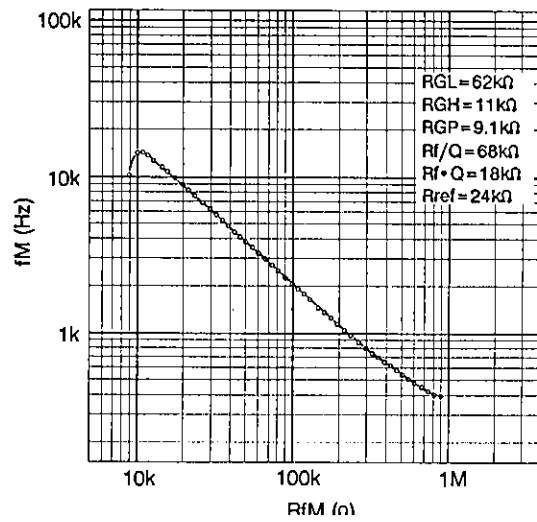

R_f/Q vs. f/Q (cut off frequency) characteristics

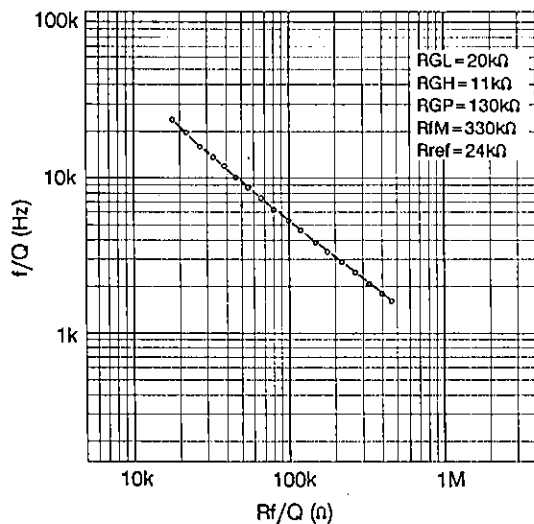

$R_f \cdot Q$ vs. $f \cdot Q$ (cut off frequency) characteristics

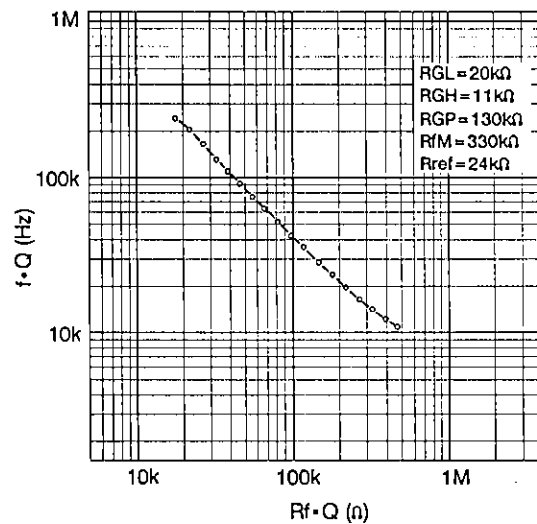

Electrical Characteristics

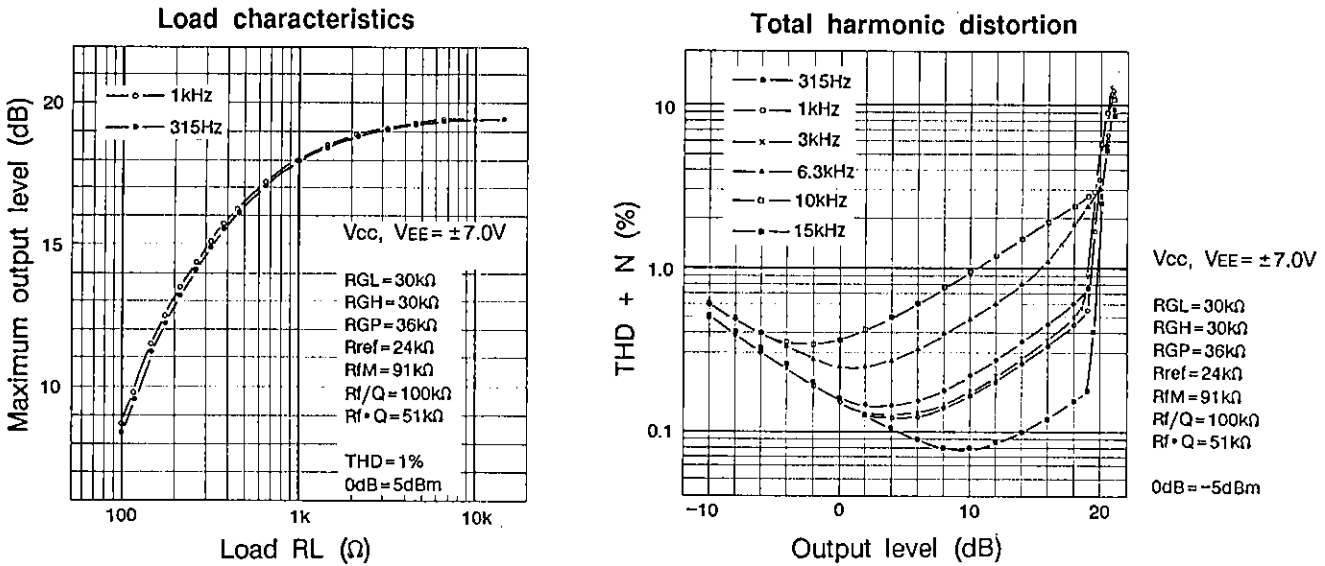

Operation

CXA1198AP obtains the frequency characteristics necessary for the recording equalizer by means of the circuit block shown in Fig. 1.

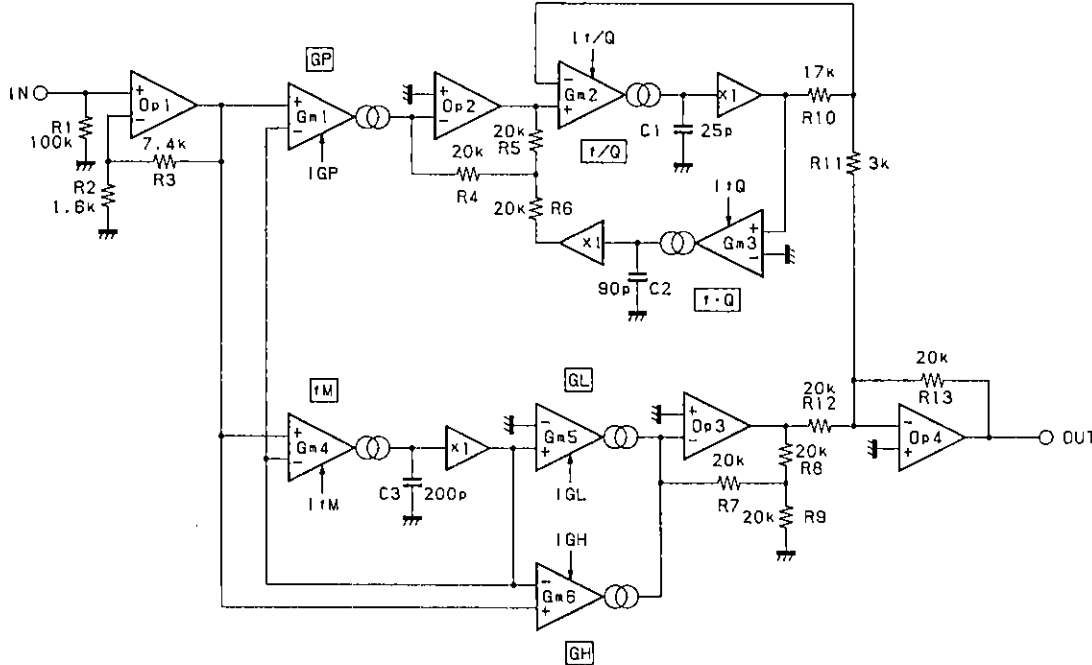

Fig. 1

G_{m1} through G_{m6} in the figure are transconductance amplifiers and $Op1$ through $Op4$ are operational amplifiers.

Transconductance amplifiers change voltage into current conversion coefficient using control currents (I_{GL} , I_{GH} , I_{GP} , I_{FM} , $I_{F/Q}$, $I_{f \cdot Q}$). When a capacitor is connected to the load, those transconductance amplifiers turn into variable integrators. When a resistor is connected to the load they become variable gain amplifiers.

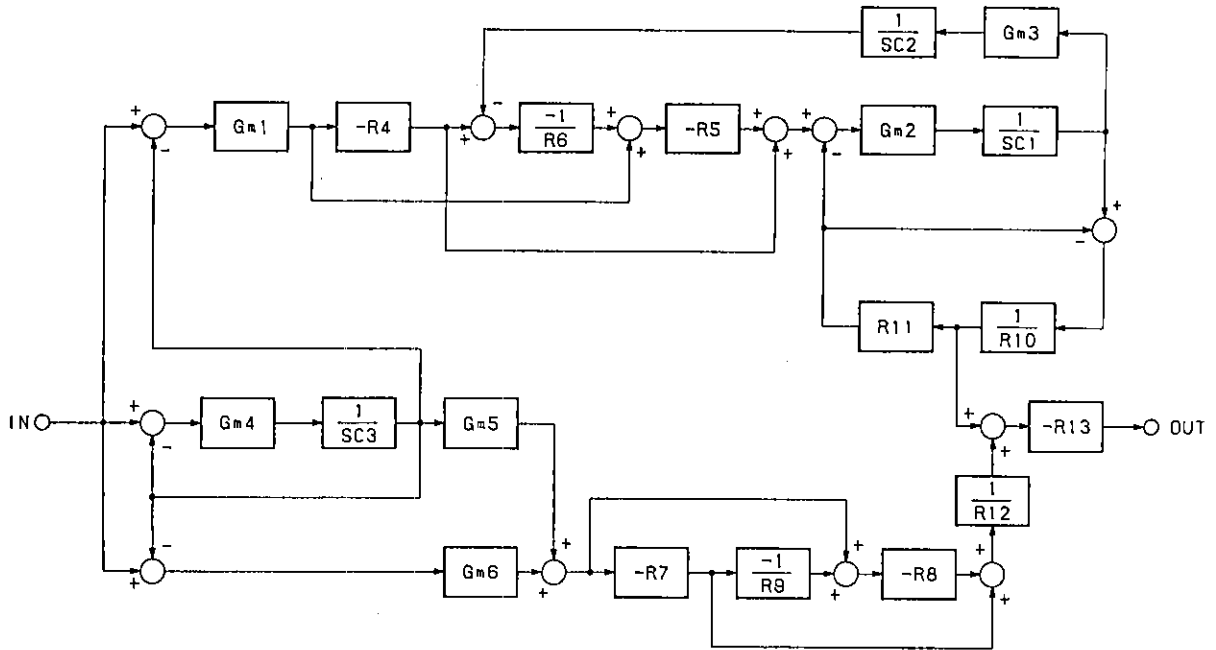

Fig. 2 Signal block diagram

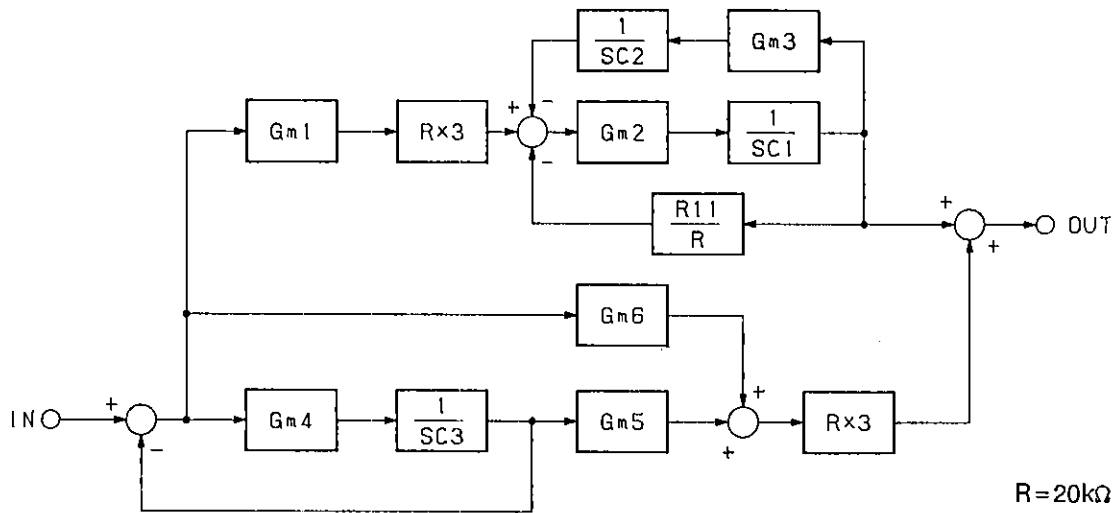

Fig. 3 Signal block diagram (simplified of Fig. 2)

The transfer function is as follows for the recording equalizer circuit.

When the block diagram in Fig. 3 is divided to low pass filter, high pass filter, and band pass filter and respective transfer function are GLPF (S), GHPF (S), and GBPF (S):

$$GLPF(S) = \frac{\frac{Gm4}{C3}}{S + \frac{Gm4}{C3}} \cdot 3 \cdot R \cdot Gm5 \dots\dots\dots(1)$$

$$GHPF(S) = \frac{S}{S + \frac{Gm4}{C3}} \cdot 3 \cdot R \cdot Gm6 \dots\dots\dots(2)$$

$$GBPF = \frac{\frac{R}{R11} \cdot S \cdot \frac{Gm2}{C1} \cdot \frac{R11}{R}}{S^2 + S \cdot \frac{Gm2}{C1} \cdot \frac{R11}{R} + \frac{Gm2 \cdot Gm3}{C1 \cdot C2}} \cdot \frac{S}{S + \frac{Gm4}{C3}} \cdot 3 \cdot R \cdot Gm1 \dots\dots(3)$$

From (1), (2) and (3), transfer function GEQ(S) of the recording equalizer circuit becomes:

$$GEQ(S) = GLPF(S) + GHPF(S) + GBOF(S) \dots\dots\dots(4)$$

From (4):

$$GEQ(S) = \frac{S^3 \cdot e + S^2 \cdot f + S \cdot g + h}{S^3 \cdot a + S^2 \cdot B + S \cdot c + d}$$

- a = C1 · C2 · C3 · R
- b = C2 · (C3 · R11 · Gm2 · + G · R · Gm4)
- c = Gm2 · (C3 · R · Gm3 + C2 · R11 · Gm4)
- d = R · Gm2 · Gm3 · Gm4
- e = C1 · C2 · C3 · 3 · R² · Gm6
- f = C2 · (C3 · R11 · Gm2 · Gm6 + C1 · R · Gm4 · Gm6 + C3 · R · Gm1 · Gm2) · 3 · R
- g = Gm2 · (C3 · R · Gm3 · Gm6 + C2 · R11 · Gm4 · Gm5 + C2 · R · Gm1 · Gm4) · 3 · R
- h = 3 · R · Gm2 · Gm3 · Gm4 · Gm5

From GEQ(S) above:

- By changing Gm4, medium band correction frequency fm can be changed.
- By changing Gm5, low band gain GL can be changed.
- By changing Gm6, medium band gain GH can be changed.
- By changing Gm1, peaking gain GP can be changed.
- By changing Gm2, the relation Fo/Q between the peaking frequency and Q can be changed.
- By changing Gm3, the relation Fo·Q between the peaking frequency and Q can be changed.

As explained above, CXA1198AP can set at will the six parameters: low band gain, peaking frequency, Q, peaking gain, medium band equalizing gain, and medium band equalizing frequency, necessary for the recording equalizer.

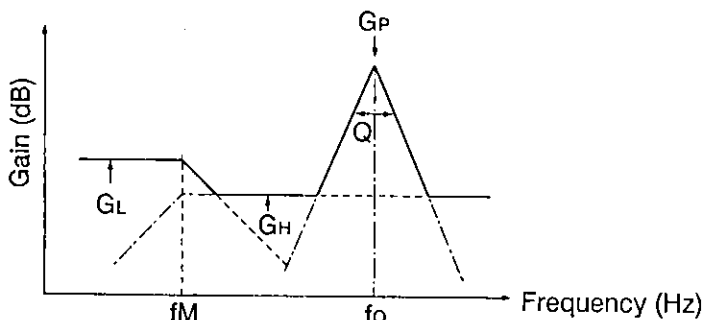

Fig. 4 - 8 -

Configuration of the transconductance amplifier as follows: Fig. 5 shows the basic circuit of the transconductor amplifier.

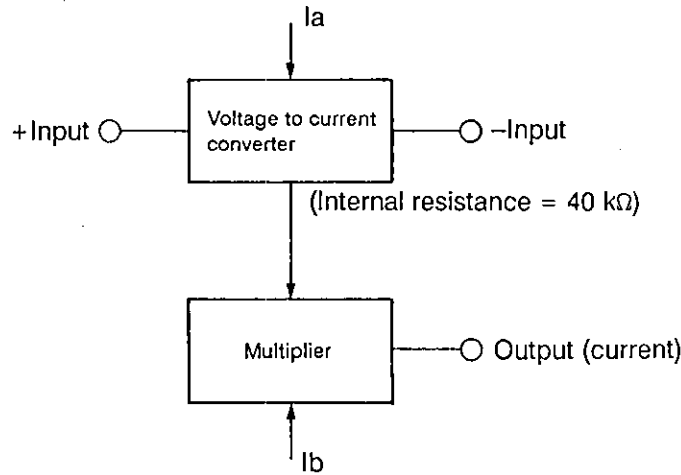

Fig. 5

The variable integrator composed of Gm2, Gm3 and Gm4, uses the referenced voltage generated inside the IC. Using voltage Ia provided by the internal diffused resistor and current Ib provided by the external resistor, the multiplier changes the voltage into current conversion coefficient.

The ratio of these two currents; Ia and Ib, reflects the irregularity of the diffused resistor. As the voltage into current converter is formed by of the internal diffused resistor, it is changed by the absolute value and temperature characteristics of the resistance. However, should the formation comprise Ia internally and Ib externally, the absolute value and temperature characteristics are not any more affected by the diffused resistor.

The variable gain amplifier composed of Gm1, Gm5 and Gm6 uses an internal diffused resistor. Setting Ia through an external resistor eliminates dependence on the diffused resistor.

Application Note

1. Power supply

CXA1198AP can be used with either dual supply, or single supply. Respective connections are shown below.

| | Vcc pin 12 | VEE pin 5 | GND pin 7,10 | REF GND pin 4 |
|---------------|------------|-----------|--------------|---------------|
| Dual supply | Vcc | VEE | GND | GND *1 |
| Single supply | Vcc | GND | —*2 | GND *1 |

Note) *1. Connect to the position where each parameter setting resistor is connected. Do the same with the resistor to be connected to pin 13 IREF. (See Mode control 3.)

*2. Connect the decoupling capacitor (100 μF or more) to pins 7 and 10 GND during single supply.

2. Low band equalizing

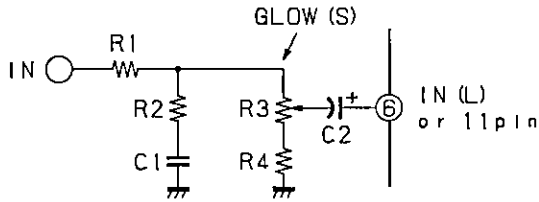

As shown in Fig. 6, connecting the time constant circuit of CR to input pins 6 and 11 makes low band correction possible. Transfer function GLOW(S) in Fig. 6 goes:

Fig. 6

$$GLOW(S) = \frac{(R1 + R4) \cdot (S \cdot C1 \cdot R2 + 1)}{S \cdot C1 \{R1 \cdot R2 + R1 \cdot (R3 + R4) + R2 \cdot (R3 + R4)\} + \{R1 + (R3 + R4)\}}$$

Where: C2 is large enough as the DC cutting capacitor, while the synthetic impedance is sufficiently smaller than the IC input impedance.

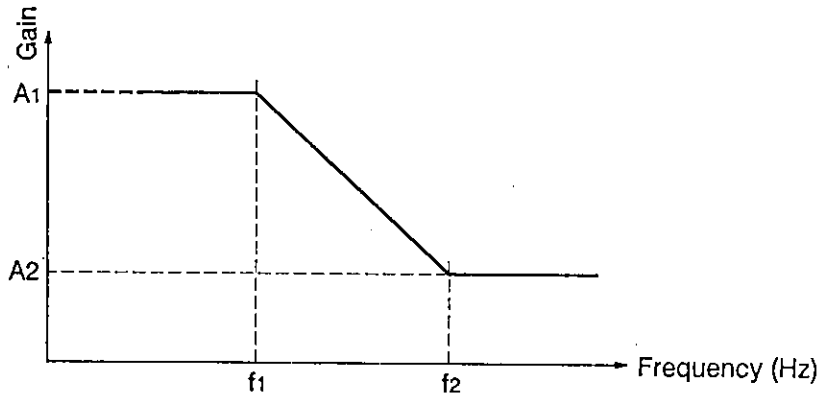

Fig. 7

Accordingly: f1, f2, A1 and A2 in Fig. 7 submit to the following.

$$f1 = \frac{R1 + (R3 + R4)}{2\pi \cdot C1 \{R1 \cdot R2 + R1 \cdot (R3 + R4) + R2 \cdot (R3 + R4)\}}$$

$$f2 = \frac{1}{2\pi \cdot C1 \cdot R2}$$

$$A1 = \frac{R3 + R4}{R1 + (R3 + R4)}$$

$$A2 = \frac{R2 \cdot (R3 + R4)}{R1 \cdot R2 + R1 \cdot (R3 + R4) + R2 \cdot (R3 + R4)}$$

3. Mode control

For mode control with manual switch, see the application circuit diagram (for Dual and single supply).

When the set is fitted with an auto tape selector and tape mode is logically run, use the same GND for both the common pin of the analog switch IC (Analog switch connection point) and the 24 kΩ resistor that is connected to pins 4 (REF GND) and 13 (IREF) of CXA1198AP.

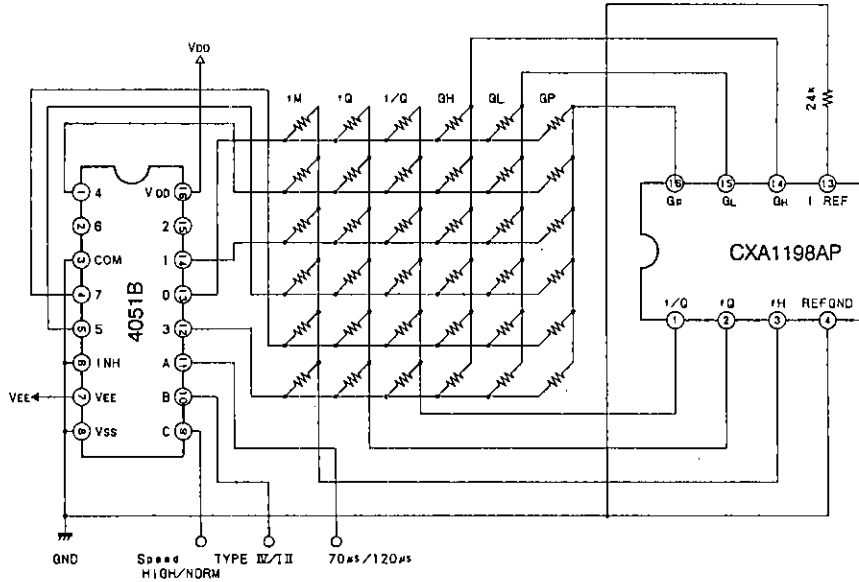

Fig. 8 (a) Dual supplies

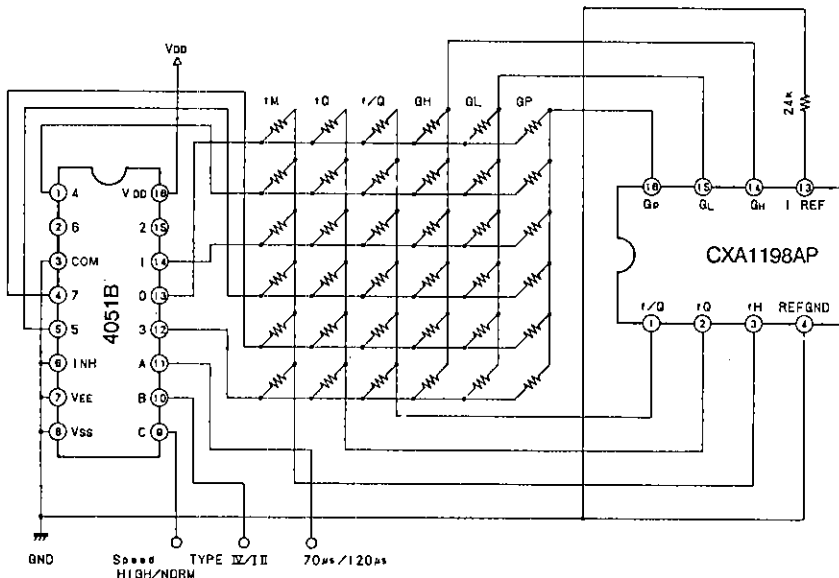

Fig. 8 (b) Single supply

4. Temperature characteristics and accuracy

Temperature characteristics of CXA1198AP can be vastly improved by using resistors RGL, RGH, RGP, RfM, Rf/Q and RfQ that serve to set the respective parameters and resistors that have a temperature coefficient equivalent to that of the 24 kΩ connected to pin 13 (IREF).

Also, enhancing the accuracy of 24 kΩ (IREF) and resistors that set the various parameters will improve the setting accuracy of those parameters.

Application Circuit (Dual supply)

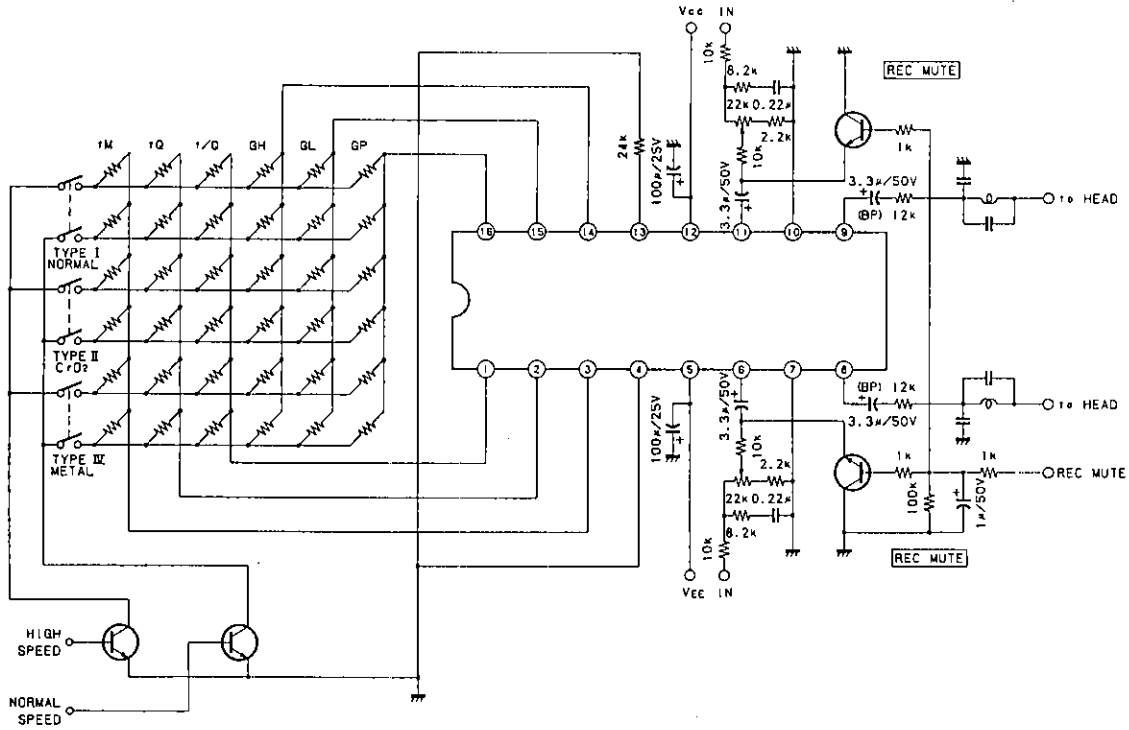

Application Circuit (Single supply)

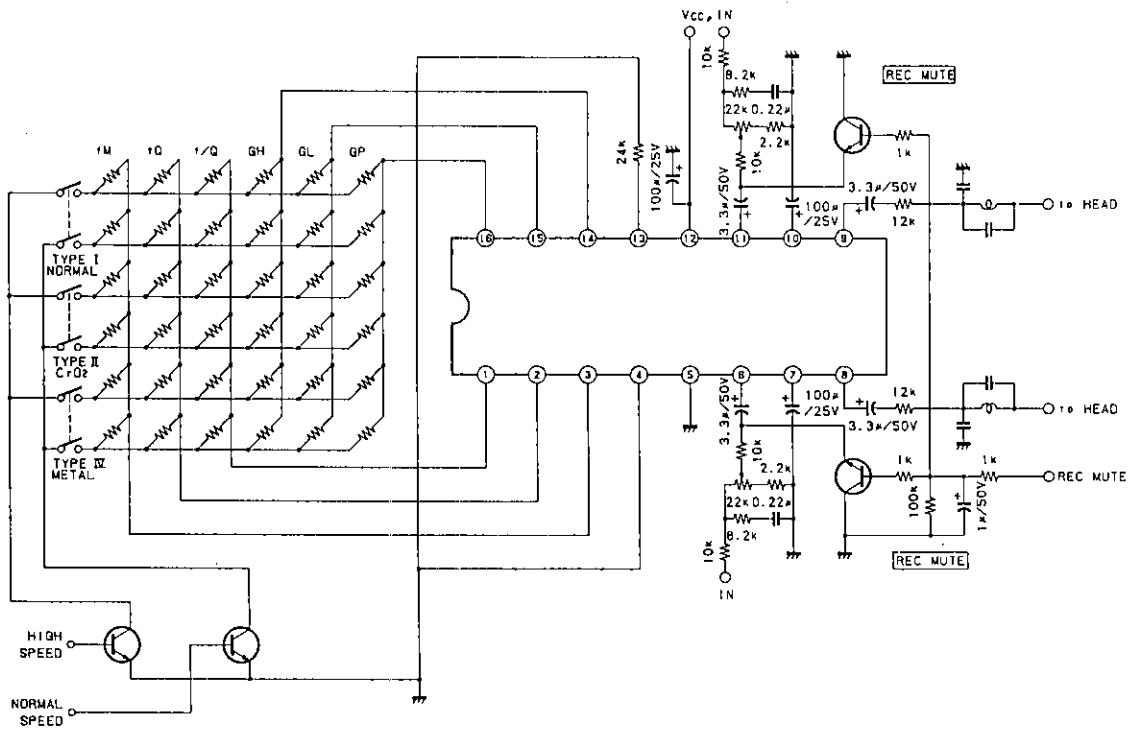

Package Outline Unit:mm

16pin DIP (Plastic) 300mil 1.0g

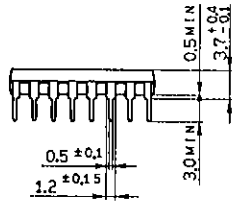
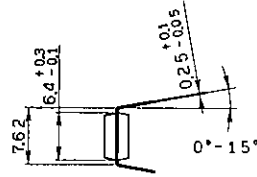
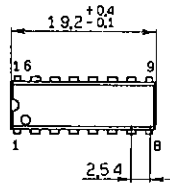

| | |
|------------|------------------|
| SONY NAME | DIP-16P-01 |
| EIAJ NAME | *DIP016-P-0300-A |
| JEDEC CODE | MO-001-AE * |

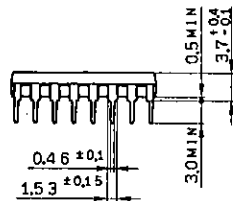
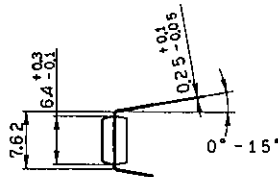
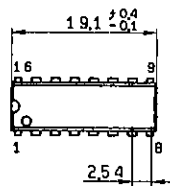

| | |
|------------|------------------|
| SONY NAME | DIP-16P-03 |
| EIAJ NAME | *DIP016-P-0300-B |
| JEDEC CODE | MO-001-AE * |

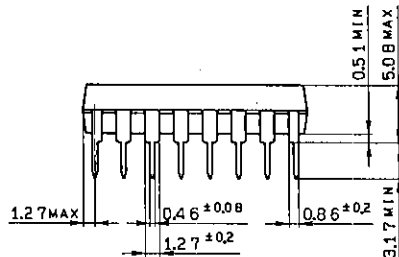
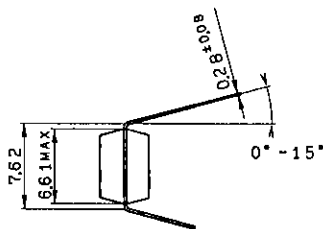
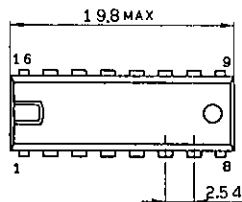

| | |
|------------|-------------------|
| SONY NAME | DIP-16P-121 |
| EIAJ NAME | *DIP016-P-0300-AX |
| JEDEC CODE | MO-001-AG * |

(*Similar)