

# A1441

## Low-Voltage Full-Bridge Brushless DC Motor Driver with Hall Element Commutation

Package EL, 6-pin Surface Mount MLP

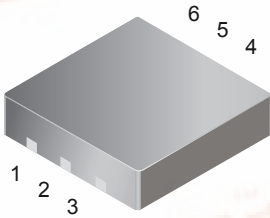

Package EL  
2x2 mm



Approximate Actual Size

### ABSOLUTE MAXIMUM RATINGS

Supply Voltage, $V_{DD}$ .....	5.0 V
Reverse Battery Voltage, $V_{RDD}$ .....	-0.3 V
Output Voltage, $V_{OUT}$ .....	-0.3 V to $V_{DD} + 0.3$ V
Control Input Voltage, $V_{IN(High)}$ .....	-0.3 V to $V_{DD} + 0.3$ V
Load Current*, $I_{LOAD}$ .....	±150 mA
Magnetic Flux Density, B .....	Unlimited
Operating Temperature	
Ambient, $T_A$ , Range S .....	-20°C to 85°C
Maximum Junction, $T_{J(max)}$ .....	165°C
Storage Temperature, $T_S$ .....	-65°C to 170°C

\*Positive  $I_{LOAD}$  flow is from VOUT1 to VOUT2.

The A1441 is a full-bridge motor driver designed to drive low-voltage bipolar brushless dc motors. Commutation of the motor is achieved by use of a single Hall element sensor to detect the position of an alternating-pole ring magnet. A high density merged Bipolar-CMOS semiconductor process allows the integration of the Hall element on the same IC as the motor control circuitry, providing a single-chip solution for enhanced reliability. All necessary circuitry is incorporated within the device package, eliminating the need for any external support components.

A micropower sleep mode can be enabled by an external signal, to reduce current consumption for battery management in portable electronic devices. In addition, the device offers an active function for motor braking.

The A1441 is optimized for vibration motor applications such as cellular phones, pagers, electronic toothbrushes, and hand-held video game controllers. These devices also drive low power fan motors designed with cogging plates.

The small package outline and low profile make this device ideally suited for use in applications where printed circuit board area and component headroom are at a premium. It is available in a lead (Pb) free (leadframe plating 100% matte tin) 6-pin MLP microleadframe package for surface mount, with exposed pad for enhanced thermal dissipation.

### Features and Benefits

- Single-chip solution for high reliability
- Chopper stabilization technique for precise signal response over operating range
- 2.0 to 4.0 V operation
- Sleep mode pin allowing external logic signal enable/disable to reduce average power consumption
- Restart feature
- Small package size



Use the following complete part numbers when ordering:

Part Number	Package	Packing
A1441SELLT-T	2x2x0.50 mm	7-in. Reel, 3000 pieces/reel



# A1441

## Low-Voltage Full-Bridge Brushless DC Motor Driver with Hall Element Commutation

### Functional Block Diagram

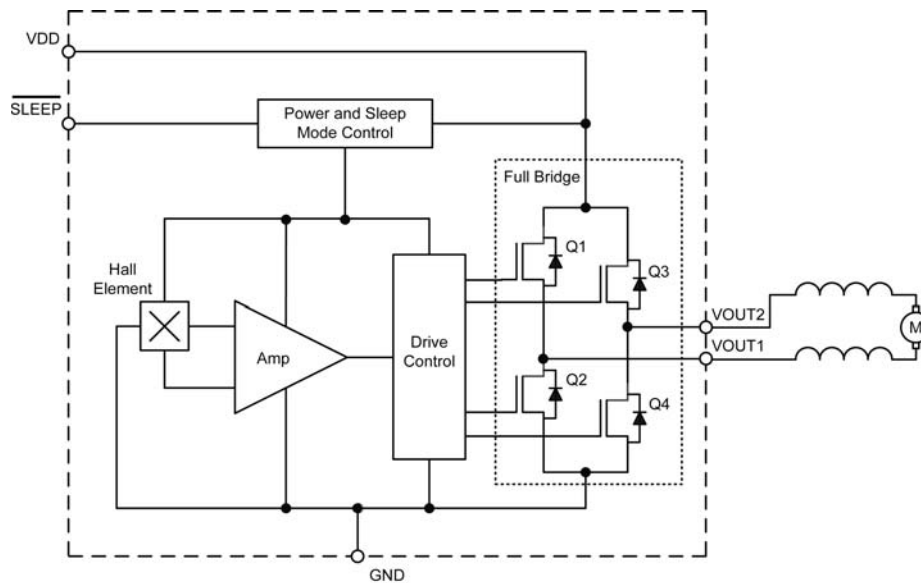

Package EL, 2 × 2 mm, 6-pin Surface Mount MLP

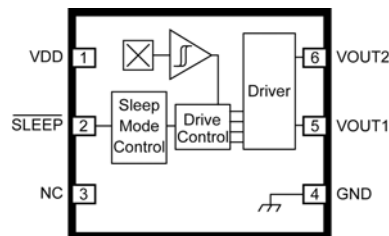

Terminal List Table

Pin	Name	Function
1	VDD	Supply voltage
2	$\overline{\text{SLEEP}}$	Toggle Sleep/Enabled modes
3	NC	No connection
4	GND	Ground
5	VOUT1	First output
6	VOUT2	Second output

# A1441

## Low-Voltage Full-Bridge Brushless DC Motor Driver with Hall Element Commutation

### DEVICE CHARACTERISTICS over the voltage and temperature operating range, unless otherwise specified

Characteristics	Symbol	Test Conditions	Min.	Typ.	Max.	Units	
Supply Voltage	$V_{DD}$	Running	2.0	–	4.0	V	
Total Output Saturation Voltage <sup>1</sup>	$V_{OUT(Sat)}$	$I_{LOAD} = 70 \text{ mA}, V_{DD} = 3.6 \text{ V}$	–	300	–	mV	
		$I_{LOAD} = 100 \text{ mA}, V_{DD} = 3.6 \text{ V}$	–	450	–	mV	
		$I_{LOAD} = 70 \text{ mA}, V_{DD} = 2.2 \text{ V}$	–	400	–	mV	
Sleep Mode Supply Current	$I_{DD(Sleep)}$		–	–	10	$\mu\text{A}$	
Load Current Rise Time <sup>2</sup>	$t_{r(ILOAD)}$	$V_{DD} = 3.6 \text{ V}$	–	10	–	$\mu\text{s}$	
Chopping Settling Time <sup>3</sup>	$t_{s(CHOP)}$		–	30	–	$\mu\text{s}$	
$\overline{\text{SLEEP}}$ Input Threshold	$V_{INLO}$		–	–	0.5	V	
	$V_{INHI}$		$V_{DD}-0.7$	–	–	V	
$\overline{\text{SLEEP}}$ Input Current	$I_{IN}$		–	–	1	$\mu\text{A}$	
Crossover Dead Time <sup>4</sup>	$t_{DT}$	VOUT switching	–	2	–	$\mu\text{s}$	
Restart Delay <sup>5</sup>	$t_{RS}$		–	100	–	ms	
Magnetic Switchpoints	$B_{OP}$		–	35	75	G	
	$B_{RP}$		–75	–35	–	G	
	$B_{HYS}$	$B_{OP} - B_{RP}; B_{OP} > B_{RP}$	–	70	–	G	
Startup Polarity	$V_{OUT1}$	$B < B_{rp}$		LOW		–	
		$B > B_{op}$		HIGH		–	
	$V_{OUT2}$	$B < B_{rp}$			HIGH		–
		$B > B_{op}$			LOW		–

<sup>1</sup>Either  $V_{OUT(Sat)} = V_{Q1(Sat)} + V_{Q4(Sat)}$  or  $V_{OUT(Sat)} = V_{Q2(Sat)} + V_{Q3(Sat)}$ . Total output saturation voltage is a sum of the voltages across the active output transistors.

<sup>2</sup>Time period required for current to change from 10% to 90% of its value.

<sup>3</sup>Chopping settling time is the required time to have valid device output after power up of the device.

<sup>4</sup>Crossover dead time is a time period during which all output transistors are switched off.

<sup>5</sup>Restart delay is a time period during which only one pair of the output transistors is switched on.

# A1441

## Low-Voltage Full-Bridge Brushless DC Motor Driver with Hall Element Commutation

### Package EL, 6-Pin MLP

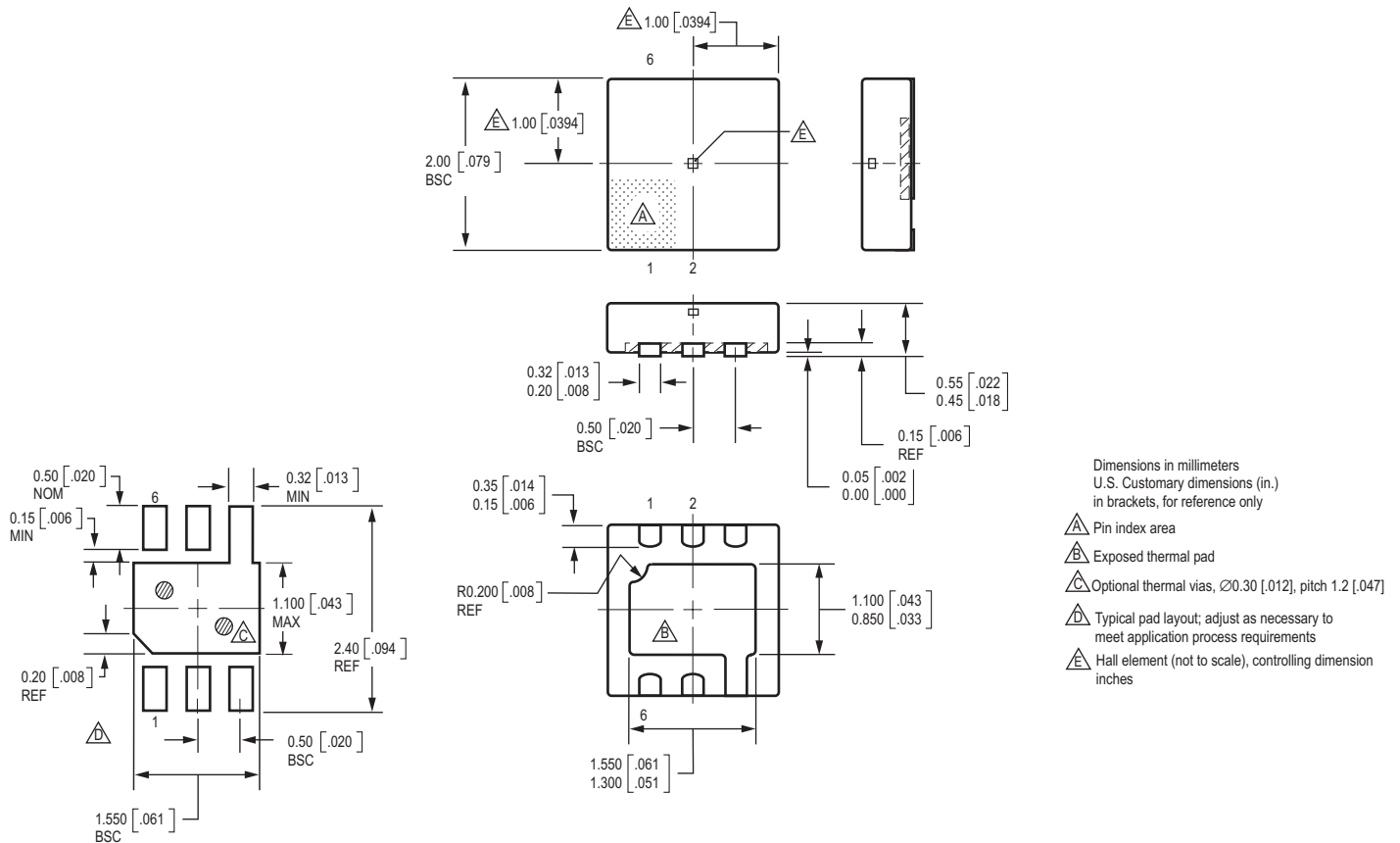

The products described herein are manufactured under one or more of the following U.S. patents: 5,045,920; 5,264,783; 5,442,283; 5,389,889; 5,581,179; 5,517,112; 5,619,137; 5,621,319; 5,650,719; 5,686,894; 5,694,038; 5,729,130; 5,917,320; and other patents pending.

Allegro MicroSystems, Inc. reserves the right to make, from time to time, such departures from the detail specifications as may be required to permit improvements in the performance, reliability, or manufacturability of its products. Before placing an order, the user is cautioned to verify that the information being relied upon is current.

Allegro products are not authorized for use as critical components in life-support devices or systems without express written approval.

The information included herein is believed to be accurate and reliable. However, Allegro MicroSystems, Inc. assumes no responsibility for its use; nor for any infringement of patents or other rights of third parties which may result from its use.

Copyright © 2005, Allegro MicroSystems, Inc.