

# 3959

## DMOS FULL-BRIDGE PWM MOTOR DRIVER

**A3959SLB (SOIC)**

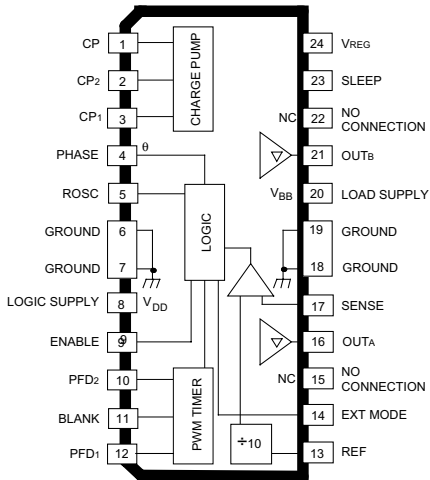

Dwg. PP-069-4

Note that the A3959SLB(SOIC), A3959SB (DIP), and A3959SLP (TSSOP) do not share a common terminal assignment.

### ABSOLUTE MAXIMUM RATINGS

|   |  |
|---|--|
| Load Supply Voltage, $V_{BB}$ .....                     | <b>50 V</b>  |
| Output Current, $I_{OUT}$ (Repetitive) .....            | <b><math>\pm 3.0</math> A</b>                                |
| (Peak, $< 3 \mu s$ ) .....                              | <b><math>\pm 6.0</math> A</b>                                |
| Logic Supply Voltage, $V_{DD}$ .....                    | <b>7.0 V</b>   |
| Logic Input Voltage Range, $V_{IN}$                     |  |
| (Continuous) .....                                      | <b>-0.3 V to <math>V_{DD} + 0.3</math> V</b>                 |
| ( $t_w < 30$ ns) .....                                  | <b>-1.0 V to <math>V_{DD} + 1.0</math> V</b>                 |
| Sense Voltage, $V_S$ (Continuous) .....                 | <b>0.5 V</b>   |
| ( $t_w < 3 \mu s$ ) .....                               | <b>2.5 V</b>   |
| Reference Voltage, $V_{REF}$ .....                      | <b><math>V_{DD}</math></b>                                   |
| Package Power Dissipation ( $T_A = 25^\circ C$ ), $P_D$ |  |
| A3959SB .....   | <b>3.3 W*</b>  |
| A3959SLB .....  | <b>2.5 W*</b>  |
| A3959SLP .....  | <b>3.1 W*</b>  |
| Operating Temp. Range, $T_A$ .....                      | <b><math>-20^\circ C</math> to <math>+85^\circ C</math></b>  |
| Junction Temperature, $T_J$ .....                       | <b><math>+150^\circ C</math></b>                             |
| Storage Temp. Range, $T_S$ .....                        | <b><math>-55^\circ C</math> to <math>+150^\circ C</math></b> |

Output current rating may be limited by duty cycle, ambient temperature, and heat sinking. Under any set of conditions, do not exceed the specified current rating or a junction temperature of  $150^\circ C$ .

\* Double-sided board, one square inch copper each side. See also, Layout, page 7.

Designed for pulse-width modulated (PWM) current control of dc motors, the A3959SB, A3959SLB, and A3959SLP are capable of output currents to  $\pm 3$  A and operating voltages to 50 V. Internal fixed off-time PWM current-control timing circuitry can be adjusted via control inputs to operate in slow, fast, and mixed current-decay modes.

PHASE and ENABLE input terminals are provided for use in controlling the speed and direction of a dc motor with externally applied PWM-control signals. Internal synchronous rectification control circuitry is provided to reduce power dissipation during PWM operation.

Internal circuit protection includes thermal shutdown with hysteresis, undervoltage monitoring of supply and charge pump, and crossover-current protection. Special power-up sequencing is not required.

The A3959SB/SLB/SLP is a choice of three power packages, a 24-pin plastic DIP with a copper batwing tab (package suffix 'B'), a 24-lead plastic SOIC with a copper batwing tab (package suffix 'LB'), and a thin ( $< 1.2$  mm) 28-lead plastic TSSOP with an exposed thermal pad (suffix 'LP'). In all cases, the power tab is at ground potential and needs no electrical isolation. Each package is available in a lead-free version (100% matte tin leadframe).

### FEATURES

- $\pm 3$  A, 50 V Output Rating
- Low  $r_{DS(on)}$  Outputs (270 m $\Omega$ , Typical)
- Mixed, Fast, and Slow Current-Decay Modes
- Synchronous Rectification for Low Power Dissipation
- Internal UVLO and Thermal-Shutdown Circuitry
- Crossover-Current Protection
- Internal Oscillator for Digital PWM Timing

| Part Number  | Pb-free* | $R_{\theta JA}$<br>( $^\circ C/W$ ) | $R_{\theta JT}$<br>( $^\circ C/W$ ) | Package      | Packing       |
|--------------|----------|-------------------------------------|-------------------------------------|--------------|---------------|
| A3959SB-T    | Yes      | 38                                  | 6                                   | 24-Pin DIP   | 25 per tube   |
| A3959SLB-T   | Yes      | 50                                  | 6                                   | 24-Lead SOIC | 47 per tube   |
| A3959SLBTR-T | Yes      | 50                                  | 6                                   | 24-Lead SOIC | 1000 per reel |
| A3959SLP-T   | Yes      | 40                                  | -                                   | 28-pin TSSOP | 50 per tube   |
| A3959SLPTR-T | Yes      | 40                                  | -                                   | 28-pin TSSOP | 4000 per reel |

\*Pb-based variants are being phased out of the product line. The variants cited in this footnote are in production but have been determined to be LAST TIME BUY. This classification indicates that sale of this device is currently restricted to existing customer applications. The variants should not be purchased for new design applications because obsolescence in the near future is probable. Samples are no longer available. Status change: October 31, 2006. Deadline for receipt for LAST TIME BUY orders: April 27, 2007. These variants include: A3959SB, A3959SLB, A3959SLBTR, A3959SLP, and A3959SLPTR.

# 3959 DMOS FULL-BRIDGE PWM MOTOR DRIVER

## FUNCTIONAL BLOCK DIAGRAM

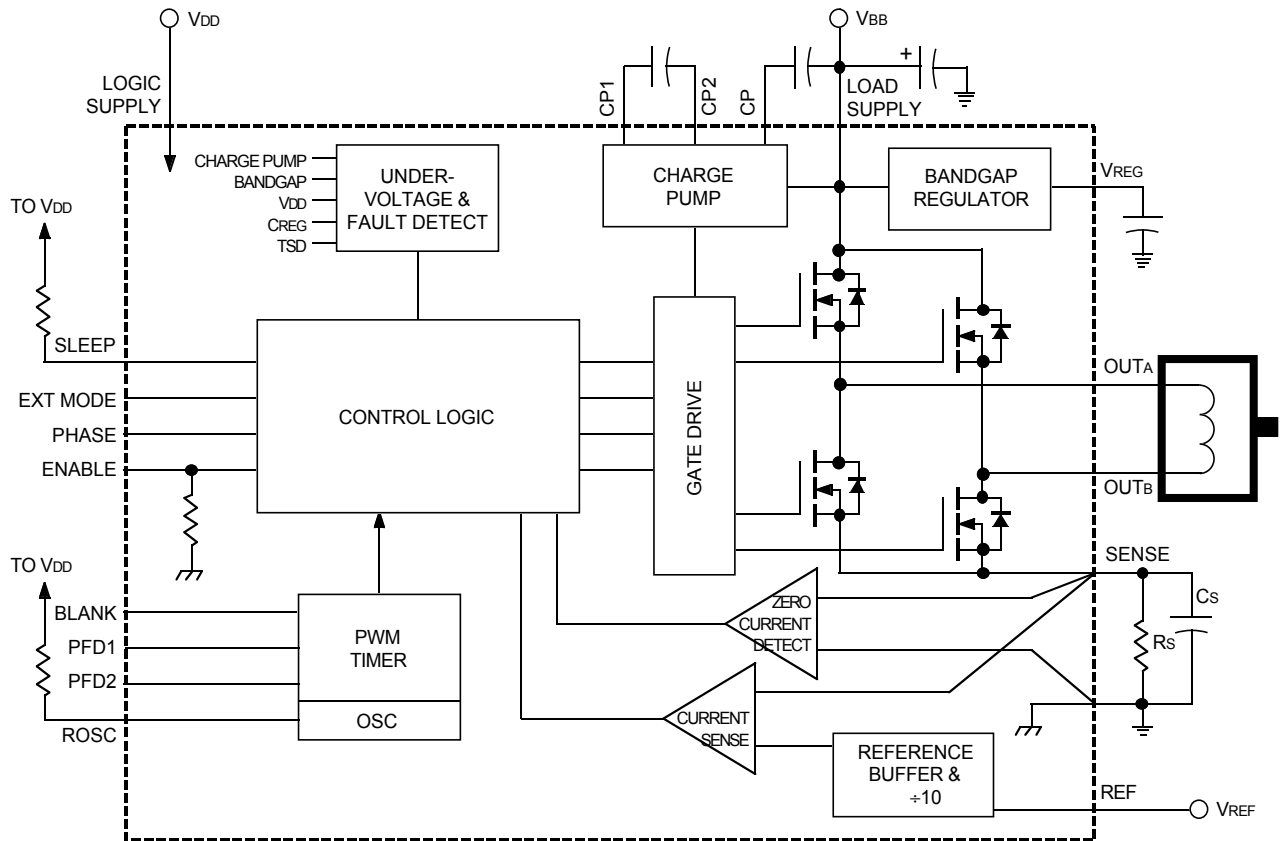

Dwg. FP-048-2A

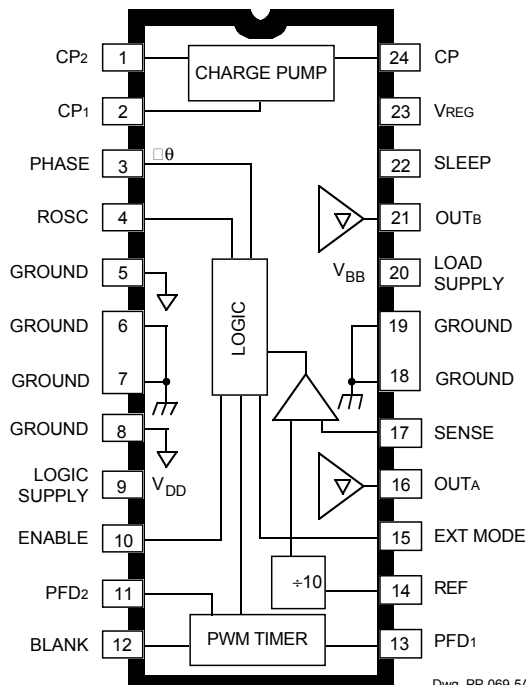

Dwg. PP-069-5A

### A3959SB (DIP)

Note that the A3959SLB (SOIC), A3959SB (DIP), and A3959SLP (TSSOP) do not share a common terminal assignment.

**3959**  
**DMOS FULL-BRIDGE**  
**PWM MOTOR DRIVER**

**ELECTRICAL CHARACTERISTICS** at  $T_A = +25^\circ\text{C}$ ,  $V_{BB} = 50\text{ V}$ ,  $V_{DD} = 5.0\text{ V}$ ,  $V_{SENSE} = 0.5\text{ V}$ ,  $f_{PWM} < 50\text{ kHz}$  (unless noted otherwise)

| Characteristics                                   | Symbol       | Test Conditions                        | Limits |           |           |                  |
|---|--------------|--|--------|-----------|-----------|------------------|
|   |              |  | Min.   | Typ.      | Max.      | Units            |
| <b>Output Drivers</b>                             |              |  |        |           |           |                  |
| Load Supply Voltage Range                         | $V_{BB}$     | Operating                              | 9.5    | –         | 50        | V                |
|   |              | During sleep mode                      | 0      | –         | 50        | V                |
| Output Leakage Current                            | $I_{DSS}$    | $V_{OUT} = V_{BB}$                     | –      | <1.0      | 20        | $\mu\text{A}$    |
|   |              | $V_{OUT} = 0\text{ V}$                 | –      | <-1.0     | -20       | $\mu\text{A}$    |
| Output On Resistance                              | $r_{DS(on)}$ | Source driver, $I_{OUT} = -3\text{ A}$ | –      | 270       | 300       | $\text{m}\Omega$ |
|   |              | Sink driver, $I_{OUT} = 3\text{ A}$    | –      | 270       | 300       | $\text{m}\Omega$ |
| Crossover Delay                                   |              |  | 300    | 600       | 1000      | ns               |
| Body Diode Forward Voltage                        | $V_F$        | Source diode, $I_F = -3\text{ A}$      | –      | –         | 1.6       | V                |
|   |              | Sink diode, $I_F = 3\text{ A}$         | –      | –         | 1.6       | V                |
| Load Supply Current                               | $I_{BB}$     | $f_{PWM} < 50\text{ kHz}$              | –      | 4.0       | 7.0       | mA               |
|   |              | Charge pump on, outputs disabled       | –      | 2.0       | 5.0       | mA               |
|   |              | Sleep Mode                             | –      | –         | 20        | $\mu\text{A}$    |
| <b>Control Logic</b>                              |              |  |        |           |           |                  |
| Logic Supply Voltage Range                        | $V_{DD}$     | Operating                              | 4.5    | 5.0       | 5.5       | V                |
| Logic Input Voltage                               | $V_{IN(1)}$  |  | 2.0    | –         | –         | V                |
|   | $V_{IN(0)}$  |  | –      | –         | 0.8       | V                |
| Logic Input Current<br>(all inputs except ENABLE) | $I_{IN(1)}$  | $V_{IN} = 2.0\text{ V}$                | –      | <1.0      | 20        | $\mu\text{A}$    |
|   | $I_{IN(0)}$  | $V_{IN} = 0.8\text{ V}$                | –      | <-2.0     | -20       | $\mu\text{A}$    |
| ENABLE Input Current                              | $I_{IN(1)}$  | $V_{IN} = 2.0\text{ V}$                | –      | 40        | 100       | $\mu\text{A}$    |
|   | $I_{IN(0)}$  | $V_{IN} = 0.8\text{ V}$                | –      | 16        | 40        | $\mu\text{A}$    |
| Internal OSC frequency                            | $f_{OSC}$    | $R_{OSC}$ shorted to GROUND            | 3.25   | 4.25      | 5.25      | MHz              |
|   |              | $R_{OSC} = 51\text{ k}\Omega$          | 3.65   | 4.25      | 4.85      | MHz              |
| Reference Input Volt. Range                       | $V_{REF}$    | Operating                              | 0.0    | –         | $V_{DD}$  | V                |
| Reference Input Current                           | $I_{REF}$    | $V_{REF} = V_{DD}$                     | –      | –         | $\pm 1.0$ | $\mu\text{A}$    |
| Comparator Input Offset Volt.                     | $V_{IO}$     | $V_{REF} = 0\text{ V}$                 | –      | $\pm 5.0$ | –         | mV               |

Continued next page ...

# 3959

## DMOS FULL-BRIDGE PWM MOTOR DRIVER

**ELECTRICAL CHARACTERISTICS** at  $T_A = +25^\circ\text{C}$ ,  $V_{BB} = 50\text{ V}$ ,  $V_{DD} = 5.0\text{ V}$ ,  $V_{SENSE} = 0.5\text{ V}$ ,  $f_{PWM} < 50\text{ kHz}$  (unless noted otherwise), continued.

| Characteristics                  | Symbol          | Test Conditions                               | Limits |      |      |       |
|----------------------------------|-----------------|---|--------|------|------|-------|
|                                  |                 |   | Min.   | Typ. | Max. | Units |
| <b>Control Logic</b>             |                 |   |        |      |      |       |
| Reference Divider Ratio          | –               |   | –      | 10   | –    | –     |
| G <sub>m</sub> Error<br>(Note 3) | E <sub>Gm</sub> | V <sub>REF</sub> = V <sub>DD</sub>            | –      | –    | ±4.0 | %     |
|                                  |                 | V <sub>REF</sub> = 0.5 V                      | –      | –    | ±14  | %     |
| Propagation Delay Times          | t <sub>pd</sub> | 0.5 E <sub>in</sub> to 0.9 E <sub>out</sub> : |        |      |      |       |
|                                  |                 | PWM change to source on                       | 600    | 750  | 1200 | ns    |
|                                  |                 | PWM change to source off                      | 50     | 150  | 350  | ns    |
|                                  |                 | PWM change to sink on                         | 600    | 750  | 1200 | ns    |
|                                  |                 | PWM change to sink off                        | 50     | 100  | 150  | ns    |
| Thermal Shutdown Temp.           | T <sub>J</sub>  |   | –      | 165  | –    | °C    |
| Thermal Shutdown Hysteresis      | ΔT <sub>J</sub> |   | –      | 15   | –    | °C    |
| UVLO Enable Threshold            | UVLO            | Increasing V <sub>DD</sub>                    | 3.90   | 4.2  | 4.45 | V     |
| UVLO Hysteresis                  | ΔUVLO           |   | 0.05   | 0.10 | –    | V     |
| Logic Supply Current             | I <sub>DD</sub> | f <sub>PWM</sub> < 50 kHz                     | –      | 6.0  | 10   | mA    |
|                                  |                 | Sleep Mode                                    | –      | –    | 2.0  | mA    |

- NOTES:
1. Typical Data is for design information only.
  2. Negative current is defined as coming out of (sourcing) the specified device terminal.
  3. G<sub>m</sub> error =  $([V_{REF}/10] - V_{SENSE}) / (V_{REF}/10)$  where  $V_{SENSE} = I_{TRIP} \cdot R_S$ .

# 3959

## *DMOS FULL-BRIDGE PWM MOTOR DRIVER*

### FUNCTIONAL DESCRIPTION

**V<sub>REG</sub>.** This internally generated voltage is used to operate the sink-side DMOS outputs. The V<sub>REG</sub> terminal should be decoupled with a 0.22 μF capacitor to ground. V<sub>REG</sub> is internally monitored and in the case of a fault condition, the outputs of the device are disabled.

**Charge Pump.** The charge pump is used to generate a gate-supply voltage greater than V<sub>BB</sub> to drive the source-side DMOS gates. A 0.22 μF ceramic capacitor should be connected between CP1 and CP2 for pumping purposes. A 0.22 μF ceramic capacitor should be connected between CP and V<sub>BB</sub> to act as a reservoir to operate the high-side DMOS devices. The CP voltage is internally monitored and, in the case of a fault condition, the source outputs of the device are disabled.

**PHASE Logic.** The PHASE input terminal determines if the device is operating in the “forward” or “reverse” state.

| PHASE | OUT <sub>A</sub> | OUT <sub>B</sub> |
|-------|------------------|------------------|
| 0     | Low              | High             |
| 1     | High             | Low              |

**ENABLE Logic.** The ENABLE input terminal allows external PWM. ENABLE high turns on the selected sink-source pair. ENABLE low switches off the source driver or the source and sink driver, depending on EXT MODE, and the load current decays. If ENABLE is kept high, the current will rise until it reaches the level set by the internal current-control circuit.

| ENABLE | Outputs |
|--------|---------|
| 0      | Chopped |
| 1      | On      |

**EXT MODE Logic.** When using external PWM current control, the EXT MODE input determines the current path during the chopped cycle. With EXT MODE low, fast decay mode, the opposite pair of selected outputs will be enabled during the off cycle. With EXT MODE high, slow decay mode, both sink drivers are on with ENABLE low.

| EXT MODE | Decay |
|----------|-------|
| 0        | Fast  |
| 1        | Slow  |

**Current Regulation.** Load current is regulated by an internal fixed off-time PWM control circuit. When the outputs of the DMOS H bridge are turned on, the current increases in the motor winding until it reaches a trip value determined by the external sense resistor (R<sub>S</sub>) and the applied analog reference voltage (V<sub>REF</sub>):

$$I_{TRIP} = V_{REF}/10R_S$$

At the trip point, the sense comparator resets the source-enable latch, turning off the source driver. The load inductance then causes the current to recirculate for the fixed off-time period. The current path during recirculation is determined by the configuration of slow/mixed/fast current-decay mode via PFD1 and PFD2.

**Oscillator.** The PWM timer is based on an internal oscillator set by a resistor connected from the R<sub>OSC</sub> terminal to V<sub>DD</sub>. Typical value of 4 MHz is set with a 51 kΩ resistor. The allowable range of the resistor is from 20 kΩ to 100 kΩ.

$$f_{OSC} = 204 \times 10^9/R_{OSC}$$

If R<sub>OSC</sub> is not pulled up to V<sub>DD</sub>, it must be shorted to ground.

**Fixed Off Time.** The A3959 is set for a fixed off time of 96 cycles of the internal oscillator, typically 24 μs with a 4 MHz oscillator.

# 3959

## DMOS FULL-BRIDGE PWM MOTOR DRIVER

### FUNCTIONAL DESCRIPTION (continued)

**Internal Current-Control Mode.** Inputs PFD1 and PFD2 determine the current-decay method after an overcurrent event is detected at the SENSE input. In slow-decay mode, both sink drivers are turned on for the fixed off-time period. Mixed-decay mode starts out in fast-decay mode for a portion (15% or 48%) of the fixed off time, and then is followed by slow decay for the remainder of the period.

| PFD2 | PFD1 | % $t_{off}$ | Decay |
|------|------|-------------|-------|
| 0    | 0    | 0           | Slow  |
| 0    | 1    | 15          | Mixed |
| 1    | 0    | 48          | Mixed |
| 1    | 1    | 100         | Fast  |

**PWM Blank Timer.** When a source driver turns on, a current spike occurs due to the reverse-recovery currents of the clamp diodes and/or switching transients related to distributed capacitance in the load. To prevent this current spike from erroneously resetting the source-enable latch, the sense comparator is blanked. The blank timer runs after the off-time counter to provide the blanking function. The blank timer is reset when ENABLE is chopped or PHASE is changed. For external PWM control, a PHASE change or ENABLE on will trigger the blanking function. The duration is determined by the BLANK input and the oscillator.

| BLANK | $t_{blank}$  |
|-------|--------------|
| 0     | $6/f_{osc}$  |
| 1     | $12/f_{osc}$ |

**Synchronous Rectification.** When a PWM off cycle is triggered, either by an ENABLE chop command or internal fixed off-time cycle, load current will recirculate according to the decay mode selected by the control logic.

The A3959 synchronous rectification feature will turn on the appropriate pair of DMOS outputs during the current decay and effectively short out the body diodes with the low  $r_{DS(on)}$  driver. This will reduce power dissipation significantly and can eliminate the need for external Schottky diodes.

Synchronous rectification will prevent reversal of load current by turning off all outputs when a zero-current level is detected.

**Shutdown.** In the event of a fault (excessive junction temperature, or low voltage on CP or  $V_{REG}$ ) the outputs of the device are disabled until the fault condition is removed. At power up, and in the event of low  $V_{DD}$ , the UVLO circuit disables the drivers.

**Braking.** The braking function is implemented by driving the device in slow-decay mode via EXTMODE and applying an enable chop command. Because it is possible to drive current in either direction through the DMOS drivers, this configuration effectively shorts out the motor-generated BEMF as long as the ENABLE chop mode is asserted. It is important to note that the internal PWM current-control circuit will not limit the current when braking, because the current does not flow through the sense resistor. The maximum brake current can be approximated by  $V_{BEMF}/R_L$ . Care should be taken to ensure that the maximum ratings of the device are not exceeded in worst-case braking situations of high speed and high inertial loads.

**SLEEP Logic.** The SLEEP input terminal is used to minimize power consumption when not in use. This disables much of the internal circuitry including the regulator and charge pump. Logic low will put the device into sleep mode, logic high will allow normal operation.

Note: If the SLEEP mode is not used, a 1 k $\Omega$  or 2 k $\Omega$  pull-up resistor is required on the SLEEP input terminal.

## FUNCTIONAL DESCRIPTION (continued)

**Current Sensing.** To minimize inaccuracies in sensing the  $I_{TRIP}$  current level, which may be caused by ground trace IR drops, the sense resistor should have an independent ground return to the ground terminal of the device. For low-value sense resistors the IR drops in the PCB sense resistor's traces can be significant and should be taken into account. The use of sockets should be avoided as they can introduce variation in  $R_S$  due to their contact resistance.

The maximum value of  $R_S$  is given as  $R_S \leq 0.5/I_{TRIP}$  where  $I_{TRIP} \leq 3.0$  A.

**Thermal Protection.** Circuitry turns off all drivers when the junction temperature reaches 165°C typically. It is intended only to protect the device from failures due to excessive junction temperatures and should not imply that output short circuits are permitted. Thermal shutdown has a hysteresis of approximately 15°C.

**Layout.** A star ground system located close to the driver is recommended. The printed wiring board should use a heavy ground plane. For optimum electrical and thermal performance\*, the driver should be soldered directly onto the board. The ground side of  $R_S$  should have an individual path to the ground terminals of the device. This path should be as short as is possible physically and should not have any other components connected to it. It is recommended that a 0.1  $\mu$ F capacitor be placed between SENSE and ground as close to the device as possible; the load supply terminal,  $V_{BB}$ , should be decoupled with an electrolytic capacitor (> 47  $\mu$ F is recommended) placed as close to the device as is possible. On the 28-lead TSSOP package, the copper ground plane located under the exposed thermal pad is typically used as a star ground.

\* The thermal resistance,  $R_{\theta JA}$ , and absolute maximum allowable package power dissipation specified on page 1 is measured on a typical two-sided PCB with one square inch copper ground area on each side. With minimal copper on a single-sided PCB (worst-case), the 'B' package  $R_{\theta JA}$  is 40°C/W, 'LB' is 77°C/W, and 'LP' is 80°C/W. See also, Application Note 29501.5, *Improving Batwing Power Dissipation*.

For specification purposes, the multi-layer high-K board performance graphed here is per JEDEC Standard JESD51.

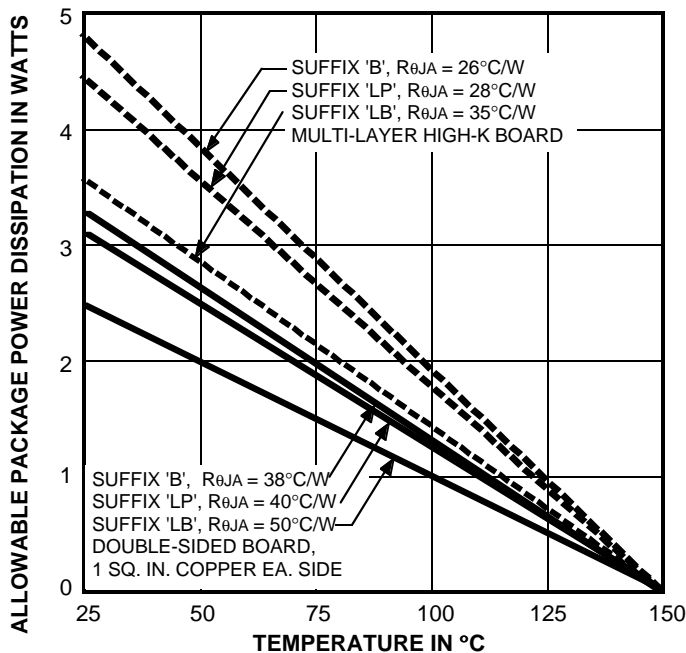

Dwg. GP-049-6

*The products described here are manufactured under one or more U.S. patents or U.S. patents pending.*

*Allegro MicroSystems, Inc. reserves the right to make, from time to time, such departures from the detail specifications as may be required to permit improvements in the performance, reliability, or manufacturability of its products. Before placing an order, the user is cautioned to verify that the information being relied upon is current.*

*Allegro products are not authorized for use as critical components in life-support devices or systems without express written approval.*

*The information included herein is believed to be accurate and reliable. However, Allegro MicroSystems, Inc. assumes no responsibility for its use; nor for any infringement of patents or other rights of third parties which may result from its use.*

# 3959

## DMOS FULL-BRIDGE PWM MOTOR DRIVER

### Terminal List

| Terminal Name    | Terminal Description                                     | LB<br>(SOIC) | B<br>(DIP)  | LP<br>(TSSOP) |
|------------------|--|--------------|-------------|---------------|
| CP               | Reservoir capacitor (typically 0.22 $\mu$ F)             | 1            | 24          | 1             |
| CP1 & CP2        | The charge pump capacitor (typically 0.22 $\mu$ F)       | 2 & 3        | 1 & 2       | 2 & 3         |
| NC               | No (internal) connection                                 | —            | —           | 4             |
| PHASE            | Logic input for direction control                        | 4            | 3           | 5             |
| ROSC             | Oscillator resistor                                      | 5            | 4           | 6             |
| GROUND           | Grounds  | 6, 7         | 5, 6, 7, 8* | 7, 8*         |
| LOGIC SUPPLY     | $V_{DD}$ , the low voltage (typically 5 V) supply        | 8            | 9           | 9             |
| ENABLE           | Logic input for enable control                           | 9            | 10          | 10            |
| NC               | No (internal) connection                                 | —            | —           | 11            |
| PFD2             | Logic-level input for fast decay                         | 10           | 11          | 12            |
| BLANK            | Logic-level input for blanking control                   | 11           | 12          | 13            |
| PFD1             | Logic-level input for fast decay                         | 12           | 13          | 14            |
| REF              | $V_{REF}$ , the load current reference input voltage     | 13           | 14          | 15            |
| EXT MODE         | Logic input for PWM mode control                         | 14           | 15          | 16            |
| NO CONNECT       | No (Internal) connection                                 | 15           | —           | 17            |
| OUT <sub>A</sub> | One of two DMOS bridge outputs to the motor              | 16           | 16          | 18            |
| NC               | No (internal) connection                                 | —            | —           | 19, 20        |
| SENSE            | Sense resistor   | 17           | 17          | 21            |
| NC               | No (internal) connection                                 | —            | —           | 22            |
| GROUND           | Grounds  | 18, 19       | 18, 19*     | —             |
| LOAD SUPPLY      | $V_{BB}$ , the high-current, 9.5 V to 50 V, motor supply | 20           | 20          | 23            |
| OUT <sub>B</sub> | One of two DMOS bridge outputs to the motor              | 21           | 21          | 24            |
| NO CONNECT       | No (Internal) connection                                 | 22           | —           | 25            |
| SLEEP            | Logic-level Input for sleep operation                    | 23           | 22          | 26            |
| $V_{REG}$        | Regulator decoupling capacitor (typically 0.22 $\mu$ F)  | 24           | 23          | 27            |
| GROUND           | Ground   | —            | —           | 28*           |

\* For the A3959SB (DIP) only, there is an indeterminate resistance between the substrate grounds (pins 6, 7, 18, and 19) and the grounds at pins 5 and 8. Pins 5 and 8, and 6, 7, 18, or 19 must be connected together externally. For the A3959SLP (TSSOP) the grounds at terminals 7, 8, and 28 should be connected together at the exposed pad beneath the device.



# 3959 DMOS FULL-BRIDGE PWM MOTOR DRIVER

## A3959SB

Dimensions in Inches  
(controlling dimensions)

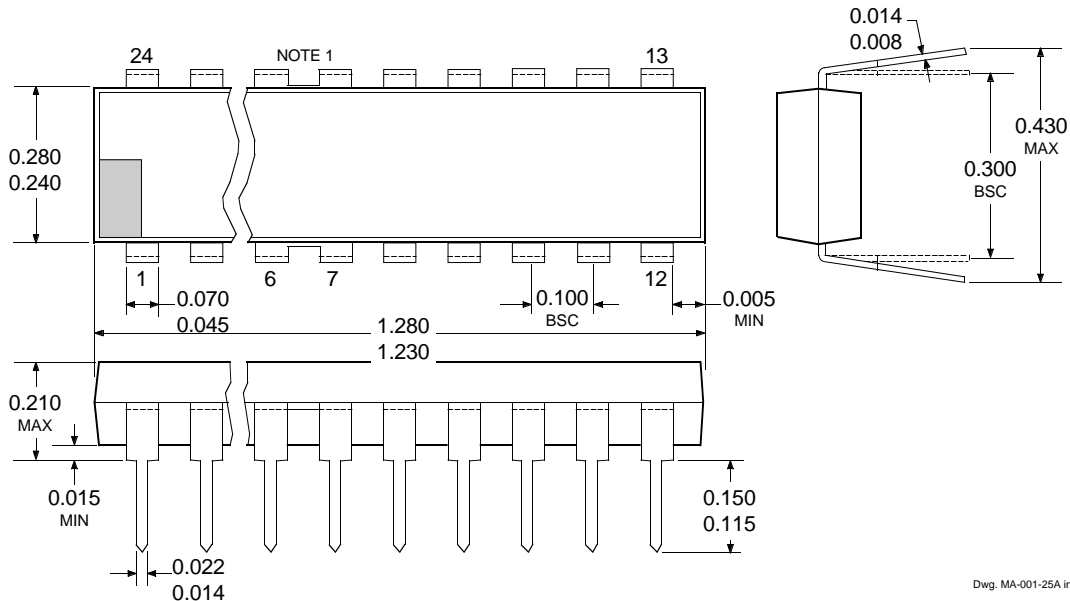

Dimensions in Millimeters  
(for reference only)

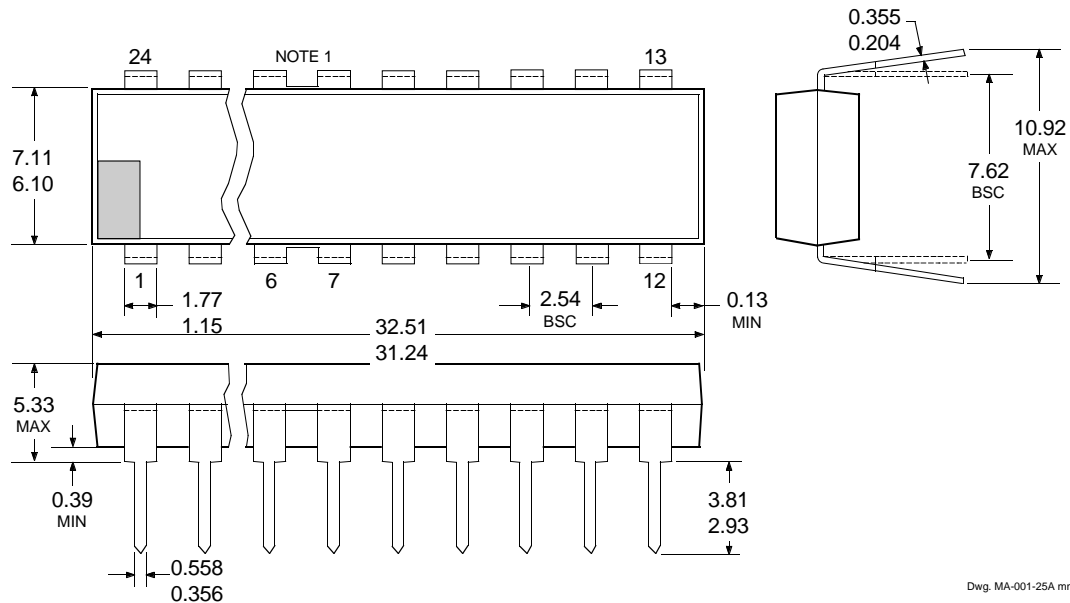

- NOTES: 1. Webbed lead frame. Leads 6, 7, 18, and 19 are internally one piece.  
 2. Exact body and lead configuration at vendor's option within limits shown.  
 3. Lead spacing tolerance is non-cumulative.  
 4. Lead thickness is measured at seating plane or below.  
 5. Supplied in standard sticks/tubes of 15 devices.

# 3959 DMOS FULL-BRIDGE PWM MOTOR DRIVER

## A3959SLB

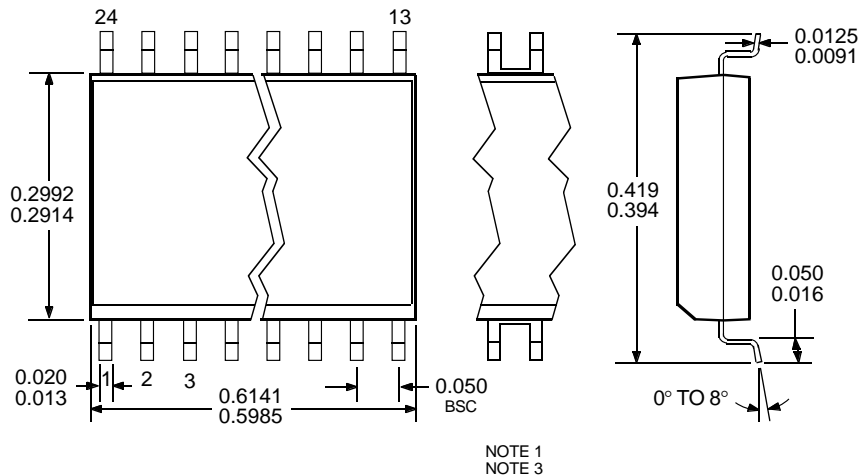

Dimensions in Inches  
(for reference only)

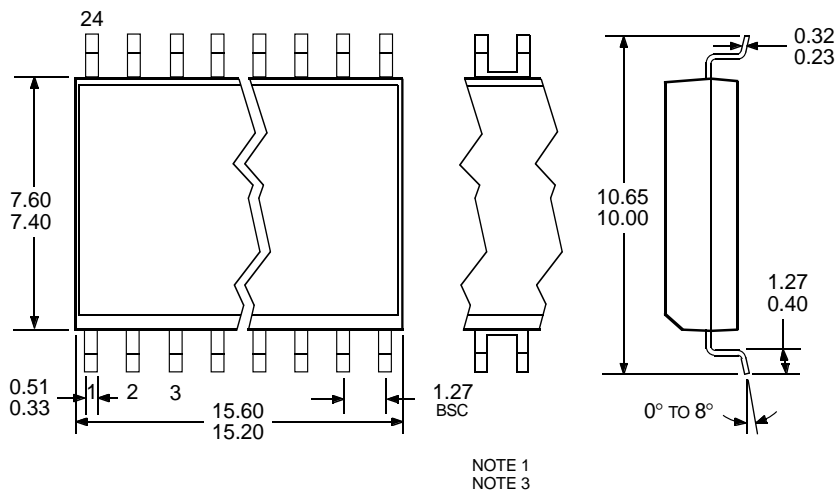
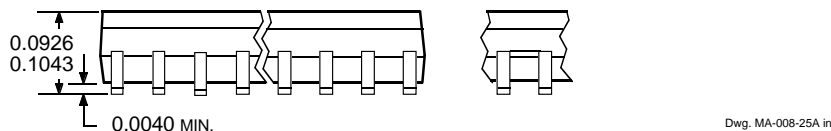

Dimensions in Millimeters  
(controlling dimensions)

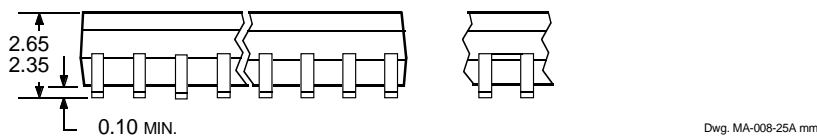

- NOTES: 1. Exact body and lead configuration at vendor's option within limits shown.  
 2. Lead spacing tolerance is non-cumulative.  
 3. Webbed lead frame. Leads 6, 7, 18, and 19 are internally one piece.  
 4. Supplied in standard sticks/tubes of 31 devices or add "TR" to part number for tape and reel.

# 3959 DMOS FULL-BRIDGE PWM MOTOR DRIVER

## A3959SLP 28-pin TSSOP

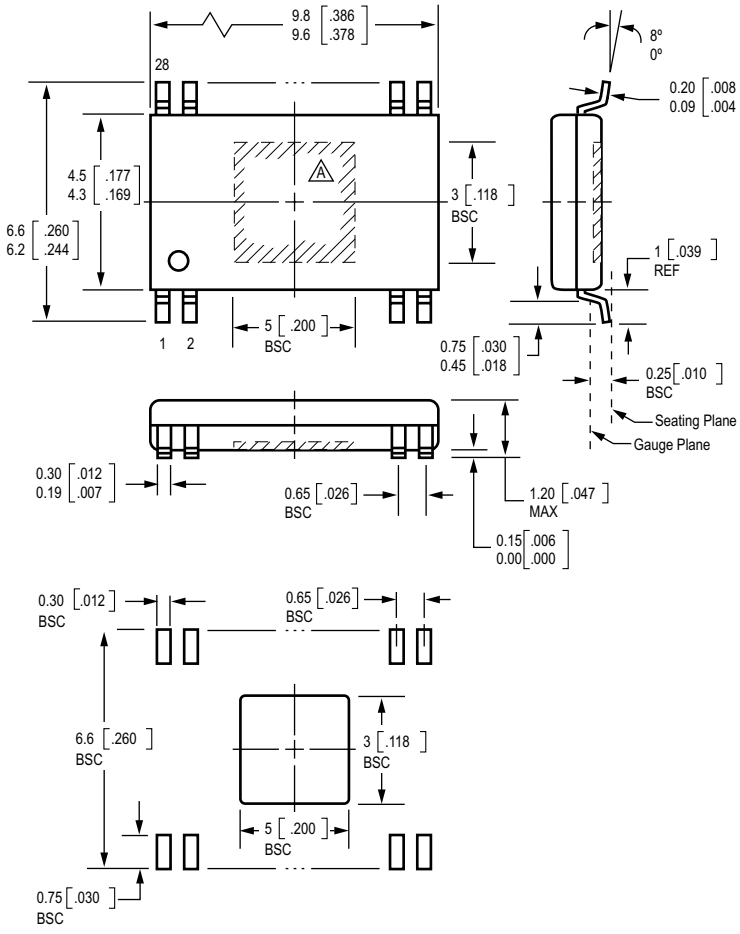

Dimensions in millimeters  
 U.S. Customary dimensions (in.) in brackets, for reference only  
 ⚠ Exposed thermal pad (bottom surface)

**3959**  
**DMOS FULL-BRIDGE**  
**PWM MOTOR DRIVER**

**MOTOR DRIVERS**

| Function   | Output Ratings* |      | Part Number† |
|--|-----------------|------|--------------|
| <b>INTEGRATED CIRCUITS FOR BRUSHLESS DC MOTORS</b>                 |                 |      |              |
| 3-Phase Power MOSFET Controller                                    | —               | 28 V | 3933         |
| 3-Phase Power MOSFET Controller                                    | —               | 40 V | 3935         |
| 3-Phase Power MOSFET Controller                                    | —               | 50 V | 3932 & 3938  |
| 3-Phase Back-EMF Controller/Driver                                 | ±900 mA         | 14 V | 8904         |
| 3-Phase PWM Current-Controlled DMOS Driver                         | ±3.0 A          | 50 V | 3936         |
| <b>INTEGRATED BRIDGE DRIVERS FOR DC AND BIPOLAR STEPPER MOTORS</b> |                 |      |              |
| PWM Current-Controlled Dual Full Bridge                            | ±500 mA         | 18 V | 3965         |
| Dual Full Bridge with Protection & Diagnostics                     | ±500 mA         | 30 V | 3976         |
| PWM Current-Controlled Dual Full Bridge                            | ±650 mA         | 30 V | 3966         |
| PWM Current-Controlled Dual Full Bridge                            | ±650 mA         | 30 V | 3968         |
| Microstepping Translator/Dual Full Bridge                          | ±750 mA         | 30 V | 3967         |
| PWM Current-Controlled Dual Full Bridge                            | ±750 mA         | 45 V | 2916         |
| PWM Current-Controlled Dual Full Bridge                            | ±750 mA         | 45 V | 2919         |
| PWM Current-Controlled Dual Full Bridge                            | ±750 mA         | 45 V | 6219         |
| PWM Current-Controlled Dual Full Bridge                            | ±800 mA         | 33 V | 3964         |
| PWM Current-Controlled Dual DMOS Full Bridge                       | ±1.0 A          | 35 V | 3973         |
| PWM Current-Controlled Full Bridge                                 | ±1.3 A          | 50 V | 3953         |
| PWM Current-Controlled Dual Full Bridge                            | ±1.5 A          | 45 V | 2917         |
| PWM Current-Controlled DMOS Full Bridge                            | ±1.5 A          | 50 V | 3948         |
| PWM Current-Controlled Microstepping Full Bridge                   | ±1.5 A          | 50 V | 3955         |
| PWM Current-Controlled Microstepping Full Bridge                   | ±1.5 A          | 50 V | 3957         |
| PWM Current-Controlled Dual DMOS Full Bridge                       | ±1.5 A          | 50 V | 3972         |
| PWM Current-Controlled Dual DMOS Full Bridge                       | ±1.5 A          | 50 V | 3974         |
| PWM Current-Controlled Full Bridge                                 | ±2.0 A          | 50 V | 3952         |
| PWM Current-Controlled DMOS Full Bridge                            | ±2.0 A          | 50 V | 3958         |
| Microstepping Translator/Dual DMOS Full Bridge                     | ±2.5 A          | 35 V | 3977         |
| PWM Current-Controlled DMOS Full Bridge                            | ±3.0 A          | 50 V | 3959         |
| <b>UNIPOLAR STEPPER MOTOR &amp; OTHER DRIVERS</b>                  |                 |      |              |
| Unipolar Stepper-Motor Translator/Driver                           | 1.0 A           | 46 V | 7050         |
| Unipolar Stepper-Motor Translator/Driver                           | 1.25 A          | 50 V | 5804         |
| Unipolar Stepper-Motor Quad Drivers                                | 1.5 A           | 46 V | 7024 & 7029  |
| Unipolar Microstepper-Motor Quad Driver                            | 1.5 A           | 46 V | 7042         |
| Unipolar Stepper-Motor Quad Driver                                 | 1.8 A           | 50 V | 2540         |
| Unipolar Stepper-Motor Translator/Driver                           | 2.0 A           | 46 V | 7051         |
| Unipolar Stepper-Motor Quad Driver                                 | 3.0 A           | 46 V | 7026         |
| Unipolar Microstepper-Motor Quad Driver                            | 3.0 A           | 46 V | 7044         |
| Unipolar Stepper-Motor Translator/Driver                           | 3.0 A           | 46 V | 7052         |

\* Current is maximum specified test condition, voltage is maximum rating. See specification for sustaining voltage limits or over-current protection voltage limits. Negative current is defined as coming out of (sourcing) the output.

† Complete part number includes additional characters to indicate operating temperature range and package style.

Also, see 3175, 3177, 3235, and 3275 Hall-effect sensors for use with brushless dc motors.