

# PRELIMINARY INFORMATION

(Subject to change without notice)

December 1, 2000

# 3973

Data Sheet  
29319-34b

## DUAL DMOS FULL-BRIDGE MICROSTEPPING PWM MOTOR DRIVER

Designed for pulse-width modulated (PWM) current control of bipolar microstepping stepper motors, the A3973SB and A3973SLB are capable of continuous output currents to  $\pm 1$  A and operating voltages to 35 V. Internal fixed off-time PWM current-control timing circuitry can be programmed via a serial interface to operate in slow, fast, and mixed current-decay modes. The A3973SB (DIP) and the A3973SLB (SOIC) are electrically identical and differ only in package style.

The desired load-current level is set via the serial port with two 6-bit linear DACs in conjunction with a reference voltage. The six bits of control allow maximum flexibility in torque control for a variety of step methods, from microstepping to full-step drive. Load current is set in 1.56% increments of the maximum value.

Synchronous rectification circuitry allows the load current to flow through the low  $r_{DS(on)}$  of the DMOS output driver during the current decay. This feature will eliminate the need for external clamp diodes in most applications, saving cost and external component count, while minimizing power dissipation.

Internal circuit protection includes thermal shutdown with hysteresis, transient-suppression diodes, and crossover-current protection. Special power-up sequencing is not required.

The A3973SB is supplied in a 24-lead plastic DIP with a copper batwing power tab; the A3973SLB is supplied in a 24-lead plastic SOIC with a copper batwing power tab for surface-mount applications. The power tabs are at ground potential and need no electrical isolation.

### FEATURES

- $\pm 1$  A, 35 V Continuous Output Rating
- Low  $r_{DS(on)}$  DMOS Output Drivers
- Optimized Microstepping via 6-Bit Linear DACs
- Programmable Mixed, Fast, and Slow Current-Decay Modes
- 4 MHz Internal Oscillator for Digital Timing
- Serial-Interface Controls Chip Functions
- Synchronous Rectification for Low Power Dissipation
- Internal UVLO and Thermal Shutdown Circuitry
- Crossover-Current Protection
- Precision 2 V Reference
- Inputs Compatible with 3.3 V or 5 V Control Signals
- Sleep and Idle Modes

### Selection Guide

Part Number	Pb-free*	Package	Packing
A3973SB-T	Yes	24-pin DIP	15 per tube
A3973SLB-T	Yes	24-pin SOIC	31 per tube
A3973SLBTR-T	Yes	24-pin SOIC	1000 per reel

\*Pb-based variants are being phased out of the product line. The variants cited in this footnote are in production but have been determined to be LAST TIME BUY. This classification indicates that sale of this device is currently restricted to existing customer applications. The variants should not be purchased for new design applications because obsolescence in the near future is probable. Samples are no longer available. Status change: October 31, 2006. Deadline for receipt of LAST TIME BUY orders: April 27, 2007. These variants include: A3973SB, A3973SLB, and A3973SLBTR.

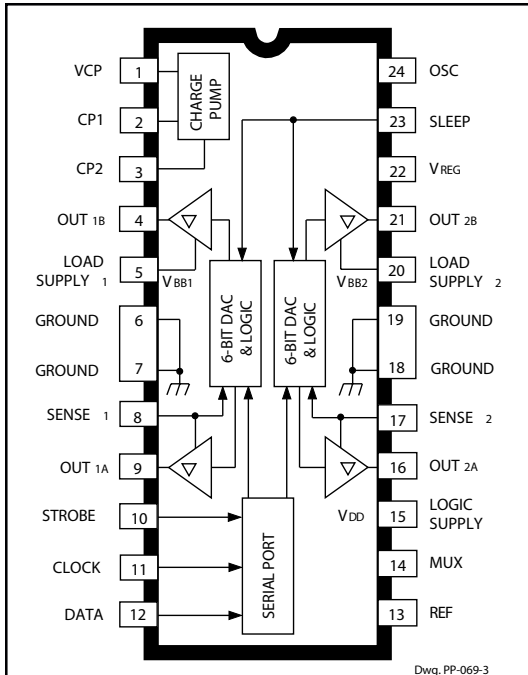

Dwg. PP-069-3

### ABSOLUTE MAXIMUM RATINGS at $T_A = +25^\circ\text{C}$

Load Supply Voltage, $V_{BB}$	35 V
Output Current, $I_{OUT}$	$\pm 1.0$ A
Logic Supply Voltage, $V_{DD}$	7.0 V
Logic Input Voltage Range, $V_{IN}$	-0.3 V to $V_{DD} + 0.3$ V
Reference Voltage, $V_{REF}$	3 V
Sense Voltage (dc), $V_S$	500 mV
Package Power Dissipation, $P_D$	
A3973SB	3.1 W
A3973SLB	2.2 W
Operating Temperature Range, $T_A$	-20°C to +85°C
Junction Temperature, $T_J$	+150°C
Storage Temperature Range, $T_S$	-55°C to +150°C

Output current rating may be limited by duty cycle, ambient temperature, and heat sinking. Under any set of conditions, do not exceed the specified current rating or a junction temperature of 150°C.

# 3973 DUAL DMOS FULL-BRIDGE MICROSTEPPING PWM MOTOR DRIVER

## FUNCTIONAL BLOCK DIAGRAM

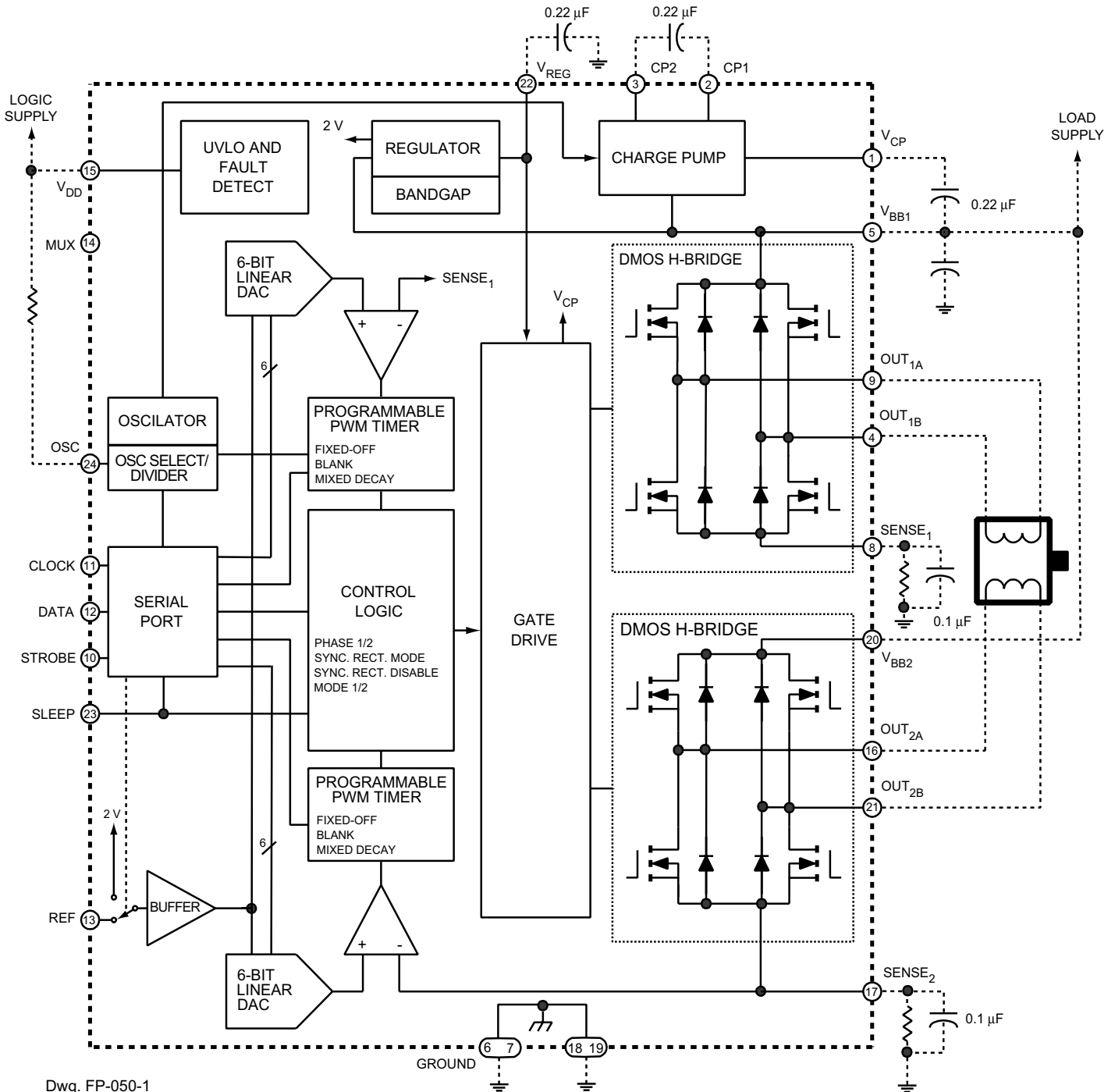

Dwg. FP-050-1

**3973**  
**DUAL DMOS FULL-BRIDGE**  
**MICROSTEPPING PWM MOTOR DRIVER**

**ELECTRICAL CHARACTERISTICS** at  $T_A = +25^\circ\text{C}$ ,  $V_{BB} = 35\text{ V}$ ,  $V_{DD} = 5.0\text{ V}$ ,  $V_S = 0.5\text{ V}$ ,  $f_{\text{PWM}} < 50\text{ kHz}$  (unless otherwise noted).

Characteristic	Symbol	Test Conditions	Limits			
			Min.	Typ.	Max.	Units
Load Supply Voltage Range	$V_{BB}$	Operating	15	—	35	V
		During sleep mode	0	—	35	V
Logic Supply Voltage Range	$V_{DD}$	Operating	4.5	5.0	5.5	V
Load Supply Current	$I_{BB}$	$f_{\text{PWM}} < 50\text{ kHz}$	—	—	8.0	mA
		Operating, outputs disabled	—	—	6.0	mA
		Sleep or idle mode	—	—	20	$\mu\text{A}$
Logic Supply Current	$I_{DD}$	$f_{\text{PWM}} < 50\text{ kHz}$	—	—	12	mA
		Outputs off	—	—	10	mA
		Idle mode (D0 = 1, D18 = 0)	—	—	1.5	mA
		Sleep mode	—	—	100	$\mu\text{A}$
<b>Output Drivers</b>						
Output Leakage Current	$I_{DSS}$	$V_{\text{OUT}} = V_{BB}$	—	<1.0	50	$\mu\text{A}$
		$V_{\text{OUT}} = 0\text{ V}$	—	<-1.0	-50	$\mu\text{A}$
Output On Resistance	$r_{\text{DS(on)}}$	Source driver, $I_{\text{OUT}} = -1.0\text{ A}$	—	0.54	0.60	$\Omega$
		Sink driver, $I_{\text{OUT}} = 1.0\text{ A}$	—	0.54	0.60	$\Omega$
Body Diode Forward Voltage	$V_F$	Source diode, $I_F = 1.0\text{ A}$	—	—	1.2	V
		Sink diode, $I_F = 1.0\text{ A}$	—	—	1.2	V
<b>Control Logic</b>						
Logic Input Voltage	$V_{\text{IN}(1)}$		2.0	—	—	V
	$V_{\text{IN}(0)}$		—	—	0.8	V
Logic Input Current	$I_{\text{IN}(1)}$	$V_{\text{IN}} = 2.0\text{ V}$	—	<1.0	20	$\mu\text{A}$
	$I_{\text{IN}(0)}$	$V_{\text{IN}} = 0.8\text{ V}$	—	<-2.0	-20	$\mu\text{A}$
OSC Input Frequency Range	$f_{\text{OSC}}$	Divide by one (D0 = 1, D13 = 0, D14 = 1)	2.5	—	6.0	MHz
OSC Input Duty Cycle	—		40	—	60	%
Input Hysteresis	$\Delta V_{\text{IN}}$		0.20	—	0.40	V

continued next page ...

**3973****DUAL DMOS FULL-BRIDGE  
MICROSTEPPING PWM MOTOR DRIVER**

**ELECTRICAL CHARACTERISTICS** at  $T_A = +25^\circ\text{C}$ ,  $V_{BB} = 35\text{ V}$ ,  $V_{DD} = 5.0\text{ V}$ ,  $V_S = 0.5\text{ V}$ ,  
 $f_{\text{PWM}} < 50\text{ kHz}$  (unless otherwise noted).

Characteristics	Symbol	Test Conditions	Limits			
			Min.	Typ.	Max.	Units
<b>Control Logic (continued)</b>						
Internal Oscillator	$f_{\text{OSC}}$	OSC shorted to ground	3.0	4.0	5.0	MHz
		$R_{\text{OSC}} = 51\text{ k}\Omega$	3.4	4.0	4.6	MHz
DAC Accuracy (total error)	$E_T$	Relative to DAC reference buffer output, D0 = 0, D17 = 0	—	$\pm 1/2$	—	LSB
Reference Input Voltage Range	$V_{\text{REF(EXT)}}$		0.5	—	2.6	V
Reference Buffer Offset	$V_{\text{OS}}$		—	$\pm 10$	—	mV
Reference Divider Ratio	$V_{\text{REF}}/V_S$	D0 = 0, D18 = 0	—	8.0	—	—
		D0 = 0, D18 = 1	—	4.0	—	—
Reference Input Current	$I_{\text{REF}}$	$V_{\text{REF}} = 2.0\text{ V}$	—	—	$\pm 0.5$	$\mu\text{A}$
Internal Reference Voltage	$V_{\text{REF(INT)}}$		1.94	2.0	2.06	V
Gain ( $G_m$ ) Error (note 3)	$E_G$	D0 = 0, D17 = 0, D18 = 0, DAC = 63	—	0	$\pm 6$	%
		D18 = 0, DAC = 31	—	0	$\pm 9$	%
		D18 = 1, DAC = 63	—	0	$\pm 6$	%
		D18 = 1, DAC = 15	—	0	$\pm 10$	%
Comparator Input Offset Voltage	$V_{\text{IO}}$	$V_{\text{REF}} = 0\text{ V}$	—	$\pm 5.0$	—	mV
Propagation Delay Times	$t_{\text{pd}}$	50% to 90%:				
		PWM change to source on	500	800	1200	ns
		PWM change to source off	50	150	350	ns
		PWM change to sink on	500	800	1200	ns
		PWM change to sink off	50	150	350	ns
Crossover Dead Time	$t_{\text{dt}}$		300	700	900	ns
Thermal Shutdown Temperature	$T_J$		—	165	—	$^\circ\text{C}$
Thermal Shutdown Hysteresis	$\Delta T_J$		—	15	—	$^\circ\text{C}$
UVLO Enable Threshold	$V_{\text{UVLO}}$	Increasing $V_{\text{DD}}$	3.9	4.2	4.45	V
UVLO Hysteresis	$\Delta V_{\text{UVLO}}$		0.05	0.10	—	V

NOTES: 1. Typical Data is for design information only.

2. Negative current is defined as coming out of (sourcing) the specified device terminal.

3.  $E_G = [(V_{\text{REF}}/\text{Range}) - V_S]/(V_{\text{REF}}/\text{Range})$ .

# 3973

## DUAL DMOS FULL-BRIDGE MICROSTEPPING PWM MOTOR DRIVER

### FUNCTIONAL DESCRIPTION

**Serial Interface.** The A3973SB/SLB is controlled via a 3-wire (clock, data, strobe) serial port. The programmable functions allow maximum flexibility in configuring the PWM to the motor drive requirements. The serial data is written as two 19-bit words: 1 bit to select the word and 18 bits of data. The serial data is clocked in starting with D18.

#### Word 0 Bit Assignments

Bit	Function
D0	Word select = 0
D1	Bridge 1, DAC, LSB
D2	Bridge 1, DAC, bit 2
D3	Bridge 1, DAC, bit 3
D4	Bridge 1, DAC, bit 4
D5	Bridge 1, DAC, bit 5
D6	Bridge 1, DAC, MSB
D7	Bridge 2, DAC, LSB
D8	Bridge 2, DAC, bit 2
D9	Bridge 2, DAC, bit 3
D10	Bridge 2, DAC, bit 4
D11	Bridge 2, DAC, bit 5
D12	Bridge 2, DAC, MSB
D13	Bridge 1 phase
D14	Bridge 2 phase
D15	Bridge 1 mode
D16	Bridge 2 mode
D17	REF select
D18	Range select

**D1 – D6 Bridge 1 Linear DAC.** Six-bit word sets desired current level for Bridge 1. Setting all six bits to zero disables Bridge 1, with all drivers off (See current regulation section of functional description).

**D7 – D12 Bridge 2 Linear DAC.** Six-bit word sets desired current level for Bridge 2. Setting all six bits to zero disables Bridge 2, with all drivers off (See current regulation section of functional description).

**D13 Bridge 1 Phase.** This bit controls the direction of output current for Load 1.

D13	OUT <sub>1A</sub>	OUT <sub>1B</sub>
0	L	H
1	H	L

**D14 Bridge 2 Phase.** This bit controls the direction of output current for Load 2.

D14	OUT <sub>2A</sub>	OUT <sub>2B</sub>
0	L	H
1	H	L

**D15 Bridge 1 Mode.**

D15	Mode
0	Mixed-decay
1	Slow-decay

**D16 Bridge 2 Mode.**

D16	Mode
0	Mixed-decay
1	Slow-decay

**D17 REF Select.** This bit determines the reference input for the 6-bit linear DACs.

D17	Reference Voltage
0	Internal 2 V
1	External (3 V max)

**D18 G<sub>m</sub> Range Select.** This bit determines the scaling factor (4 or 8) used.

D18	Divider	Load Current
0	1/8	$I_{TRIP} = V_{DAC}/8R_S$
1	1/4	$I_{TRIP} = V_{DAC}/4R_S$

continued next page ...

## FUNCTIONAL DESCRIPTION (continued)

### Word 1 Bit Assignments

Bit	Function
D0	Word select = 1
D1	Blank-time LSB
D2	Blank-time MSB
D3	Off-time LSB
D4	Off-time bit 1
D5	Off-time bit 2
D6	Off-time bit 3
D7	Off-time MSB
D8	Fast-decay time LSB
D9	Fast-decay time bit 1
D10	Fast-decay time bit 2
D11	Fast-decay time MSB
D12	C0 oscillator control
D13	C1 oscillator control
D14	SR control bit 1
D15	SR control bit 2
D16	Reserved for testing
D17	Reserved for testing
D18	Idle mode

**D1 – D2 Blank Time.** These two bits set the blank time for the current-sense comparator. When a source driver turns on, a current spike occurs due to the reverse-recovery currents of the clamp diodes and/or switching transients related to distributed capacitance in the load. To prevent this current spike from erroneously resetting the source-enable latch, the sense comparator is blanked. The blank timer runs after the off-time counter to provide the programmable blanking function. The blank timer is reset when PHASE is changed.

D2	D1	Time
0	0	$4/f_{OSC}$
0	1	$6/f_{OSC}$
1	0	$8/f_{OSC}$
1	1	$12/f_{OSC}$

**D3 – D7 Fixed Off Time.** These five bits set the fixed off-time for the internal PWM control circuitry. Fixed off-time is defined by:

$$t_{off} = [(1 + N) \times 8/f_{OSC}] - 1/f_{OSC}$$

where  $N = 0 \dots 31$

For example, with a master oscillator frequency of 4 MHz, the fast-decay time will be adjustable from 1.75  $\mu$ s to 63.75  $\mu$ s in increments of 2  $\mu$ s.

**D8 – D11 Fast Decay Time.** These four bits set the fast-decay portion of fixed off-time for the internal PWM control circuitry. The fast-decay portion is defined by:

$$t_{fd} = [(1 + N) \times 8/f_{OSC}] - 1/f_{OSC}$$

where  $N = 0 \dots 15$

For example, with an oscillator frequency of 4 MHz, the fast-decay time will be adjustable from 1.75  $\mu$ s to 31.75  $\mu$ s in increments of 2  $\mu$ s. For  $t_{fd} > t_{off}$ , the device will effectively operate in fast-decay mode.

**D12 – D13 Oscillator Control.** A 4 MHz internal oscillator is used for the timing functions and charge-pump clock. If more precise control is required, an external oscillator can be input to the OSC terminal. To accommodate a wider range of system clocks, an internal divider is provided to generate the desired MO frequency according to the following table:

D13	D12	OSC
0	0	4 MHz internal clock
0	1	External clock
1	0	External clock/2
1	1	External clock/4

**D14 – D15 Synchronous Rectification.**

D15	D14	Synchronous Rectifier
0	0	Active
0	1	Disabled
1	0	Passive
1	1	Low side only

The different modes of operation are in the synchronous rectification section of the functional description.

**D16, D17.** These bits are reserved for testing and should be programmed to zero during normal operation.

**D18 Idle Mode.** The device can be placed in a low power “idle” mode by writing a “0” to D18. The outputs will be disabled, the charge pump will be turned off, and the device will draw a lower load supply current. The undervoltage monitor circuit will remain active. D18 should be programmed high for 1 ms before attempting to enable any output driver.

continued next page ...

## FUNCTIONAL DESCRIPTION (continued)

**V<sub>REG</sub>**: This internally generated supply voltage is used to run the sink-side DMOS outputs. V<sub>REG</sub> is internally monitored and in the case of a fault condition, the outputs of the device are disabled. The V<sub>REG</sub> pin should be decoupled with a 0.22 μF capacitor to ground.

**Current Regulation.** The reference voltage can be set by analog input to the REF terminal, or via the internal 2 V precision reference. The choice of reference voltage and sense resistor set the maximum trip current.

$$I_{TRIPMAX} = V_{REF}/(\text{Range} \times R_S)$$

Microstepping current levels are set according to the following equations:

$$I_{TRIP} = V_{DAC}/(\text{Range} \times R_S)$$

$$V_{DAC} = [(1 + \text{DAC}) \times V_{REF}]/64$$

where DAC input code equals 1 to 63 and Range is 4 or 8 as selected by Word 0, D18. Programming the DAC input code to zero disables the bridge, and results in minimum load current.

**PWM Timer Function.** The PWM timer is programmable via the serial port to provide fixed off-time PWM signals to the control block. In mixed-decay mode, the first portion of the off time operates in fast decay, until the fast-decay time count is reached, followed by slow decay for the rest of the fixed off-time period. If the fast-decay time is set longer than the off-time, the device effectively operates in fast-decay mode.

**Oscillator.** The PWM timer is based on an oscillator input, typically 4 MHz. The A3973SB/SLB can be configured to select either a 4 MHz internal oscillator or, if more precision is required, an external clock can be connected to the OSC terminal. If an external clock is used, three internal divider choices are selectable via the serial port to allow flexibility in choosing f<sub>OSC</sub>, based on available system clocks. If the internal oscillator option is used, the absolute accuracy is dependent on the process variation of resistance and capacitance. A precision resistor can be connected from the OSC terminal to V<sub>DD</sub> to further improve the tolerance. The frequency will be:

$$f_{OSC} = 204 \times 10^9 / R_{OSC}$$

If the internal oscillator is used without the external resistor, the OSC terminal should be connected to ground.

**Sleep Mode.** The input terminal SLEEP is dedicated to putting the device into a minimum current draw mode. When pulled low, the serial port will be reset to all zeros and all circuits will be disabled.

**Shutdown.** In the event of a fault due to excessive junction temperature, or low voltage on V<sub>CP</sub> or V<sub>REG</sub>, the outputs of the device are disabled until the fault condition is removed. At power up, or in the event of low V<sub>DD</sub>, the UVLO circuit disables the drivers and resets the data in the serial port to zeros.

**Synchronous Rectification.** When a PWM off-cycle is triggered, either by a bridge disable command or internal fixed off-time cycle, the load current will recirculate according to the decay mode selected by the control logic. The A3973SB/SLB synchronous rectification feature will turn on the appropriate MOSFET(s) during the current decay and effectively short out the body diodes with the low r<sub>DS(on)</sub> driver. This will lower power dissipation significantly and can eliminate the need for external Schottky diodes for most applications.

Four distinct modes of operation can be configured with the two serial port control bits:

1. **Active Mode.** Prevents reversal of load current by turning off synchronous rectification when a zero current level is detected.
2. **Passive Mode.** Allows reversal of current but will turn off the synchronous rectifier circuit if the load current inversion ramps up to the current limit.
3. **Disabled.** MOSFET switching will not occur during load recirculation. This setting would only be used with four external clamp diodes per bridge.
4. **Low Side Only.** The low-side MOSFETs will switch on during the off time to short out the current path through the MOSFET body diode. With this setting, the high-side MOSFETs will not synchronously rectify so four external diodes from output to supply are recommended. This mode is intended for use with high-power applications where it is desired to save the expense of two external diodes per bridge. In this mode, the sink-side MOSFETs are chopped during the PWM off time. In all other cases, the source-side MOSFETs are chopped in response to a PWM off command.

continued next page ...

# 3973

## DUAL DMOS FULL-BRIDGE MICROSTEPPING PWM MOTOR DRIVER

### APPLICATIONS INFORMATION

**Current Sensing.** To minimize inaccuracies in sensing the  $I_{PEAK}$  current level caused by ground-trace IR drops, the sense resistor should have an independent ground return to the ground terminal of the device. For low-value sense resistors, the IR drops in the sense resistor's PCB traces can be significant and should be taken into account. The use of sockets should be avoided as they can introduce variation in  $R_s$  due to their contact resistance.

**Thermal Protection.** Circuitry turns off all drivers when the junction temperature reaches 165°C typically. It is intended only to protect the device from failures due to excessive junction temperature and should not imply that output short circuits are permitted. Thermal shutdown has a hysteresis of approximately 15°C.

**Serial Port Write Timing Operation.** Data is clocked into a shift register on the rising edge of CLOCK signal. Normally, STROBE will be held high, and only will be brought low to initiate a write cycle. The data is written MSB first, followed by the word-select bit. Refer to serial port diagram for timing requirements.

**Layout.** The printed wiring board should use a heavy ground plane. For optimum electrical and thermal performance, the driver should be soldered directly onto the board. The ground side of  $R_s$  should have an individual path to the ground pin(s) of the driver. This path should be as short as physically possible and should not have any other components connected to it. The load supply pin,  $V_{BB}$ , should be decoupled with an electrolytic capacitor (>47  $\mu$ F is recommended) placed as close to the driver as is possible.

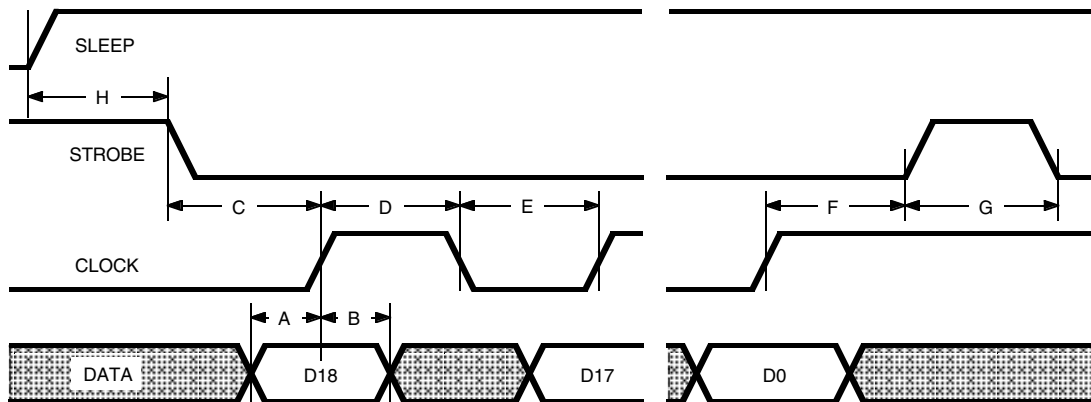

Dwg. WP-038-1

- A. Minimum Data Setup Time ..... 15 ns
- B. Minimum Data Hold Time ..... 10 ns
- C. Minimum Setup Strobe to Clock Rising Edge ..... 150 ns
- D. Minimum Clock High Pulse Width ..... 40 ns
- E. Minimum Clock Low Pulse Width ..... 40 ns
- F. Minimum Setup Clock Rising Edge to Strobe ..... 50 ns
- G. Minimum Strobe Pulse Width ..... 150 ns
- H. Minimum Setup Sleep to Strobe falling ..... 50  $\mu$ s



# 3973 DUAL DMOS FULL-BRIDGE MICROSTEPPING PWM MOTOR DRIVER

## A3973SB Dimensions in Inches (controlling dimensions)

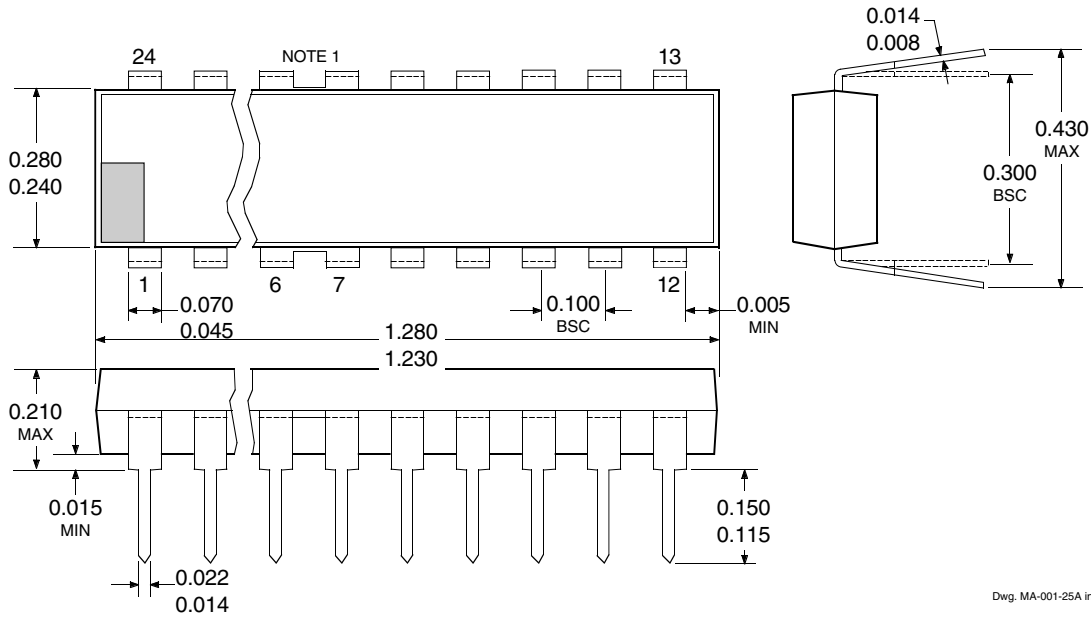

## Dimensions in Millimeters (for reference only)

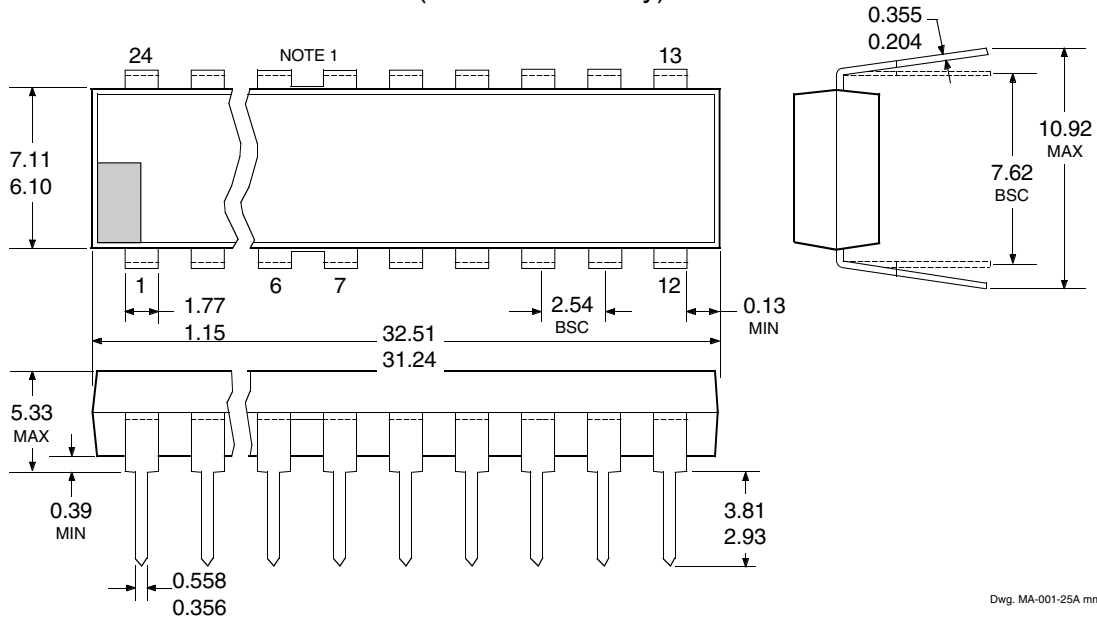

- NOTES: 1. Webbed lead frame. Leads 6, 7, 18, and 19 are internally one piece.  
 2. Lead spacing tolerance is non-cumulative.  
 3. Exact body and lead configuration at vendor's option within limits shown.  
 4. Supplied in standard sticks/tubes of 15 devices.

# 3973 DUAL DMOS FULL-BRIDGE MICROSTEPPING PWM MOTOR DRIVER

## A3973SLB Dimensions in Inches (for reference only)

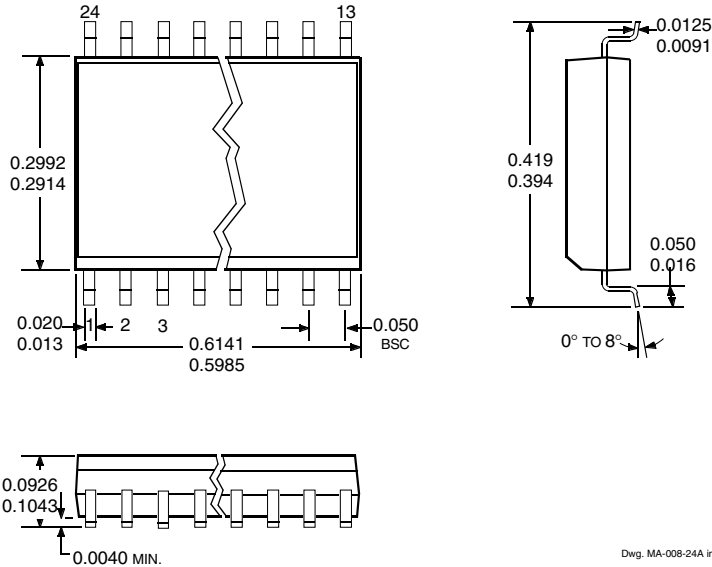

## Dimensions in Millimeters (controlling dimensions)

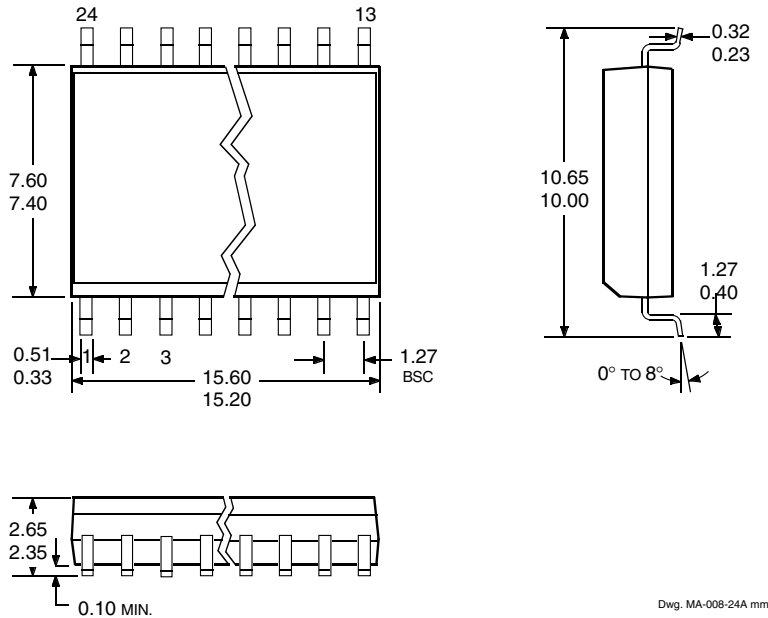

- NOTES: 1. Webbed lead frame. Leads 6, 7, 18, and 19 are internally one piece.  
 2. Lead spacing tolerance is non-cumulative.  
 3. Exact body and lead configuration at vendor's option within limits shown.  
 4. Supplied in standard sticks/tubes of 31 devices or add "TR" to the part number for tape and reel.

**3973**  
**DUAL DMOS FULL-BRIDGE**  
**MICROSTEPPING PWM MOTOR DRIVER**

*The products described here are manufactured under one or more U.S. patents or U.S. patents pending.*

*Allegro MicroSystems, Inc. reserves the right to make, from time to time, such departures from the detail specifications as may be required to permit improvements in the performance, reliability, or manufacturability of its products. Before placing an order, the user is cautioned to verify that the information being relied upon is current.*

*Allegro products are not authorized for use as critical components in life-support devices or systems without express written approval.*

*The information included herein is believed to be accurate and reliable. However, Allegro MicroSystems, Inc. assumes no responsibility for its use; nor for any infringement of patents or other rights of third parties which may result from its use.*

**3973**  
**DUAL DMOS FULL-BRIDGE**  
**MICROSTEPPING PWM MOTOR DRIVER**

**MOTOR DRIVERS**

Function	Output Ratings*		Part Number†
<b>INTEGRATED CIRCUITS FOR BRUSHLESS DC MOTORS</b>			
3-Phase Power MOSFET Controller	—	28 V	3933
3-Phase Power MOSFET Controller	—	50 V	3932
3-Phase Power MOSFET Controller	—	50 V	7600
2-Phase Hall-Effect Sensor/Driver	400 mA	26 V	3626
Bidirectional 3-Phase Back-EMF Controller/Driver	±600 mA	14 V	8906
2-Phase Hall-Effect Sensor/Driver	900 mA	14 V	3625
3-Phase Back-EMF Controller/Driver	±900 mA	14 V	8902–A
3-Phase Controller/Drivers	±2.0 A	45 V	2936 & 2936-120
<b>INTEGRATED BRIDGE DRIVERS FOR DC AND BIPOLAR STEPPER MOTORS</b>			
Dual Full Bridge with Protection & Diagnostics	±500 mA	30 V	3976
PWM Current-Controlled Dual Full Bridge	±650 mA	30 V	3966
PWM Current-Controlled Dual Full Bridge	±650 mA	30 V	3968
PWM Current-Controlled Dual Full Bridge	±750 mA	45 V	2916
PWM Current-Controlled Dual Full Bridge	±750 mA	45 V	2919
PWM Current-Controlled Dual Full Bridge	±750 mA	45 V	6219
PWM Current-Controlled Dual Full Bridge	±800 mA	33 V	3964
PWM Current-Controlled Dual DMOS Full Bridge	±1.0 A	35 V	3973
PWM Current-Controlled Full Bridge	±1.3 A	50 V	3953
PWM Current-Controlled Dual Full Bridge	±1.5 A	45 V	2917
PWM Current-Controlled Microstepping Full Bridge	±1.5 A	50 V	3955
PWM Current-Controlled Microstepping Full Bridge	±1.5 A	50 V	3957
PWM Current-Controlled Dual DMOS Full Bridge	±1.5 A	50 V	3972
Dual Full-Bridge Driver	±2.0 A	50 V	2998
PWM Current-Controlled Full Bridge	±2.0 A	50 V	3952
DMOS Full Bridge PWM Driver	±2.0 A	50 V	3958
Dual DMOS Full Bridge	±2.5 A	50 V	3971
<b>UNIPOLAR STEPPER MOTOR &amp; OTHER DRIVERS</b>			
Voice-Coil Motor Driver	±500 mA	6 V	8932–A
Voice-Coil Motor Driver	±800 mA	16 V	8958
Unipolar Stepper-Motor Quad Drivers	1 A	46 V	7024 & 7029
Unipolar Microstepper-Motor Quad Driver	1.2 A	46 V	7042
Unipolar Stepper-Motor Translator/Driver	1.25 A	50 V	5804
Unipolar Stepper-Motor Quad Driver	1.8 A	50 V	2540
Unipolar Stepper-Motor Quad Driver	1.8 A	50 V	2544
Unipolar Stepper-Motor Quad Driver	3 A	46 V	7026
Unipolar Microstepper-Motor Quad Driver	3 A	46 V	7044

\* Current is maximum specified test condition, voltage is maximum rating. See specification for sustaining voltage limits or over-current protection voltage limits. Negative current is defined as coming out of (sourcing) the output.

† Complete part number includes additional characters to indicate operating temperature range and package style.

Also, see 3175, 3177, 3235, and 3275 Hall-effect sensors for use with brushless dc motors.